

SIEMENS



Products for Totally Integrated Automation





SIMATIC

Catalog
ST 70

Edition
2013

Answers for industry.

Related catalogs

<p>Industrial Communication SIMATIC NET</p> <p>IK PI</p> <p>E86060-K6710-A101-B7-7600</p>	
<p>SIMATIC HMI / PC-based Automation Human Machine Interface Systems PC-based Automation</p> <p>ST 80/ST PC</p> <p>E86060-K4680-A101-B9-7600</p>	
<p>SIMATIC SIMATIC PCS 7 Process Control System</p> <p>ST PCS 7</p> <p>E86060-K4678-A111-B8-7600</p>	
<p>SITOP Power supply SITOP</p> <p>KT 10.1</p> <p>E86060-K2410-A111-A8-7600</p>	
<p>SIMATIC Ident Industrial Identification Systems</p> <p>ID 10</p> <p>E86060-K8310-A101-A8-7600</p>	
<p>SITRAIN Training for Automation and Industrial Solutions</p> <p>ITC</p> <p>Only available in German E86060-K6850-A101-C3</p>	
<p>Products for Automation and Drives Interactive Catalog</p> <p>CA 01</p> <p>DVD: E86060-D4001-A510-D2-7600</p>	
<p>Industry Mall Information and Ordering Platform in the Internet:</p> <p>www.siemens.com/industrymall</p>	

SIMATIC

Products for Totally Integrated Automation

Catalog ST 70 · 2013



Supersedes:
Catalog ST 70 · 2011
Catalog News ST 70 N · 2012

Refer to the Industry Mall for current updates of this catalog:

www.siemens.com/industrymall

The products contained in this catalog can also be found in the Interactive Catalog CA 01.

Order No.:
E86060-D4001-A510-D2-7600

Please contact your local Siemens branch

© Siemens AG 2013

Introduction	1
LOGO! logic module	2
SIMATIC S7-1200	3
SIMATIC S7-1500	4
SIMATIC S7-300	5
SIMATIC S7-400	6
Embedded controller	7
SIMATIC PC-based controller	8
SIMATIC ET 200 distributed I/O	9
SIMATIC control systems	10
Software for SIMATIC controllers	11
SIMATIC programming devices	12
Overviews	13
Supplementary components	14
Appendix	15



Printed on paper from sustainably managed forests and controlled sources.

www.pefc.org

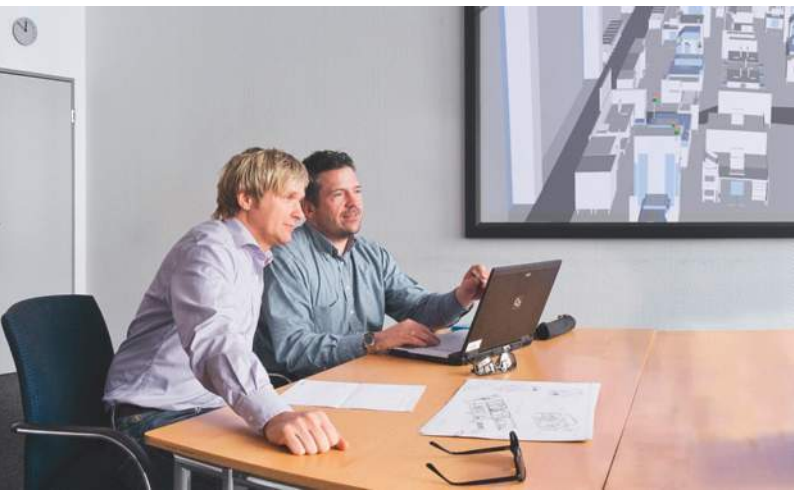



Answers for industry.

Integrated technologies, vertical market expertise and services for greater productivity, energy efficiency, and flexibility.

The Siemens Industry Sector is the world's leading supplier of innovative and environmentally friendly products and solutions for industrial companies. End-to-end automation technology and industrial software, solid market expertise, and technology-based services are the levers we use to increase our customers' productivity, efficiency and flexibility. With a global workforce of more than 100 000 employees, the Industry Sector comprises the Industry Automation, Drive Technologies, and Customer Services divisions, as well as the Metals Technologies Business Unit.

We consistently rely on integrated technologies and, thanks to our bundled portfolio, we can respond more quickly and flexibly to our customers' wishes. With our globally unmatched range of automation technology, industrial control and drive technology as well as industrial software, we equip companies with exactly what they need over their entire value chain – from product design and development to production, sales and service. Our industrial customers benefit from our comprehensive portfolio, which is tailored to their market and their needs.

Market launch times can be reduced by up to 50% due to the combination of powerful automation technology and intelligent industrial software from Siemens Industry. At the same time, the costs for energy or waste water for a manufacturing company can be reduced significantly. In this way, we increase our customers' competitive strength and make an important contribution to environmental protection with our energy-efficient products and solutions.

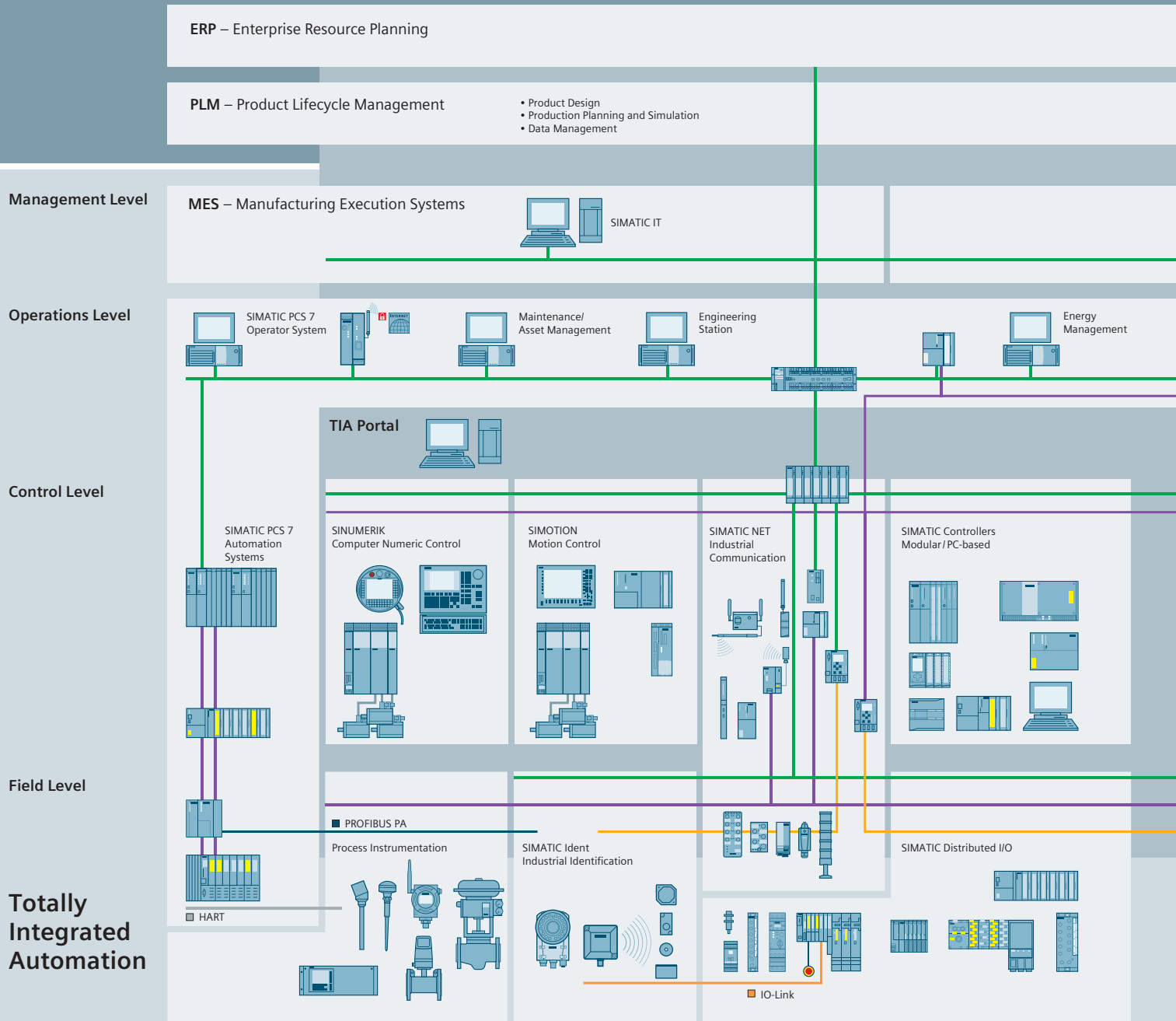

Setting standards in productivity and competitiveness.

Totally Integrated Automation.

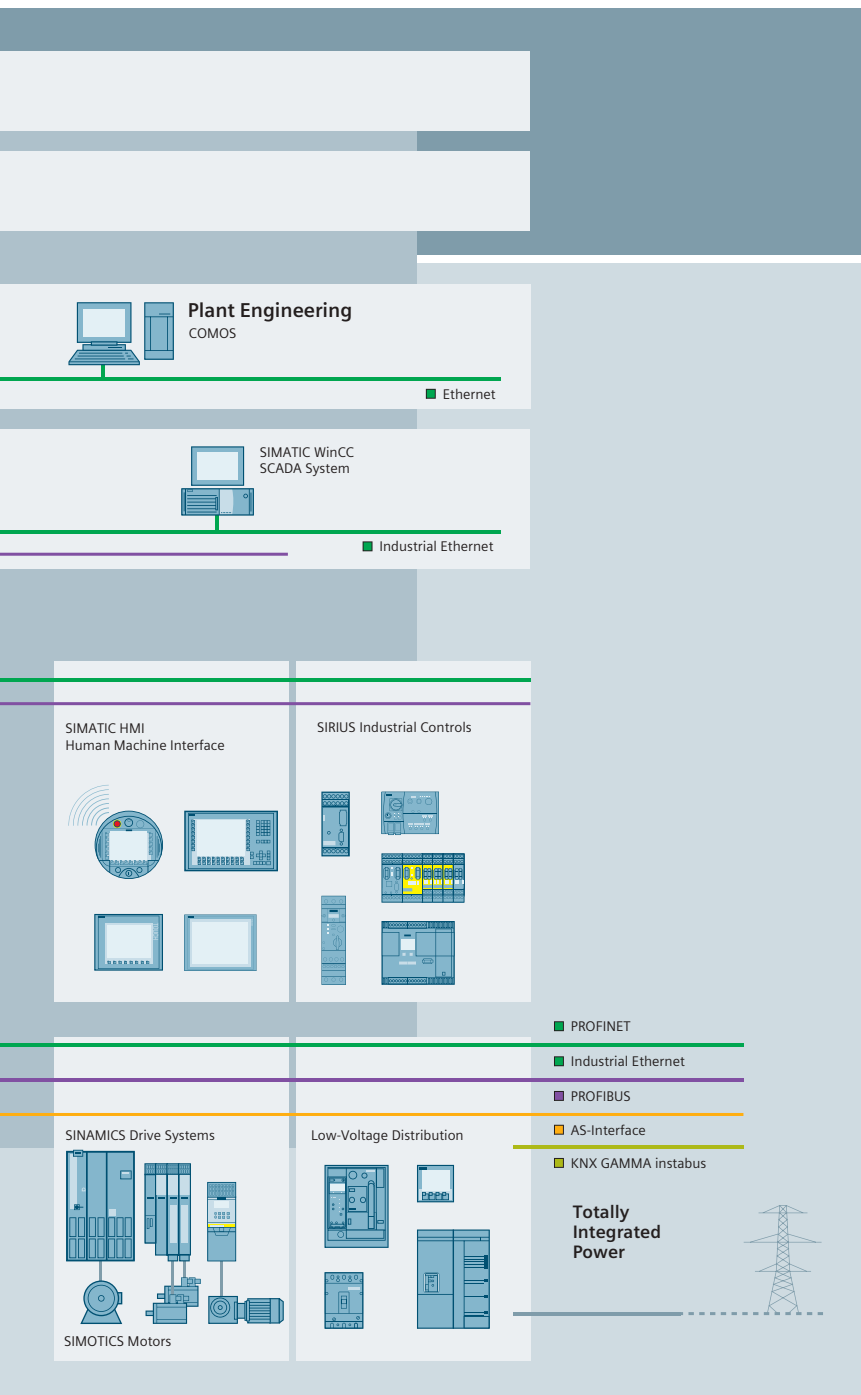

TIA is characterized by its unique continuity.

It provides maximum transparency at all levels with reduced interfacing requirements – covering the field level, production control level, up to the corporate management level. With TIA you also profit throughout the complete life cycle of your plant – starting with the initial planning steps through operation up to modernization, where we offer a high measure of investment security resulting from continuity in the further development of our products and from reducing the number of interfaces to a minimum.

The unique continuity is already a defined characteristic at the development stage of our products and systems.

The result: maximum interoperability – covering the controller, HMI, drives, up to the process control system. This reduces the complexity of the automation solution in your plant. You will experience this, for example, in the engineering phase of the automation solution in the form of reduced time requirements and cost, or during operation using the continuous diagnostics facilities of Totally Integrated Automation for increasing the availability of your plant.

Thanks to Totally Integrated Automation, Siemens provides an integrated basis for the implementation of customized automation solutions – in all industries from inbound to outbound.



**Totally Integrated Power:
Future-proof power supply
from one source.**

Software tools, products, systems and support for integrated electrical power distribution

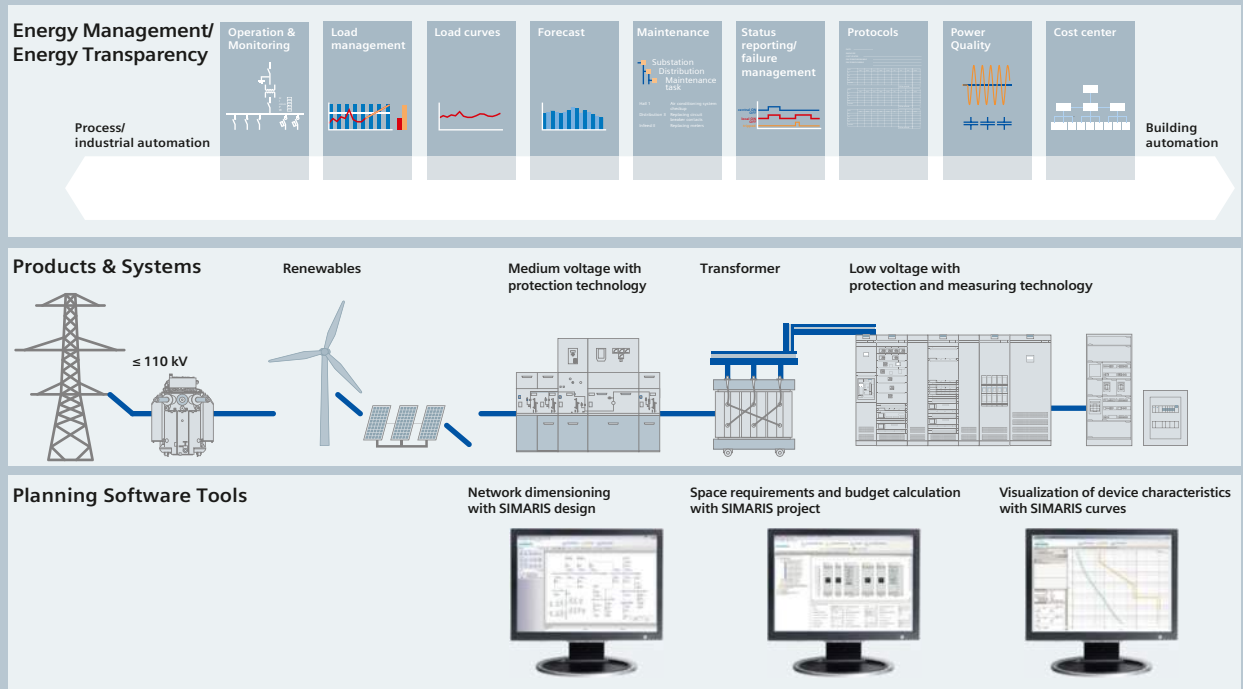

The power supply system acts like a “vital artery”, forming the basis for the reliable and efficient functioning of all electrically operated building installations. Electrical power distribution therefore requires integrated solutions. Our answer: Totally Integrated Power (TIP).

This includes software tools and support for planning and configuration and a complete, optimally aligned product and system portfolio for integrated power distribution from medium-voltage switchgear right to socket outlets.

The power distribution products and systems can be interfaced to building or industrial automation systems (Total Building Solutions or Totally Integrated Automation) via communication-capable circuit breakers and components, allowing the full potential for optimization that an integrated solution offers to be exploited throughout the project cycle – from planning right through to installation and operation.

Get more information:

www.siemens.com/tip
www.siemens.com/simaris
www.siemens.com/specifications

Introduction



1/2	LOGO!
1/3	SIMATIC modular controllers
1/3	SIMATIC S7-1200
1/4	SIMATIC S7-1500
1/5	SIMATIC S7-300
1/7	SIMATIC S7-400
1/9	SIMATIC controllers
1/9	SIMATIC WinAC RTX (F) Embedded Bundles
1/10	SIMATIC programming devices
1/10	SIMATIC Field PG M4
1/11	SIMATIC IPC
1/12	SIMATIC software
1/13	SIMATIC ET 200
1/14	SIMATIC HMI
1/15	SIMATIC PCS 7
1/16	SIMATIC NET

Brochures

For brochures serving as selection guides for SIMATIC products refer to:

www.siemens.com/simatic/printmaterial

Introduction

LOGO!

LOGO! logic module

1

Overview

LOGO!:

Easy-to-use technology with a future

The compact, easy-to-use and low-cost solution for simple control tasks.

Universally applicable in industry, and in functional or residential buildings. Replaces wiring by linking functions.

Operates in a similar way to a programmable logic controller.

With integrated operating and display unit for direct input on the device and display of message texts/variables.

Simple operation:

- Interconnection of functions by mouse click on the PC or at the press of a button on the device

Minimum time requirements:

- Wiring solely of the inputs and outputs
- Parallel creation of circuit diagram and assembly of control cabinet

Reduced costs:

- Many integral functions of switching technology

High level of flexibility:

- Simple modification of functionality at the press of a button
- Versions for different operating voltages
- Modular design, therefore expandable at any time

New in LOGO! 0BA7 versions:

- Networking of max. 9 LOGO! devices
- Use of standard SD cards or SIMATIC memory cards
- Data logging, user-defined functions (macro blocks), astronomical clock
- Ethernet interface for programming and communication with SIMATIC Controllers, SIMATIC Panels and PCs



For further information, refer to:

www.siemens.com/logo

LOGO!	24C 24Co	12/24RC 12/24RCo	24RC 24RCo	12/24 RCE	230RC 230RCo	230 RCE
Supply voltage	24 V DC	12/24 V DC	24 V AC/DC	12/24 V DC	115/230 V AC/DC	115/230 V AC/DC
Inputs	8 (of which 4 for use in analog mode)	8 (of which 4 for use in analog mode)	8	8 (of which 4 for use in analog mode)	8	8
Outputs	4, transistor	4, relay				
Continuous current	0.3 A	10 A (with resistive load), 3 A (with inductive load)				
Short-circuit protection	Electric (1 A)	External fuse required				
Integral time switches/ power reserve	● Power reserve 80 h			● Power reserve 480 h	● Power reserve 80 h	● Power reserve 480 h
Ambient temperature	0 to +55 °C					
Radio interference suppression	In accordance with EN 50 011 (limit class B)					
Degree of protection	IP20					
Certifications	In accordance with VDE 0631, IEC 1131, FM, Class 1, Div 2, cULus, C-Tick, CSA, marine approvals					
Installation	On 35 mm DIN rail or wall mounting					
Dimensions (W x H x D)	72 x 90 x 55 mm (4 modular widths)			108 x 90 x 55 mm (6 modular widths)	72 x 90 x 55 mm (4 modular widths)	108 x 90 x 55 mm (6 modular widths)
Programming cable	LOGO! PC cable (RS232 or USB)			Standard Ethernet	LOGO! PC cable (RS232 or USB)	Standard Ethernet

— = cannot be used/not available

● = can be used/available

Overview**SIMATIC S7-1200:****Modular, compact controller for discrete and stand-alone automation solutions**

- Scalable and flexible design:
The SIMATIC S7-1200 controller family has been designed with maximum flexibility to fit your individual machine requirements. This allows you to custom design your controller systems to meet your needs; it also makes future system expansions quick and easy.
- Integrated Industrial Ethernet/PROFINET interface:
The Industrial Ethernet/PROFINET interface integrated into SIMATIC S7-1200 offers seamless communication with distributed I/O with SIMATIC HMI Panels for visualization and additional controllers for CPU-to-CPU communication. Also with devices from third parties for extended integration possibilities as well as the SIMATIC STEP 7/TIA Portal engineering system for configuring and programming.
- Integrated technology functions:
The proven and innovative technology functions have been integrated into the controller – ranging from counting and measuring, speed, position and duty cycle control to simple process control functionality. This wide variety of functionality enables you to solve a wide array of applications.

Use the innovative S7-1200 in your application as an autonomous mini programmable controller, or apply it to conquer the world of TIA.



For further information, refer to:

www.siemens.com/simatic-s7-1200

SIMATIC S7-1200, CPU	1211C	1212C	1214C	1215C	1217C
Work memory	30 KB	50 KB	75 KB	100 KB	125 KB
Processing times (µs) Bit/word/floating point	0.085/1.7/2.5				
Interfaces					
DP master	● (via CM 1243-5)				
DP slaves	● (via CM 1242-5)				
PtP communication	● (via CM 1241)				
PROFINET	●				
Integrated inputs/outputs					
DI/DO	6/4	8/6	14/10	14/10	14 ¹⁾ /10
AI/AO	2/0	2/0	2/0	2/2	2/2
Integrated functions					
Counters	3 (100 kHz)	4 (3 x 100 kHz, 1 x 30 kHz)	6 (3 x 100 kHz, 3 x 30 kHz)	6 (3 x 100 kHz, 3 x 30 kHz)	6 (2 x 1 kHz, 4 x 100 kHz)
Pulse outputs	4 (100 kHz)	4 (100 kHz)	4 (100 kHz)	4 (100 kHz)	4 (2 x 1 MHz, 2x 100 kHz)
Closed-loop control/ positioning	●	●	●	●	●
Mounting dimensions W x H x D (mm)	90 x 100 x 75	90 x 100 x 75	110 x 100 x 75	130 x 100 x 75	150 x 100 x 75

¹⁾ In addition, the CPU 1217 has a Line Driver IO in order to control stepper motor positioners up to a frequency of 1 MHz.

— = cannot be used/not available

● = can be used/available

Introduction

SIMATIC modular controllers

SIMATIC S7-1500

1

Overview

SIMATIC S7-1500:

Maximum productivity and efficiency

The new SIMATIC S7-1500 controller with its many innovations sets new standards for maximum productivity. This is a benefit both for small series machines and for complex plants with high demands in terms of speed and deterministic response.

The SIMATIC S7-1500 is perfectly integrated into the Totally Integrated Automation Portal (TIA Portal) for maximum engineering efficiency.

- **Scalability:**
The S7-1500 has a modular structure and is scalable in its functionality. Upward compatibility and expandability ensure cost-efficiency and security of investment.
- **Performance:**
The S7-1500 reduces the machine response times, permits greater productivity by means of shorter cycles, and offers an extended scope of programs with a consistent cycle time.
- **User-friendly display operation:**
The display with detailed plain text information that is integrated into the CPU achieves a high level of user-friendliness and full plant transparency.
- **Technology Integrated:**
The S7-1500 enables the integration of motion control without any additional modules. PROFIdrive-capable drives are connected by means of standardized PLCopen blocks.
- **Security Integrated:**
The S7-1500 offers optimized security, even protecting against undesirable access to components and programs. This protects investments and ensures a high level of plant availability.



- **Integrated system diagnostics:**
The S7-1500 offers a diagnostic functionality that is already integrated in the system, without the need for any further programming. A standardized display concept enables error messages to be visualized identically as plain text information in STEP 7 and WinCC, in the web server, and in the display of the CPU.
- **Engineering in the TIA Portal:**
The S7-1500 is seamlessly integrated into the TIA Portal – the innovative engineering framework for all automation tasks.

For further information, refer to:

www.siemens.com/s7-1500

SIMATIC S7-1500, CPU	1511-1 PN	1513-1 PN	1516-3 PN
Display			
Screen diagonals	3.45 cm	3.45 cm	6.1 cm
Memory			
Work memory	150 KB for program 1 MB for data	300 KB for program 1.5 MB for data	1 MB for program 5 MB for data
Instruction times (µs)			
Bit/word/fixed point/floating point	0.06/0.072/0.096/0.384	0.04/0.048/0.064/0.256	0.01/0.012/0.016/0.064
S7 timers/S7 counters	2048/2048		
I/O			
Digital channels	262 144		
Analog channels	16 384		
Interfaces			
PtP communication	● (via CM PtP)	● (via CM PtP)	● (via CM PtP)
PROFIBUS	● (via CM 1542-5)	● (via CM 1542-5)	● (via CM 1542-5); 1 x PB
PROFINET IO	1 x (2-port switch)	1 x (2-port switch)	1 x (2-port switch)
Other	-	-	1 x PROFINET, e.g. for network separation
Web server	●	●	●
Dimensions W x H x D (mm)	35 x 125 x 130 mm	35 x 125 x 130 mm	70 x 125 x 130 mm

— = cannot be used/not available

● = can be used/available

Overview

SIMATIC S7-300:
The modular controller for system solutions in the manufacturing industry

The SIMATIC S7-300 has been designed for innovative system solutions with the focus on manufacturing engineering, and as a universal automation system, it represents an optimal solution for applications in centralized and distributed configurations:

- The ability to integrate powerful CPUs with Industrial Ethernet/PROFINET interface, technological functions or fail-safe designs into one system makes additional investments unnecessary.
- The S7-300 can be set up in a modular configuration without the need for slot rules for I/O modules. There is a wide range of modules available both for the centralized and the distributed configuration with ET200M.
- The Micro Memory Card as a data and program memory does away with the backup battery, and with it, part of the maintenance costs. In addition, an associated project, including symbols and comments, can be stored on this memory card to facilitate service calls.

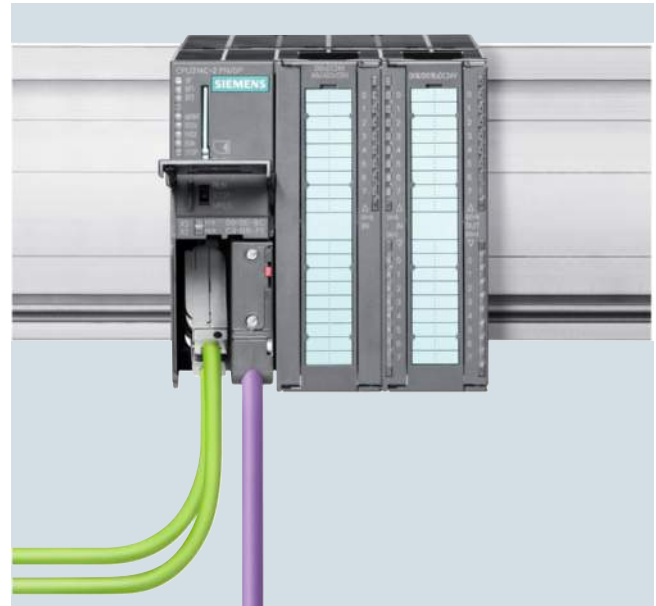

SIMATIC S7-300, CPU	312/314	315-2 DP 315-2 PN/DP	317-2 DP 317-2 PN/DP	319-3 PN/DP	315F-2 DP/ 315F-2 PN/DP	317F-2 DP/ 317F-2 PN/DP	319F-3 PN/DP
Work memory	32/128 ¹⁾ KB	256/384 ²⁾ KB	1024 KB	2 MB	384/512 ³⁾ KB	1.5 MB	2.5 MB
Instructions	10/42 ¹⁾ K	85/128 ²⁾ K	340 K	680 K			
Processing times (µs)							
Bit/word/fixed point/ floating point	0.1/0.06/0.24/ 0.12; 0.32/0.16/1.1/ 0.59 ¹⁾	0.05/0.09/0.12/ 0.45	0.025/0.03/0.04/ 0.16	0.004/0.01/0.01/ 0.04	0.05/0.09/0.12/ 0.45	0.025/0.03/0.04/ 0.16	0.004/0.01/0.01/ 0.04
Timers/counters	256/256	256/256	512/512	2048/2048	256/256	512/512	2048/2048
Address ranges							
Digital channels	256/1024	1024	1024	1024	1024	1024	1024
Analog channels	64/256	256	256	256	256	256	256
Interfaces							
DP master syst. int./ CP 342-5	—/●	●/●	●/●	●/●	●/●	●/●	●/●
DP slaves	—	●	●	●	●	●	●
PtP communication	—	—	—	—	—	—	—
MPI	●	●	●	●	●	●	●
PROFINET IO	—	● ²⁾	●	●	● ³⁾	● ⁴⁾	●
Integrated inputs/outputs							
DI/DO	—	—	—	—	—	—	—
AI/AO	—	—	—	—	—	—	—
Integrated functions							
Counters/frequency meters	—	—	—	—	—	—	—
Pulse outputs	—	—	—	—	—	—	—
Closed-loop control/ positioning	—/—	—/—	—/—	—/—	—	—	—
Mounting dimensions							
W x H x D (mm)	40 x 125 x 130	40 x 125 x 130	40 x 125 x 130	120 x 125 x 130	40 x 125 x 130	40 x 125 x 130	120 x 125 x 130

— = cannot be used/not available
● = can be used/available

¹⁾ CPU 314
²⁾ CPU 315-2 PN/DP

³⁾ CPU 315F-2 PN/DP
⁴⁾ CPU 317F-2 PN/DP

Introduction

SIMATIC modular controllers

SIMATIC S7-300

1

Overview (continued)

- The Micro Memory Card also enables simple program or firmware updates without a programming device. The Micro Memory Card can be used during operation for storing and accessing data, e.g. for measured value archiving or recipe processing.
- In addition to standard automation, safety technology and motion control can also be integrated in an S7-300 controller.
- Many of the S7-300 components are also available in a SIPLUS extreme version for extreme environmental conditions, e.g. extended temperature range (-40/-25 ... +60/+70 °C) and for use where there is corrosive atmosphere/condensation. For more detailed information, visit www.siemens.com/siplus-extreme

For further information, refer to:

www.siemens.com/s7-300



SIMATIC S7-300, CPU	312C/313C	313C-2 PtP/ 313C-2 DP	314C-2 PtP / DP / PN/DP	315T-2 DP	317T-2 DP 317TF-2 DP
Work memory	64/128 ¹⁾ KB	128 KB	192 KB	256 KB	1/1.5 ⁷⁾ MB
Instructions	21/42 ¹⁾ K	42 K	64 K	84 K	340/400 ⁷⁾ K
Processing times (µs)					
Bit/word/fixed point/floating point	0.1/0.24/0.32/1.1; 0.07/0.15/0.2/0.72 ¹⁾	0.07/0.15/0.2/0.72	0.06/0.12/0.16/0.59	0.1/0.2/2/3	0.05/0.2/0.2/1
Timers/counters	256/256	256/256	256/256	256/256	512/512
Address ranges					
Digital channels	266/1016 ¹⁾	1008	1016	512	512
Analog channels	64/253 ¹⁾	248	253	64	64
Interfaces					
DP master syst. int./ CP 342-5	—/●	—/● (●/●) ²⁾	—/● (●/●) ⁵⁾	●/●	●/●
DP slaves	—	● (●) ²⁾	● (●) ⁵⁾	●	●
PtP communication	—	ASCII, RK512, 3964R ³⁾	ASCII, RK512, 3964R ⁴⁾	—	—
MPI	●	●	●	●	●
PROFINET IO	—	—	● ⁶⁾	—	—
Integrated inputs/outputs					
D/DO	10/6 (24/16) ¹⁾	16/16	24/16	4/8	4/8
AI/AO	4/2 ¹⁾	—	4/2	—	—
Integrated functions					
Counters/frequency meters	2 (10 kHz)/ 3 (30 kHz) ¹⁾	3 (30 kHz)	4 (60 kHz)	Technological functions, e.g. gearing/camming, travel to fixed stop, travel/time-dependent cam switching, position- controlled positioning	
Pulse outputs	2 (2.5 kHz)/ 3 (2.5 kHz) ¹⁾	3 (2.5 kHz)	4 (2.5 kHz)		
Closed-loop control/positioning	●/—	●/—	●/●		
Mounting dimensions W x H x D (mm)	80/120 x 125 x 130	80 x 125 x 130	120 x 125 x 130	40/80 x 125 x 130	80/40 x 125 x 130

— = cannot be used/not available
● = can be used/available

1) CPU 313C
2) CPU 313C-2 DP
3) CPU 313C-2 PtP

4) CPU 314C-2 PtP
5) CPU 314C-2 DP
CPU 314C-2 PN/DP

6) CPU 314C-2 PN/DP
7) CPU 317TF-2 DP

Overview

SIMATIC S7-400:**The powerful controller for system solutions in the manufacturing and process industries**

Within the controller family, the SIMATIC S7-400 is designed for system solutions in the manufacturing and process automation industry.

- The S7-400 is especially suitable for data-intensive tasks in the process industry. High processing speeds and deterministic response times guarantee short machine cycle times on high-speed machines in the manufacturing industry. The high-speed backplane bus of S7-400 ensures efficient linking of central I/O modules.
- The S7-400 is used preferably to coordinate overall plants and to control lower-level communications lines with slave stations; this is ensured by the high communication power and the integral interfaces.
- The power of the S7-400 is scalable thanks to a graded range of CPUs; the capacity for I/O is almost unlimited.
- The power reserves of the CPUs enable new functions to be integrated without further hardware investment, e.g. processing of quality data, user-friendly diagnostics, integration into higher-level MES solutions or high-speed communication via bus systems.



SIMATIC S7-400, CPU	412-1/ 412-2	412-2 PN	414-2 / 414-3	414-3 PN/DP	416-2 / 416-3	416-3 PN/DP
Work memory	288/512 ¹⁾ KB	1 MB	1/2.8 ²⁾ MB	4 MB	5.6/11.2 ³⁾ MB	16 MB
Instructions	48/84 ¹⁾ K	170 K	170/460 ²⁾ K	680 K	920/1840 ³⁾ K	2680 K
Processing times (µs)						
Bit/word/fixed point/floating point	75/75/75/225	75/75/75/225	45/45/45/135	45/45/45/135	30/30/30/90	30/30/30/90
Timers/counters	2048/2048	2048/2048	2048/2048	2048/2048	2048/2048	2048/2048
Address range						
Digital channels	32768/32768	32768/32768	65536/65536	65536/65536	131072/131072	131072/131072
Analog channels	2048/2048	2048/2048	4096/4096	4096/4096	8192/8192	8192/8192
DP interfaces						
Number of DP interfaces	1(MPI/DP) / 1 ¹⁾	1(MPI/DP) / 1	1 (2) ²⁾	1	1 (2) ³⁾	1
Number of DP slaves	32/64	32	96 each	125 each	125 each	125 each
Plug-in interface modules	—	—	— / 1 x DP ²⁾	1 x DP	— / 1 x DP ³⁾	1 x DP
PN interfaces						
Number of PN interfaces	—	1 (2 ports)	—	1 (2 ports)	—	1 (2 ports)
PROFINET IO	—	●	—	●	—	●
PROFINET with IRT	—	●	—	●	—	●
PROFINET CBA	—	●	—	●	—	●
TCP/IP	—	●	—	●	—	●
UDP	—	●	—	●	—	●
Web server	—	●	—	●	—	●
ISO-on-TCP (RFC 1006)	—	●	—	●	—	●
Data set gateway	●	●	●	●	●	●
Mounting dimensions						
W x H x D (mm)	25 x 290 x 219	25 x 290 x 219	25/50 x 290 x 219	50 x 290 x 219	25 (50) ³⁾ x 290 x 219	50 x 290 x 219

— = cannot be used/not available
● = can be used/available

¹⁾ CPU 412-2

²⁾ CPU 414-3

³⁾ CPU 416-3

Introduction

SIMATIC modular controllers

SIMATIC S7-400

1

Overview (continued)

- The S7-400 can be structured in a modular way without any slot rules; there is a wide range of modules available both for centralized configurations and distributed structures.
- The configuration of the distributed I/O of the S7-400 can be modified during operation. In addition, signal modules can be removed and inserted while live (hot swapping). This makes it very easy to expand the system or replace modules in the event of a fault.
- Storage of the entire project data, including symbols and comments, on the CPU makes service and maintenance work easier.
- Safety engineering and standard automation can be integrated into a single S7-400 controller; plant availability can be increased through the redundant structure of the S7-400.
- Many S7-400 components are also available in a SIPLUS extreme version for extreme environmental conditions, e.g. for use where there is a corrosive atmosphere/condensation. For more detailed information, visit www.siemens.com/siplus-extreme

For further information, refer to:

www.siemens.com/simatic-s7-400



SIMATIC S7-400, CPU	417-4	412-3H	414-4H	417-4H	414F-3 PN/DP	416F-2	416F-3 PN/DP
Work memory	30 MB	768 KB	2.8 MB	30 MB	4 MB	5.6 MB	16 MB
Instructions	5 M	128 K	460 K	5 M			
Processing times (µs)							
Bit/word/fixed point/floating point	18/18/18/54	75/75/75/225	45/45/45/135	18/18/18/54	45/45/45/135	30/30/30/90	30/30/30/90
Timers/counters	2048/2048	2048/2048	2048/2048	2048/2048	2048/2048	2048/2048	2048/2048
Address ranges							
Digital channels	131072/131072	65536/65536	65536/65536	131072/131072	65536/65536	131072/131072	131072/131072
Analog channels	8192/8192	4096/4096	4096/4096	8192/8192	4096/4096	8192/8192	8192/8192
DP interfaces							
Number of DP interfaces	3	1 (MPI/DP)	2	2	1	1	1
Number of DP slaves	125 each	—	—	—	125 each	125	125 each
Plug-in interface modules	2 x DP	2 x sync	2 x sync	2 x sync	1 x DP	—	1 x DP
PN interfaces							
Number of PN interfaces	—	—	—	—	1 (2 ports)	—	1 (2 ports)
PROFINET IO	—	—	—	—	●	—	●
PROFINET with IRT	—	—	—	—	●	—	●
PROFINET CBA	—	—	—	—	●	—	●
TCP/IP	—	—	—	—	●	—	●
UDP	—	—	—	—	●	—	●
Web server	—	—	—	—	●	—	●
ISO-on-TCP (RFC 1006)	—	—	—	—	●	—	●
Data set gateway	●	—	—	—	●	●	●
Mounting dimensions							
W x H x D (mm)	50 x 290 x 219	50 x 290 x 219	50 x 290 x 219	50 x 290 x 219	50 x 290 x 219	25 x 290 x 219	50 x 290 x 219

— = cannot be used/not available

● = can be used/available

Overview**SIMATIC WinAC RTX (F) / Embedded Bundles**

SIMATIC PC-based Automation uses the real-time-capable software controller WinAC RTX or its fail-safe version WinAC RTX F on the basis of Windows operating systems. Any PC applications, operator control and monitoring tasks, as well as technological functions can simply be combined here to form an overall automation solution.

Thanks to their rugged design and pre-installed, ready-to-use automation software, the SIMATIC Embedded Bundles allow the advantages of PC-based Automation to be used at the machine.

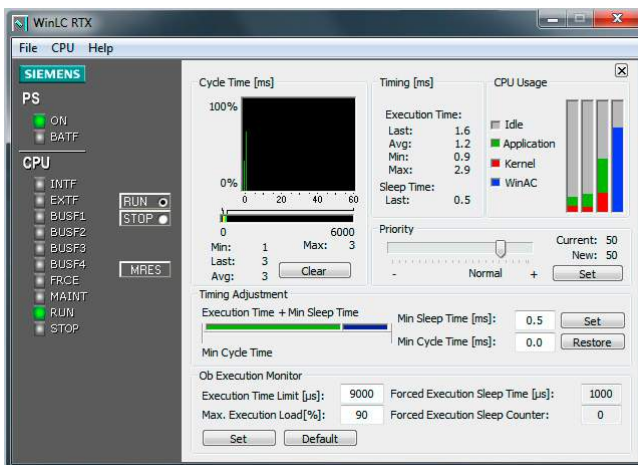
SIMATIC WinAC RTX (F)

SIMATIC WinAC (Windows Automation Center) is the PC-based software controller from Siemens with a real-time response. The WinAC RTX PC-based controller is used when high performance, high data volumes and hard real time are required at the same time. WinAC uses a real-time core for real-time and deterministic behavior. WinAC RTX offers an open data interface to the standard software of the office world on the basis of OPC.

WinAC RTX is programmed using the standard SIMATIC programming tools, and is code-compatible with SIMATIC S7, i.e. program components can be used in SIMATIC S7 and WinAC RTX.

WinAC RTX F provides a TÜV-certified (German Technical Inspectorate), fail-safe software controller for safety-oriented applications. The S7 Distributed Safety software is used for programming the fail-safe program. The PROFIsafe profile permits fail-safe communication via PROFIBUS DP and PROFINET IO.

WinAC RTX is open for integration of technological applications. C/C++/C# programs can also be integrated into the WinAC RTX control program. Extremely flexible solutions can therefore be generated with access to all the hardware and software components of the PC. C/C++/C# is frequently used to program complex technology functions.

C/C++/C# encapsulates these programs. The openness of WinAC RTX can therefore also be used to protect know-how in customized functions.

Embedded Bundles

SIMATIC Embedded Bundles are a ready-to-use combination of hardware and software for control and HMI applications. This results in simple handling and fast commissioning for automation solutions at machine level. Embedded Bundles combine the openness of PC-based controllers with the ruggedness of conventional controllers. In addition, they boast flexible software installed on powerful, scalable hardware in an open, compact combination.

SIMATIC Embedded Bundles are available based on the following hardware:

- SIMATIC IPC227D
- SIMATIC IPC427C
- SIMATIC IPC277D
- SIMATIC HMI IPC477C (PRO)
- SIMATIC S7-mEC Embedded Controller

Thanks to their fan-free and disk-free design, the SIMATIC Embedded Bundles can be used direct at the machine in harsh environments. Windows Embedded Standard is used as the embedded operating system.



For further information, refer to:

www.siemens.com/pc-based-automation

Introduction

SIMATIC programming devices

SIMATIC Field PG M4

1

Overview

SIMATIC Field PG M4: **High-performance industrial notebook with new design**

The latest SIMATIC Field PG M4, a member of the SIMATIC family, offers you a whole range of advantages in addition to wireless technology and Bluetooth at an attractive price/performance ratio:

- Powerful Intel Core processor
- High-resolution 15.6" widescreen display, 16:9 aspect ratio
- Integrated data backup concept
- Powerful battery with intelligent smart phone charging concept and compact power supply unit
- Retractable carry-handle
- Easily replaceable hard disk

All the standard S5 and S7 interfaces required for industrial applications are already onboard the rugged device, which is certified in accordance with the US military standard MIL-STD-810G.

In other words: The ready-to-run SIMATIC Field PG M4 with pre-installed SIMATIC engineering software for controllers and HMI is the ideal industrial notebook – optimized for mobile use in configuring, commissioning, servicing, and maintaining your automation system.

With support from TPM 1.2, the hard disk tool ensures greater security, and iAMT / WoL simplifies the remote administration within the IT infrastructure of your company.

Applications

- Suitable for use in harsh industrial environments due to state-of-the-art material technology.
- Protected against shock and vibration: Rugged magnesium die-cast enclosure with protector strips on exposed parts of the enclosure.
- Safe grip in mobile use: Sturdy, retractable carry-handle.
- Dirt-resistant: Industrial design with dark colors and keyboard with abrasion-resistant laser inscription.
- Protection against electromagnetic interference in harsh industrial environments by means of fully shielded magnesium enclosure (EMC/EMS-tested).
- Lightweight, compact power supply unit.

Interfaces

- 2x fully-featured Ethernet interfaces with high data throughput (10 / 100 / 1000 Mbit) permit a clear separation of office and machine networks.
- Two USB 2.0 and two USB 3.0 interfaces provide ≥ 1 A for a stable power supply for external devices, with a 1.5 A charging function for mobile devices in power-off mode (Apple-compatible).
- Two Industrial WLAN antennas, based on the WLAN standards 802.11 a, b, g and n, permit secure and wireless communication with programmable controllers. The radio link to the terminal equipment is monitored cyclically in the IWLAN and is safe and reliable even in critical situations.
- Bluetooth for the synchronization and transmission of data to Bluetooth-compatible devices such as PDAs or cell phones.
- PROFIBUS DP/MPI interface as well as SIMATIC Memory Card and MultiMedia Card slot.
- S5 interface COM 1 / TTY for SIMATIC S5 PLC connection



Powerful hardware components

- The very latest Intel Core i7 processor offers maximum performance with lowest energy consumption.
- Lithium-ion battery with more than five hours operating time and a discharge time well in excess of five months.
- High-resolution 15.6" widescreen display, 16:9 aspect ratio, with selectable display resolution: protects the eyes and supports ergonomic working up to full HD.
- The integrated Intel HD4000 graphics card, operating via the display port with a resolution of 2560 x 1600 pixels, increases the working screen area by more than 90%.
- High-performance work memory with up to 16 GB DDR3 SDRAM – 1600 MHz: for fast execution and parallel processing of several applications.
- Easily swappable hard drive (250 or 500 GB HDD) or super-fast solid-state drive (300 GB SSD): easily replaceable, depending on environment and required software status.
- Status LED: readable whether display cover is open or closed

Operating system (optionally 2 operating systems)

Microsoft Windows XP Professional SP3 MUI,
Microsoft Windows 7 Ultimate SP 1 (64 bit) MUI

For further information, refer to:

www.siemens.com/simatic-pg

Overview

SIMATIC IPC: the more industrial PC

Professional automation solutions impose a wide range of demands on the industrial PCs used (vibration, cold, dust, heat, steam) year in, year out and round the clock. SIMATIC IPCs are the ideal industry-standard PC platforms for this purpose and they offer:

- high system availability
- high degree of investment protection
- best industrial functionality

SIMATIC IPCs are available in various designs and with different functionalities:

SIMATIC Rack PC

Flexible and powerful industrial PC in 19" design.

SIMATIC Box PC

Compact and rugged industrial PC for universal applicability.

SIMATIC Panel PC











Rugged and high-performance industrial PC with brilliant display.

SIMATIC IPCs can be configured individually and ordered online. Well-matched expansion components, e.g. the SIMATIC IPC DiagMonitor for diagnostics and preventive maintenance, are available for individual expansion of the system availability. SIMATIC IPCs are the ideal platform for PC-based automation and are used in the manufacturing and process industry, as well as in industry-oriented sectors such as transportation systems and traffic engineering, building management, or warehouse systems.



For further information, refer to:

www.siemens.com/simatic-ipc

	Rack PC	Box PC	Panel PC		
8xx series High Industrial Maximum expandability Rugged High performance	 IPC847C	 IPC827C		Identical Mainboard basis	+ Advantages due to identical Mainboard basis + Identical system software and driver due to identical processors and chipsets + Reduced evaluation costs when using different SIMATIC IPCs + Reduced supply of spare parts (e.g. memory, hard disks)
6xx series High Industrial Compact Rugged High performance	 IPC647C	 IPC627C	 HMI IPC677C		
5xx series Industrial High / maximum performance Expandable Cost-effective	 IPC547D		 HMI IPC577C	Identical Mainboard basis	+ Long-term availability and defined further development + Mainboards from our own ¹⁾ development and production facilities + Long-term availability of 4-6 years + 5 year of repair and spare parts service This results in a total service and support period of 9-11 years.
4xx series Embedded Ultra-compact Highly rugged Maintenance-free		 IPC427D	 HMI IPC477D		
2xx series Embedded Nano format Highly rugged Maintenance-free		 IPC227D	 IPC277D	Identical Mainboard basis	¹⁾ The SIMATIC IPC547D is also developed and manufactured in Germany.

Introduction

SIMATIC software

1

Overview

Efficient engineering for all SIMATIC controllers

SIMATIC software is a core component of Totally Integrated Automation and provides the optimum tool for every automation task and every phase of a project. Whether for the manufacturing or process industry, in machine or plant construction, SIMATIC software will allow you to fully utilize the potentials in the engineering workflow.

- Fewer interfaces thanks to integrated engineering environment for logic, HMI, motion control, and process engineering.
- Fast integration of process design into the automation structure as a result of system-wide engineering from a central position.
- Design and implementation times are shortened by structured, process-oriented programming methodology.
- The costs of subsequent projects are reduced because blocks are easy to reuse.
- Efficient process diagnostics increase plant availability.

Standard engineering

- STEP 7, the basic engineering environment for SIMATIC S7-300, S7-400 and WinAC.
- STEP 7 Professional, the comprehensive engineering suite for SIMATIC S7-300, S7-400 and WinAC.
- STEP 7 Micro/WIN, the programming software for SIMATIC S7-200.

Totally Integrated Automation Portal (TIA Portal)

The engineering framework with the name Totally Integrated Automation Portal (TIA Portal) will in future form the basis for all engineering systems for configuring, programming and commissioning programmable controllers. As an integral component of the various engineering systems, the engineering framework will automatically provide a uniform and consistent system response through shared services and features.

SIMATIC STEP 7 V12 is based on the TIA Portal, and offers the standardized operating concept of the new TIA Portal and uses its automatic data consistency and shared services such as configuration, communication and diagnostics. STEP 7 is universally suitable for the current SIMATIC controllers S7-1200, S7-1500, S7-300, S7-400 and WinAC, and offers users a uniform, efficient and intuitive solution.



Engineering systems – based on TIA Portal

- STEP 7 Basic V12, shared engineering for SIMATIC S7-1200 and SIMATIC HMI Basic Panels.
- STEP 7 Professional V12, the easy-to-use, uniform engineering system for all SIMATIC controllers.

Highlights of STEP 7 V12:

- Powerful language innovations: Efficient program editors, integrated symbolic programming
- User-friendly online functionalities: Hardware detection, software upload, module expansion during operation, simulation of S7-1500 (PLCSim), DL in RUN
- Integrated system diagnostics: Uniform display concept for STEP 7, CPU display, Web server and HMI without any configuration overhead, up to 4 real-time traces
- Integrated technology: Technology objects for motion sequences and PID function modules
- Multi-stage security: Integrated protection functions for project and plant protection: Know-how protection, copy protection, 4-stage protection against undesirable access and against manipulation

For further information, refer to:

www.siemens.com/simatic-software

Overview**The right solution for every application**

With SIMATIC ET 200 a wide range of distributed I/O systems is available - for solutions in the control cabinet or without a control cabinet directly at the machine, as well as for applications in hazardous areas. SIMATIC ET 200 systems for cabinet-free configurations are installed in a rugged, fiber-glass reinforced plastic enclosure, making them resistant to shock and dirt, as well as watertight. Furthermore, you need fewer additional components, save on cabling, and profit from extremely fast response times.

The modular design makes it possible to scale and expand the ET 200 systems simply and in small stages. Already integrated additional modules reduce costs and at the same time offer a widely diverse range of possible applications. You can choose from a wide range of possible combinations: digital and analog inputs/outputs, intelligent modules with CPU functionality, safety engineering, motor starters, pneumatic systems, frequency converters, and diverse technology modules.

Communication over PROFINET and PROFIBUS, uniform engineering, transparent diagnostics options as well as optimum interfacing to SIMATIC controllers and HMI devices prove the unique integration of Totally Integrated Automation.

In addition to the fieldbus systems, the point-to-point connection I/O-Link is also available for intelligent connection of sensors and actuators.

For further information, refer to:

www.siemens.com/et200

In a control cabinet (IP20)**ET 200SP**

A new generation of scalable I/O

**ET 200S**

Discretely modular design and multi-functional

**ET 200MP**

The multi-channel and multi-functional IO-device of the S7-1500

**ET 200M**

Modular design with 57-300 modules

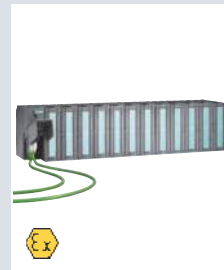
**ET 200iSP**

Intrinsically safe version for hazardous area

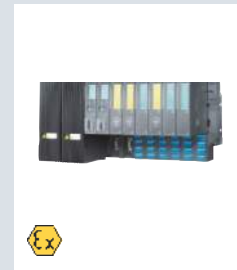
**Without control cabinet (IP65/67)****ET 200pro**

Modular design and multifunctional

**ET 200eco PN**

Low-cost, space-saving block I/O

**ET 200eco**

Low-cost, digital block I/O



Introduction SIMATIC HMI

1

Overview

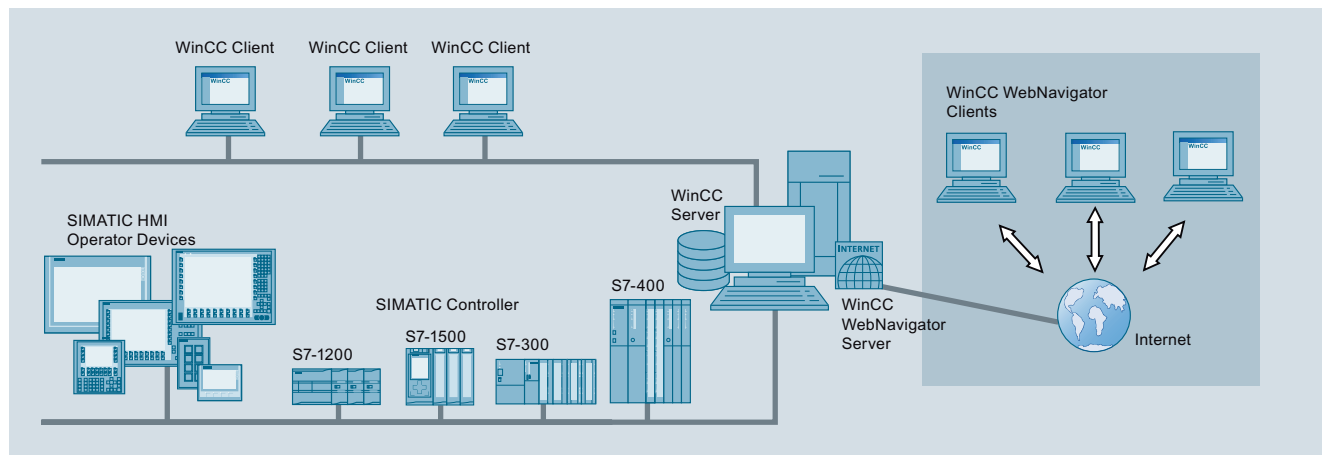

Increase transparency and reduce costs: SIMATIC HMI systems

The interface between human and machine – the human machine interface or HMI for short – connects the world of automation with the individual requirements of the operator. Human machine interfacing is about managing the process, optimizing machine and system operation, availability and productivity.

Everything from a single source

With SIMATIC HMI, Siemens Automation and Drives offers a complete range of innovative and low-cost products and systems for the multi-faceted tasks of operator control and monitoring: Ranging from operator panels and visualization software for operator control and monitoring at the machine through to SCADA systems for widely differing requirements in process visualization. For special requirements, optimally adapted products are offered such as especially rugged operator panels with all-round IP65 protection for mounting on support arms/pedestals, or operator panels with stainless steel fronts for use in the food and beverages industry. Of course, individual, customer-specific requirements can also be implemented.

Perfectly equipped for integration in the world of automation

With their open, standardized interfaces in hardware and software, SIMATIC HMI products can be integrated at any time in the production and automation level as well as in the company management level. Connectability to almost every controller on the market as well as multiple language capability of the configuration and visualization software – including Asian ideographic languages, of course – facilitate operation worldwide.

Flexibility in all HMI applications – from the Basic Panel through the Comfort Panel up to process visualization

SIMATIC WinCC in the Totally Integrated Automation Portal (TIA Portal) is part of a new, integrated engineering framework which offers a uniform engineering environment for programming and configuration of control, visualization and drive solutions.

With WinCC in the TIA Portal it is possible to configure HMI applications ranging from very simple operating solutions with Basic Panels and Comfort Panels up to SCADA applications on PC-based multi-user systems. The possible range of solutions is thus greatly extended compared to the predecessor product SIMATIC WinCC flexible.

Functional or industry-specific expansions of the runtime software are available in the form of options. Some of the options are already integrated as standard functions in the HMI devices of different performance classes, while others can only be executed together with the corresponding Runtime basic software.

The powerful SCADA system SIMATIC WinCC is additionally available for highly complex applications with plant intelligence solutions, integral archive servers or redundant architectures, whereas WinCC Open Architecture is available for applications with high customer-specific adaptation requirements – even for non-Windows platforms.

For further information, refer to:

www.siemens.com/simatic-hmi

Overview

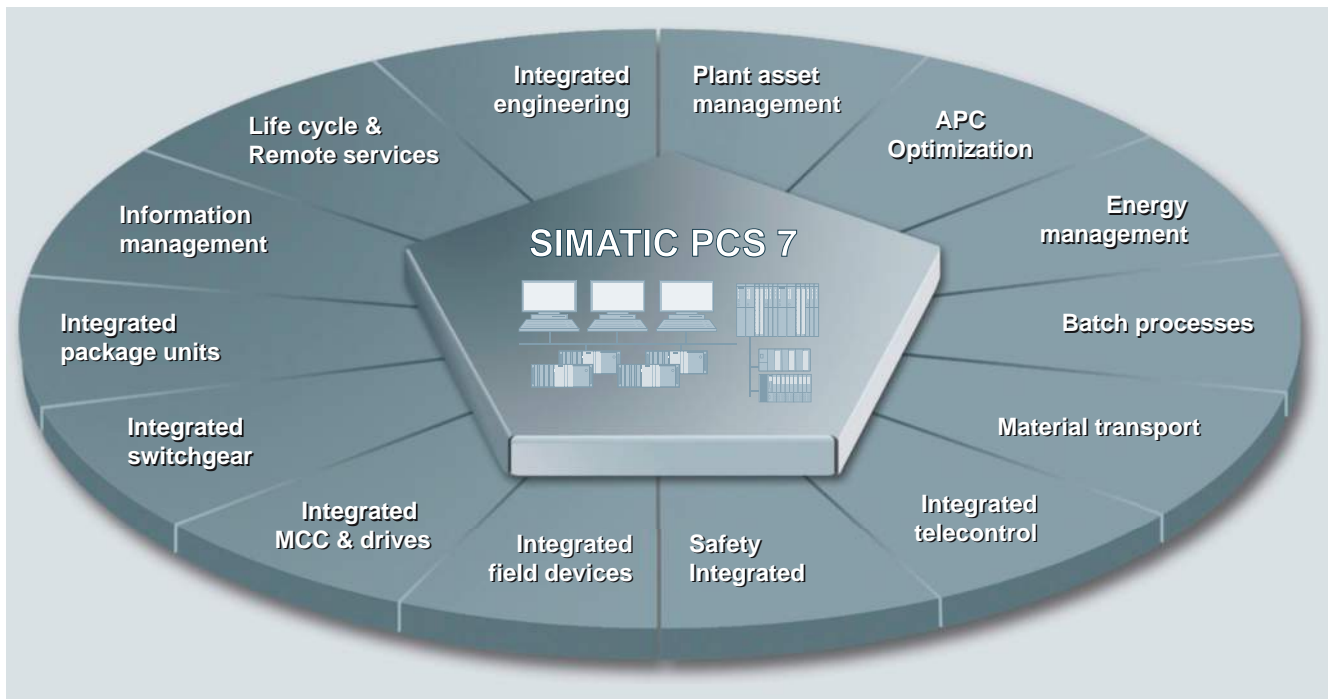
**Progress you trust**

The homogenous and uniform SIMATIC PCS 7 process control system with its unique scalable architecture and outstanding system characteristics is an ideal basis for cost-effective implementation and economic operation of process control plants. Perfect interplay of all components makes it possible for you to sustainably produce in higher quality and to establish new products significantly faster on the market.

Depending on the process-typical automation or individual customer requirements, the basic control system functionality can be expanded with specific system and technology components, e.g. for:

- Diagnostics and maintenance (SIMATIC PCS 7 Maintenance Station)
- Batch process automation (SIMATIC BATCH)
- Route control for material transport (SIMATIC Route Control)
- Functional safety and protection functions (Safety Integrated for Process Automation)
- Industrial security
- Telecontrol of remote units (SIMATIC PCS 7 TeleControl)
- Automation of electrical switchgear (SIMATIC PCS 7 PowerControl)
- Energy management
- Advanced Process Control
- Industrial applications (Industry Library, CEMAT, MINERALS AUTOMATION STANDARD)
- Process Analytical Technology
- IT connection

Additional functionality can be integrated using add-on products. The migration of obsolescent or third-party systems is supported by innovative migration products and solutions.

For further information, refer to:

www.siemens.com/simatic-pcs7

Introduction

SIMATIC NET

1

Overview

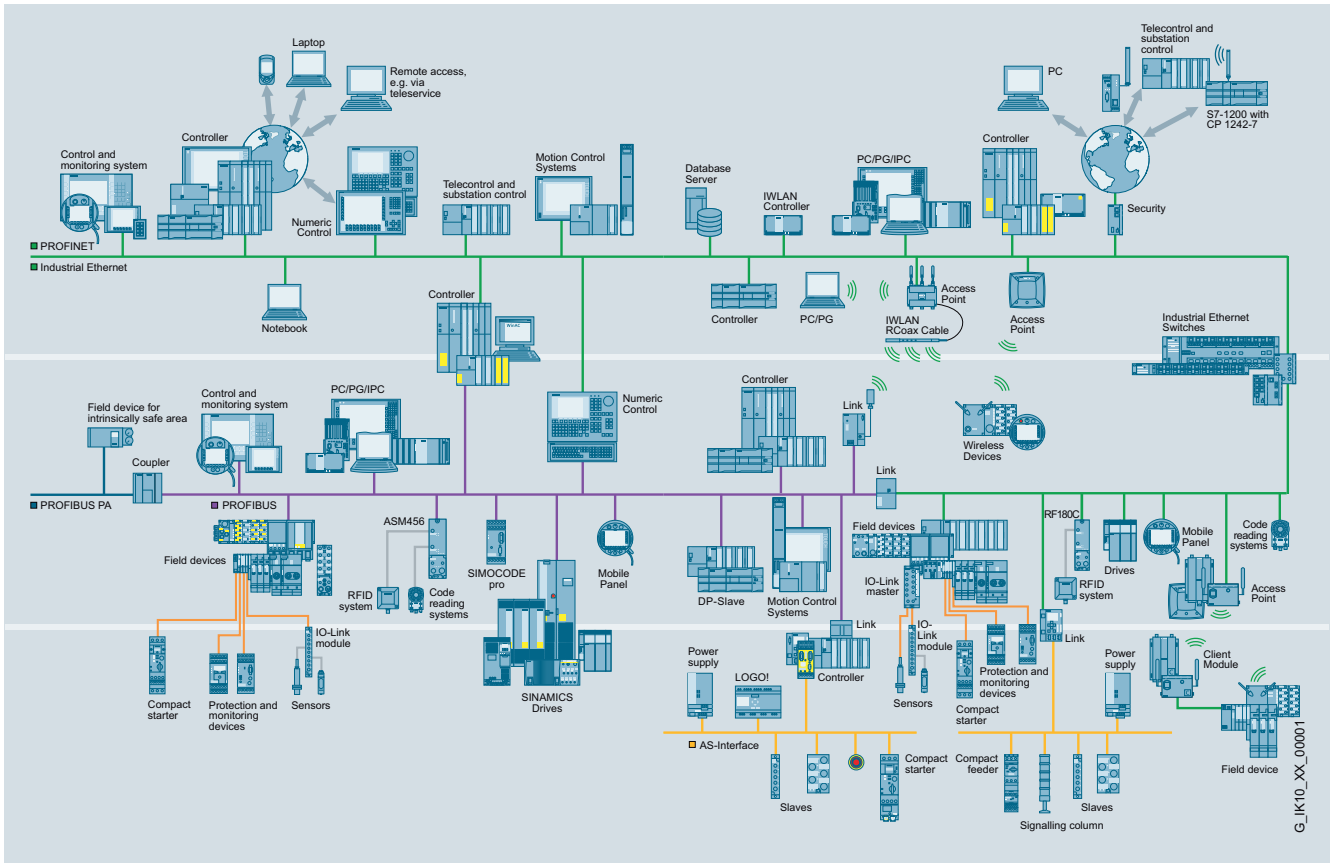

Networking for Industry

Communication networks are of utmost importance for automation solutions. SIMATIC NET – Networking for Industry stands for a diverse range of modular blocks designed for industry to efficiently solve your communications tasks.

SIMATIC NET offers solutions which both maximize the benefits of Ethernet and simply integrate fieldbus systems.

Noticeable examples are:

- The development of the field level for the use of Industrial Ethernet.
- Complete integration from the field level to the corporate management level.
- The promotion of wireless communication.
- The integration of IT technologies.

SIMATIC NET supports the following communications systems:

Industrial Ethernet (in accordance with IEEE 802.3) – the international standard for area networking is currently the number one network in the LAN environment. Powerful communications networks with long ranges can be established via Industrial Ethernet.

The international standard **PROFINET** (IEC 61158/61784) uses Industrial Ethernet and allows real-time communication all the way to the field level, but also integrates the enterprise level. With full utilization of existing IT standards, PROFINET also allows isochronous motion control applications on the Industrial Ethernet, efficient cross-vendor engineering, and high availability of machines and plants on the Industrial Ethernet.

PROFIBUS (IEC 61158/61784) – the international standard for the field level is the global market leader among fieldbus systems. It is the only fieldbus that allows communication in both manufacturing and process applications.

AS-Interface (IEC 62026-2/EN 50295) – as a low-cost alternative to the cable harness, the AS-Interface connects sensors and actuators via twisted-pair cable.

IO-Link – the standard for intelligently connecting sensors and actuators from the field level to the MES level.

Industrial Remote Communication – product portfolio for worldwide access to outlying plants, distant machines, and for mobile applications.

Industrial Wireless Communication – wireless communication over mobile radio (Wireless Remote Networks), with Industrial Wireless LAN (IWLAN in accordance with IEEE 802.11), and for connection of field devices in process automation with the WirelessHART radio standard.

For further information, refer to:

www.siemens.com/simatic-net

LOGO! logic module



2/2	Introduction
2/2	LOGO! logic module
2/3	LOGO! modular
2/3	LOGO! modular basic variants
2/7	SIPLUS LOGO! modular basic variants
2/9	LOGO! modular pure variants
2/12	SIPLUS LOGO! modular pure variants
2/14	LOGO! modular expansion modules
2/19	SIPLUS LOGO! modular expansion modules
2/23	LOGO! CM EIB/KNX communication modules
2/24	LOGO! CSM unmanaged
2/26	AS-Interface connection for LOGO!
2/27	LOGO!Power
2/27	LOGO!Power
2/39	SIPLUS LOGO!Power
2/40	LOGO!Contact
2/41	LOGO! Software

Brochures

For brochures serving as selection guides for SIMATIC products refer to:

www.siemens.com/simatic/printmaterial

LOGO! logic module

Introduction

LOGO! logic module

Overview



LOGO! logic module

- The compact, easy-to-use and low-cost solution for simple control tasks
- Compact, easy to operate, universally applicable without accessories
- "All in one": Integrated display and operator panel
- 36 different functions can be connected at the click of a button or by means of PC software; up to 130 times over
- Functions are easily changed at the press of a key. No more time-consuming rewiring

SIPLUS LOGO!

- The controller for use in the toughest environmental conditions
- With extended temperature range from -40/-25 °C to +70 °C
- Suitable for medial exposure (harmful gas atmosphere)
- Condensation permissible
- With the proven PLC technology of LOGO!
- Easy to handle, program, maintain, and service
- Ideal for use in automotive engineering, environmental engineering, mining, chemical plants, material handling, food industry, etc.

Accessories:

- The front panel mounting set also allows simple and reliable installation of the logic modules in front panels; IP65 protection is thus possible.
- In order to ensure dependable operation of SIPLUS devices supplied by the battery in conjunction with combustion engines, it is necessary to put in a SIPLUS upmiter upstream device between the battery and the SIPLUS LOGO!.

For further information, please go to:

<http://www.siemens.com/siplus-extreme>

For brochures serving as selection guides for SIMATIC products refer to:

<http://www.siemens.com/simatic/printmaterial>

General technical data of the SIPLUS LOGO!

Ambient temperature range	-40/-25 ... +70 °C
Conformal coating	Coating of the printed circuit boards and the electronic components
Technical data	The technical data of the standard product applies except for the ambient conditions.

Ambient conditions

Relative humidity	100%, condensation/frost permissible. No commissioning if condensation present.
Biologically active substances, compliance with EN 60721-3-3	Class 3B2 mold and fungal spores (excluding fauna). The supplied plug covers must remain in place over the unused interfaces during operation!
Chemically active substances, compliance with EN 60721-3-3	Class 3C4 incl. salt spray in accordance with EN60068-2-52 (degree of severity 3). The supplied plug covers must remain in place over the unused interfaces during operation!
Mechanically active substances, compliance with EN 60721-3-3	Class 3S4 incl. sand, dust. The supplied plug covers must remain in place over the unused interfaces during operation!
Air pressure (depending on the highest positive temperature range specified)	1080 ... 795 hPa (-1000 ... +2000 m) see ambient temperature range 795 ... 658 hPa (+2000 ... 3500 m) derating 10 K 658 ... 540 hPa (+3500 ... +5000 m) derating 20 K

Overview



- The space-saving basic variants
- Interface for the connection of expansion modules, up to 24 digital inputs, 16 digital outputs, 8 analog inputs and 2 analog outputs can be addressed
- With connection option for LOGO! text display TD (can be connected to all LOGO! 0BA6 basic variants)

New in LOGO! 0BA7 variants:

- Ethernet interface for communication with SIMATIC Controller, SIMATIC Panel and PC
- Networking of max. 8 LOGO! devices
- Use of standard SD card or SIMATIC memory card

2

Technical specifications

	6ED1 052-1CC01-0BA6	6ED1 052-1MD00-0BA6	6ED1 052-1HB00-0BA6	6ED1 052-1FB00-0BA6
Installation type/mounting				
Mounting	on 35 mm DIN rail, 4 spacing units wide	on 35 mm DIN rail, 4 spacing units wide	on 35 mm DIN rail, 4 spacing units wide	on 35 mm DIN rail, 4 spacing units wide
Supply voltage				
12 V DC		Yes		
24 V DC	Yes	Yes	Yes	
115 V DC				Yes
230 V DC				Yes
permissible range, lower limit (DC)	20.4 V	10.8 V	20.4 V	100 V
permissible range, upper limit (DC)	28.8 V	28.8 V	28.8 V	253 V
24 V AC			Yes	
115 V AC				Yes
230 V AC				Yes
Time of day				
Time switching clocks				
• Power reserve	80 h	80 h	80 h	80 h
Digital inputs				
Number/binary inputs	8; Of which 4 can be used in analog mode (0 to 10 V)	8; Of which 4 can be used in analog mode (0 to 10 V)	8	8
Digital outputs				
Number/binary outputs	4; Transistor	4; Relay	4; Relay	4; Relay
Functionality/short-circuit strength	Yes; electrical (1 A)	No; external fusing necessary	No; external fusing necessary	No; external fusing necessary
Output current				
• for signal "1" permissible range for 0 to 55 °C, max.	0.3 A			
Relay outputs				
• Switching capacity of contacts				
- with inductive load, max.		3 A	3 A	3 A
- Switching frequency/contacts/ at ohmic load/maximum		10 A	10 A	10 A
EMC				
Emission of radio interference acc. to EN 55 011				
• Emission of radio interference acc. to EN 55 011 (limit class B)	Yes; Radio interference suppression according to EN55011, Limit Value Class B	Yes	Yes	Yes
Degree and class of protection				
IP20	Yes	Yes	Yes	Yes

LOGO! logic module

LOGO! modular

LOGO! modular basic variants

Technical specifications (continued)

	6ED1 052-1CC01-0BA6	6ED1 052-1MD00-0BA6	6ED1 052-1HB00-0BA6	6ED1 052-1FB00-0BA6
Standards, approvals, certificates				
CSA approval	Yes	Yes	Yes	Yes
UL approval	Yes	Yes	Yes	Yes
FM approval	Yes	Yes	Yes	Yes
Marine approval	Yes	Yes	Yes	Yes
Developed according to IEC 61131	Yes	Yes	Yes	Yes
according to VDE 0631	Yes	Yes	Yes	Yes
Ambient conditions				
Operating temperature				
• Min.	0 °C	0 °C	0 °C	0 °C
• max.	55 °C	55 °C	55 °C	55 °C
Dimensions				
Width	72 mm	72 mm	72 mm	72 mm
Height	90 mm	90 mm	90 mm	90 mm
Depth	55 mm	55 mm	55 mm	55 mm

	6ED1 052-1MD00-0BA7	6ED1 052-1FB00-0BA7
Installation type/mounting		
Mounting	On 35 mm DIN rail, 6 spacing units wide	On 35 mm DIN rail, 6 spacing units wide
Supply voltage		
12 V DC	Yes	
24 V DC	Yes	
115 V DC		Yes
230 V DC		Yes
permissible range, lower limit (DC)	10.8 V	100 V
permissible range, upper limit (DC)	28.8 V	253 V
115 V AC		Yes
230 V AC		Yes
Time of day		
Time switching clocks		
• Power reserve	480 h	480 h
Digital inputs		
Number/binary inputs	8; Of which 4 can be used in analog mode (0 to 10 V)	8
Digital outputs		
Number/binary outputs	4; Relay	4; Relay
Functionality/short-circuit strength	No; external fusing necessary	No; external fusing necessary
Relay outputs		
• Switching capacity of contacts		
- with inductive load, max.	3 A	3 A
- Switching frequency/contacts/at ohmic load/maximum	10 A	10 A
EMC		
Emission of radio interference acc. to EN 55 011		
• Emission of radio interference acc. to EN 55 011 (limit class B)	Yes; Radio interference suppression according to EN55011, Limit Value Class B	Yes; Radio interference suppression according to EN55011, Limit Value Class B
Degree and class of protection		
IP20	Yes	Yes
Standards, approvals, certificates		
CSA approval	Yes	Yes
UL approval	Yes	Yes
FM approval	Yes	Yes
Marine approval	Yes	Yes
Developed according to IEC 61131	Yes	Yes
according to VDE 0631	Yes	Yes

Technical specifications (continued)

	6ED1 052-1MD00-0BA7	6ED1 052-1FB00-0BA7
Ambient conditions		
Operating temperature		
• Min.	0 °C	0 °C
• max.	55 °C	55 °C
Dimensions		
Width	107 mm	107 mm
Height	90 mm	90 mm
Depth	55 mm	55 mm

Ordering data

Ordering data	Order No.	Ordering data	Order No.
LOGO! logic module 24C 24 V DC power supply, 8x 24 V DC digital inputs, of which 4 can be used in analog mode (0 to 10 V), 4x 24 V DC digital outputs, 0.3 A, integral time switch; 200 function blocks can be inter- linked, modular expansion capability	6ED1 052-1CC01-0BA6	Accessories	
LOGO! logic module 12/24RC 12/24 V DC power supply, 8x 12/24 V DC digital inputs, of which 4 can be used in analog mode (0 to 10 V) 4x 10 A relay outputs, integral time switch; 200 function blocks can be inter- linked, modular expansion capability	6ED1 052-1MD00-0BA6	LOGO! TD text display 4-line text display, can be con- nected to all LOGO! 0BA6 Basic and Pure versions, including con- necting cable	6ED1 055-4MH00-0BA0
LOGO! logic module 24RC 24 V AC/DC power supply, 8x 24 V AC/DC digital inputs, 4x 10 A relay outputs, integral time switch; 200 function blocks can be inter- linked, modular expansion capability	6ED1 052-1HB00-0BA6	SIPLUS LOGO! TD text display (extended temperature range -10 ... +60 °C and medial loading)	6AG1 055-4MH00-2BA0
LOGO! logic module 230RC 115/230 V AC/DC power supply, 8x 115/230 V AC/DC digital inputs, 4x 10 A relay outputs, integral time switch; 200 function blocks can be inter- linked, modular expansion capability	6ED1 052-1FB00-0BA6	4-line text display, can be con- nected to all LOGO! Basic and Pure versions as of -0BA6, including con- necting cable	
LOGO! logic module 230RCE 115/230 V AC/DC power supply, 8x 115/230 V AC/DC digital inputs, 4x 10 A relay outputs, integral time switch; 400 function blocks can be inter- linked, Ethernet interface, modular expansion capability	6ED1 052-1FB00-0BA7	LOGO! Manual German English French Spanish Italian Chinese	6ED1 050-1AA00-0AE8 6ED1 050-1AA00-0BE8 6ED1 050-1AA00-0CE8 6ED1 050-1AA00-0DE8 6ED1 050-1AA00-0EE8 6ED1 050-1AA00-0KE8
LOGO! logic module 12/24RCE 12/24 V DC power supply, 8x 12/24 V DC digital inputs, of which 4 can be used in analog mode (0 to 10 V) 4x 10 A relay outputs, integral time switch; 400 function blocks can be inter- linked, Ethernet interface, modular expansion capability	6ED1 052-1MD00-0BA7	LOGO! Memory Card Program module for copying, with know-how protection	6ED1 056-1DA00-0BA0
LOGO! logic module 230RCE 115/230 V AC/DC power supply, 8x 115/230 V AC/DC digital inputs, 4x 10 A relay outputs, integral time switch; 400 function blocks can be inter- linked, Ethernet interface, modular expansion capability	6ED1 052-1FB00-0BA7	LOGO! battery card Battery module for backing up the integral real-time clock (not LOGO! 24)	6ED1 056-6XA00-0BA0
		LOGO! memory/battery card Combined program and battery module, with know-how protection and for backing up the integral real- time clock (not LOGO! 24)	6ED1 056-7DA00-0BA0
		LOGO! PROM Programming device used to simul- taneously reproduce program mod- ule contents on up to 8 program modules	6AG1 057-1AA01-0BA6
		LOGO!Soft Comfort V7.0 For programming on the PC in LAD/FBD; executes on Windows 7, VISTA, XP, NT4.0, 2000, 98SE, Linux and MAC OSX; on CD-ROM	6ED1 058-0BA02-0YA1
		LOGO!Soft Comfort V7.0 upgrade Upgrade from V1.0 to V7.0	6ED1 058-0CA02-0YE1

LOGO! logic module

LOGO! modular

LOGO! modular basic variants

2

Ordering data	Order No.		Order No.
LOGO! PC cable For program transfer between LOGO! and the PC	6ED1 057-1AA00-0BA0	LOGO! Starter kits (0BA6) In TANOS box, with USB cable, LOGO!, LOGO! Soft Comfort V6	
LOGO! USB PC cable For transferring the program between LOGO! and PC, including driver on CD-ROM	6ED1 057-1AA01-0BA0	LOGO! Starter kit 12/24 V Language-neutral with LOGO! 12/24RC (0BA6)	6ED1 057-3BA00-0AA6
LOGO! modem cable Adapter cable for analog modem communication	6ED1 057-1CA00-0BA0	LOGO! Starter kit 230 V Language-neutral with LOGO! 230RC (0BA6)	6ED1 057-3BA02-0AA6
Front panel mounting set Width 4 MW	6AG1 057-1AA00-0AA0	LOGO! Starter kits (0BA7) In TANOS box, with Ethernet cable, LOGO!, LOGO! Soft Comfort V7, WinCC Basic V11	
Width 4 MW, with keys	6AG1 057-1AA00-0AA3	LOGO! Starter kit 12/24 V Language-neutral with LOGO! 12/24RCE (0BA7) + LOGO! Power 24 V 1.3 A	6ED1 057-3BA00-0AA7
Width 8 MW	6AG1 057-1AA00-0AA1	LOGO! Starter kit 230 V Language-neutral with LOGO! 230RCE (0BA7)	6ED1 057-3BA02-0AA7
Width 8 MW, with keys	6AG1 057-1AA00-0AA2		

Overview



- The space-saving basic variants
- Interface for the connection of expansion modules, up to 24 digital inputs, 16 digital outputs, 8 analog inputs and 2 analog outputs can be addressed
- With connection option for LOGO! text display TD (can be connected to all LOGO! OBA6 basic versions)

New in LOGO! OBA7 variants:

- Ethernet interface for communication with SIMATIC Controller, SIMATIC Panel and PC
- Networking of max. 8 LOGO! devices
- Use of standard SD card or SIMATIC memory card

Note:

SIPLUS extreme products are based on Siemens Industry standard products. The contents listed here were taken from the respective standard products. SIPLUS extreme-specific information was added.

Technical specifications

The technical data correspond to those of the based-on modules apart from the values listed in the table:

Based on	6AG1 052-1CC01-2BA6 6ED1 052-1CC01-0BA6	6AG1 052-1MD00-2BA6 6ED1 052-1MD00-0BA6	6AG1 052-1HB00-2BA6 6ED1 052-1HB00-0BA6	6AG1 052-1FB00-2BA6 6ED1 052-1FB00-0BA6
Ambient conditions				
Operating temperature				
• Min.	-25 °C; = Tmin	-25 °C; = Tmin	-25 °C; = Tmin	-25 °C; = Tmin
• max.	70 °C; = Tmax; 55 °C @ UL/cUL use	70 °C; = Tmax; 55 °C @ UL/cUL use	70 °C; = Tmax; 55 °C @ UL/cUL use	70 °C; = Tmax; 55 °C @ UL/cUL use
Extended ambient conditions				
• Relative to ambient temperature-atmospheric pressure-installation altitude	Tmin ... Tmax at 1080 hPa ... 795 hPa (-1000 m ... +2000 m) // Tmin ... (Tmax - 10K) at 795 hPa ... 658 hPa (+2000 m ... +3500 m) // Tmin ... (Tmax - 20K) at 658 hPa ... 540 hPa (+3500 m ... +5000 m)	Tmin ... Tmax at 1080 hPa ... 795 hPa (-1000 m ... +2000 m) // Tmin ... (Tmax - 10K) at 795 hPa ... 658 hPa (+2000 m ... +3500 m) // Tmin ... (Tmax - 20K) at 658 hPa ... 540 hPa (+3500 m ... +5000 m)	Tmin ... Tmax at 1080 hPa ... 795 hPa (-1000 m ... +2000 m) // Tmin ... (Tmax - 10K) at 795 hPa ... 658 hPa (+2000 m ... +3500 m) // Tmin ... (Tmax - 20K) at 658 hPa ... 540 hPa (+3500 m ... +5000 m)	Tmin ... Tmax at 1080 hPa ... 795 hPa (-1000 m ... +2000 m)
• Relative humidity				
- with condensation	100 %; Relative humidity, incl. condensation / frost permitted (no commissioning under condensation conditions)	100 %; Relative humidity, incl. condensation / frost permitted (no commissioning under condensation conditions)	100 %; Relative humidity, incl. condensation / frost permitted (no commissioning under condensation conditions)	100 %; Relative humidity, incl. condensation / frost permitted (no commissioning under condensation conditions)
• Resistance				
- to biologically active substances	Yes; Class 3B2 mold, fungus and dry rot spores (with the exception of fauna). The supplied connector covers must remain on the unused interfaces during operation!	Yes; Class 3B2 mold, fungus and dry rot spores (with the exception of fauna). The supplied connector covers must remain on the unused interfaces during operation!	Yes; Class 3B2 mold, fungus and dry rot spores (with the exception of fauna). The supplied connector covers must remain on the unused interfaces during operation!	Yes; Class 3B2 mold, fungus and dry rot spores (with the exception of fauna). The supplied connector covers must remain on the unused interfaces during operation!
- to chemically active substances	Yes; Class 3C4 incl. salt spray. The supplied connector covers must remain on the unused interfaces during operation!	Yes; Class 3C4 incl. salt spray. The supplied connector covers must remain on the unused interfaces during operation!	Yes; Class 3C4 incl. salt spray. The supplied connector covers must remain on the unused interfaces during operation!	Yes; Class 3C4 incl. salt spray. The supplied connector covers must remain on the unused interfaces during operation!
- to mechanically active substances	Yes; Class 3S4 incl. sand, dust. The supplied connector covers must remain on the unused interfaces during operation!	Yes; Class 3S4 incl. sand, dust. The supplied connector covers must remain on the unused interfaces during operation!	Yes; Class 3S4 incl. sand, dust. The supplied connector covers must remain on the unused interfaces during operation!	Yes; Class 3S4 incl. sand, dust. The supplied connector covers must remain on the unused interfaces during operation!

LOGO! logic module

LOGO! modular

SIPLUS LOGO! modular basic variants

Technical specifications (continued)

	6AG1 052-1MD00-2BA7	6AG1 052-1FB00-2BA7
Based on	6ED1 052-1MD00-0BA7	6ED1 052-1FB00-0BA7
Ambient conditions		
Operating temperature		
• Min.	-25 °C; = Tmin	-25 °C; = Tmin
• max.	70 °C; = Tmax	70 °C; = Tmax
Extended ambient conditions		
• Relative to ambient temperature-atmospheric pressure-installation altitude	Tmin ... Tmax at 1080 hPa ... 795 hPa (-1000 m ... +2000 m) // Tmin ... (Tmax - 10K) at 795 hPa ... 658 hPa (+2000 m ... +3500 m) // Tmin ... (Tmax - 20K) at 658 hPa ... 540 hPa (+3500 m ... +5000 m)	Tmin ... Tmax at 1080 hPa ... 795 hPa (-1000 m ... +2000 m)
• Relative humidity - with condensation	100 %; Relative humidity, incl. condensation / frost permitted (no commissioning under condensation conditions)	100 %; Relative humidity, incl. condensation / frost permitted (no commissioning under condensation conditions)
• Resistance - to biologically active substances	Yes; Class 3B2 mold, fungus and dry rot spores (with the exception of fauna). The supplied connector covers must remain on the unused interfaces during operation!	Yes; Class 3B2 mold, fungus and dry rot spores (with the exception of fauna). The supplied connector covers must remain on the unused interfaces during operation!
- to chemically active substances	Yes; Class 3C4 incl. salt spray according to EN 60068-2-52 (degree of severity 3). The supplied connector covers must remain on the unused interfaces during operation!	Yes; Class 3C4 incl. salt spray according to EN 60068-2-52 (degree of severity 3). The supplied connector covers must remain on the unused interfaces during operation!
- to mechanically active substances	Yes; Class 3S4 incl. sand, dust. The supplied connector covers must remain on the unused interfaces during operation!	Yes; Class 3S4 incl. sand, dust. The supplied connector covers must remain on the unused interfaces during operation!

Ordering data

	Order No.		Order No.
SIPLUS LOGO! 24 (extended temperature range and medial exposure) 24 V DC supply voltage, 8 digital inputs 24 V DC, of which 4 can be used in analog mode (0 to 10 V), 4 digital outputs 24 V DC, 0.3 A; integrated time switch; 200 function blocks can be inter-linked, modular expansion capability	6AG1 052-1CC01-2BA6	SIPLUS LOGO! 230RC (Extended temperature range and medial exposure) 115/230 V AC/DC supply voltage, 8 digital inputs 115/230 V AC/DC, 4 relay outputs 10 A, integral time switch; 200 function blocks can be inter-linked, modular expansion capability	6AG1 052-1FB00-2BA6
SIPLUS LOGO! 12/24RC (Extended temperature range and medial exposure) 12/24 V DC supply voltage, 8 digital inputs 12/24 V DC, of which 4 can be used in analog mode (0 to 10 V), 4 relay outputs 10 A, integral time switch; 200 function blocks can be inter-linked, modular expansion capability	6AG1 052-1MD00-2BA6	SIPLUS LOGO! 12/24RCE (Extended temperature range and medial exposure) 12/24 V DC supply voltage, 8 digital inputs 12/24 V DC, of which 4 can be used in analog mode (0 to 10 V), 4 relay outputs 10 A, integral time switch; 400 function blocks can be inter-linked, Ethernet interface, modular expansion capability	6AG1 052-1MD00-2BA7
SIPLUS LOGO! 24RC (Extended temperature range and medial exposure) 24 V AC/DC supply voltage, 8 digital inputs 24 V AC/DC, 4 relay outputs 10 A, integral time switch; 200 function blocks can be inter-linked, modular expansion capability	6AG1 052-1HB00-2BA6	SIPLUS LOGO! 230RCE (Extended temperature range and medial exposure) 115/230 V AC/DC supply voltage, 8 digital inputs 115/230 V AC/DC, 4 relay outputs 10 A, integral time switch; 400 function blocks can be inter-linked, Ethernet interface, modular expansion capability	6AG1 052-1FB00-2BA7
		Accessories	
		SIPLUS Upmiter upstream device for reliable operation at the battery of combustion engines	6AG1 053-1AA00-2AA0
		Additional accessories	See LOGO! modular basic variants, page 2/5

Overview



- The cost-optimized basic variants
- Interface for the connection of expansion modules, up to 24 digital inputs, 16 digital outputs, 8 analog inputs and 2 analog outputs can be addressed
- With connection option for LOGO! TD text display (can be connected to all LOGO! 0BA6 basic variants)

2

Technical specifications

	6ED1 052-2CC01-0BA6	6ED1 052-2MD00-0BA6	6ED1 052-2HB00-0BA6	6ED1 052-2FB00-0BA6
Installation type/mounting				
Mounting	on 35 mm DIN rail, 4 spacing units wide	on 35 mm DIN rail, 4 spacing units wide	on 35 mm DIN rail, 4 spacing units wide	on 35 mm DIN rail, 4 spacing units wide
Supply voltage				
12 V DC		Yes		
24 V DC	Yes	Yes	Yes	
115 V DC				Yes
230 V DC				Yes
permissible range, lower limit (DC)	20.4 V	10.8 V	20.4 V	100 V
permissible range, upper limit (DC)	28.8 V	28.8 V	28.8 V	253 V
24 V AC			Yes	
115 V AC				Yes
230 V AC				Yes
Time of day				
Time switching clocks				
• Number	190	8	8	8
• Power reserve	80 h	80 h	80 h	80 h
Digital inputs				
Number/binary inputs	8; Of which 4 can be used in analog mode (0 to 10 V)	8; Of which 4 can be used in analog mode (0 to 10 V)	8	8
Digital outputs				
Number/binary outputs	4; Transistor	4; Relay	4; Relay	4; Relay
Functionality/short-circuit strength	Yes; electrical (1 A)	No; external fusing necessary	No; external fusing necessary	No; external fusing necessary
Output current				
• for signal "1" permissible range for 0 to 55 °C, max.	0.3 A			
Relay outputs				
• Switching capacity of contacts				
- with inductive load, max.		3 A	3 A	3 A
- Switching frequency/contacts/at ohmic load/maximum		10 A	10 A	10 A
EMC				
Emission of radio interference acc. to EN 55 011				
• Emission of radio interference acc. to EN 55 011 (limit class B)	Yes; Radio interference suppression according to EN55011, Limit Value Class B	Yes	Yes	Yes
Degree and class of protection				
IP20	Yes	Yes	Yes	Yes

LOGO! logic module

LOGO! modular

LOGO! modular pure variants

Technical specifications (continued)

	6ED1 052-2CC01-0BA6	6ED1 052-2MD00-0BA6	6ED1 052-2HB00-0BA6	6ED1 052-2FB00-0BA6
Standards, approvals, certificates				
CSA approval	Yes	Yes	Yes	Yes
UL approval	Yes	Yes	Yes	Yes
FM approval	Yes	Yes	Yes	Yes
Marine approval	Yes	Yes	Yes	Yes
Developed according to IEC 61131	Yes	Yes	Yes	Yes
according to VDE 0631	Yes	Yes	Yes	Yes
Ambient conditions				
Operating temperature				
• Min.	0 °C	0 °C	0 °C	0 °C
• max.	55 °C	55 °C	55 °C	55 °C
Dimensions				
Width	72 mm	72 mm	72 mm	72 mm
Height	90 mm	90 mm	90 mm	90 mm
Depth	55 mm	55 mm	55 mm	55 mm

Ordering data

LOGO! logic module 24Co
24 V DC power supply,
8 digital inputs 24 V DC,
of which 4 can be used in analog
mode (0 to 10 V),
4 digital outputs 24 V DC, 0.3 A,
integrated time switch;
without display and keyboard;
200 function blocks can be inter-
linked,
modular expansion capability

Order No.

6ED1 052-2CC01-0BA6

LOGO! logic module 12/24RCo
12/24 V DC power supply,
8 digital inputs 12/24 V DC,
of which 4 can be used in analog
mode (0 to 10 V),
4 relay outputs 10 A,
integral time switch;
without display and keyboard;
200 function blocks can be inter-
linked,
modular expansion capability

6ED1 052-2MD00-0BA6

LOGO! logic module 24RCo
24 V AC/DC power supply,
8 digital inputs 24 V AC/DC,
4 relay outputs 10 A,
integral time switch;
without display and keyboard;
200 function blocks can be inter-
linked,
modular expansion capability

6ED1 052-2HB00-0BA6

LOGO! logic module 230RCo
115/230 V AC/DC power supply,
8 digital inputs 115/230 V AC/DC,
4 relay outputs 10 A,
integral time clock;
without display and keyboard;
200 function blocks can be inter-
linked,
modular expansion capability

6ED1 052-2FB00-0BA6

Order No.

Accessories

LOGO! TD text display

4-line text display, can be
connected to all LOGO! 0BA6 Basic
and Pure versions, including con-
necting cable

6ED1 055-4MH00-0BA0

SIPLUS LOGO! TD text display

(extended temperature range
-10 ... +60 °C and medial loading)

6AG1 055-4MH00-2BA0

4-line text display, can be
connected to all LOGO! 0BA6 Basic
and Pure versions, including con-
necting cable

LOGO! Manual

German
English
French
Spanish
Italian
Chinese

6ED1 050-1AA00-0AE8

6ED1 050-1AA00-0BE8

6ED1 050-1AA00-0CE8

6ED1 050-1AA00-0DE8

6ED1 050-1AA00-0EE8

6ED1 050-1AA00-0KE8

LOGO! Memory Card

Program module for copying,
with know-how protection

6ED1 056-1DA00-0BA0

LOGO! battery card

Battery module for backing
up the integral real-time clock
(not LOGO! 24)

6ED1 056-6XA00-0BA0

Ordering data	Order No.		Order No.
LOGO! memory/battery card Combined program and battery module, with know-how protection and for backing up the integral real-time clock (not LOGO! 240)	6ED1 056-7DA00-0BA0	LOGO! PC cable For program transfer between LOGO! and the PC	6ED1 057-1AA00-0BA0
LOGO! PROM Programming device used to simultaneously reproduce program module contents on up to 8 program modules	6AG1 057-1AA01-0BA6	LOGO! USB PC cable For transferring the program between LOGO! and PC, including driver on CD-ROM	6ED1 057-1AA01-0BA0
LOGO!Soft Comfort V7.0 For programming on the PC in LAD/FBD; executes on Windows 7, VISTA, XP, NT4.0, 2000, 98SE, Linux and MAC OSX; on CD-ROM	6ED1 058-0BA02-0YA1	LOGO! modem cable Adapter cable for analog modem communication	6ED1 057-1CA00-0BA0
LOGO!Soft Comfort V7.0 upgrade Upgrade from V1.0 to V7.0	6ED1 058-0CA02-0YE1	LOGO! Starter kits (0BA6) LOGO! TD Starter kit Language-neutral with LOGO! 12/24RCo + LOGO! TD	6ED1 057-3BA10-0AA6

LOGO! logic module

LOGO! modular

SIPLUS LOGO! modular pure variants

Overview

2



- Basic variants optimized for costs
- Interface for the connection of expansion modules, up to 24 digital inputs, 16 digital outputs, 8 analog inputs and 2 analog outputs can be addressed
- With connection option for LOGO! text display TD (can be connected to all LOGO! 0BA6 basic versions)

Note:

SIPLUS extreme products are based on Siemens Industry standard products. The contents listed here were taken from the respective standard products. SIPLUS extreme-specific information was added.

Technical specifications

The technical data correspond to those of the based-on modules apart from the values listed in the table:

Based on	6AG1 052-2CC01-2BA6 6ED1 052-2CC01-0BA6	6AG1 052-2MD00-2BA6 6ED1 052-2MD00-0BA6	6AG1 052-2HB00-2BA6 6ED1 052-2HB00-0BA6	6AG1 052-2FB00-2BA6 6ED1 052-2FB00-0BA6
Ambient conditions				
Operating temperature				
• Min.	-40 °C; = Tmin	-40 °C; = Tmin	-40 °C; = Tmin	-40 °C; = Tmin
• max.	70 °C; = Tmax; 55 °C @ UL/cUL use	70 °C; = Tmax; 55 °C @ UL/cUL use	70 °C; = Tmax; 55 °C @ UL/cUL use	70 °C; = Tmax; 55 °C @ UL/cUL use
Extended ambient conditions				
• Relative to ambient temperature-atmospheric pressure-installation altitude	Tmin ... Tmax at 1080 hPa ... 795 hPa (-1000 m ... +2000 m) // Tmin ... (Tmax - 10K) at 795 hPa ... 658 hPa (+2000 m ... +3500 m) // Tmin ... (Tmax - 20K) at 658 hPa ... 540 hPa (+3500 m ... +5000 m)	Tmin ... Tmax at 1080 hPa ... 795 hPa (-1000 m ... +2000 m) // Tmin ... (Tmax - 10K) at 795 hPa ... 658 hPa (+2000 m ... +3500 m) // Tmin ... (Tmax - 20K) at 658 hPa ... 540 hPa (+3500 m ... +5000 m)	Tmin ... Tmax at 1080 hPa ... 795 hPa (-1000 m ... +2000 m) // Tmin ... (Tmax - 10K) at 795 hPa ... 658 hPa (+2000 m ... +3500 m) // Tmin ... (Tmax - 20K) at 658 hPa ... 540 hPa (+3500 m ... +5000 m)	Tmin ... Tmax at 1080 hPa ... 795 hPa (-1000 m ... +2000 m)
• Relative humidity				
- with condensation	100 %; Relative humidity, incl. condensation / frost permitted (no commissioning under condensation conditions)	100 %; Relative humidity, incl. condensation / frost permitted (no commissioning under condensation conditions)	100 %; Relative humidity, incl. condensation / frost permitted (no commissioning under condensation conditions)	100 %; Relative humidity, incl. condensation / frost permitted (no commissioning under condensation conditions)
• Resistance				
- to biologically active substances	Yes; Class 3B2 mold, fungus and dry rot spores (with the exception of fauna). The supplied connector covers must remain on the unused interfaces during operation!	Yes; Class 3B2 mold, fungus and dry rot spores (with the exception of fauna). The supplied connector covers must remain on the unused interfaces during operation!	Yes; Class 3B2 mold, fungus and dry rot spores (with the exception of fauna). The supplied connector covers must remain on the unused interfaces during operation!	Yes; Class 3B2 mold, fungus and dry rot spores (with the exception of fauna). The supplied connector covers must remain on the unused interfaces during operation!
- to chemically active substances	Yes; Class 3C4 incl. salt spray. The supplied connector covers must remain on the unused interfaces during operation!	Yes; Class 3C4 incl. salt spray. The supplied connector covers must remain on the unused interfaces during operation!	Yes; Class 3C4 incl. salt spray. The supplied connector covers must remain on the unused interfaces during operation!	Yes; Class 3C4 incl. salt spray. The supplied connector covers must remain on the unused interfaces during operation!
- to mechanically active substances	Yes; Class 3S4 incl. sand, dust. The supplied connector covers must remain on the unused interfaces during operation!	Yes; Class 3S4 incl. sand, dust. The supplied connector covers must remain on the unused interfaces during operation!	Yes; Class 3S4 incl. sand, dust. The supplied connector covers must remain on the unused interfaces during operation!	Yes; Class 3S4 incl. sand, dust. The supplied connector covers must remain on the unused interfaces during operation!

Ordering data	Order No.	Order No.
<p>SIPLUS LOGO! 24o (extended temperature range and medial exposure)</p> <p>24 V DC supply voltage, 8 digital inputs 24 V DC, of which 4 can be used in analog mode (0 to 10 V), 4 digital outputs 24 V DC, 0.3 A, integrated time switch; without display and keyboard; 200 function blocks can be inter-linked, modular expansion capability</p>	<p>6AG1 052-2CC01-2BA6</p>	<p>Accessories</p> <p>SIPLUS Upmiter upstream device for reliable operation at the battery of combustion engines</p> <p>6AG1 053-1AA00-2AA0</p>
<p>SIPLUS LOGO! 12/24RCo (extended temperature range and medial exposure)</p> <p>12/24 V DC supply voltage, 8 digital inputs 12/24 V DC, of which 4 can be used in analog mode (0 to 10 V), 4 relay outputs 10 A, integral time switch; without display and keyboard; 200 function blocks can be inter-linked, modular expansion capability</p>	<p>6AG1 052-2MD00-2BA6</p>	<p>Additional accessories</p> <p>See LOGO! modular pure variants, page 2/10</p>
<p>SIPLUS LOGO! 24RCo (extended temperature range and medial exposure)</p> <p>24 V AC/DC supply voltage, 8 digital inputs 24 V AC/DC, 4 relay outputs 10 A, integral time switch; without display and keyboard; 200 function blocks can be inter-linked, modular expansion capability</p>	<p>6AG1 052-2HB00-2BA6</p>	
<p>SIPLUS LOGO! 230RCo (extended temperature range and medial exposure)</p> <p>115/230 V AC/DC supply voltage, 8 digital inputs 115/230 V AC/DC, 4 relay outputs 10 A, integral time switch; without display and keyboard; 200 function blocks can be inter-linked, modular expansion capability</p>	<p>6AG1 052-2FB00-2BA6</p>	

LOGO! logic module

LOGO! modular

LOGO! modular expansion modules

Overview

2



- Expansion modules for connection to LOGO! modular
- With digital inputs and outputs, analog inputs, or analog outputs

Technical specifications

	6ED1 055-1CB00-0BA0	6ED1 055-1HB00-0BA0	6ED1 055-1MB00-0BA1	6ED1 055-1FB00-0BA1
Installation type/mounting				
Mounting	on 35 mm DIN rail, 2 spacing units wide	on 35 mm DIN rail, 2 spacing units wide	on 35 mm DIN rail, 2 spacing units wide	on 35 mm DIN rail, 2 spacing units wide
Supply voltage				
12 V DC			Yes	
24 V DC	Yes	Yes	Yes	
115 V DC				Yes
230 V DC				Yes
permissible range, lower limit (DC)	20.4 V	20.4 V	10.8 V	100 V
permissible range, upper limit (DC)	28.8 V	28.8 V	28.8 V	253 V
24 V AC		Yes		
115 V AC				Yes
230 V AC				Yes
Digital inputs				
Number/binary inputs	4	4	4	4
Input voltage				
• Type of input voltage	DC	AC/DC	DC	AC/DC
Digital outputs				
Number/binary outputs	4	4; Relay	4; Relay	4; Relay
Functionality/short-circuit strength	Yes; electrical (1 A)	No; external fusing necessary	No; external fusing necessary	No; external fusing necessary
Relay outputs				
• Switching capacity of contacts				
- with inductive load, max.		3 A	3 A	3 A
- Switching frequency/contacts/at ohmic load/maximum		5 A	5 A	5 A
- Thermal continuous current, max.	0.3 A			
EMC				
Emission of radio interference acc. to EN 55 011				
• Emission of radio interference acc. to EN 55 011 (limit class B)	Yes	Yes	Yes	Yes
Degree and class of protection				
IP20	Yes	Yes	Yes	Yes

Technical specifications (continued)

	6ED1 055-1CB00-0BA0	6ED1 055-1HB00-0BA0	6ED1 055-1MB00-0BA1	6ED1 055-1FB00-0BA1
Standards, approvals, certificates				
CSA approval	Yes	Yes	Yes	Yes
UL approval	Yes	Yes	Yes	Yes
FM approval	Yes	Yes	Yes	Yes
Marine approval	Yes	Yes	Yes	Yes
Developed according to IEC 61131	Yes	Yes	Yes	Yes
according to VDE 0631	Yes	Yes	Yes	Yes
Ambient conditions				
Operating temperature				
• Min.	0 °C	0 °C	0 °C	0 °C
• max.	55 °C	55 °C	55 °C	55 °C
Dimensions				
Width	36 mm; 2 DU	36 mm; 2 DU	36 mm; 2 DU	36 mm; 2 DU
Height	90 mm	90 mm	90 mm	90 mm
Depth	55 mm	55 mm	55 mm	55 mm

	6ED1 055-1CB10-0BA0	6ED1 055-1NB10-0BA0	6ED1 055-1FB10-0BA0
Installation type/mounting			
Mounting	on 35 mm DIN rail, 4 spacing units wide	on 35 mm DIN rail, 4 spacing units wide	on DIN rail 25 mm, 4 module spaces wide
Supply voltage			
24 V DC	Yes	Yes	
115 V DC			Yes
230 V DC			Yes
permissible range, lower limit (DC)	20.4 V	20.4 V	100 V
permissible range, upper limit (DC)	28.8 V	28.8 V	253 V
115 V AC			Yes
230 V AC			Yes
Line frequency			
• Frequency of the supply voltage			63 Hz
Digital inputs			
Number/binary inputs	8	8	8
Input voltage			
• Type of input voltage	DC	DC	AC/DC
• for signal "0"	< 5 V DC	< 5 V DC	< 40 V AC; < 30 V DC
• for signal "1"	> 12 V DC	> 12 V DC	> 79 V AC; > 79 V DC
Input current			
• for signal "0", max. (permissible quiescent current)	1 mA	1 mA	0.03 mA
• for signal "1", typ.	2 mA	2 mA	0.08 mA
Input delay (for rated value of input voltage)			
• for standard inputs			
- at "0" to "1", max.	1.5 ms	1.5 ms	50 ms
- at "1" to "0", max.	1.5 ms	1.5 ms	50 ms

LOGO! logic module

LOGO! modular

LOGO! modular expansion modules

Technical specifications (continued)

	6ED1 055-1CB10-0BA0	6ED1 055-1NB10-0BA0	6ED1 055-1FB10-0BA0
Digital outputs			
Number/binary outputs	8	8; Relay	8; Relay
Functionality/short-circuit strength	Yes; electrical (1 A)	No; external fusing necessary	external fusing necessary
Lamp load, max.		1 000 W; 500 W at 115 V AC	1 000 W; 500 W at 115 V AC
Controlling a digital input	Yes	Yes	Yes
Parallel switching of 2 outputs • for increased power	No	No	No
Switching frequency • with resistive load, max. • with inductive load, max. • mechanical, max.	10 Hz 0.5 Hz	2 Hz 0.5 Hz 10 Hz	2 Hz 0.5 Hz 10 Hz
Relay outputs • Switching capacity of contacts - with inductive load, max. - Switching frequency/contacts/at ohmic load/maximum - Thermal continuous current, max.	0.3 A	3 A 5 A	3 A 5 A
EMC			
Emission of radio interference acc. to EN 55 011 • Emission of radio interference acc. to EN 55 011 (limit class B)	Yes	Yes	Yes
Degree and class of protection			
IP20	Yes	Yes	Yes
Standards, approvals, certificates			
CSA approval	Yes	Yes	Yes
UL approval	Yes	Yes	Yes
FM approval	Yes	Yes	Yes
Marine approval	Yes	Yes	Yes
Developed according to IEC 61131	Yes	Yes	Yes
according to VDE 0631	Yes	Yes	Yes
Ambient conditions			
Operating temperature • Min. • max.	0 °C 55 °C	0 °C 55 °C	0 °C 55 °C
Dimensions			
Width	72 mm; 4 WU	72 mm; 4 WU	72 mm; 4 WU
Height	90 mm	90 mm	90 mm
Depth	53 mm	53 mm	53 mm

	6ED1 055-1MA00-0BA0	6ED1 055-1MD00-0BA1
Installation type/mounting		
Mounting	on 35 mm DIN rail, 2 spacing units wide	
Supply voltage		
12 V DC	Yes	Yes; 10.8 to 28.8 V DC
24 V DC	Yes	Yes; 10.8 to 28.8 V DC
Analog inputs		
Number of analog inputs	2	2; 2 or 3 wire connection
Input ranges • Voltage • Current • Resistance thermometer	Yes Yes	Yes; For PT100/PT1000 sensors
Input ranges (rated values), voltages • 0 to +10 V	Yes	
Input ranges (rated values), currents • 0 to 20 mA	Yes	

Technical specifications (continued)

	6ED1 055-1MA00-0BA0	6ED1 055-1MD00-0BA1
EMC		
Emission of radio interference acc. to EN 55 011		
• Emission of radio interference acc. to EN 55 011 (limit class B)	Yes	Yes; Radio interference suppression according to EN55011, Limit Value Class B
Degree and class of protection		
IP20	Yes	Yes
Standards, approvals, certificates		
CSA approval	Yes	Yes; C22.2 Number 142
UL approval	Yes	Yes; UL 508
FM approval	Yes	Yes; FM-Standards No. 3611, 3600, 3810 Class I, Division 2, Group A, B, C, D
Marine approval	Yes	Yes; ABS, BV, DNV, GL, LRS, Class NK
Developed according to IEC 61131	Yes	Yes; EN 61131-2 (IEC 1131-2)
according to VDE 0631	Yes	
Ambient conditions		
Operating temperature		
• Min.	0 °C	0 °C
• max.	55 °C	55 °C
Dimensions		
Width	36 mm	36 mm
Height	90 mm	90 mm
Depth	55 mm	53 mm

	6ED1 055-1MM00-0BA1
Installation type/mounting	
Mounting	on 35 mm DIN rail, 2 spacing units wide
Supply voltage	
12 V DC	No
24 V DC	Yes
Analog outputs	
Number of analog outputs	2
Output ranges, voltage	
• 0 to 10 V	Yes
EMC	
Emission of radio interference acc. to EN 55 011	
• Emission of radio interference acc. to EN 55 011 (limit class B)	Yes; Radio interference suppression according to EN55011, Limit Value Class B
Degree and class of protection	
IP20	Yes

	6ED1 055-1MM00-0BA1
Standards, approvals, certificates	
CSA approval	Yes
UL approval	Yes
FM approval	Yes
Marine approval	Yes
Developed according to IEC 61131	Yes
according to VDE 0631	Yes
Ambient conditions	
Operating temperature	
• Min.	0 °C
• max.	55 °C
Dimensions	
Width	36 mm
Height	90 mm
Depth	55 mm

LOGO! logic module

LOGO! modular

LOGO! modular expansion modules

2

Ordering data	Order No.	Order No.
LOGO! DM8 24 Supply voltage 24 V DC, 4 digital inputs 24 V DC, 4 digital outputs 24 V DC, 0.3 A	6ED1 055-1CB00-0BA0	
LOGO! DM16 24 Supply voltage 24 V DC, 8 digital inputs 24 V DC, 8 digital outputs 24 V DC, 0.3 A	6ED1 055-1CB10-0BA0	
LOGO! DM8 12/24R Supply voltage 12/24 V DC, 4 digital inputs 12/24 V DC, 4 relay outputs 5 A	6ED1 055-1MB00-0BA1	
LOGO! DM8 24R Supply voltage 24 V AC/DC, 4 digital inputs 24 V AC/DC, 4 relay outputs 5 A	6ED1 055-1HB00-0BA0	
LOGO! DM16 24R Supply voltage 24 V DC, 8 digital inputs 24 V DC, 8 relay outputs 5 A	6ED1 055-1NB10-0BA0	
LOGO! DM8 230R Supply voltage 115/230 V AC/DC, 4 digital inputs 115/230 V AC/DC, 4 relay outputs 5 A	6ED1 055-1FB00-0BA1	
LOGO! DM16 230R Supply voltage 115/230 V AC/DC, 8 digital inputs 115/230 V AC/DC, 8 relay outputs 5 A	6ED1 055-1FB10-0BA0	
LOGO! AM2 Supply voltage 12/24 V DC, 2 analog inputs 0 ... 10 V or 0 ... 20 mA, 10-bit resolution	6ED1 055-1MA00-0BA0	
LOGO! AM2 PT 100 Supply voltage 12/24 V DC, 2 analog inputs Pt100, temperature range -50 °C ... 200 °C	6ED1 055-1MD00-0BA1	
LOGO! AM2 AQ Supply voltage 24 V DC, 2 analog outputs 0 to 10 V, 0/4 to 20 mA	6ED1 055-1MM00-0BA1	
		Accessories LOGO! Manual German 6ED1 050-1AA00-0AE8 English 6ED1 050-1AA00-0BE8 French 6ED1 050-1AA00-0CE8 Spanish 6ED1 050-1AA00-0DE8 Italian 6ED1 050-1AA00-0EE8 Chinese 6ED1 050-1AA00-0KE8 LOGO! Memory Card 6ED1 056-1DA00-0BA0 for copying, with know-how protection LOGO!Soft Comfort V7.0 6ED1 058-0BA02-0YA1 For programming on the PC in LAD/FBD; executes on Windows 7, VISTA, XP, NT4.0, 2000, 98SE, Linux and MAC OSX; on CD-ROM LOGO!Soft Comfort V7.0 upgrade 6ED1 058-0CA02-0YE1 Upgrade from V1.0 to V7.0 LOGO! PC cable 6ED1 057-1AA00-0BA0 For program transfer between LOGO! and the PC

Overview



- Expansion modules for connection to LOGO! modular
- With digital inputs and outputs, analog inputs, or analog outputs

Note:

SIPLUS extreme products are based on Siemens Industry standard products. The contents listed here were taken from the respective standard products. SIPLUS extreme-specific information was added.

2

Technical specifications

The technical data correspond to those of the based-on modules apart from the values listed in the table:

Based on	6AG1 055-1CB00-2XB0 6ED1 055-1CB00-0BA0	6AG1 055-1CB00-2BY0 6ED1 055-1CB00-0BA0	6AG1 055-1PB00-2XB0 6ED1 055-1CB00-0BA0	6AG1 055-1PB00-2BY0 6ED1 055-1CB00-0BA0
Ambient conditions				
Operating temperature				
• Min.	-25 °C; = Tmin	-40 °C; = Tmin	-25 °C; = Tmin	-40 °C; = Tmin
• max.	70 °C; = Tmax; 55 °C @ UL/cUL use	70 °C; = Tmax; 55 °C @ UL/cUL use	70 °C; = Tmax; 55 °C @ UL/cUL use	70 °C; = Tmax; 55 °C @ UL/cUL use
Extended ambient conditions				
• Relative to ambient temperature-atmospheric pressure-installation altitude	Tmin ... Tmax at 1080 hPa ... 795 hPa (-1000 m ... +2000 m) // Tmin ... (Tmax - 10K) at 795 hPa ... 658 hPa (+2000 m ... +3500 m) // Tmin ... (Tmax - 20K) at 658 hPa ... 540 hPa (+3500 m ... +5000 m)	Tmin ... Tmax at 1080 hPa ... 795 hPa (-1000 m ... +2000 m) // Tmin ... (Tmax - 10K) at 795 hPa ... 658 hPa (+2000 m ... +3500 m) // Tmin ... (Tmax - 20K) at 658 hPa ... 540 hPa (+3500 m ... +5000 m)	Tmin ... Tmax at 1080 hPa ... 795 hPa (-1000 m ... +2000 m) // Tmin ... (Tmax - 10K) at 795 hPa ... 658 hPa (+2000 m ... +3500 m) // Tmin ... (Tmax - 20K) at 658 hPa ... 540 hPa (+3500 m ... +5000 m)	Tmin ... Tmax at 1080 hPa ... 795 hPa (-1000 m ... +2000 m) // Tmin ... (Tmax - 10K) at 795 hPa ... 658 hPa (+2000 m ... +3500 m) // Tmin ... (Tmax - 20K) at 658 hPa ... 540 hPa (+3500 m ... +5000 m)
• Relative humidity				
- with condensation	100 %; Relative humidity, incl. condensation / frost permitted (no commissioning under condensation conditions)	100 %; Relative humidity, incl. condensation / frost permitted (no commissioning under condensation conditions)	100 %; Relative humidity, incl. condensation / frost permitted (no commissioning under condensation conditions)	100 %; Relative humidity, incl. condensation / frost permitted (no commissioning under condensation conditions)
• Resistance				
- to biologically active substances	Yes; Class 3B2 mold, fungus and dry rot spores (with the exception of fauna). The supplied connector covers must remain on the unused interfaces during operation!	Yes; Class 3B2 mold, fungus and dry rot spores (with the exception of fauna). The supplied connector covers must remain on the unused interfaces during operation!	Yes; Class 3B2 mold, fungus and dry rot spores (with the exception of fauna). The supplied connector covers must remain on the unused interfaces during operation!	Yes; Class 3B2 mold, fungus and dry rot spores (with the exception of fauna). The supplied connector covers must remain on the unused interfaces during operation!
- to chemically active substances	Yes; Class 3C4 incl. salt spray. The supplied connector covers must remain on the unused interfaces during operation!	Yes; Class 3C4 incl. salt spray. The supplied connector covers must remain on the unused interfaces during operation!	Yes; Class 3C4 incl. salt spray. The supplied connector covers must remain on the unused interfaces during operation!	Yes; Class 3C4 incl. salt spray. The supplied connector covers must remain on the unused interfaces during operation!
- to mechanically active substances	Yes; Class 3S4 incl. sand, dust. The supplied connector covers must remain on the unused interfaces during operation!	Yes; Class 3S4 incl. sand, dust. The supplied connector covers must remain on the unused interfaces during operation!	Yes; Class 3S4 incl. sand, dust. The supplied connector covers must remain on the unused interfaces during operation!	Yes; Class 3S4 incl. sand, dust. The supplied connector covers must remain on the unused interfaces during operation!

LOGO! logic module

LOGO! modular

SIPLUS LOGO! modular expansion modules

Technical specifications (continued)

	6AG1 055-1HB00-2XB0 6ED1 055-1HB00-0BA0	6AG1 055-1HB00-2BY0 6ED1 055-1HB00-0BA0	6AG1 055-1MB00-2XB1 6ED1 055-1MB00-0BA1	6AG1 055-1MB00-2BY1 6ED1 055-1MB00-0BA1
Based on				
Ambient conditions				
Operating temperature				
• Min.	-25 °C; = Tmin	-40 °C; = Tmin	-25 °C; = Tmin	-40 °C; = Tmin
• max.	70 °C; = Tmax; 55 °C @ UL/cUL use	70 °C; = Tmax; 55 °C @ UL/cUL use	70 °C; = Tmax; 55 °C @ UL/cUL use	70 °C; = Tmax; 55 °C @ UL/cUL use
Extended ambient conditions				
• Relative to ambient temperature-atmospheric pressure-installation altitude	Tmin ... Tmax at 1080 hPa ... 795 hPa (-1000 m ... +2000 m) // Tmin ... (Tmax - 10K) at 795 hPa ... 658 hPa (+2000 m ... +3500 m) // Tmin ... (Tmax - 20K) at 658 hPa ... 540 hPa (+3500 m ... +5000 m)	Tmin ... Tmax at 1080 hPa ... 795 hPa (-1000 m ... +2000 m) // Tmin ... (Tmax - 10K) at 795 hPa ... 658 hPa (+2000 m ... +3500 m) // Tmin ... (Tmax - 20K) at 658 hPa ... 540 hPa (+3500 m ... +5000 m)	Tmin ... Tmax at 1080 hPa ... 795 hPa (-1000 m ... +2000 m) // Tmin ... (Tmax - 10K) at 795 hPa ... 658 hPa (+2000 m ... +3500 m) // Tmin ... (Tmax - 20K) at 658 hPa ... 540 hPa (+3500 m ... +5000 m)	Tmin ... Tmax at 1080 hPa ... 795 hPa (-1000 m ... +2000 m) // Tmin ... (Tmax - 10K) at 795 hPa ... 658 hPa (+2000 m ... +3500 m) // Tmin ... (Tmax - 20K) at 658 hPa ... 540 hPa (+3500 m ... +5000 m)
• Relative humidity				
- with condensation	100 %; Relative humidity, incl. condensation / frost permitted (no commissioning under condensation conditions)	100 %; Relative humidity, incl. condensation / frost permitted (no commissioning under condensation conditions)	100 %; Relative humidity, incl. condensation / frost permitted (no commissioning under condensation conditions)	100 %; Relative humidity, incl. condensation / frost permitted (no commissioning under condensation conditions)
• Resistance				
- to biologically active substances	Yes; Class 3B2 mold, fungus and dry rot spores (with the exception of fauna). The supplied connector covers must remain on the unused interfaces during operation!	Yes; Class 3B2 mold, fungus and dry rot spores (with the exception of fauna). The supplied connector covers must remain on the unused interfaces during operation!	Yes; Class 3B2 mold, fungus and dry rot spores (with the exception of fauna). The supplied connector covers must remain on the unused interfaces during operation!	Yes; Class 3B2 mold, fungus and dry rot spores (with the exception of fauna). The supplied connector covers must remain on the unused interfaces during operation!
- to chemically active substances	Yes; Class 3C4 incl. salt spray. The supplied connector covers must remain on the unused interfaces during operation!	Yes; Class 3C4 incl. salt spray. The supplied connector covers must remain on the unused interfaces during operation!	Yes; Class 3C4 incl. salt spray. The supplied connector covers must remain on the unused interfaces during operation!	Yes; Class 3C4 incl. salt spray. The supplied connector covers must remain on the unused interfaces during operation!
- to mechanically active substances	Yes; Class 3S4 incl. sand, dust. The supplied connector covers must remain on the unused interfaces during operation!	Yes; Class 3S4 incl. sand, dust. The supplied connector covers must remain on the unused interfaces during operation!	Yes; Class 3S4 incl. sand, dust. The supplied connector covers must remain on the unused interfaces during operation!	Yes; Class 3S4 incl. sand, dust. The supplied connector covers must remain on the unused interfaces during operation!
Bases on	6AG1 055-1FB00-2XB1 6ED1 055-1FB00-0BA1	6AG1 055-1FB00-2BY1 6ED1 055-1FB00-0BA1	6AG1 055-1NB10-2BA0 6ED1 055-1NB10-0BA0	
Ambient conditions				
Operating temperature				
• Min.	-25 °C; = Tmin	-40 °C; = Tmin	-25 °C; = Tmin	
• max.	70 °C; = Tmax; 55 °C @ UL/cUL use	70 °C; = Tmax; 55 °C @ UL/cUL use	70 °C; = Tmax; 55 °C @ UL/cUL use	
Extended ambient conditions				
• Relative to ambient temperature-atmospheric pressure-installation altitude	Tmin ... Tmax at 1080 hPa ... 795 hPa (-1000 m ... +2000 m)	Tmin ... Tmax at 1080 hPa ... 795 hPa (-1000 m ... +2000 m)	Tmin ... Tmax at 1080 hPa ... 795 hPa (-1000 m ... +2000 m) // Tmin ... (Tmax - 10K) at 795 hPa ... 658 hPa (+2000 m ... +3500 m) // Tmin ... (Tmax - 20K) at 658 hPa ... 540 hPa (+3500 m ... +5000 m)	
• Relative humidity				
- with condensation	100 %; Relative humidity, incl. condensation / frost permitted (no commissioning under condensation conditions)	100 %; Relative humidity, incl. condensation / frost permitted (no commissioning under condensation conditions)	100 %; Relative humidity, incl. condensation / frost permitted (no commissioning under condensation conditions)	
• Resistance				
- to biologically active substances	Yes; Class 3B2 mold, fungus and dry rot spores (with the exception of fauna). The supplied connector covers must remain on the unused interfaces during operation!	Yes; Class 3B2 mold, fungus and dry rot spores (with the exception of fauna). The supplied connector covers must remain on the unused interfaces during operation!	Yes; Class 3B2 mold, fungus and dry rot spores (with the exception of fauna). The supplied connector covers must remain on the unused interfaces during operation!	
- to chemically active substances	Yes; Class 3C4 incl. salt spray. The supplied connector covers must remain on the unused interfaces during operation!	Yes; Class 3C4 incl. salt spray. The supplied connector covers must remain on the unused interfaces during operation!	Yes; Class 3C4 incl. salt spray. The supplied connector covers must remain on the unused interfaces during operation!	
- to mechanically active substances	Yes; Class 3S4 incl. sand, dust. The supplied connector covers must remain on the unused interfaces during operation!	Yes; Class 3S4 incl. sand, dust. The supplied connector covers must remain on the unused interfaces during operation!	Yes; Class 3S4 incl. sand, dust. The supplied connector covers must remain on the unused interfaces during operation!	

Technical specifications (continued)

	6AG1 055-1MA00-2XB0	6AG1 055-1MA00-2BY0	6AG1 055-1MM00-2BY1
Based on	6ED1 055-1MA00-0BA0	6ED1 055-1MA00-0BA0	6ED1 055-1MM00-0BA1
Ambient conditions			
Operating temperature			
• Min.	-25 °C; = Tmin	-40 °C; = Tmin	-40 °C; = Tmin
• max.	70 °C; = Tmax; 55 °C @ UL/cUL use	70 °C; = Tmax; 55 °C @ UL/cUL use	70 °C; = Tmax; 55 °C @ UL/cUL use
Extended ambient conditions			
• Relative to ambient temperature-atmospheric pressure-installation altitude	Tmin ... Tmax at 1080 hPa ... 795 hPa (-1000 m ... +2000 m) // Tmin ... (Tmax - 10K) at 795 hPa ... 658 hPa (+2000 m ... +3500 m) // Tmin ... (Tmax - 20K) at 658 hPa ... 540 hPa (+3500 m ... +5000 m)	Tmin ... Tmax at 1080 hPa ... 795 hPa (-1000 m ... +2000 m) // Tmin ... (Tmax - 10K) at 795 hPa ... 658 hPa (+2000 m ... +3500 m) // Tmin ... (Tmax - 20K) at 658 hPa ... 540 hPa (+3500 m ... +5000 m)	Tmin ... Tmax at 1080 hPa ... 795 hPa (-1000 m ... +2000 m) // Tmin ... (Tmax - 10K) at 795 hPa ... 658 hPa (+2000 m ... +3500 m) // Tmin ... (Tmax - 20K) at 658 hPa ... 540 hPa (+3500 m ... +5000 m)
• Relative humidity - with condensation	100 %; Relative humidity, incl. condensation / frost permitted (no commissioning under condensation conditions)	100 %; Relative humidity, incl. condensation / frost permitted (no commissioning under condensation conditions)	100 %; Relative humidity, incl. condensation / frost permitted (no commissioning under condensation conditions)
• Resistance - to biologically active substances	Yes; Class 3B2 mold, fungus and dry rot spores (with the exception of fauna). The supplied connector covers must remain on the unused interfaces during operation!	Yes; Class 3B2 mold, fungus and dry rot spores (with the exception of fauna). The supplied connector covers must remain on the unused interfaces during operation!	Yes; Class 3B2 mold, fungus and dry rot spores (with the exception of fauna). The supplied connector covers must remain on the unused interfaces during operation!
- to chemically active substances	Yes; Class 3C4 incl. salt spray. The supplied connector covers must remain on the unused interfaces during operation!	Yes; Class 3C4 incl. salt spray. The supplied connector covers must remain on the unused interfaces during operation!	Yes; Class 3C4 incl. salt spray. The supplied connector covers must remain on the unused interfaces during operation!
- to mechanically active substances	Yes; Class 3S4 incl. sand, dust. The supplied connector covers must remain on the unused interfaces during operation!	Yes; Class 3S4 incl. sand, dust. The supplied connector covers must remain on the unused interfaces during operation!	Yes; Class 3S4 incl. sand, dust. The supplied connector covers must remain on the unused interfaces during operation!

LOGO! logic module

LOGO! modular

SIPLUS LOGO! modular expansion modules

2

Ordering data	Order No.	Ordering data	Order No.
SIPLUS LOGO! DM8 24 (extended temperature range and medial exposure) 24 V DC supply voltage, 4 digital inputs 24 V DC, 4 digital outputs 24 V DC, 0.3 A Temperature range -25 ... +70 °C Temperature range -40 ... +70 °C	6AG1 055-1CB00-2XB0 6AG1 055-1CB00-2BY0	SIPLUS LOGO! AM2 (extended temperature range and medial exposure) 12/24 V DC supply voltage, 2 analog inputs 0 ... 10 V or 0 ... 20 mA, 10-bit resolution Temperature range -25 ... +70 °C Temperature range -40 ... +70 °C	6AG1 055-1MA00-2XB0 6AG1 055-1MA00-2BY0
SIPLUS LOGO! DM8 12/24 (extended temperature range and medial exposure) 12/24 V DC supply voltage, 4 digital inputs 12/24 V DC, 4 digital outputs 24 V DC, 0.3 A Temperature range -25 ... +70 °C Temperature range -40 ... +70 °C	6AG1 055-1PB00-2XB0 6AG1 055-1PB00-2BY0	SIPLUS LOGO! AM2 AQ (extended temperature range and medial exposure) 24 V DC supply voltage, 2 analog inputs 0 ... 10 V, 0/4 ... 20 mA, 10-bit resolution Temperature range -40 ... +70 °C	6AG1 055-1MM00-2BY1
SIPLUS LOGO! DM8 24R (extended temperature range and medial exposure) 24 V AC/DC supply voltage, 4 digital inputs 24 V AC/DC, 4 relay outputs 5 A Temperature range -25 ... +70 °C Temperature range -40 ... +70 °C	6AG1 055-1HB00-2XB0 6AG1 055-1HB00-2BY0	SIPLUS LOGO! DM16 24R (extended temperature range and medial exposure) 24 V DC supply voltage, 8 digital outputs 24 V DC, 8 relay outputs 5 A Temperature range -25 ... +70 °C	6AG1 055-1NB10-2BA0
SIPLUS LOGO! DM8 12/24R (extended temperature range and medial exposure) 12/24 V DC supply voltage, 4 digital inputs 12/24 V DC, 4 relay outputs 5 A Temperature range -25 ... +70 °C Temperature range -40 ... +70 °C	6AG1 055-1MB00-2XB1 6AG1 055-1MB00-2BY1	Accessories SIPLUS Upmiter upstream device for reliable operation at the battery of combustion engines	6AG1 053-1AA00-2AA0
SIPLUS LOGO! DM8 230R (extended temperature range and medial exposure) 115/230 V AC/DC supply voltage, 4 digital inputs 115/230 V AC/DC, 4 relay outputs 5 A Temperature range -25 ... +70 °C Temperature range -40 ... +70 °C	6AG1 055-1FB00-2XB1 6AG1 055-1FB00-2BY1	Additional accessories	See LOGO! modular pure variants, page 2/18

LOGO! CM EIB/KNX communication modules

Overview



- Expansion module for LOGO! basic versions
- For communication between the LOGO! master and external *EIB* components through *EIB*

Technical specifications

CM EIB/KNX	
Supply voltage	24 V AC/DC
Inputs, max.	16 DI/12 DO/8 AI/2 AO
Outputs, max.	16 digital
Continuous current	25 mA
Short-circuit protection	External fuse protection is required
Integrated time switches/power reserve	-
Ambient temperature	0 ... +55°C
RI specification	To EN 55 011 (limit class B)
Degree of protection	IP20
Certification	to VDE 0631, IEC61131-2, cULus, FM
Mounting	On DIN rail 35 mm, 2 module widths wide
Dimensions (W x H x D) in mm	36 (2 MW) x 90 x 55

Ordering data

Order No.

**LOGO! communication module
CM EIB KNX** **6BK1 700-0BA00-0AA2**

for connection to *EIB*,
supply voltage 24 V DC

Accessories

LOGO! Manual

German	6ED1 050-1AA00-0AE8
English	6ED1 050-1AA00-0BE8
French	6ED1 050-1AA00-0CE8
Spanish	6ED1 050-1AA00-0DE8
Italian	6ED1 050-1AA00-0EE8
Chinese	6ED1 050-1AA00-0KE8

LOGO! logic module

LOGO! modular

LOGO! CSM unmanaged

Overview

2



The module is used to connect a LOGO! and up to three other nodes to an Industrial Ethernet network with 10/100 Mbit/s in an electrical linear, tree or star topology.

The essential features of the LOGO! CSM are:

- Unmanaged 4-port switch, of which one port is on the front for easy diagnostics access
- Two versions for the voltage ranges 12/24 V DC or 230 V AC/DC
- Problem-free connection using four RJ45 standard connectors
- Space-saving, optimized for connection to LOGO!
- Low-cost solution for implementing small, local Ethernet networks
- Stand-alone use for networking any Ethernet devices

Technical specifications

Order No.	6GK7 177-1FA10-0AA0	6GK7 177-1MA10-0AA0
Product-type designation	LOGO! CSM 230	LOGO! CSM 12/24
Transmission rate		
Transfer rate 1	10 Mbit/s	10 Mbit/s
Transfer rate 2	100 Mbit/s	100 Mbit/s
Interfaces		
Number of electrical/optical connections for network components or terminal equipment maximum	4	4
Number of electrical connections		
• for network components and terminal equipment	4	4
• for power supply	1	1
Design of electrical connection		
• for network components and terminal equipment	RJ45 port / 1 connection on front of module	RJ45 port / 1 connection on front of module
• for power supply	3-pole terminal block	3-pole terminal block
Supply voltage, current consumption, power loss		
Type of voltage of supply voltage	AC/DC 115...240 V	DC 12/24 V
Supply voltage external	230 V	24 V
• minimum	100 V	10.2 V
• maximum	240 V	30.2 V
Product component fusing at power supply input	Yes	Yes
Consumed current maximum	0.02 A	0.15 A
Active power loss at 24 V for DC	-	1.5 W
Permitted ambient conditions		
Ambient temperature		
• during operating	0 ... 55 °C	0 ... 55 °C
• during storage	-40 °C 70 °C	-40 °C 70 °C
• during transport	-40 °C	-40 °C

Order No.	6GK7 177-1FA10-0AA0	6GK7 177-1MA10-0AA0
Product-type designation	LOGO! CSM 230	LOGO! CSM 12/24
Relative humidity at 25 °C without condensation during operating maximum		
	90 %	90 %
Protection class IP		
	IP20	IP20
Design, dimensions and weight		
Design	LOGO! module	LOGO! module
Width	72 mm	72 mm
Height	90 mm	90 mm
Depth	55 mm	55 mm
Net weight	0.155 kg	0.14 kg
Type of mounting		
• 35 mm DIN rail mounting	Yes	Yes
• wall mounting	Yes	Yes
• S7-300 rail mounting	No	No
Product functions		
Management, configuration		
Product function switch-managed	No	No
Standards, specifications, approvals		
Standard		
• for EMC from FM	avail. soon	avail. soon
• for safety of CSA and UL	avail. soon	avail. soon
• CE mark	Yes	Yes
• C-Tick	Yes	Yes
• KC approval	No	No

Ordering data	Order No.	Accessories	Order No.
<p>LOGO! CSM Compact Switch Modules</p> <p>Unmanaged switch for connecting a LOGO! (...0BA7) and up to three further nodes on Industrial Ethernet with 10/100 Mbit/s; 4 x RJ45 ports; LED diagnostics, LOGO! module</p> <ul style="list-style-type: none"> • LOGO! CSM 12/24 external 12 V DC or 24 V DC power supply, • LOGO! CSM 230 external 115 ... 240 V AC power supply 	<p>6GK7 177-1MA10-0AA0</p> <p>6GK7 177-1FA10-0AA0</p>	<p>IE TP Cord RJ45/RJ45</p> <p>TP cable 4 x 2 with 2 RJ45 connectors</p> <ul style="list-style-type: none"> • 0.5 m • 1 m • 2 m • 6 m • 10 m <p>IE FC Outlet RJ45</p> <p>For connecting Industrial Ethernet FC cables and TP cords; graduated prices for 10 and 50 units or more</p>	<p>6XV1 870-3QE50</p> <p>6XV1 870-3QH10</p> <p>6XV1 870-3QH20</p> <p>6XV1 870-3QH60</p> <p>6XV1 870-3QN10</p> <p>6GK1 901-1FC00-0AA0</p>

LOGO! logic module

LOGO! modular

AS-Interface connection for LOGO!

Overview

Each LOGO! can now be connected to the AS-Interface system

Ordering data

Order No.

AS-Interface connection for LOGO!

3RK1 400-0CE10-0AA2



An intelligent slave can be integrated into the AS-Interface system with the AS-Interface for LOGO!. The modular interface allows the different basic units to be integrated into the system depending on the required functionality. In addition, the functionality can be quickly and simply adapted to changed requirements by replacing the basic unit.

The interface provides four inputs and four outputs for the system. These I/Os, however, are not implemented in hardware, but are only virtually available via the interface.

Overview



The flat power supply unit for distribution boards

The new miniature power supply units now offer even greater performance in the smallest space: The efficiency has been improved across the entire load range, and the power loss in

no-load operation has been cut in half. The wide-range input now also allows operation with direct voltage, the switch-on behavior has been optimized for capacitive loads, and the operating temperature range has been extended to +70 °C. The power supplies with logic module design can be used extremely flexibly in numerous applications – thanks to their flat, stepped profile in distribution boards, for example.

Essential product features

- 2 performance classes, each with 5 V, 12 V, and 15 V
- 3 performance classes with 24 V
- Flat LOGO! design
- Wide-range input for 85 V to 264 V AC or 110 V to 300 V DC
- Constant current for connection of loads with high inrush current
- Power reserve on starting up through 1.5 times the rated current for capacitive loads
- Adjustable output voltage
- Green LED for "Output voltage OK"
- Temperature range from –20 °C to +70 °C
- Comprehensive certification, e.g. ATEX and GL

Technical specifications

Order No.	6EP1 311-1SH03	6EP1 311-1SH13
Product	LOGO!Power	LOGO!Power
Power supply, type	5 V/3 A	5 V/6.3 A
Input		
Input	1-phase AC or DC	1-phase AC or DC
Rated voltage value V_{in} rated	100 ... 240 V	100 ... 240 V
Voltage range	85 ... 264 V	85 ... 264 V
Input voltage at DC	110 ... 300 V	110 ... 300 V
Oversvoltage resistance	$2.3 \times V_{in}$ rated, 1.3 ms	$2.3 \times V_{in}$ rated, 1.3 ms
Mains buffering at I_{out} rated, min.	0.04 s	0.04 s
Mains buffering	at $V_{in} = 187$ V	at $V_{in} = 187$ V
Rated line frequency		
• 1	50 Hz	50 Hz
• 2	60 Hz	60 Hz
Rated line range	47 ... 63 Hz	47 ... 63 Hz
Input current		
• at nominal level of the input voltage 120 V nominal value	0.36 A	0.71 A
• at nominal level of the input voltage 230 V nominal value	0.22 A	0.37 A
Switch-on current limiting (+25 °C), max.	26 A	50 A
I^2t , max.	0.8 A ² ·s	3 A ² ·s
Built-in incoming fuse	internal	internal
Protection in the mains power input (IEC 898)	Recommended miniature circuit breaker: from 16 A, characteristic B or from 10 A, characteristic C	Recommended miniature circuit breaker: from 16 A, characteristic B or from 10 A, characteristic C

LOGO! logic module

LOGO!Power

LOGO!Power

Technical specifications (continued)

Order No.	6EP1 311-1SH03	6EP1 311-1SH13
Product	LOGO!Power	LOGO!Power
Power supply, type	5 V/3 A	5 V/6.3 A
Output		
Output	Controlled, isolated DC voltage	Controlled, isolated DC voltage
Rated voltage Vout DC	5 V	5 V
Total tolerance, static ±	3 %	3 %
Static mains compensation, approx.	0.2 %	0.1 %
Static load balancing, approx.	1.5 %	2 %
Residual ripple peak-peak, max.	100 mV	100 mV
Residual ripple peak-peak, typ.	10 mV	15 mV
Spikes peak-peak, max. (bandwidth: 20 MHz)	100 mV	100 mV
Spikes peak-peak, typ. (bandwidth: 20 MHz)	20 mV	70 mV
Adjustment range	4.6 ... 5.4 V	4.6 ... 5.4 V
Product feature output voltage adjustable	Yes	Yes
Output voltage setting	via potentiometer	via potentiometer
Status display	Green LED for output voltage OK	Green LED for output voltage OK
On/off behavior	No overshoot of Vout (soft start)	No overshoot of Vout (soft start)
Startup delay, max.	0.5 s	0.5 s
Voltage rise, typ.	20 ms	10 ms
Rated current value Iout rated	3 A	6.3 A
Current range	0 ... 3 A	0 ... 6.3 A
Note	3 A up to +55 °C, 2.1 A up to +70 °C	6.3 A up to +55 °C, 4.4 A up to +70 °C
delivered active power typ.	15 W	30 W
Parallel switching for enhanced performance	Yes	Yes
Numbers of parallel switchable units for enhanced performance	2	2
Efficiency		
Efficiency at Vout rated, Iout rated, approx.	77 %	83 %
Power loss at Vout rated, Iout rated, approx.	4 W	6 W
Closed-loop control		
Dynamic mains compensation (Vin rated ±15 %), max.	0.2 %	0.2 %
Dynamic load smoothing (Iout: 10/90/10 %), Uout ± typ.	3 %	3 %
Load step setting time 10 to 90%, typ.	2 ms	2 ms
Load step setting time 90 to 10%, typ.	2 ms	2 ms
Protection and monitoring		
Output overvoltage protection	Yes, according to EN 60950	Yes, according to EN 60950
Current limitation, typ.	3.8 A	8.2 A
Characteristic feature of the output short-circuit protected	Yes	Yes
Short-circuit protection	Constant current characteristic	Constant current characteristic
Enduring short circuit current Effective level maximum	5 A	10 A
Overload/short-circuit indicator	-	-

Technical specifications (continued)

Order No.	6EP1 311-1SH03	6EP1 311-1SH13
Product	LOGO!Power	LOGO!Power
Power supply, type	5 V/3 A	5 V/6.3 A
Safety		
Primary/secondary isolation	Yes	Yes
Potential separation	Safety extra-low output voltage U _{out} acc. to EN 60950-1 and EN 50178	Safety extra-low output voltage U _{out} acc. to EN 60950-1 and EN 50178
Protection class	Class II (without protective conductor)	Class II (without protective conductor)
CE mark	Yes	Yes
UL/CSA approval	Yes	Yes
UL/cUL (CSA) approval	cULus-listed (UL 508, CSA C22.2 No. 107.1), File E197259; cURus-recognized (UL 60950, CSA C22.2 No. 60950), File E151273	cULus-listed (UL 508, CSA C22.2 No. 107.1), File E197259; cURus-recognized (UL 60950, CSA C22.2 No. 60950), File E151273
Explosion protection	ATEX (EX) II 3G Ex nA IIC T3; cCSAus (CSA E60079, UL 60079), Class I, Div. 2, Group ABCD, T4	ATEX (EX) II 3G Ex nA IIC T3; cCSAus (CSA E60079, UL 60079), Class I, Div. 2, Group ABCD, T4
FM approval	Yes	Yes
FM approval	Class I, Div. 2, Group ABCD, T4	Class I, Div. 2, Group ABCD, T4
CB approval	Yes	Yes
Marine approval	GL, ABS	GL, ABS
Degree of protection (EN 60529)	IP20	IP20
EMC		
Emitted interference	EN 55022 Class B	EN 55022 Class B
Supply harmonics limitation	not applicable	not applicable
Noise immunity	EN 61000-6-2	EN 61000-6-2
Operating data		
Ambient temperature		
• in operation	-20 ... +70 °C	-20 ... +70 °C
- Note	with natural convection	with natural convection
• on transport	-40 ... +85 °C	-40 ... +85 °C
• in storage	-40 ... +85 °C	-40 ... +85 °C
Humidity class according to EN 60721	Climate class 3K3, no condensation	Climate class 3K3, no condensation
Mechanics		
Connection technology	screw-type terminals	screw-type terminals
Connections		
• Supply input	L, N: 1 screw terminal each for 0.5 ... 2.5 mm ² single-core/finely stranded	L, N: 1 screw terminal each for 0.5 ... 2.5 mm ² single-core/finely stranded
• Output	+, -: 2 screw terminals each for 0.5 ... 2.5 mm ²	+, -: 2 screw terminals each for 0.5 ... 2.5 mm ²
• Auxiliary	-	-
Width of the housing	54 mm	0.072 m
Height of the housing	90 mm	90 mm
Depth of the housing	55 mm	55 mm
Installation width	54 mm	72 mm
Installation height	130 mm	130 mm
Weight, approx.	0.17 kg	0.25 kg
Product feature of the housing housing for side-by-side mounting	Yes	Yes
Type of mounting wall mounting	No	No
Type of fixing cap rail mounting	Yes	Yes
Type of mounting S7-300 rail mounting	No	No
Installation	Snaps onto DIN rail EN 60715 35x7.5/15	Snaps onto DIN rail EN 60715 35x7.5/15

LOGO! logic module

LOGO!Power

LOGO!Power

Technical specifications (continued)

Order No.	6EP1 321-1SH03	6EP1 322-1SH03
Product	LOGO!Power	LOGO!Power
Power supply, type	12 V/1.9 A	12 V/4.5 A
Input		
Input	1-phase AC or DC	1-phase AC or DC
Rated voltage value V_{in} rated	100 ... 240 V	100 ... 240 V
Voltage range	85 ... 264 V	85 ... 264 V
Input voltage at DC	110 ... 300 V	110 ... 300 V
Oversvoltage resistance	$2.3 \times V_{in}$ rated, 1.3 ms	$2.3 \times V_{in}$ rated, 1.3 ms
Mains buffering at I_{out} rated, min.	40 ms	40 ms
Mains buffering	at $V_{in} = 187$ V	at $V_{in} = 187$ V
Rated line frequency		
• 1	50 Hz	50 Hz
• 2	60 Hz	60 Hz
Rated line range	47 ... 63 Hz	47 ... 63 Hz
Input current		
• at nominal level of the input voltage 120 V nominal value	0.53 A	1.13 A
• at nominal level of the input voltage 230 V nominal value	0.3 A	0.61 A
Switch-on current limiting (+25 °C), max.	25 A	55 A
I^2t , max.	0.8 A ² ·s	3 A ² ·s
Built-in incoming fuse	internal	internal
Protection in the mains power input (IEC 898)	Recommended miniature circuit breaker: from 16 A, characteristic B or from 10 A, characteristic C	Recommended miniature circuit breaker: from 16 A, characteristic B or from 10 A, characteristic C
Output		
Output	Controlled, isolated DC voltage	Controlled, isolated DC voltage
Rated voltage V_{out} DC	12 V	12 V
Total tolerance, static \pm	3 %	3 %
Static mains compensation, approx.	0.1 %	0.1 %
Static load balancing, approx.	1.5 %	1.5 %
Residual ripple peak-peak, max.	200 mV	200 mV
Residual ripple peak-peak, typ.	10 mV	10 mV
Spikes peak-peak, max. (bandwidth: 20 MHz)	300 mV	300 mV
Spikes peak-peak, typ. (bandwidth: 20 MHz)	20 mV	70 mV
Adjustment range	10.5 ... 16.1 V	10.5 ... 16.1 V
Product feature output voltage adjustable	Yes	Yes
Output voltage setting	via potentiometer	via potentiometer
Status display	Green LED for output voltage OK	Green LED for output voltage OK
On/off behavior	No overshoot of V_{out} (soft start)	No overshoot of V_{out} (soft start)
Startup delay, max.	0.5 s	0.5 s
Voltage rise, typ.	10 ms	10 ms
Rated current value I_{out} rated	1.9 A	4.5 A
Current range	0 ... 1.9 A	0 ... 4.5 A
Note	1.9 A up to +55 °C, 1.3 A up to +70 °C	4.5 A up to +55 °C, 3.1 A up to +70 °C
delivered active power typ.	23 W	50 W
Parallel switching for enhanced performance	Yes	Yes
Numbers of parallel switchable units for enhanced performance	2	2
Efficiency		
Efficiency at V_{out} rated, I_{out} rated, approx.	80 %	85 %
Power loss at V_{out} rated, I_{out} rated, approx.	5 W	10 W

Technical specifications (continued)

Order No.	6EP1 321-1SH03	6EP1 322-1SH03
Product	LOGO!Power	LOGO!Power
Power supply, type	12 V/1.9 A	12 V/4.5 A
Closed-loop control		
Dynamic mains compensation (Vin rated ±15 %), max.	0.2 %	0.2 %
Dynamic load smoothing (Iout: 10/90/10 %), Uout ± typ.	3 %	4 %
Load step setting time 10 to 90%, typ.	1 ms	1 ms
Load step setting time 90 to 10%, typ.	1 ms	1 ms
Protection and monitoring		
Output overvoltage protection	Yes, according to EN 60950	Yes, according to EN 60950
Current limitation, typ.	2.8 A	5.8 A
Characteristic feature of the output short-circuit protected	Yes	Yes
Short-circuit protection	Constant current characteristic	Constant current characteristic
Enduring short circuit current Effective level maximum	3.6 A	7 A
Overload/short-circuit indicator	-	-
Safety		
Primary/secondary isolation	Yes	Yes
Potential separation	Safety extra-low output voltage Uout acc. to EN 60950-1 and EN 50178	Safety extra-low output voltage Uout acc. to EN 60950-1 and EN 50178
Protection class	Class II (without protective conductor)	Class II (without protective conductor)
CE mark	Yes	Yes
UL/CSA approval	Yes	Yes
UL/cUL (CSA) approval	cULus-listed (UL 508, CSA C22.2 No. 107.1), File E197259; cURus-recognized (UL 60950, CSA C22.2 No. 60950), File E151273	cULus-listed (UL 508, CSA C22.2 No. 107.1), File E197259; cURus-recognized (UL 60950, CSA C22.2 No. 60950), File E151273
Explosion protection	ATEX (EX) II 3G Ex nA IIC T3; cCSAus (CSA E60079, UL 60079), Class I, Div. 2, Group ABCD, T4	ATEX (EX) II 3G Ex nA IIC T3; cCSAus (CSA E60079, UL 60079), Class I, Div. 2, Group ABCD, T4
FM approval	Yes	Yes
FM approval	Class I, Div. 2, Group ABCD, T4	Class I, Div. 2, Group ABCD, T4
CB approval	Yes	Yes
Marine approval	GL, ABS	GL, ABS
Degree of protection (EN 60529)	IP20	IP20
EMC		
Emitted interference	EN 55022 Class B	EN 55022 Class B
Supply harmonics limitation	not applicable	not applicable
Noise immunity	EN 61000-6-2	EN 61000-6-2
Operating data		
Ambient temperature		
• in operation	-20 ... +70 °C	-20 ... +70 °C
- Note	with natural convection	with natural convection
• on transport	-40 ... +85 °C	-40 ... +85 °C
• in storage	-40 ... +85 °C	-40 ... +85 °C
Humidity class according to EN 60721	Climate class 3K3, no condensation	Climate class 3K3, no condensation

LOGO! logic module

LOGO!Power

LOGO!Power

Technical specifications (continued)

Order No.	6EP1 321-1SH03	6EP1 322-1SH03
Product	LOGO!Power	LOGO!Power
Power supply, type	12 V/1.9 A	12 V/4.5 A
Mechanics		
Connection technology	screw-type terminals	screw-type terminals
Connections		
• Supply input	L, N: 1 screw terminal each for 0.5 ... 2.5 mm ² single-core/finely stranded	L, N: 1 screw terminal each for 0.5 ... 2.5 mm ² single-core/finely stranded
• Output	+, -: 2 screw terminals each for 0.5 ... 2.5 mm ²	+, -: 2 screw terminals each for 0.5 ... 2.5 mm ²
• Auxiliary	-	-
Width of the housing	54 mm	72 mm
Height of the housing	90 mm	90 mm
Depth of the housing	55 mm	55 mm
Installation width	54 mm	72 mm
Installation height	130 mm	130 mm
Weight, approx.	0.17 kg	0.25 kg
Product feature of the housing housing for side-by-side mounting	Yes	Yes
Type of mounting wall mounting	No	No
Type of fixing cap rail mounting	Yes	Yes
Type of mounting S7-300 rail mounting	No	No
Installation	Snaps onto DIN rail EN 60715 35x7.5/15	Snaps onto DIN rail EN 60715 35x7.5/15
Order No.		
6EP1 351-1SH03		
6EP1 352-1SH03		
Product	LOGO!Power	LOGO!Power
Power supply, type	15 V/1.9 A	15 V/4 A
Input		
Input	1-phase AC or DC	1-phase AC or DC
Rated voltage value V_{in} rated	100 ... 240 V	100 ... 240 V
Voltage range	85 ... 264 V	85 ... 264 V
Input voltage at DC	110 ... 300 V	110 ... 300 V
Overvoltage resistance	$2.3 \times V_{in}$ rated, 1.3 ms	$2.3 \times V_{in}$ rated, 1.3 ms
Mains buffering at I_{out} rated, min.	40 ms	40 ms
Mains buffering	at $V_{in} = 187$ V	at $V_{in} = 187$ V
Rated line frequency		
• 1	50 Hz	50 Hz
• 2	60 Hz	60 Hz
Rated line range	47 ... 63 Hz	47 ... 63 Hz
Input current		
• at nominal level of the input voltage 120 V nominal value	0.63 A	1.24 A
• at nominal level of the input voltage 230 V nominal value	0.33 A	0.68 A
Switch-on current limiting (+25 °C), max.	25 A	55 A
I^2t , max.	0.8 A ² ·s	3 A ² ·s
Built-in incoming fuse	internal	internal
Protection in the mains power input (IEC 898)	Recommended miniature circuit breaker: from 16 A, characteristic B or from 10 A, characteristic C	Recommended miniature circuit breaker: from 16 A, characteristic B or from 10 A, characteristic C

Technical specifications (continued)

Order No.	6EP1 351-1SH03	6EP1 352-1SH03
Product	LOGO!Power	LOGO!Power
Power supply, type	15 V/1.9 A	15 V/4 A
Output		
Output	Controlled, isolated DC voltage	Controlled, isolated DC voltage
Rated voltage Vout DC	15 V	15 V
Total tolerance, static ±	3 %	3 %
Static mains compensation, approx.	0.1 %	0.1 %
Static load balancing, approx.	1.5 %	1.5 %
Residual ripple peak-peak, max.	200 mV	200 mV
Residual ripple peak-peak, typ.	10 mV	10 mV
Spikes peak-peak, max. (bandwidth: 20 MHz)	300 mV	300 mV
Spikes peak-peak, typ. (bandwidth: 20 MHz)	30 mV	70 mV
Adjustment range	10.5 ... 16.1 V	10.5 ... 16.1 V
Product feature output voltage adjustable	Yes	Yes
Output voltage setting	via potentiometer	via potentiometer
Status display	Green LED for output voltage OK	Green LED for output voltage OK
On/off behavior	No overshoot of Vout (soft start)	No overshoot of Vout (soft start)
Startup delay, max.	0.5 s	0.5 s
Voltage rise, typ.	15 ms	15 ms
Rated current value Iout rated	1.9 A	4 A
Current range	0 ... 1.9 A	0 ... 4 A
Note	1.9 A up to +55 °C, 1.3 A up to +70 °C	4 A up to +55 °C, 2.8 A up to +70 °C
delivered active power typ.	23 W	50 W
Parallel switching for enhanced performance	Yes	Yes
Numbers of parallel switchable units for enhanced performance	2	2
Efficiency		
Efficiency at Vout rated, Iout rated, approx.	81 %	85 %
Power loss at Vout rated, Iout rated, approx.	7 W	11 W
Closed-loop control		
Dynamic mains compensation (Vin rated ±15 %), max.	0.2 %	0.2 %
Dynamic load smoothing (Iout: 10/90/10 %), Uout ± typ.	2.8 %	3 %
Load step setting time 10 to 90%, typ.	1 ms	1 ms
Load step setting time 90 to 10%, typ.	1 ms	1 ms
Protection and monitoring		
Output overvoltage protection	Yes, according to EN 60950	Yes, according to EN 60950
Current limitation, typ.	2.7 A	5.7 A
Characteristic feature of the output short-circuit protected	Yes	Yes
Short-circuit protection	Constant current characteristic	Constant current characteristic
Enduring short circuit current Effective level maximum	3.6 A	7 A
Overload/short-circuit indicator	-	-

LOGO! logic module

LOGO!Power

LOGO!Power

Technical specifications (continued)

Order No.	6EP1 351-1SH03	6EP1 352-1SH03
Product	LOGO!Power	LOGO!Power
Power supply, type	15 V/1.9 A	15 V/4 A
Safety		
Primary/secondary isolation	Yes	Yes
Potential separation	Safety extra-low output voltage U _{out} acc. to EN 60950-1 and EN 50178	Safety extra-low output voltage U _{out} acc. to EN 60950-1 and EN 50178
Protection class	Class II (without protective conductor)	Class II (without protective conductor)
CE mark	Yes	Yes
UL/CSA approval	Yes	Yes
UL/cUL (CSA) approval	cULus-listed (UL 508, CSA C22.2 No. 107.1), File E197259; cURus-recognized (UL 60950, CSA C22.2 No. 60950), File E151273	cULus-listed (UL 508, CSA C22.2 No. 107.1), File E197259; cURus-recognized (UL 60950, CSA C22.2 No. 60950), File E151273
Explosion protection	ATEX (EX) II 3G Ex nA IIC T3; cCSAus (CSA E60079, UL 60079), Class I, Div. 2, Group ABCD, T4	ATEX (EX) II 3G Ex nA IIC T3; cCSAus (CSA E60079, UL 60079), Class I, Div. 2, Group ABCD, T4
FM approval	Yes	Yes
FM approval	Class I, Div. 2, Group ABCD, T4	Class I, Div. 2, Group ABCD, T4
CB approval	Yes	Yes
Marine approval	GL, ABS	GL, ABS
Degree of protection (EN 60529)	IP20	IP20
EMC		
Emitted interference	EN 55022 Class B	EN 55022 Class B
Supply harmonics limitation	not applicable	not applicable
Noise immunity	EN 61000-6-2	EN 61000-6-2
Operating data		
Ambient temperature		
• in operation	-20 ... +70 °C	-20 ... +70 °C
- Note	with natural convection	with natural convection
• on transport	-40 ... +85 °C	-40 ... +85 °C
• in storage	-40 ... +85 °C	-40 ... +85 °C
Humidity class according to EN 60721	Climate class 3K3, no condensation	Climate class 3K3, no condensation
Mechanics		
Connection technology	screw-type terminals	screw-type terminals
Connections		
• Supply input	L, N: 1 screw terminal each for 0.5 ... 2.5 mm ² single-core/finely stranded	L, N: 1 screw terminal each for 0.5 ... 2.5 mm ² single-core/finely stranded
• Output	+, -: 2 screw terminals each for 0.5 ... 2.5 mm ²	+, -: 2 screw terminals each for 0.5 ... 2.5 mm ²
• Auxiliary	-	-
Width of the housing	54 mm	72 mm
Height of the housing	90 mm	90 mm
Depth of the housing	55 mm	55 mm
Installation width	54 mm	72 mm
Installation height	130 mm	130 mm
Weight, approx.	0.17 kg	0.25 kg
Product feature of the housing housing for side-by-side mounting	Yes	Yes
Type of mounting wall mounting	No	No
Type of fixing cap rail mounting	Yes	Yes
Type of mounting S7-300 rail mounting	No	No
Installation	Snaps onto DIN rail EN 60715 35x7.5/15	Snaps onto DIN rail EN 60715 35x7.5/15

Technical specifications (continued)

Order No.	6EP1 331-1SH03	6EP1 332-1SH43	6EP1 332-1SH52
Product	LOGO!Power	LOGO!Power	LOGO!Power
Power supply, type	24 V/1.3 A	24 V/2.5 A	24 V/4 A
Input			
Input	1-phase AC or DC	1-phase AC or DC	1-phase AC or DC
Rated voltage value V_{in} rated	100 ... 240 V	100 ... 240 V	100 ... 240 V
Voltage range	85 ... 264 V	85 ... 264 V	85 ... 264 V
Input voltage at DC	110 ... 300 V	110 ... 300 V	110 ... 300 V
Oversvoltage resistance	$2.3 \times V_{in}$ rated, 1.3 ms	$2.3 \times V_{in}$ rated, 1.3 ms	$2.3 \times V_{in}$ rated, 1.3 ms
Mains buffering at I_{out} rated, min.	0.04 s	40 ms	40 ms
Mains buffering	at $V_{in} = 187$ V	at $V_{in} = 187$ V	at $V_{in} = 187$ V
Rated line frequency			
• 1	50 Hz	50 Hz	50 Hz
• 2	60 Hz	60 Hz	60 Hz
Rated line range	47 ... 63 Hz	47 ... 63 Hz	47 ... 63 Hz
Input current			
• at nominal level of the input voltage 120 V nominal value	0.7 A	1.22 A	1.95 A
• at nominal level of the input voltage 230 V nominal value	0.35 A	0.66 A	0.97 A
Switch-on current limiting (+25 °C), max.	25 A	46 A	30 A
I^2t , max.	0.8 A ² ·s	3 A ² ·s	2.5 A ² ·s
Built-in incoming fuse	internal	internal	internal
Protection in the mains power input (IEC 898)	Recommended miniature circuit breaker: from 16 A, characteristic B or from 10 A, characteristic C	Recommended miniature circuit breaker: from 16 A, characteristic B or from 10 A, characteristic C	Recommended miniature circuit breaker: from 16 A, characteristic B or from 10 A, characteristic C
Output			
Output	Controlled, isolated DC voltage	Controlled, isolated DC voltage	Controlled, isolated DC voltage
Rated voltage V_{out} DC	24 V	24 V	24 V
Total tolerance, static \pm	3 %	3 %	3 %
Static mains compensation, approx.	0.1 %	0.1 %	0.1 %
Static load balancing, approx.	1.5 %	1.5 %	1.5 %
Residual ripple peak-peak, max.	0.2 V	200 mV	200 mV
Residual ripple peak-peak, typ.	0.01 V	10 mV	30 mV
Spikes peak-peak, max. (bandwidth: 20 MHz)	0.3 V	300 mV	300 mV
Spikes peak-peak, typ. (bandwidth: 20 MHz)	0.02 V	50 mV	60 mV
Adjustment range	22.2 ... 26.4 V	22.2 ... 26.4 V	22.2 ... 26.4 V
Product feature output voltage adjustable	Yes	Yes	Yes
Output voltage setting	via potentiometer	via potentiometer	via potentiometer
Status display	Green LED for output voltage OK	Green LED for output voltage OK	Green LED for output voltage OK
On/off behavior	No overshoot of V_{out} (soft start)	No overshoot of V_{out} (soft start)	No overshoot of V_{out} (soft start)
Startup delay, max.	0.5 s	500 ms	0.5 s
Voltage rise, typ.	0.015 s	10 ms	15 ms
Rated current value I_{out} rated	1.3 A	2.5 A	4 A
Current range	0 ... 1.3 A	0 ... 2.5 A	0 ... 4 A
Note	1.3 A up to +55 °C, 0.9 A up to +70 °C	2.5 A up to +55 °C, 1.7 A up to +70 °C	4 A up to +55 °C, 2.8 A up to +70 °C
delivered active power typ.	30 W	60 W	96 W
Parallel switching for enhanced performance	Yes	Yes	Yes
Numbers of parallel switchable units for enhanced performance	2	2	2

LOGO! logic module

LOGO!Power

LOGO!Power

Technical specifications (continued)

Order No.	6EP1 331-1SH03	6EP1 332-1SH43	6EP1 332-1SH52
Product	LOGO!Power	LOGO!Power	LOGO!Power
Power supply, type	24 V/1.3 A	24 V/2.5 A	24 V/4 A
Efficiency			
Efficiency at V_{out} rated, I_{out} rated, approx.	85 %	88 %	89 %
Power loss at V_{out} rated, I_{out} rated, approx.	6 W	8 W	12 W
Closed-loop control			
Dynamic mains compensation (V_{in} rated $\pm 15\%$), max.	0.2 %	0.2 %	0.2 %
Dynamic load smoothing (I_{out} : 10/90/10 %), $U_{out} \pm$ typ.	1 %	2 %	1.5 %
Load step setting time 10 to 90%, typ.	1 ms	1 ms	1 ms
Load step setting time 90 to 10%, typ.	1 ms	1 ms	1 ms
Protection and monitoring			
Output overvoltage protection	Yes, according to EN 60950	Yes, according to EN 60950	Yes, according to EN 60950
Current limitation, typ.	1.7 A	3.3 A	5.2 A
Characteristic feature of the output short-circuit protected	Yes	Yes	Yes
Short-circuit protection	Constant current characteristic	Constant current characteristic	Constant current characteristic
Enduring short circuit current Effective level maximum	2.4 A	4.8 A	7.9 A
Overload/short-circuit indicator	-	-	-
Safety			
Primary/secondary isolation	Yes	Yes	Yes
Potential separation	Safety extra-low output voltage U_{out} acc. to EN 60950-1 and EN 50178	Safety extra-low output voltage U_{out} acc. to EN 60950-1 and EN 50178	Safety extra-low output voltage U_{out} acc. to EN 60950-1 and EN 50178
Protection class	Class II (without protective conductor)	Class II (without protective conductor)	Class II (without protective conductor)
CE mark	Yes	Yes	Yes
UL/CSA approval	Yes	Yes	Yes
UL/cUL (CSA) approval	cULus-listed (UL 508, CSA C22.2 No. 107.1), File E197259; cURus-recognized (UL 60950, CSA C22.2 No. 60950), File E151273	cULus-listed (UL 508, CSA C22.2 No. 107.1), File E197259; cURus-recognized (UL 60950, CSA C22.2 No. 60950), File E151273	cULus-listed (UL 508, CSA C22.2 No. 107.1), File E197259; cURus-recognized (UL 60950, CSA C22.2 No. 60950), File E151273
Explosion protection	ATEX (EX) II 3G Ex nA IIC T3; cCSAus (CSA E60079, UL 60079), Class I, Div. 2, Group ABCD, T4	ATEX (EX) II 3G Ex nA IIC T3; cCSAus (CSA E60079, UL 60079), Class I, Div. 2, Group ABCD, T4	ATEX (EX) II 3G Ex nA IIC T3; cCSAus (CSA E60079, UL 60079), Class I, Div. 2, Group ABCD, T4
FM approval	Yes	Yes	Yes
FM approval	Class I, Div. 2, Group ABCD, T4	Class I, Div. 2, Group ABCD, T4	Class I, Div. 2, Group ABCD, T4
CB approval	Yes	Yes	Yes
Marine approval	GL, ABS, DNV, LRS (BV in process)	GL, ABS, DNV, LRS (BV in process)	GL, ABS, DNV, LRS (BV in process)
Degree of protection (EN 60529)	IP20	IP20	IP20
EMC			
Emitted interference	EN 55022 Class B	EN 55022 Class B	EN 55022 Class B
Supply harmonics limitation	not applicable	not applicable	EN 61000-3-2
Noise immunity	EN 61000-6-2	EN 61000-6-2	EN 61000-6-2
Operating data			
Ambient temperature			
• in operation	-20 ... +70 °C	-20 ... +70 °C	-20 ... +70 °C
- Note	with natural convection	with natural convection	with natural convection
• on transport	-40 ... +85 °C	-40 ... +85 °C	-40 ... +85 °C
• in storage	-40 ... +85 °C	-40 ... +85 °C	-40 ... +85 °C
Humidity class according to EN 60721	Climate class 3K3, no condensation	Climate class 3K3, no condensation	Climate class 3K3, no condensation

Technical specifications (continued)

Order No.	6EP1 331-1SH03	6EP1 332-1SH43	6EP1 332-1SH52
Product	LOGO!Power	LOGO!Power	LOGO!Power
Power supply, type	24 V/1.3 A	24 V/2.5 A	24 V/4 A
Mechanics			
Connection technology	screw-type terminals	screw-type terminals	screw-type terminals
Connections			
• Supply input	L, N: 1 screw terminal each for 0.5 ... 2.5 mm ² single-core/finely stranded	L, N: 1 screw terminal each for 0.5 ... 2.5 mm ² single-core/finely stranded	L, N: 1 screw terminal each for 0.5 ... 2.5 mm ² single-core/finely stranded
• Output	+, -: 2 screw terminals each for 0.5 ... 2.5 mm ²	+, -: 2 screw terminals each for 0.5 ... 2.5 mm ²	+, -: 2 screw terminals each for 0.5 ... 2.5 mm ²
• Auxiliary	-	-	-
Width of the housing	54 mm	72 mm	90 mm
Height of the housing	90 mm	90 mm	90 mm
Depth of the housing	55 mm	55 mm	55 mm
Installation width	54 mm	72 mm	90 mm
Installation height	130 mm	130 mm	130 mm
Weight, approx.	0.17 kg	0.25 kg	0.34 kg
Product feature of the housing housing for side-by-side mounting	Yes	Yes	Yes
Type of mounting wall mounting	No	No	No
Type of fixing cap rail mounting	Yes	Yes	Yes
Type of mounting S7-300 rail mounting	No	No	No
Installation	Snaps onto DIN rail EN 60715 35x7.5/15	Snaps onto DIN rail EN 60715 35x7.5/15	Snaps onto DIN rail EN 60715 35x7.5/15

Ordering data

Ordering data	Order No.	Ordering data	Order No.
LOGO!Power 5 V		LOGO!Power 15 V	
Stabilized power supply; output: 5 V DC/3 A		Stabilized power supply; output: 15 V DC/1.9 A	
• Input rated value: 100 ... 240 V AC; extended operating temperature range: up to +70 °C	6EP1 311-1SH03	• Input rated value: 100 ... 240 V AC; extended operating temperature range: up to +70 °C	6EP1 351-1SH03
Stabilized power supply; output: 5 V DC/6.3 A		Stabilized power supply; output: 15 V DC/4 A	
• Input rated value: 100 ... 240 V AC; extended operating temperature range: up to +70 °C	6EP1 311-1SH13	• Input rated value: 100 ... 240 V AC; extended operating temperature range: up to +70 °C	6EP1 352-1SH03
LOGO!Power 12 V		LOGO!Power 24 V	
Stabilized power supply; output: 12 V DC/1.9 A		Stabilized power supply; output: 24 V DC/1.3 A	
• Input rated value: 100 ... 240 V AC; extended operating temperature range: up to +70 °C	6EP1 321-1SH03	• Input rated value: 100 ... 240 V AC; extended operating temperature range: up to +70 °C	6EP1 331-1SH03
Stabilized power supply; output: 12 V DC/4.5 A		Stabilized power supply; output: 24 V DC/2.5 A	
• Input rated value: 100 ... 240 V AC; extended operating temperature range: up to +70 °C	6EP1 322-1SH03	• Input rated value: 100 ... 240 V AC; extended operating temperature range: up to +70 °C	6EP1 332-1SH43
		Stabilized power supply; output: 24 V DC/4 A	
		• Input rated value: 100 ... 240 V AC; extended operating temperature range: up to +70 °C	6EP1 332-1SH52

LOGO! logic module

LOGO!Power

LOGO!Power

More information

In addition to various power supply product lines, the perfectly coordinated complete SITOP range offers a unique range of add-on modules with which the 24 V power supply can be additionally protected against interference on the primary and secondary side – right up to all-round protection:

- Redundancy module for setting up a redundant power supply
- Uninterruptible 24 V power supplies with batteries or maintenance-free capacitors for continued operation in the event of power failure
- Selectivity modules for electronic protection of 24 V branches from overload and short-circuit

You can find more information in Catalog KT 10.1 and in the Internet at

www.siemens.com/sitop

Select the appropriate power supply quickly and easily with the SITOP Selection Tool:

www.siemens.com/sitop-selection-tool

Overview

Note:

SIPLUS extreme products are based on Siemens Industry standard products. The contents listed here were taken from the respective standard products. SIPLUS extreme-specific information was added.

SIPLUS LOGO!Power 1.3 A	
Order number	6AG1 331-1SH03-7AA0
Order number based on	6EP1 331-1SH03
Ambient temperature range	-25 °C to +70 °C
Conformal coating	Coating of the printed circuit boards and the electronic components
Technical data	The technical data of the standard product applies except for the ambient conditions.
Ambient conditions	
Relative humidity	100%, condensation/frost permissible. No commissioning if condensation present.
Biologically active substances, compliance with EN 60721-3-3	Class 3B2 mold spores, fungal spores (excluding fauna). The supplied plug covers must remain in place over the unused interfaces during operation!
Chemically active substances, compliance with EN 60721-3-3	Class 3C4 incl. salt spray in accordance with EN60068-2-52 (degree of severity 3). The supplied plug covers must remain in place over the unused interfaces during operation!
Mechanically active substances, compliance with EN 60721-3-3	Class 3S4 incl. sand, dust. The supplied plug covers must remain in place over the unused interfaces during operation!
Air pressure (depending on the highest positive temperature range specified)	1080 ... 795 hPa (-1000 ... +2000 m) see ambient temperature range 795 ... 658 hPa (+2000 ... +3500 m) derating 10 K 658 ... 540 hPa (+3500 ... +5000 m) derating 20 K

For technical documentation on SIPLUS, see:

<http://www.siemens.com/siplus-extreme>

Ordering data

Order No.

SIPLUS LOGO!Power 24 V 1.3 A

6AG1 331-1SH03-7AA0

(extended temperature range and medial exposure)

Input 100 ... 240 V AC
Output 24 V DC, 1.3 A

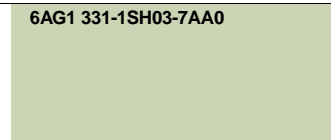

LOGO! logic module

LOGO!Contact

LOGO!Contact

Overview



- Switching module for the direct switching of resistive loads and motors

Technical specifications

	6ED1 057-4CA00-0AA0	6ED1 057-4EA00-0AA0
Weight		
Weight, approx.	160 g	160 g

Ordering data

LOGO!Contact

Switching module for direct switching of resistive loads up to 20 A and motors up to 4 kW

Switching voltage 24 V

Switching voltage 230 V

Order No.

6ED1 057-4CA00-0AA0

6ED1 057-4EA00-0AA0

Overview

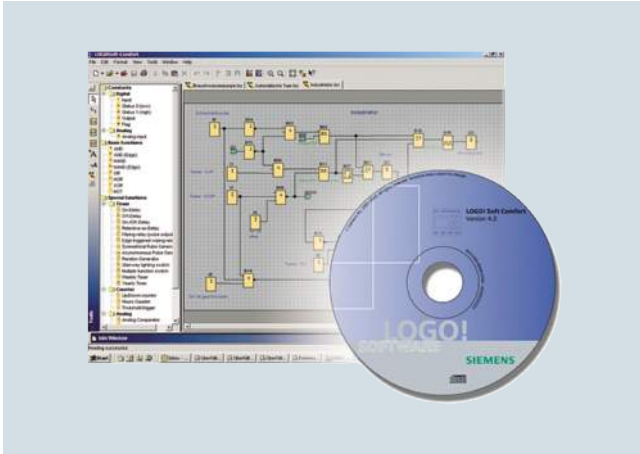

- The user-friendly software for creating control programs on a PC
- Creation of control programs in Function Block Diagram (FBD) or Ladder Diagram (LAD)
- Plus testing, simulation, online testing and archiving of control programs
- Professional documentation via numerous comment and print functions

Minimum system requirements

Windows 98 SE, NT 4.0, ME, 2000, XP (32 bit), Vista or 7 (32/64 bit)

- PC Pentium.
- 90 MB free disk capacity.
- 64 MB RAM.
- SVGA graphics card with minimum resolution 800x600 (256 colors).

Mac OS X

- Mac OS X 10.4 with J2SE 1.5.0
- Mac OS X 10.5 with J2SE 1.6.0
- PowerMac G3, G4, G4 Cube, iMac, PowerBook G3, G4 or iBook.

Linux

- Tested with SUSE Linux 10 SP2, kernel 2.6.16
- Runs on all Linux distributions on which the Java 2 SDK Version 1.3.1 runs.
- Please refer to your relevant Linux distribution for the necessary hardware requirements.

Ordering data

Order No.

LOGO!Soft Comfort V7.0

6ED1 058-0BA02-0YA1

For programming on the PC in LAD/FBD; executes on Windows 7 (32/64 bit), VISTA, XP, NT4.0, 2000, 98SE, Linux and MAC OSX; on CD-ROM

LOGO!Soft Comfort V7.0 upgrade

6ED1 058-0CA02-0YE1

Upgrade from V1.0 to V7.0

LOGO! logic module

Notes

2

SIMATIC S7-1200



3/2	Introduction	3/105	Communication
3/4	Central processing units	3/105	CM 1241 communication modules
3/4	CPU 1211C	3/107	CB 1241 communication board RS485
3/8	CPU 1212C	3/108	CM 1242-5
3/12	CPU 1214C	3/110	CM 1243-2
3/16	CPU 1215C	3/111	CM 1243-5
3/20	CPU 1217C	3/113	CSM 1277 unmanaged
3/23	SIPLUS central processing units	3/115	CP 1242-7 GPRS module
3/23	SIPLUS CPU 1211C	3/117	SIPLUS communication
3/27	SIPLUS CPU 1212C	3/117	SIPLUS CM 1241 communication modules
3/31	SIPLUS CPU 1214C	3/119	SIPLUS CM 1242-5 communication modules
3/36	SIPLUS CPU 1215C	3/120	SIPLUS CM 1243-5 communication modules
3/40	Digital modules	3/121	Power supplies
3/40	SM 1221 digital input modules	3/121	SIMATIC S7-1200 PM 1207
3/43	SB 1221 digital input modules	3/123	SIPLUS power supplies
3/46	SM 1222 digital output modules	3/123	SIPLUS PM 1207 power supplies
3/50	SB 1222 digital output modules	3/124	Operator control and monitoring
3/53	SM 1223 digital input/output modules	3/124	Basic Panels – Standard
3/58	SB 1223 digital input/output modules	3/134	SIPLUS operator control and monitoring
3/61	SIPLUS digital modules	3/134	SIPLUS Basic Panels
3/61	SIPLUS SM 1221 digital input modules	3/136	Software
3/63	SIPLUS SM 1222 digital output modules		
3/66	SIPLUS SM 1223 digital input/output modules		
3/69	SIPLUS SB 1223 digital input/output modules		
3/71	Analog modules		
3/71	SM 1231 analog input modules		
3/75	SB 1231 analog input modules		
3/77	SM 1232 analog output modules		
3/80	SB 1232 analog output modules		
3/82	SM 1234 analog input/output modules		
3/85	SM 1231 thermocouple modules		
3/88	SB 1231 thermocouple signal boards		
3/90	SM 1231 RTD signal modules		
3/93	SB 1231 RTD signal boards		
3/95	SIPLUS analog modules		
3/95	SIPLUS SM 1231 analog input modules		
3/97	SIPLUS SM 1232 analog output modules		
3/99	SIPLUS SB 1232 analog output modules		
3/101	SIPLUS SM 1234 analog input/output modules		
3/103	Special modules		
3/103	SIM 1274 simulator		
3/104	BB 1297 Battery Board		

Brochures

For brochures serving as selection guides for SIMATIC products refer to:

www.siemens.com/simatic/printmaterial

SIMATIC S7-1200

Introduction

S7-1200

Overview



- The new modular miniature controller from the SIMATIC S7 family
- Comprising:
 - Controller with integrated PROFINET IO controller interface for communication between SIMATIC controllers, HMI, programming device or other automation components
 - Communication module with PROFIBUS DP master interface
 - Communication module PROFIBUS DP slave interface
 - GPRS module for connection to GSM/G mobile phone networks
 - Integrated web server with standard and user-specific web pages
 - Data logging functionality for archiving of data at runtime from the user program
 - Powerful, integrated technology functions such as counting, measuring, closed-loop control, and motion control
 - Integrated digital and analog inputs/outputs
 - Signal boards for direct use in a controller
 - Signal modules for expansion of controllers by input/output channels
 - Communication modules for expansion of controllers with additional communications interfaces
 - Accessories, e.g. power supply, switch module or SIMATIC Memory Card
- The miniature controller that offers maximum automation at minimum cost.
- Extremely simple installation, programming and operation.
- Large-scale integration, space-saving, powerful.
- Suitable for small to medium-size automation engineering applications.
- Can be used both for simple controls and for complex automation tasks.
- All CPUs can be used in stand-alone mode, in networks and within distributed structures.
- Suitable for applications where programmable controllers would not have been economically viable in the past.
- With exceptional real-time performance and powerful communication options.

For brochures serving as selection guides for SIMATIC products refer to:

<http://www.siemens.com/simatic/printmaterial>

Technical specifications

General technical specifications SIMATIC S7-1200

Degree of protection	IP20 acc. to IEC 529
Ambient temperature	
• Operation (95% humidity)	
- Horizontal installation	-20 ... +60 °C
- Vertical installation	-20 ... +50 °C
• Transportation and storage	
- With 95% humidity	-40 ... +70 °C 25 ... 55 °C
Insulation	
• 5/24 V DC circuits	500 V AC test voltage
• 115/230 V AC circuits to ground	1500 V AC test voltage
• 115/230 V AC circuits to 115/230 V AC circuits	1500 V AC test voltage
• 230 V AC circuits to 5/24 V DC circuits	1500 V AC test voltage
• 115 V AC circuits to 5/24 V DC circuits	1500 V AC test voltage
Electromagnetic compatibility	
• Noise immunity acc. to EN 50082-2	Requirements of the EMC directive Test acc. to: IEC 801-2, IEC 801-3, IEC 801-4, EN 50141, EN 50204, IEC 801-5, VDE 0160
• Emitted interference acc. to EN 50081-1 and EN 50081-2	Test according to EN 55011, Class A, Group 1
Mechanical strength	
• Vibrations, test acc. to / tested with	IEC 68, Part 2-6: 10 ... 57 Hz; constant amplitude 0.3 mm; 58 ... 150 Hz; constant acceleration 1 g (mounted on DIN rail) or 2 g (mounted in switchboard); mode of vibration: frequency sweeps with a sweep rate of 1 octave/minute; duration of vibration: 10 frequency sweeps per axis in each direction of the three mutually perpendicular axes
• Shocks, test acc. to / tested with	IEC 68, Part 2-27/half-sine: magnitude of shock 15 g (peak value), duration 11 ms, 6 shocks in each of the three mutually perpendicular axes

General technical specifications SIPLUS S7-1200

Ambient temperature range	-40/-25/-20 ... +55/+60/+70 °C
Conformal coating	Coating of the printed circuit boards and the electronic components
Technical specifications	The technical specifications of the standard product apply except for the ambient conditions.
Ambient conditions	
Relative humidity	5 ... 100%, condensation allowed
Biologically active substances	Conformity with EN 60721-3-3, Class 3B2 mold and fungal spores (except fauna)
Chemically active substances	Compliance with EN 60721-3-3, class 3C4, incl. salt mist
Mechanically active substances	Conformity with EN 60721-3-3, Class 3S4 including sand, dust
Air pressure (depending on the highest positive temperature range specified)	1080 ... 795 hPa (-1000 ... +2000 m) see ambient temperature range 795 ... 658 hPa (+2000 ... +3500 m) derating 10 K 658 ... 540 hPa (+3500 ... +5000 m) derating 20 K

SIMATIC S7-1200

Central processing units

CPU 1211C

Overview



- The clever compact solution
- With 10 integral input/outputs
- Expandable by:
 - 1 signal board (SB) or communication board (CB)
 - Max. 3 communication modules (CM)

3

Technical specifications

	6ES7 211-1BE31-0XB0 CPU 1211C AC/DC/Relay	6ES7 211-1AE31-0XB0 CPU 1211C DC/DC/DC	6ES7 211-1HE31-0XB0 CPU 1211C DC/DC/Relay
General information			
Engineering with			
• Programming package	As of STEP 7 V11.0 SP2	As of STEP 7 V11.0 SP2	As of STEP 7 V11.0 SP2
Supply voltage			
24 V DC		Yes	Yes
120 V AC	Yes		
230 V AC	Yes		
Encoder supply			
24 V encoder supply			
• 24 V	Permissible range: 20.4 to 28.8 V	Permissible range: 20.4 to 28.8 V	Permissible range: 20.4 to 28.8 V
Power losses			
Power loss, typ.	10 W	8 W	8 W
Memory			
Work memory			
• integrated	30 kbyte	30 kbyte	30 kbyte
Load memory			
• integrated	1 Mbyte	1 Mbyte	1 Mbyte
Backup			
• without battery	Yes	Yes	Yes
CPU processing times			
for bit operations, typ.	0.085 µs; / instruction	0.085 µs; / instruction	0.085 µs; / instruction
for word operations, typ.	1.7 µs; / instruction	1.7 µs; / instruction	1.7 µs; / instruction
for floating point arithmetic, typ.	2.5 µs; / instruction	2.5 µs; / instruction	2.5 µs; / instruction
Data areas and their retentivity			
Flag			
• Number, max.	4 kbyte; Size of bit memory address area	4 kbyte; Size of bit memory address area	4 kbyte; Size of bit memory address area
Address area			
Process image			
• Inputs, adjustable	1 kbyte	1 kbyte	1 kbyte
• Outputs, adjustable	1 kbyte	1 kbyte	1 kbyte
Time of day			
Clock			
• Hardware clock (real-time clock)	Yes	Yes	Yes

Technical specifications (continued)

	6ES7 211-1BE31-0XB0 CPU 1211C AC/DC/Relay	6ES7 211-1AE31-0XB0 CPU 1211C DC/DC/DC	6ES7 211-1HE31-0XB0 CPU 1211C DC/DC/Relay
Digital inputs			
Number/binary inputs • of which, inputs usable for technological functions	6; integrated 3; HSC (High Speed Counting)	6; integrated 3; HSC (High Speed Counting)	6; integrated 3; HSC (High Speed Counting)
Digital outputs			
Number/binary outputs • of which high-speed outputs	4; Relay	4 4; 100 kHz Pulse Train Output	4; Relay
Analog inputs			
Integrated channels (AI)	2; 0 to 10 V	2; 0 to 10 V	2; 0 to 10 V
Input ranges • Voltage	Yes	Yes	Yes
1st interface			
Type of interface	PROFINET	PROFINET	PROFINET
Physics	Ethernet	Ethernet	Ethernet
Functionality • PROFINET IO Controller	Yes	Yes	Yes
Communication functions			
S7 communication • supported	Yes	Yes	Yes
Open IE communication • TCP/IP • ISO-on-TCP (RFC1006) • UDP	Yes Yes Yes	Yes Yes Yes	Yes Yes Yes
Web server • supported	Yes	Yes	Yes
Integrated Functions			
Number of counters	3	3	3
Counter frequency (counter) max.	100 kHz	100 kHz	100 kHz
Frequency meter	Yes	Yes	Yes
controlled positioning	Yes	Yes	Yes
PID controller	Yes	Yes	Yes
Number of alarm inputs	4	4	4
Number of pulse outputs		4	
Limit frequency (pulse)		100 kHz	
Ambient conditions			
Operating temperature • Min. • max.	-20 °C 60 °C	-20 °C 60 °C	-20 °C 60 °C
Configuration			
programming • Programming language - LAD - FBD - SCL	Yes Yes Yes	Yes Yes Yes	Yes Yes Yes
Dimensions			
Width	90 mm	90 mm	90 mm
Height	100 mm	100 mm	100 mm
Depth	75 mm	75 mm	75 mm
Weight			
Weight, approx.	420 g	370 g	380 g

SIMATIC S7-1200

Central processing units

CPU 1211C

3

Ordering data	Order No.	Order No.	
CPU 1211C Compact CPU, AC/DC/relay; integral program/data memory 25 KB, load memory 1 MB; wide-range power supply 85 ... 264 V AC; Boolean execution times 0.1 μs per operation; 6 digital inputs, 4 digital outputs (relays), 2 analog inputs; expandable by up to 3 communication modules and 1 signal board/communication board; digital inputs can be used as HSC at 100 kHz	6ES7 211-1BE31-0XB0	SB 1231 signal board 1 analog input, ±10 V with 12 bits or 0 ... 20 mA with 11 bits	6ES7 231-4HA30-0XB0
Compact CPU, DC/DC/DC; integrated program/data memory 25 KB, load memory 1 MB; power supply 24 V DC; Boolean execution times 0.1 μs per operation; 6 digital inputs, 4 digital outputs, 2 analog inputs; expandable by up to 3 communication modules and 1 signal board/communication board; digital inputs can be used as HSC at 100 kHz, 24 V DC digital outputs can be used as pulse outputs (PTO) or pulse- width modulated outputs (PWM) at 100 kHz	6ES7 211-1AE31-0XB0	SB 1231 thermocouple signal board 1 input +/- 80 mV, resolution 15 bits + sign, thermocouples type J, K	6ES7 231-5QA30-0XB0
Compact CPU, DC/DC/relay; integrated program/data memory 25 KB, load memory 1 MB; power supply 24 V DC; Boolean execution times 0.1 μs per operation; 6 digital inputs, 4 digital outputs (relays), 2 analog inputs; expandable by up to 3 communication modules and 1 signal board/communication board; digital inputs can be used as HSC at 100 kHz	6ES7 211-1HE31-0XB0	SB 1231 RTD signal board 1 input for resistance temperature sensors Pt 100, Pt 200, Pt 500, Pt 1000, resolution 15 bits + sign	6ES7 231-5PA30-0XB0
SB 1221 signal board 4 inputs, 5 V DC, 200 kHz 4 inputs, 24 V DC, 200 kHz	6ES7 221-3AD30-0XB0 6ES7 221-3BD30-0XB0	SB 1232 signal board 1 analog output, ±10 V with 12 bits or 0 to 20 mA with 11 bits	6ES7 232-4HA30-0XB0
SB 1222 signal board 4 outputs, 5 V DC, 0.1 A, 200 kHz 4 outputs, 24 V DC, 0.1 A, 200 kHz	6ES7 222-1AD30-0XB0 6ES7 222-1BD30-0XB0	CB 1241 RS485 communication board for point-to-point connection, with 1 RS485 interface	6ES7 241-1CH30-1XB0
SB 1223 signal board 2 inputs, 24 V DC, IEC type 1 current sinking; 2 x 24 V DC transistor outputs, 0.5 A, 5 W; can be used as HSC at up to 30 kHz 2 inputs, 5 V DC, 200 kHz 2 outputs 5 V DC, 0.1 A, 200 kHz 2 inputs, 24 V DC, 200 kHz 2 outputs 24 V DC, 0.1 A, 200 kHz	6ES7 223-0BD30-0XB0 6ES7 223-3AD30-0XB0 6ES7 223-3BD30-0XB0	Simulator (optional) 8 input switches, for CPU 1211C / CPU 1212C	6ES7 274-1XF30-0XA0
		SIMATIC Memory Card (optional) 4 MB 12 MB 24 MB	6ES7 954 -8LC01-0AA0 6ES7 954 -8LE01-0AA0 6ES7 954 -8LF01-0AA0
		Terminal block (spare part) for CPU 1211C/1212C For DI, with 14 screws, tin-plated; 4 units For DO, with 8 screws, tin-plated; 4 units For AI, with 3 screws, tin-plated; 4 units	6ES7 292-1AH30-0XA0 6ES7 292-1AP30-0XA0 6ES7 292-1BC30-0XA0
		RJ45 cable grip 4 items per pack Single port	6ES7 290-3AA30-0XA0
		Front flap set (spare part) for CPU 1211C/1212C	6ES7 291-1AA30-0XA0
		S7-1200 automation system, System Manual For SIMATIC S7-1200 and STEP 7 Basic German English French Spanish Italian Chinese	6ES7 298-8FA30-8AH0 6ES7 298-8FA30-8BH0 6ES7 298-8FA30-8CH0 6ES7 298-8FA30-8DH0 6ES7 298-8FA30-8EH0 6ES7 298-8FA30-8KH0

SIMATIC S7-1200

Central processing units

CPU 1211C

Ordering data	Order No.	Order No.
S7-1200 automation system, Easy Book Brief instructions German English French Spanish Italian Chinese	6ES7 298-8FA30-8AQ0 6ES7 298-8FA30-8BQ0 6ES7 298-8FA30-8CQ0 6ES7 298-8FA30-8DQ0 6ES7 298-8FA30-8EQ0 6ES7 298-8FA30-8KQ0	STEP 7 Professional / Basic V12 Target system: SIMATIC S7-1200, S7-1500, S7-300, S7-400, WinAC Requirement: Windows XP Home SP3 (only STEP 7 Basic), Windows XP Professional SP3 (32 bit), Windows 7 Home Premium SP1 (only STEP 7 Basic), Windows 7 Professional SP1 (32/64 bit), Windows 7 Enterprise SP1 (32/64 bit), Windows 7 Ultimate SP1 (32/64 bit), Microsoft Server 2003 R2 Std. SP2 (32 bit), Microsoft Server 2008 Std. SP2 (32/64 bit) Delivery package: German, English, Chinese, Italian, French, Spanish <hr/> STEP 7 Professional V12, Floating License
		6ES7 822-1AA02-0YA5
		STEP 7 Basic V12, Floating License
		6ES7 822-0AA02-0YA5

3

SIMATIC S7-1200

Central processing units

CPU 1212C

Overview



- The superior compact solution
- With 14 integral input/outputs
- Expandable by:
 - 1 signal board (SB) or communication board (CB)
 - 2 signal modules (SM)
 - Max. 3 communication modules (CM)

Technical specifications

	6ES7 212-1BE31-0XB0 CPU 1212C AC/DC/Relay	6ES7 212-1AE31-0XB0 CPU 1212C DC/DC/DC	6ES7 212-1HE31-0XB0 CPU 1212C AC/DC/Relay
General information			
Engineering with			
• Programming package	As of STEP 7 V11.0 SP2	As of STEP 7 V11.0 SP2	As of STEP 7 V11.0 SP2
Supply voltage			
24 V DC		Yes	Yes
120 V AC	Yes		
230 V AC	Yes		
Encoder supply			
24 V encoder supply			
• 24 V	Permissible range: 20.4 to 28.8 V	Permissible range: 20.4 to 28.8 V	Permissible range: 20.4 to 28.8 V
Power losses			
Power loss, typ.	11 W	9 W	9 W
Memory			
Work memory			
• integrated	50 kbyte	50 kbyte	50 kbyte
Load memory			
• integrated	1 Mbyte	1 Mbyte	1 Mbyte
Backup			
• without battery	Yes	Yes	Yes
CPU processing times			
for bit operations, typ.	0.085 µs; / instruction	0.085 µs; / instruction	0.085 µs; / instruction
for word operations, typ.	1.7 µs; / instruction	1.7 µs; / instruction	1.7 µs; / instruction
for floating point arithmetic, typ.	2.5 µs; / instruction	2.5 µs; / instruction	2.5 µs; / instruction
Data areas and their retentivity			
Flag			
• Number, max.	4 kbyte; Size of bit memory address area	4 kbyte; Size of bit memory address area	4 kbyte; Size of bit memory address area
Address area			
Process image			
• Inputs, adjustable	1 kbyte	1 kbyte	1 kbyte
• Outputs, adjustable	1 kbyte	1 kbyte	1 kbyte
Time of day			
Clock			
• Hardware clock (real-time clock)	Yes	Yes	Yes

Technical specifications (continued)

	6ES7 212-1BE31-0XB0 CPU 1212C AC/DC/Relay	6ES7 212-1AE31-0XB0 CPU 1212C DC/DC/DC	6ES7 212-1HE31-0XB0 CPU 1212C AC/DC/Relay
Digital inputs			
Number/binary inputs • of which, inputs usable for technological functions	8; integrated 4; HSC (High Speed Counting)	8; integrated 4; HSC (High Speed Counting)	8; integrated 4; HSC (High Speed Counting)
Digital outputs			
Number/binary outputs • of which high-speed outputs	6; Relay	6 4; 100 kHz Pulse Train Output	6; Relay
Analog inputs			
Integrated channels (AI)	2; 0 to 10 V	2; 0 to 10 V	2; 0 to 10 V
Input ranges • Voltage	Yes	Yes	Yes
1st interface			
Type of interface	PROFINET	PROFINET	PROFINET
Physics	Ethernet	Ethernet	Ethernet
Functionality • PROFINET IO Controller	Yes	Yes	Yes
Communication functions			
S7 communication • supported	Yes	Yes	Yes
Open IE communication • TCP/IP • ISO-on-TCP (RFC1006) • UDP	Yes Yes Yes	Yes Yes Yes	Yes Yes Yes
Web server • supported	Yes	Yes	Yes
Integrated Functions			
Number of counters	4	4	4
Counter frequency (counter) max.	100 kHz	100 kHz	100 kHz
Frequency meter	Yes	Yes	Yes
controlled positioning	Yes	Yes	Yes
PID controller	Yes	Yes	Yes
Number of alarm inputs	4	4	4
Number of pulse outputs		2	
Limit frequency (pulse)		100 kHz	
Ambient conditions			
Operating temperature • Min. • max.	-20 °C 60 °C	-20 °C 60 °C	-20 °C 60 °C
Configuration			
programming • Programming language - LAD - FBD - SCL	Yes Yes Yes	Yes Yes Yes	Yes Yes Yes
Dimensions			
Width	90 mm	90 mm	90 mm
Height	100 mm	100 mm	100 mm
Depth	75 mm	75 mm	75 mm
Weight			
Weight, approx.	425 g	370 g	385 g

SIMATIC S7-1200

Central processing units

CPU 1212C

3

Ordering data	Order No.	Order No.
CPU 1212C Compact CPU, AC/DC/relay; integral program/data memory 25 KB, load memory 1 MB; wide-range power supply 85 ... 264 V AC; Boolean execution times 0.1 µs per operation; 8 digital inputs, 6 digital outputs (relays), 2 analog inputs; expandable by up to 3 communication modules, 2 signal modules and 1 signal board/communication board; digital inputs can be used as HSC at 100 kHz	6ES7 212-1BE31-0XB0	SB 1223 signal board 2 inputs, 24 V DC, IEC type 1 current sinking; 2 x 24 V DC transistor outputs, 0.5 A, 5 W; can be used as HSC at up to 30 kHz 2 inputs, 5 V DC, 200 kHz 2 outputs 5 V DC, 0.1 A, 200 kHz 2 inputs, 24 V DC, 200 kHz 2 outputs 24 V DC, 0.1 A, 200 kHz
Compact CPU, DC/DC/DC; integrated program/data memory 25 KB, load memory 1 MB; power supply 24 V DC; Boolean execution times 0.1 µs per operation; 8 digital inputs, 6 digital outputs, 2 analog inputs; expandable by up to 3 communication modules, 2 signal modules, and 1 signal board/communication board; digital inputs can be used as HSC at 100 kHz, 24 V DC digital outputs can be used as pulse outputs (PTO) or pulse- width modulated outputs (PWM) at 100 kHz	6ES7 212-1AE31-0XB0	SB 1231 signal board 1 analog input, ±10 V with 12 bits or 0 ... 20 mA with 11 bits SB 1231 thermocouple signal board 1 input +/- 80 mV, resolution 15 bits + sign, thermocouples type J, K
Compact CPU, DC/DC/relay; integrated program/data memory 25 KB, load memory 2 MB; power supply 24 V DC; Boolean execution times 0.1 µs per operation; 8 digital inputs, 6 digital outputs (relays), 2 analog inputs; expandable by up to 3 communication modules, 2 signal modules, and 1 signal board/communication board; digital inputs can be used as HSC at 100 kHz	6ES7 212-1HE31-0XB0	SB 1231 RTD signal board 1 input for resistance temperature sensors Pt 100, Pt 200, Pt 500, Pt 1000, resolution 15 bits + sign SB 1232 signal board 1 analog output, ±10 V with 12 bits or 0 to 20 mA with 11 bits
SB 1221 signal board 4 inputs, 5 V DC, 200 kHz 4 inputs, 24 V DC, 200 kHz	6ES7 221-3AD30-0XB0 6ES7 221-3BD30-0XB0	CB 1241 RS485 communication board for point-to-point connection, with 1 RS485 interface Simulator (optional) 8 input switches, for CPU 1211C / CPU 1212C
SB 1222 signal board 4 outputs, 5 V DC, 0.1 A, 200 kHz 4 outputs, 24 V DC, 0.1 A, 200 kHz	6ES7 222-1AD30-0XB0 6ES7 222-1BD30-0XB0	SIMATIC Memory Card (optional) 4 MB 6ES7 954 -8LC01-0AA0 12 MB 6ES7 954 -8LE01-0AA0 24 MB 6ES7 954 -8LF01-0AA0 Extension cable for two-tier configuration for connecting digital/analog signal modules; length 2 m Starter box CPU 1212C AC/DC/relay Complete offer SIMATIC S7-1200, starter box, comprising: CPU 1212C AC/DC/relay, simulator, STEP 7 BASIC CD, manual CD, info material, in Systainer

Ordering data	Order No.	Order No.
Terminal block (spare part) for CPU 1211C/1212C for DI, with 14 screws, tin-plated; 4 units 6ES7 292-1AH30-0XA0 for DO, with 8 screws, tin-plated; 4 units 6ES7 292-1AP30-0XA0 for AI, with 3 screws, tin-plated; 4 units 6ES7 292-1BC30-0XA0		
RJ45 cable grip 4 items per pack Single port 6ES7 290-3AA30-0XA0		
Front flap set (spare part) for CPU 1211C/1212C 6ES7 291-1AA30-0XA0		
S7-1200 automation system, System Manual for SIMATIC S7-1200 and STEP 7 Basic German 6ES7 298-8FA30-8AH0 English 6ES7 298-8FA30-8BH0 French 6ES7 298-8FA30-8CH0 Spanish 6ES7 298-8FA30-8DH0 Italian 6ES7 298-8FA30-8EH0 Chinese 6ES7 298-8FA30-8KH0		
S7-1200 automation system, Easy Book Brief instructions German 6ES7 298-8FA30-8AQ0 English 6ES7 298-8FA30-8BQ0 French 6ES7 298-8FA30-8CQ0 Spanish 6ES7 298-8FA30-8DQ0 Italian 6ES7 298-8FA30-8EQ0 Chinese 6ES7 298-8FA30-8KQ0		
		STEP 7 Professional / Basic V12 Target system: SIMATIC S7-1200, S7-1500, S7-300, S7-400, WinAC Requirement: Windows XP Home SP3 (only STEP 7 Basic), Windows XP Professional SP3 (32 bit), Windows 7 Home Premium SP1 (only STEP 7 Basic), Windows 7 Professional SP1 (32/64 bit), Windows 7 Enterprise SP1 (32/64 bit), Windows 7 Ultimate SP1 (32/64 bit), Microsoft Server 2003 R2 Std. SP2 (32 bit), Microsoft Server 2008 Std. SP2 (32/64 bit) Delivery package: German, English, Chinese, Italian, French, Spanish STEP 7 Professional V12, Floating License 6ES7 822-1AA02-0YA5 STEP 7 Basic V12, Floating License 6ES7 822-0AA02-0YA5

SIMATIC S7-1200

Central processing units

CPU 1214C

Overview



- The compact high-performance CPU
- With 24 integral input/outputs
- Expandable by:
 - 1 signal board (SB) or communication board (CB)
 - 8 signal modules (SM)
 - Max. 3 communication modules (CM)

Technical specifications

	6ES7 214-1BG31-0XB0 CPU 1214C AC/DC/Relay	6ES7 214-1AG31-0XB0 CPU 1214C DC/DC/DC	6ES7 214-1HG31-0XB0 CPU 1214C DC/DC/Relay
General information			
Engineering with			
• Programming package	As of STEP 7 V11.0 SP2	As of STEP 7 V11.0 SP2	As of STEP 7 V11.0 SP2
Supply voltage			
24 V DC		Yes	Yes
120 V AC	Yes		
230 V AC	Yes		
Encoder supply			
24 V encoder supply			
• 24 V	Permissible range: 20.4 to 28.8 V	Permissible range: 20.4 to 28.8 V	Permissible range: 20.4 to 28.8 V
Power losses			
Power loss, typ.	14 W	12 W	12 W
Memory			
Work memory			
• integrated	75 kbyte	75 kbyte	75 kbyte
Load memory			
• integrated	4 Mbyte	4 Mbyte	4 Mbyte
Backup			
• without battery	Yes	Yes	Yes
CPU processing times			
for bit operations, typ.	0.085 µs; / instruction	0.085 µs; / instruction	0.085 µs; / instruction
for word operations, typ.	1.7 µs; / instruction	1.7 µs; / instruction	1.7 µs; / instruction
for floating point arithmetic, typ.	2.5 µs; / instruction	2.5 µs; / instruction	2.5 µs; / instruction
Data areas and their retentivity			
Flag			
• Number, max.	8 kbyte; Size of bit memory address area	8 kbyte; Size of bit memory address area	8 kbyte; Size of bit memory address area
Address area			
Process image			
• Inputs, adjustable	1 kbyte	1 kbyte	1 kbyte
• Outputs, adjustable	1 kbyte	1 kbyte	1 kbyte
Time of day			
Clock			
• Hardware clock (real-time clock)	Yes	Yes	Yes

Technical specifications (continued)

	6ES7 214-1BG31-0XB0 CPU 1214C AC/DC/Relay	6ES7 214-1AG31-0XB0 CPU 1214C DC/DC/DC	6ES7 214-1HG31-0XB0 CPU 1214C DC/DC/Relay
Digital inputs			
Number/binary inputs • of which, inputs usable for technological functions	14; integrated 6; HSC (High Speed Counting)	14; integrated 6; HSC (High Speed Counting)	14; integrated 6; HSC (High Speed Counting)
Digital outputs			
Number/binary outputs • of which high-speed outputs	10; Relay	10 4; 100 kHz Pulse Train Output	10; Relay
Analog inputs			
Integrated channels (AI)	2; 0 to 10 V	2; 0 to 10 V	2; 0 to 10 V
Input ranges • Voltage	Yes	Yes	Yes
1st interface			
Type of interface	PROFINET	PROFINET	PROFINET
Physics	Ethernet	Ethernet	Ethernet
Functionality • PROFINET IO Controller	Yes	Yes	Yes
Communication functions			
S7 communication • supported	Yes	Yes	Yes
Open IE communication • TCP/IP • ISO-on-TCP (RFC1006) • UDP	Yes Yes Yes	Yes Yes Yes	Yes Yes Yes
Web server • supported	Yes	Yes	Yes
Integrated Functions			
Number of counters	6	6	6
Counter frequency (counter) max.	100 kHz	100 kHz	100 kHz
Frequency meter	Yes	Yes	Yes
controlled positioning	Yes	Yes	Yes
PID controller	Yes	Yes	Yes
Number of alarm inputs	4	4	4
Number of pulse outputs		2	
Limit frequency (pulse)		100 kHz	
Ambient conditions			
Operating temperature • Min. • max.	-20 °C 60 °C	-20 °C 60 °C	-20 °C 60 °C
Configuration			
programming • Programming language - LAD - FBD - SCL	Yes Yes Yes	Yes Yes Yes	Yes Yes Yes
Dimensions			
Width	110 mm	110 mm	110 mm
Height	100 mm	100 mm	100 mm
Depth	75 mm	75 mm	75 mm
Weight			
Weight, approx.	455 g	415 g	435 g

SIMATIC S7-1200

Central processing units

CPU 1214C

3

Ordering data	Order No.	Order No.
CPU 1214C Compact CPU, AC/DC/relay; integral program/data memory 50 KB, load memory 2 MB; wide-range power supply 85 ... 264 V AC; Boolean execution times 0.1 μs per operation; 14 digital inputs, 10 digital outputs (relays), 2 analog inputs; expandable by up to 3 communication modules, 8 signal modules and 1 signal board/communication board; digital inputs can be used as HSC at 100 kHz	6ES7 214-1BG31-0XB0	SB 1223 signal board 2 inputs, 24 V DC, IEC type 1 current sinking; 2 x 24 V DC transistor outputs 0.5 A, 5 W; can be used as HSC at up to 30 kHz 2 inputs, 5 V DC, 200 kHz 2 outputs 5 V DC, 0.1 A, 200 kHz 2 inputs, 24 V DC, 200 kHz 2 outputs 24 V DC, 0.1 A, 200 kHz
Compact CPU, DC/DC/DC; integrated program/data memory 50 KB, load memory 2 MB; power supply 24 V DC; Boolean execution times 0.1 μs per operation; 14 digital inputs, 10 digital outputs, 2 analog inputs; expandable by up to 3 communication modules, 8 signal modules, and 1 signal board/communication board; digital inputs can be used as HSC at 100 kHz, 24 V DC digital outputs can be used as pulse outputs (PTO) or pulse- width modulated outputs (PWM) at 100 kHz	6ES7 214-1AG31-0XB0	SB 1231 signal board 1 analog input, ±10 V with 12 bits or 0 ... 20 mA with 11 bits SB 1231 thermocouple signal board 1 input +/- 80 mV, resolution 15 bits + sign, thermocouples type J, K
Compact CPU, DC/DC/relay; integrated program/data memory 50 KB, load memory 2 MB; power supply 24 V DC; Boolean execution times 0.1 μs per operation; 14 digital inputs, 10 digital outputs (relays), 2 analog inputs; expandable by up to 3 communication modules, 8 signal modules, and 1 signal board/communication board; digital inputs can be used as HSC at 100 kHz, 24 V DC digital outputs can be used as pulse outputs (PTO) or pulse- width modulated outputs (PWM) at 100 kHz	6ES7 214-1HG31-0XB0	SB 1231 RTD signal board 1 input for resistance temperature sensors Pt 100, Pt 200, Pt 500, Pt 1000, resolution 15 bits + sign SB 1232 signal board 1 analog output, ±10 V with 12 bits or 0 to 20 mA with 11 bits
SB 1221 signal board 4 inputs, 5 V DC, 200 kHz 4 inputs, 24 V DC, 200 kHz	6ES7 221-3AD30-0XB0 6ES7 221-3BD30-0XB0	CB 1241 RS485 communication board for point-to-point connection, with 1 RS485 interface Simulator (optional) 14 input switches, for CPU 1214C
SB 1222 signal board 4 outputs, 5 V DC, 0.1 A, 200 kHz 4 outputs, 24 V DC, 0.1 A, 200 kHz	6ES7 222-1AD30-0XB0 6ES7 222-1BD30-0XB0	6ES7 231-4HA30-0XB0 6ES7 231-5QA30-0XB0 6ES7 231-5PA30-0XB0 6ES7 232-4HA30-0XB0 6ES7 241-1CH30-1XB0
		6ES7 274-1XH30-0XA0 SIMATIC Memory Card (optional) 4 MB 12 MB 24 MB Extension cable for two-tier configuration for connecting digital/analog signal modules; length 2 m Terminal block (spare part) for CPU 1214C for DI, with 20 screws, tin-plated; 4 units for DO, with 12 screws, tin-plated; 4 units for AI, with 3 screws, tin-plated; 4 units
		6ES7 954 -8LC01-0AA0 6ES7 954 -8LE01-0AA0 6ES7 954 -8LF01-0AA0 6ES7 290-6AA30-0XA0 6ES7 292-1AV30-0XA0 6ES7 292-1AM30-0XA0 6ES7 292-1BC30-0XA0

Ordering data	Order No.	Order No.
RJ45 cable grip 4 items per pack Single port	6ES7 290-3AA30-0XA0	STEP 7 Professional / Basic V12 Target system: SIMATIC S7-1200, S7-1500, S7-300, S7-400, WinAC Requirement: Windows XP Home SP3 (only STEP 7 Basic), Windows XP Professional SP3 (32 bit), Windows 7 Home Premium SP1 (only STEP 7 Basic), Windows 7 Professional SP1 (32/64 bit), Windows 7 Enterprise SP1 (32/64 bit), Windows 7 Ultimate SP1 (32/64 bit), Microsoft Server 2003 R2 Std. SP2 (32 bit), Microsoft Server 2008 Std. SP2 (32/64 bit) Delivery package: German, English, Chinese, Italian, French, Spanish
Front flap set (spare part) for CPU 1214C	6ES7 291-1AB30-0XA0	
S7-1200 automation system, System Manual for SIMATIC S7-1200 and STEP 7 Basic German English French Spanish Italian Chinese	6ES7 298-8FA30-8AH0 6ES7 298-8FA30-8BH0 6ES7 298-8FA30-8CH0 6ES7 298-8FA30-8DH0 6ES7 298-8FA30-8EH0 6ES7 298-8FA30-8KH0	
S7-1200 automation system, Easy Book Brief instructions German English French Spanish Italian Chinese	6ES7 298-8FA30-8AQ0 6ES7 298-8FA30-8BQ0 6ES7 298-8FA30-8CQ0 6ES7 298-8FA30-8DQ0 6ES7 298-8FA30-8EQ0 6ES7 298-8FA30-8KQ0	6ES7 822-1AA02-0YA5 6ES7 822-0AA02-0YA5

SIMATIC S7-1200

Central processing units

CPU 1215C

Overview



- The compact high-performance CPU
- With 24 integral input/outputs
- Expandable by:
 - 1 signal board (SB) or communication board (CB)
 - 8 signal modules (SM)
 - Max. 3 communication modules (CM)

Technical specifications

	6ES7 215-1BG31-0XB0 CPU 1215C AC/DC/Relay	6ES7 215-1AG31-0XB0 CPU 1215C DC/DC/DC	6ES7 215-1HG31-0XB0 CPU 1215C DC/DC/Relay
General information			
Engineering with			
• Programming package	As of STEP 7 V11.0 SP2	As of STEP 7 V11.0 SP2	As of STEP 7 V11.0 SP2
Supply voltage			
24 V DC		Yes	Yes
120 V AC	Yes		
230 V AC	Yes		
Power losses			
Power loss, typ.	12 W	12 W	12 W
Memory			
Work memory			
• integrated	100 kbyte	100 kbyte	100 kbyte
Load memory			
• integrated	4 Mbyte	4 Mbyte	4 Mbyte
Backup			
• without battery	Yes	Yes	Yes
CPU processing times			
for bit operations, typ.	0.085 µs; / instruction	0.085 µs; / instruction	0.085 µs; / instruction
for word operations, typ.	1.7 µs; / instruction	1.7 µs; / instruction	1.7 µs; / instruction
for floating point arithmetic, typ.	2.5 µs; / instruction	2.5 µs; / instruction	2.5 µs; / instruction
Data areas and their retentivity			
Flag			
• Number, max.	8 kbyte; Size of bit memory address area	8 kbyte; Size of bit memory address area	8 kbyte; Size of bit memory address area
Address area			
Process image			
• Inputs, adjustable	1 kbyte	1 kbyte	1 kbyte
• Outputs, adjustable	1 kbyte	1 kbyte	1 kbyte
Time of day			
Clock			
• Hardware clock (real-time clock)	Yes	Yes	Yes

Technical specifications (continued)

	6ES7 215-1BG31-0XB0 CPU 1215C AC/DC/Relay	6ES7 215-1AG31-0XB0 CPU 1215C DC/DC/DC	6ES7 215-1HG31-0XB0 CPU 1215C DC/DC/Relay
Digital inputs			
Number/binary inputs	14; integrated	14; integrated	14; integrated
• of which, inputs usable for technological functions	6; HSC (High Speed Counting)	6; HSC (High Speed Counting)	6; HSC (High Speed Counting)
Digital outputs			
Number/binary outputs	10; Relay	10	10; Relay
• of which high-speed outputs		4; 100 kHz Pulse Train Output	
Analog inputs			
Integrated channels (AI)	2; 0 to 10 V	2; 0 to 10 V	2; 0 to 10 V
Input ranges			
• Voltage	Yes	Yes	Yes
Analog outputs			
Integrated channels (AO)	2; 0 to 20mA	2; 0 to 20mA	2; 0 to 20mA
1st interface			
Type of interface	PROFINET	PROFINET	PROFINET
Physics	Ethernet	Ethernet	Ethernet
Functionality			
• PROFINET IO Controller	Yes	Yes	Yes
Communication functions			
S7 communication			
• supported	Yes	Yes	Yes
Open IE communication			
• TCP/IP	Yes	Yes	Yes
• ISO-on-TCP (RFC1006)	Yes	Yes	Yes
• UDP	Yes	Yes	Yes
Web server			
• supported	Yes	Yes	Yes
Integrated Functions			
Number of counters	6	6	6
Counter frequency (counter) max.	100 kHz	100 kHz	100 kHz
Frequency meter	Yes	Yes	Yes
controlled positioning	Yes	Yes	Yes
PID controller	Yes	Yes	Yes
Number of alarm inputs	4	4	4
Number of pulse outputs	4	4	4
Ambient conditions			
Operating temperature			
• Min.	-20 °C	-20 °C	-20 °C
• max.	60 °C	60 °C	60 °C
Configuration			
programming			
• Programming language			
- LAD	Yes	Yes	Yes
- FBD	Yes	Yes	Yes
- SCL	Yes	Yes	Yes
Dimensions			
Width	130 mm	130 mm	130 mm
Height	100 mm	100 mm	100 mm
Depth	75 mm	75 mm	75 mm
Weight			
Weight, approx.	550 g	520 g	585 g

SIMATIC S7-1200

Central processing units

CPU 1215C

3

Ordering data	Order No.	Order No.
CPU 1215C Compact CPU, AC/DC/relay; integral program/data memory 100 KB, load memory 4 MB; wide-range power supply 85 ... 264 V AC; Boolean execution times 0.085 µs per operation; 14 digital inputs, 10 digital outputs (relays), 2 analog inputs, 2 analog outputs; expandable by up to 3 communication modules, 8 signal modules and 1 signal board/communication board; digital inputs can be used as HSC at 100 kHz	6ES7 215-1BG31-0XB0	SB 1223 signal board 2 inputs, 24 V DC, IEC type 1 current sinking; 2 x 24 V DC transistor outputs, 0.5 A, 5 W; can be used as HSC at up to 30 kHz 2 inputs, 5 V DC, 200 kHz 2 outputs 5 V DC, 0.1 A, 200 kHz 2 inputs, 24 V DC, 200 kHz 2 outputs 24 V DC, 0.1 A, 200 kHz
Compact CPU, DC/DC/DC; integrated program/data memory 100 KB, load memory 4 MB; power supply 24 V DC; Boolean execution times 0.085 µs per operation; 14 digital inputs, 10 digital outputs, 2 analog inputs, 2 analog outputs; expandable by up to 3 communication modules, 8 signal modules, and 1 signal board/communication board; digital inputs can be used as HSC at 100 kHz, 24 V DC digital outputs can be used as pulse outputs (PTO) or pulse- width modulated outputs (PWM) at 100 kHz	6ES7 215-1AG31-0XB0	SB 1231 signal board 1 analog input, ±10 V with 12 bits or 0 ... 20 mA with 11 bits SB 1231 thermocouple signal board 1 input +/- 80 mV, resolution 15 bits + sign, thermocouples type J, K SB 1231 RTD signal board 1 input for resistance temperature sensors Pt 100, Pt 200, Pt 500, Pt 1000, resolution 15 bits + sign
Compact CPU, DC/DC/relay; integrated program/data memory 100 KB, load memory 4 MB; power supply 24 V DC; Boolean execution times 0.085 µs per operation; 14 digital inputs, 10 digital outputs (relays), 2 analog inputs, 2 analog outputs; expandable by up to 3 communication modules, 8 signal modules, and 1 signal board/communication board; digital inputs can be used as HSC at 100 kHz	6ES7 215-1HG31-0XB0	SB 1232 signal board 1 analog output, ±10 V with 12 bits or 0 to 20 mA with 11 bits CB 1241 RS485 communication board for point-to-point connection, with 1 RS485 interface BB 1297 battery board for long-term backup of real-time clock; can be plugged into the sig- nal board slot of an S7-1200 CPU in FW version 3.0 or higher; battery (CR 1025) is not included
SB 1221 signal board 4 inputs, 5 V DC, 200 kHz 4 inputs, 24 V DC, 200 kHz	6ES7 221-3AD30-0XB0 6ES7 221-3BD30-0XB0	Simulator (optional) 14 input switches 6ES7 274-1XH30-0XA0
SB 1222 signal board 4 outputs, 5 V DC, 0.1 A, 200 kHz 4 outputs, 24 V DC, 0.1 A, 200 kHz	6ES7 222-1AD30-0XB0 6ES7 222-1BD30-0XB0	SIMATIC Memory Card (optional) 4 MB 6ES7 954 -8LC01-0AA0 12 MB 6ES7 954 -8LE01-0AA0 24 MB 6ES7 954 -8LF01-0AA0 Extension cable for two-tier configuration for connecting digital/analog signal modules; length 2 m 6ES7 290-6AA30-0XA0

Ordering data	Order No.	Order No.
Terminal block (spare part) for CPU 1215C for DI, with 20 screws, tin-plated; 4 units for DO, with 12 screws, tin-plated; 4 units for analog units, with 6 screws, gold-plated; 4 units	6ES7 292-1AV30-0XA0 6ES7 292-1AM30-0XA0 6ES7 292-1BF30-0XB0	STEP 7 Professional / Basic V12 Target system: SIMATIC S7-1200, S7-1500, S7-300, S7-400, WinAC Requirement: Windows XP Home SP3 (only STEP 7 Basic), Windows XP Professional SP3 (32 bit), Windows 7 Home Premium SP1 (only STEP 7 Basic), Windows 7 Professional SP1 (32/64 bit), Windows 7 Enterprise SP1 (32/64 bit), Windows 7 Ultimate SP1 (32/64 bit), Microsoft Server 2003 R2 Std. SP2 (32 bit), Microsoft Server 2008 Std. SP2 (32/64 bit) Delivery package: German, English, Chinese, Italian, French, Spanish
Front flap set (spare part) for CPU 1215C	6ES7 291-1AC30-0XA0	
RJ45 cable grip 4 items per pack Dual port	6ES7 290-3AB30-0XA0	
S7-1200 automation system, System Manual for SIMATIC S7-1200 and STEP 7 Basic		
German	6ES7 298-8FA30-8AH0	
English	6ES7 298-8FA30-8BH0	
French	6ES7 298-8FA30-8CH0	
Spanish	6ES7 298-8FA30-8DH0	
Italian	6ES7 298-8FA30-8EH0	
Chinese	6ES7 298-8FA30-8KH0	
S7-1200 automation system, Easy Book Brief instructions		
German	6ES7 298-8FA30-8AQ0	
English	6ES7 298-8FA30-8BQ0	
French	6ES7 298-8FA30-8CQ0	
Spanish	6ES7 298-8FA30-8DQ0	
Italian	6ES7 298-8FA30-8EQ0	
Chinese	6ES7 298-8FA30-8KQ0	
		STEP 7 Professional V12, Floating License
		6ES7 822-1AA02-0YA5
		STEP 7 Basic V12, Floating License
		6ES7 822-0AA02-0YA5

SIMATIC S7-1200

Central processing units

CPU 1217C

Overview

- The compact high-performance CPU
- With 24 integrated I/Os
- Expandable by:
 - 1 Signal Board (SB) or Communication Board (CB)
 - 8 signal modules (SM)
 - Max. 3 communication modules (CM)

Technical specifications

	6ES7 217-1AG40-0XB0 CPU 1217C DC/DC/DC
Supply voltage 24 V DC	Yes
Encoder supply 24 V encoder supply • 24 V	Permissible range: 20.4 to 28.8 V
Power losses Power loss, typ.	12 W
Memory Work memory • integrated	125 kbyte
Load memory • integrated • Plug-in (SIMATIC Memory Card), max.	4 Mbyte 2 Gbyte; with SIMATIC memory card
Backup • without battery	Yes
CPU processing times for bit operations, typ.	0.085 µs; / Operation
for word operations, typ.	1.5 µs; / Operation
for floating point arithmetic, typ.	2.5 µs; / Operation
Data areas and their retentivity Flag • Number, max.	8 kbyte; Size of bit memory address area
Address area I/O address area • Inputs • Outputs	1 024 byte 1 024 byte
Process image • Inputs, adjustable • Outputs, adjustable	1 kbyte 1 kbyte
Time of day Clock • Hardware clock (real-time clock)	Yes
Digital inputs Number/binary inputs • of which, inputs usable for technological functions	14; integrated 6; HSC (High Speed Counting)
Digital outputs Number/binary outputs • of which high-speed outputs	10 4
Analog inputs Integrated channels (AI)	2
Input ranges • Voltage	Yes
Analog outputs Integrated channels (AO)	2
Output ranges, current • 0 to 20 mA	Yes

	6ES7 217-1AG40-0XB0 CPU 1217C DC/DC/DC
1st interface Type of interface	PROFINET
Physics	Ethernet
Functionality • PROFINET IO Device • PROFINET IO Controller	Yes Yes
Communication functions S7 communication • supported	Yes
Open IE communication • TCP/IP • ISO-on-TCP (RFC1006) • UDP	Yes Yes Yes
Web server • supported	Yes
Number of connections • overall	16; dynamically
Integrated Functions Number of counters	6
Counter frequency (counter) max.	1 MHz
Frequency meter	Yes
controlled positioning	Yes
PID controller	Yes
Number of alarm inputs	4
Number of pulse outputs	4
Ambient conditions Operating temperature • Min. • max.	-20 °C 60 °C
Configuration programming • Programming language - LAD - FBD - SCL	Yes Yes Yes
Dimensions Width	150 mm
Height	100 mm
Depth	75 mm
Weight Weight, approx.	500 g

Ordering data	Order No.	Order No.
CPU 1217C Compact CPU, DC/DC/DC; integrated program/data memory 125 KB, load memory 4 MB; power supply 24 V DC; Boolean execution times 0.085 µs per operation; 14 digital inputs (10 digital 24 V DC inputs, 4 digital 1.5 V DC differential inputs), 10 digital outputs (6 digital 24 V DC outputs, 4 digital 1.5 V DC differential outputs), 2 analog inputs, 2 analog outputs; expandable by up to 3 communication modules, 8 signal modules, and 1 Signal Board/Communication Board; digital inputs can be used as HSC at 1 MHz, 24 V DC digital outputs can be used as pulse outputs (PTO) or pulse-width modulated outputs (PWM) at 100 kHz	6ES7 217-1AG40-0XB0	
SB 1221 signal board 4 inputs, 5 V DC, 200 kHz 4 inputs, 24 V DC, 200 kHz	6ES7 221-3AD30-0XB0 6ES7 221-3BD30-0XB0	
SB 1222 signal board 4 outputs, 5 V DC, 0.1 A, 200 kHz 4 outputs, 24 V DC, 0.1 A, 200 kHz	6ES7 222-1AD30-0XB0 6ES7 222-1BD30-0XB0	
SB 1223 signal board 2 inputs, 24 V DC, IEC type 1 current sinking; 2 x 24 V DC transistor outputs, 0.5 A, 5 W; can be used as HSC at up to 30 kHz 2 inputs, 5 V DC, 200 kHz 2 outputs 5 V DC, 0.1 A, 200 kHz 2 inputs, 24 V DC, 200 kHz 2 outputs 24 V DC, 0.1 A, 200 kHz	6ES7 223-0BD30-0XB0 6ES7 223-3AD30-0XB0 6ES7 223-3BD30-0XB0	
SB 1231 signal board 1 analog input, ±10 V with 12 bits or 0 ... 20 mA with 11 bits	6ES7 231-4HA30-0XB0	
SB 1231 thermocouple signal board 1 input +/- 80 mV, resolution 15 bits + sign, thermocouples type J, K	6ES7 231-5QA30-0XB0	
		SB 1231 RTD signal board 1 input for resistance temperature sensors Pt 100, Pt 200, Pt 500, Pt 1000, resolution 15 bits + sign
		SB 1232 signal board 1 analog output, ±10 V with 12 bits or 0 to 20 mA with 11 bits
		CB 1241 RS485 communication board for point-to-point connection, with 1 RS485 interface
		BB 1297 battery board for long-term backup of real-time clock; can be plugged into the sig- nal board slot of an S7-1200 CPU in FW version 3.0 or higher; battery (CR 1025) is not included
		Simulator (optional) 14 input switches
		SIMATIC Memory Card (optional) 4 MB 12 MB 24 MB 2 GB
		Extension cable for two-tier configuration for connecting digital/analog signal modules; length 2 m
		Terminal block (spare part) for CPU 1217C for DI, with 10 screws, tin-plated; 4 units for DI, with 16 screws, tin-plated; 4 units for DO, with 18 screws, tin-plated; 4 units for analog units, with 6 screws, gold- plated; 4 units
		RJ45 cable grip 4 items per pack Dual port
		6ES7 231-5PA30-0XB0 6ES7 232-4HA30-0XB0 6ES7 241-1CH30-1XB0 6ES7 297-0AX30-0XA0 6ES7 274-1XK30-0XA0 6ES7 954 -8LC01-0AA0 6ES7 954 -8LE01-0AA0 6ES7 954 -8LF01-0AA0 6ES7 954 -8LP01-0AA0 6ES7 290-6AA30-0XA0 6ES7 292-1AK30-0XA0 6ES7 292-1AR30-0XA0 6ES7 292-1AT30-0XA0 6ES7 292-1BF30-0XB0 6ES7 290-3AB30-0XA0

SIMATIC S7-1200

Central processing units

CPU 1217C

3

Ordering data	Order No.	Order No.
S7-1200 automation system, System Manual for SIMATIC S7-1200 and STEP 7 Basic German English French Spanish Italian Chinese	6ES7 298-8FA30-8AH0 6ES7 298-8FA30-8BH0 6ES7 298-8FA30-8CH0 6ES7 298-8FA30-8DH0 6ES7 298-8FA30-8EH0 6ES7 298-8FA30-8KH0	STEP 7 Professional / Basic V12 Target system: SIMATIC S7-1200, S7-1500, S7-300, S7-400, WinAC Requirement: Windows XP Home SP3 (only STEP 7 Basic), Windows XP Professional SP3 (32 bit), Windows 7 Home Premium SP1 (only STEP 7 Basic), Windows 7 Professional SP1 (32/64 bit), Windows 7 Enterprise SP1 (32/64 bit), Windows 7 Ultimate SP1 (32/64 bit), Microsoft Server 2003 R2 Std. SP2 (32 bit), Microsoft Server 2008 Std. SP2 (32/64 bit) Delivery package: German, English, Chinese, Italian, French, Spanish
S7-1200 automation system, Easy Book Brief instructions German English French Spanish Italian Chinese	6ES7 298-8FA30-8AQ0 6ES7 298-8FA30-8BQ0 6ES7 298-8FA30-8CQ0 6ES7 298-8FA30-8DQ0 6ES7 298-8FA30-8EQ0 6ES7 298-8FA30-8KQ0	6ES7 822-1AA02-0YA5 6ES7 822-0AA02-0YA5
		STEP 7 Professional V12, Floating License STEP 7 Basic V12, Floating License

Overview



- The clever compact solution
- With 10 integrated I/Os
- Expandable with:
 - 1 signal board (SB) or communication board (CB)
 - Max. 3 communication modules (CM)

Note:

SIPLUS extreme products are based on Siemens Industry standard products. The contents listed here were taken from the respective standard products. SIPLUS extreme-specific information was added.

3

Technical specifications

The technical data correspond to those of the based-on modules apart from the values listed in the table.

	6AG1 211-1AE31-4XB0 CPU 1211C DC/DC/DC	6AG1 211-1AE31-2XB0 CPU 1211C DC/DC/DC
Based on	6ES7 211-1AE31-0XB0	6ES7 211-1AE31-0XB0
Ambient conditions		
Operating temperature		
• Min.	-20 °C; = Tmin; startup @ 0 °C	-40 °C; = Tmin; startup @ -25 °C
• max.	60 °C; = Tmax	70 °C; = Tmax; > +60 °C Number of simultaneously controllable inputs and outputs max. 50%; no signal board can be used
• horizontal installation, min.	-20 °C; = Tmin; startup @ 0 °C	-40 °C; = Tmin; startup @ -25 °C
• horizontal installation, max.	60 °C; = Tmax	70 °C; = Tmax; > +60 °C Number of simultaneously controllable inputs and outputs max. 50%; no signal board can be used
• vertical installation, min.	-20 °C; = Tmin; startup @ 0 °C	-40 °C; = Tmin; startup @ -25 °C
• vertical installation, max.	50 °C; = Tmax	50 °C; = Tmax
Storage/transport temperature		
• Min.	-40 °C	-40 °C
• max.	70 °C	70 °C
Vibrations		
• Vibrations	2G wall mounting, 1G DIN rail	2G wall mounting, 1G DIN rail
• Operation, checked according to IEC 60068-2-6	Yes	Yes
Shock test		
• checked according to IEC 60068-2-27	Yes; IEC 68, Part 2-27 half-sine: strength of the shock 15 g (peak value), duration 11 ms	Yes; IEC 68, Part 2-27 half-sine: strength of the shock 15 g (peak value), duration 11 ms
Extended ambient conditions		
• Relative to ambient temperature-atmospheric pressure-installation altitude	Tmin ... Tmax at 1080 hPa ... 795 hPa (-1000 m ... +2000 m) // Tmin ... (Tmax - 10K) at 795 hPa ... 658 hPa (+2000 m ... +3500 m) // Tmin ... (Tmax - 20K) at 658 hPa ... 540 hPa (+3500 m ... +5000 m) 0 °C	Tmin ... Tmax at 1080 hPa ... 795 hPa (-1000 m ... +2000 m) // Tmin ... (Tmax - 10K) at 795 hPa ... 658 hPa (+2000 m ... +3500 m) // Tmin ... (Tmax - 20K) at 658 hPa ... 540 hPa (+3500 m ... +5000 m) -25 °C
• at cold restart		
• Relative humidity		
- with condensation	100 %; RH incl. condensation/frost (no commissioning under condensation conditions)	100 %; RH incl. condensation/frost (no commissioning under condensation conditions)
• Resistance		
- to biologically active substances	Yes; Class 3B2 mold, fungus and dry rot spores (with the exception of fauna). The supplied connector covers must remain on the unused interfaces during operation!	Yes; Class 3B2 mold, fungus and dry rot spores (with the exception of fauna). The supplied connector covers must remain on the unused interfaces during operation!
- to chemically active substances	Yes	Yes
- to mechanically active substances	Yes; Class 3S4 incl. sand, dust. The supplied connector covers must remain on the unused interfaces during operation!	Yes; Class 3S4 incl. sand, dust. The supplied connector covers must remain on the unused interfaces during operation!

SIMATIC S7-1200

SIPLUS central processing units

SIPLUS CPU 1211C

Technical specifications (continued)

Based on	6AG1 211-1BE31-4XB0 CPU 1211C AC/DC/Relay 6ES7 211-1BE31-0XB0	6AG1 211-1BE31-2XB0 CPU 1211C AC/DC/Relay 6ES7 211-1BE31-0XB0
Ambient conditions		
Operating temperature		
• Min.	-20 °C; = Tmin; startup @ 0 °C	-40 °C; = Tmin; startup @ -25 °C
• max.	60 °C; = Tmax	70 °C; = Tmax; > +60 °C Number of simultaneously controllable inputs and outputs max. 50%; no signal board can be used
• horizontal installation, min.	-20 °C; = Tmin; startup @ 0 °C	-40 °C; = Tmin; startup @ -25 °C
• horizontal installation, max.	60 °C; = Tmax	70 °C; = Tmax; > +60 °C Number of simultaneously controllable inputs and outputs max. 50%; no signal board can be used
• vertical installation, min.	-20 °C; = Tmin; startup @ 0 °C	-40 °C; = Tmin; startup @ -25 °C
• vertical installation, max.	50 °C; = Tmax	50 °C; = Tmax
Storage/transport temperature		
• Min.	-40 °C	-40 °C
• max.	70 °C	70 °C
Vibrations		
• Vibrations	2G wall mounting, 1G DIN rail	2G wall mounting, 1G DIN rail
• Operation, checked according to IEC 60068-2-6	Yes	Yes
Shock test		
• checked according to IEC 60068-2-27	Yes; IEC 68, Part 2-27 half-sine: strength of the shock 15 g (peak value), duration 11 ms	Yes; IEC 68, Part 2-27 half-sine: strength of the shock 15 g (peak value), duration 11 ms
Extended ambient conditions		
• Relative to ambient temperature-atmospheric pressure-installation altitude	Tmin ... Tmax at 1080 hPa ... 795 hPa (-1000 m ... +2000 m) // Tmin ... (Tmax - 10K) at 795 hPa ... 658 hPa (+2000 m ... +3500 m) // Tmin ... (Tmax - 20K) at 658 hPa ... 540 hPa (+3500 m ... +5000 m)	Tmin ... Tmax at 1080 hPa ... 795 hPa (-1000 m ... +2000 m) // Tmin ... (Tmax - 10K) at 795 hPa ... 658 hPa (+2000 m ... +3500 m) // Tmin ... (Tmax - 20K) at 658 hPa ... 540 hPa (+3500 m ... +5000 m)
• at cold restart	0 °C	-25 °C
• Relative humidity		
- with condensation	100 %; RH incl. condensation/frost (no commissioning under condensation conditions)	100 %; RH incl. condensation/frost (no commissioning under condensation conditions)
• Resistance		
- to biologically active substances	Yes; Class 3B2 mold, fungus and dry rot spores (with the exception of fauna). The supplied connector covers must remain on the unused interfaces during operation!	Yes; Class 3B2 mold, fungus and dry rot spores (with the exception of fauna). The supplied connector covers must remain on the unused interfaces during operation!
- to chemically active substances	Yes	Yes
- to mechanically active substances	Yes; Class 3S4 incl. sand, dust. The supplied connector covers must remain on the unused interfaces during operation!	Yes; Class 3S4 incl. sand, dust. The supplied connector covers must remain on the unused interfaces during operation!

Technical specifications (continued)

Based on	6AG1 211-1HE31-4XB0 CPU 1211C DC/DC/Relay 6ES7 211-1HE31-0XB0	6AG1 211-1HE31-2XB0 CPU 1211C DC/DC/Relay 6ES7 211-1HE31-0XB0
Ambient conditions		
Operating temperature		
• Min.	-20 °C; = Tmin; startup @ 0 °C	-40 °C; = Tmin; startup @ -25 °C
• max.	60 °C; = Tmax	70 °C; = Tmax; > +60 °C Number of simultaneously controllable inputs and outputs max. 50%; no signal board can be used
• horizontal installation, min.	-20 °C; = Tmin; startup @ 0 °C	-40 °C; = Tmin; startup @ -25 °C
• horizontal installation, max.	60 °C; = Tmax	70 °C; = Tmax; > +60 °C Number of simultaneously controllable inputs and outputs max. 50%; no signal board can be used
• vertical installation, min.	-20 °C; = Tmin; startup @ 0 °C	-40 °C; = Tmin; startup @ -25 °C
• vertical installation, max.	50 °C; = Tmax	50 °C; = Tmax
Storage/transport temperature		
• Min.	-40 °C	-40 °C
• max.	70 °C	70 °C
Vibrations		
• Vibrations	2G wall mounting, 1G DIN rail	2G wall mounting, 1G DIN rail
• Operation, checked according to IEC 60068-2-6	Yes	Yes
Shock test		
• checked according to IEC 60068-2-27	Yes; IEC 68, Part 2-27 half-sine: strength of the shock 15 g (peak value), duration 11 ms	Yes; IEC 68, Part 2-27 half-sine: strength of the shock 15 g (peak value), duration 11 ms
Extended ambient conditions		
• Relative to ambient temperature-atmospheric pressure-installation altitude	Tmin ... Tmax at 1080 hPa ... 795 hPa (-1000 m ... +2000 m) // Tmin ... (Tmax - 10K) at 795 hPa ... 658 hPa (+2000 m ... +3500 m) // Tmin ... (Tmax - 20K) at 658 hPa ... 540 hPa (+3500 m ... +5000 m)	Tmin ... Tmax at 1080 hPa ... 795 hPa (-1000 m ... +2000 m) // Tmin ... (Tmax - 10K) at 795 hPa ... 658 hPa (+2000 m ... +3500 m) // Tmin ... (Tmax - 20K) at 658 hPa ... 540 hPa (+3500 m ... +5000 m)
• at cold restart	0 °C	-25 °C
• Relative humidity - with condensation	100 %; RH incl. condensation/frost (no commissioning under condensation conditions)	100 %; RH incl. condensation/frost (no commissioning under condensation conditions)
• Resistance - to biologically active substances	Yes; Class 3B2 mold, fungus and dry rot spores (with the exception of fauna). The supplied connector covers must remain on the unused interfaces during operation!	Yes; Class 3B2 mold, fungus and dry rot spores (with the exception of fauna). The supplied connector covers must remain on the unused interfaces during operation!
- to chemically active substances	Yes	Yes
- to mechanically active substances	Yes; Class 3S4 incl. sand, dust. The supplied connector covers must remain on the unused interfaces during operation!	Yes; Class 3S4 incl. sand, dust. The supplied connector covers must remain on the unused interfaces during operation!

SIMATIC S7-1200

SIPLUS central processing units

SIPLUS CPU 1211C

3

Ordering data

Order No.

Order No.

SIPLUS CPU 1211C compact CPU, AC/DC/relay

(extended temperature range and medial exposure)

Integrated program and data memory of 25 KB, load memory of 1 MB; wide-range alternating voltage supply 85 ... 264 V AC; Boolean execution times of 0.1 ms per operation; 6 digital inputs, 4 digital outputs (relay), 2 analog inputs; expandable with up to 3 communication modules and 1 signal board/communication board; digital inputs usable as HSC with 100 kHz

- for areas with extreme medial exposure (conformal coating); ambient temperature -20 ... +60 °C;
- for areas with extreme medial exposure (conformal coating); ambient temperature -40 ... +70 °C;

6AG1 211-1BE31-4XB0

6AG1 211-1BE31-2XB0

SIPLUS CPU 1211C compact CPU, DC/DC/relay

(extended temperature range and medial exposure)

Integrated program and data memory of 25 KB, load memory of 1 MB; power supply 24 V DC; Boolean execution times of 0.1 ms per operation; 6 digital inputs, 4 digital outputs (relay), 2 analog inputs; expandable with up to 3 communication modules and 1 signal board/communication board; digital inputs usable as HSC with 100 kHz

- for areas with extreme medial exposure (conformal coating); ambient temperature -20 ... +60 °C;
- for areas with extreme medial exposure (conformal coating); ambient temperature -40 ... +70 °C;

6AG1 211-1HE31-4XB0

6AG1 211-1HE31-2XB0

SIPLUS CPU 1211C compact CPU, DC/DC/DC

(extended temperature range and medial exposure)

Integrated program and data memory of 25 KB, load memory of 1 MB; power supply 24 V DC; Boolean execution times of 0.1 ms per operation; 6 digital inputs, 4 digital outputs, 2 analog inputs; expandable with up to 3 communication modules and 1 signal board/communication board; digital inputs usable as HSC with 100 kHz, 24 V DC digital outputs usable as pulse outputs (PTO) or pulse-width-modulated outputs (PWM) with 100 kHz

- for areas with extreme medial exposure (conformal coating); ambient temperature -20 ... +60 °C;
- for areas with extreme medial exposure (conformal coating); ambient temperature -40 ... +70 °C;

6AG1 211-1AE31-4XB0

6AG1 211-1AE31-2XB0

Accessories

SIPLUS SB 1223 digital input/output signal board

(extended temperature range and medial exposure)

2 inputs, 24 V DC, IEC type 1 current sinking; 2 transistor outputs 24 V DC, 0.5 A, 5 W; can be used as HSC at up to 30 kHz

- Suitable for areas with extraordinary medial exposure (conformal coating)
- Ambient temperature -25 ... +55 °C

6AG1 223-0BD30-4XB0

6AG1 223-0BD30-5XB0

2 inputs, 5 V DC, 200 kHz; 2 outputs 5 V DC, 0.1 A, 200 kHz

- For areas with extreme medial exposure (conformal coating), ambient temperature -25 ... +55 °C

6AG1 223-3AD30-5XB0

SIPLUS SB 1232 analog output signal board

(extended temperature range and medial exposure)

Ambient temperature range
-25 ... +55 °C

1 analog output, ±10 V with 12 bits or 0 ... 20 mA with 11 bits

Ambient temperature range
0 ... +55 °C

1 analog output, ±10 V with 12 bits or 0 ... 20 mA with 11 bits

6AG1 232-4HA30-5XB0

6AG1 232-4HA30-4XB0

Additional accessories

See SIMATIC S7-1200 CPU 1211C, page 3/6

Overview



- The superior compact solution
- With 14 integral input/outputs
- Expandable with:
 - 1 signal board (SB) or communication board (CB)
 - 2 signal modules (SM)
 - Max. 3 communication modules (CM)

Note:

SIPLUS extreme products are based on Siemens Industry standard products. The contents listed here were taken from the respective standard products. SIPLUS extreme-specific information was added.

3

Technical specifications

The technical data correspond to those of the based-on modules apart from the values listed in the table.

	6AG1 212-1AE31-4XB0 CPU 1212C DC/DC/DC	6AG1 212-1AE31-2XB0 CPU 1212C DC/DC/DC
Based on	6ES7 212-1AE31-0XB0	6ES7 212-1AE31-0XB0
Ambient conditions		
Operating temperature		
• Min.	-20 °C; = Tmin; startup @ 0 °C	-40 °C; = Tmin; startup @ -25 °C
• max.	60 °C; = Tmax	70 °C; = Tmax; > +60 °C Number of simultaneously controllable inputs and outputs max. 50%; no signal board can be used
• horizontal installation, min.	-20 °C; = Tmin; startup @ 0 °C	-40 °C; = Tmin; startup @ -25 °C
• horizontal installation, max.	60 °C; = Tmax	70 °C; = Tmax; > +60 °C Number of simultaneously controllable inputs and outputs max. 50%; no signal board can be used
• vertical installation, min.	-20 °C; = Tmin; startup @ 0 °C	-40 °C; = Tmin; startup @ -25 °C
• vertical installation, max.	50 °C; = Tmax	50 °C; = Tmax
Storage/transport temperature		
• Min.	-40 °C	-40 °C
• max.	70 °C	70 °C
Vibrations		
• Vibrations	2G wall mounting, 1G DIN rail	2G wall mounting, 1G DIN rail
• Operation, checked according to IEC 60068-2-6	Yes	Yes
Shock test		
• checked according to IEC 60068-2-27	Yes; IEC 68, Part 2-27 half-sine: strength of the shock 15 g (peak value), duration 11 ms	Yes; IEC 68, Part 2-27 half-sine: strength of the shock 15 g (peak value), duration 11 ms
Extended ambient conditions		
• Relative to ambient temperature-atmospheric pressure-installation altitude	Tmin ... Tmax at 1080 hPa ... 795 hPa (-1000 m ... +2000 m) // Tmin ... (Tmax - 10K) at 795 hPa ... 658 hPa (+2000 m ... +3500 m) // Tmin ... (Tmax - 20K) at 658 hPa ... 540 hPa (+3500 m ... +5000 m) 0 °C	Tmin ... Tmax at 1080 hPa ... 795 hPa (-1000 m ... +2000 m) // Tmin ... (Tmax - 10K) at 795 hPa ... 658 hPa (+2000 m ... +3500 m) // Tmin ... (Tmax - 20K) at 658 hPa ... 540 hPa (+3500 m ... +5000 m) -25 °C
• at cold restart		
• Relative humidity		
- with condensation	100 %; RH incl. condensation/frost (no commissioning under condensation conditions)	100 %; RH incl. condensation/frost (no commissioning under condensation conditions)
• Resistance		
- to biologically active substances	Yes; Class 3B2 mold, fungus and dry rot spores (with the exception of fauna). The supplied connector covers must remain on the unused interfaces during operation!	Yes; Class 3B2 mold, fungus and dry rot spores (with the exception of fauna). The supplied connector covers must remain on the unused interfaces during operation!
- to chemically active substances	Yes	Yes
- to mechanically active substances	Yes; Class 3S4 incl. sand, dust. The supplied connector covers must remain on the unused interfaces during operation!	Yes; Class 3S4 incl. sand, dust. The supplied connector covers must remain on the unused interfaces during operation!

SIMATIC S7-1200

SIPLUS central processing units

SIPLUS CPU 1212C

Technical specifications (continued)

Based on	6AG1 212-1BE31-4XB0 CPU 1212C AC/DC/Relay 6ES7 212-1BE31-0XB0	6AG1 212-1BE31-2XB0 CPU 1212C AC/DC/Relay 6ES7 212-1BE31-0XB0
Ambient conditions		
Operating temperature		
• Min.	-20 °C; = Tmin; startup @ 0 °C	-40 °C; = Tmin; startup @ -25 °C
• max.	60 °C; = Tmax	70 °C; = Tmax; > +60 °C Number of simultaneously controllable inputs and outputs max. 50%; no signal board can be used
• horizontal installation, min.	-20 °C; = Tmin; startup @ 0 °C	-40 °C; = Tmin; startup @ -25 °C
• horizontal installation, max.	60 °C; = Tmax	70 °C; = Tmax; > +60 °C Number of simultaneously controllable inputs and outputs max. 50%; no signal board can be used
• vertical installation, min.	-20 °C; = Tmin; startup @ 0 °C	-40 °C; = Tmin; startup @ -25 °C
• vertical installation, max.	50 °C; = Tmax	50 °C; = Tmax
Storage/transport temperature		
• Min.	-40 °C	-40 °C
• max.	70 °C	70 °C
Vibrations		
• Vibrations	2G wall mounting, 1G DIN rail	2G wall mounting, 1G DIN rail
• Operation, checked according to IEC 60068-2-6	Yes	Yes
Shock test		
• checked according to IEC 60068-2-27	Yes; IEC 68, Part 2-27 half-sine: strength of the shock 15 g (peak value), duration 11 ms	Yes; IEC 68, Part 2-27 half-sine: strength of the shock 15 g (peak value), duration 11 ms
Extended ambient conditions		
• Relative to ambient temperature-atmospheric pressure-installation altitude	Tmin ... Tmax at 1080 hPa ... 795 hPa (-1000 m ... +2000 m) // Tmin ... (Tmax - 10K) at 795 hPa ... 658 hPa (+2000 m ... +3500 m) // Tmin ... (Tmax - 20K) at 658 hPa ... 540 hPa (+3500 m ... +5000 m) 0 °C	Tmin ... Tmax at 1080 hPa ... 795 hPa (-1000 m ... +2000 m) // Tmin ... (Tmax - 10K) at 795 hPa ... 658 hPa (+2000 m ... +3500 m) // Tmin ... (Tmax - 20K) at 658 hPa ... 540 hPa (+3500 m ... +5000 m) -25 °C
• at cold restart		
• Relative humidity - with condensation	100 %; RH incl. condensation/frost (no commissioning under condensation conditions)	100 %; RH incl. condensation/frost (no commissioning under condensation conditions)
• Resistance - to biologically active substances	Yes; Class 3B2 mold, fungus and dry rot spores (with the exception of fauna). The supplied connector covers must remain on the unused interfaces during operation!	Yes; Class 3B2 mold, fungus and dry rot spores (with the exception of fauna). The supplied connector covers must remain on the unused interfaces during operation!
- to chemically active substances	Yes	Yes
- to mechanically active substances	Yes; Class 3S4 incl. sand, dust. The supplied connector covers must remain on the unused interfaces during operation!	Yes; Class 3S4 incl. sand, dust. The supplied connector covers must remain on the unused interfaces during operation!

Technical specifications (continued)

Based on	6AG1 212-1HE31-4XB0 CPU 1212C AC/DC/Relay 6ES7 212-1HE31-0XB0	6AG1 212-1HE31-2XB0 CPU 1212C AC/DC/Relay 6ES7 212-1HE31-0XB0
Ambient conditions		
Operating temperature		
• Min.	-20 °C; = Tmin; startup @ 0 °C	-40 °C; = Tmin; startup @ -25 °C
• max.	60 °C; = Tmax	70 °C; = Tmax; > +60 °C Number of simultaneously controllable inputs and outputs max. 50%; no signal board can be used
• horizontal installation, min.	-20 °C; = Tmin; startup @ 0 °C	-40 °C; = Tmin; startup @ -25 °C
• horizontal installation, max.	60 °C; = Tmax	70 °C; = Tmax; > +60 °C Number of simultaneously controllable inputs and outputs max. 50%; no signal board can be used
• vertical installation, min.	-20 °C; = Tmin; startup @ 0 °C	-40 °C; = Tmin; startup @ -25 °C
• vertical installation, max.	50 °C; = Tmax	50 °C; = Tmax
Storage/transport temperature		
• Min.	-40 °C	-40 °C
• max.	70 °C	70 °C
Vibrations		
• Vibrations	2G wall mounting, 1G DIN rail	2G wall mounting, 1G DIN rail
• Operation, checked according to IEC 60068-2-6	Yes	Yes
Shock test		
• checked according to IEC 60068-2-27	Yes; IEC 68, Part 2-27 half-sine: strength of the shock 15 g (peak value), duration 11 ms	Yes; IEC 68, Part 2-27 half-sine: strength of the shock 15 g (peak value), duration 11 ms
Extended ambient conditions		
• Relative to ambient temperature-atmospheric pressure-installation altitude	Tmin ... Tmax at 1080 hPa ... 795 hPa (-1000 m ... +2000 m) // Tmin ... (Tmax - 10K) at 795 hPa ... 658 hPa (+2000 m ... +3500 m) // Tmin ... (Tmax - 20K) at 658 hPa ... 540 hPa (+3500 m ... +5000 m)	Tmin ... Tmax at 1080 hPa ... 795 hPa (-1000 m ... +2000 m) // Tmin ... (Tmax - 10K) at 795 hPa ... 658 hPa (+2000 m ... +3500 m) // Tmin ... (Tmax - 20K) at 658 hPa ... 540 hPa (+3500 m ... +5000 m)
• at cold restart	0 °C	-25 °C
• Relative humidity - with condensation	100 %; RH incl. condensation/frost (no commissioning under condensation conditions)	100 %; RH incl. condensation/frost (no commissioning under condensation conditions)
• Resistance - to biologically active substances	Yes; Class 3B2 mold, fungus and dry rot spores (with the exception of fauna). The supplied connector covers must remain on the unused interfaces during operation!	Yes; Class 3B2 mold, fungus and dry rot spores (with the exception of fauna). The supplied connector covers must remain on the unused interfaces during operation!
- to chemically active substances	Yes	Yes
- to mechanically active substances	Yes; Class 3S4 incl. sand, dust. The supplied connector covers must remain on the unused interfaces during operation!	Yes; Class 3S4 incl. sand, dust. The supplied connector covers must remain on the unused interfaces during operation!

SIMATIC S7-1200

SIPLUS central processing units

SIPLUS CPU 1212C

3

Ordering data

Order No.

Order No.

SIPLUS CPU 1212C

compact CPU, AC/DC/relay

(extended temperature range and medial exposure)

Integrated program and data memory of 25 KB, load memory of 1 MB; wide-range alternating voltage supply 85 ... 264 V AC; Boolean execution times of 0.1 ms per operation; 8 digital inputs, 6 digital outputs (relay), 2 analog inputs; expandable with up to 3 communication modules, 2 signal modules, and 1 signal board/communication board; digital inputs usable as HSC with 100 kHz

- for areas with extreme medial exposure (conformal coating); ambient temperature -20 ... +60 °C
- for areas with extreme medial exposure (conformal coating); ambient temperature -40 ... +70 °C

6AG1 212-1BE31-4XB0

6AG1 212-1BE31-2XB0

SIPLUS CPU 1212C

compact CPU, DC/DC/DC

(extended temperature range and medial exposure)

Integrated program and data memory of 25 KB, load memory of 1 MB; power supply 24 V DC; Boolean execution times of 0.1 ms per operation; 8 digital inputs, 6 digital outputs, 2 analog inputs; expandable with up to 3 communication modules, 2 signal modules and 1 signal board/communication board; digital inputs usable as HSC with 100 kHz, 24 V DC digital outputs usable as pulse outputs (PTO) or pulse-width-modulated outputs (PWM) with 100 kHz

- for areas with extreme medial exposure (conformal coating); ambient temperature -20 ... +60 °C
- for areas with extreme medial exposure (conformal coating); ambient temperature -40 ... +70 °C

6AG1 212-1AE31-4XB0

6AG1 212-1AE31-2XB0

SIPLUS CPU 1212C

compact CPU, DC/DC/relay

(extended temperature range and medial exposure)

Integrated program and data memory of 25 KB, load memory of 1 MB; power supply 24 V DC; Boolean execution times of 0.1 ms per operation; 8 digital inputs, 6 digital outputs (relay), 2 analog inputs; expandable with up to 3 communication modules, 2 signal modules and 1 signal board/communication board; digital inputs usable as HSC with 100 kHz

- for areas with extreme medial exposure (conformal coating); ambient temperature -20 ... +60 °C
- for areas with extreme medial exposure (conformal coating); ambient temperature -40 ... +70 °C

6AG1 212-1HE31-4XB0

6AG1 212-1HE31-2XB0

Accessories

SIPLUS SB 1223

digital input/output signal board

(extended temperature range and medial exposure)

2 inputs, 24 V DC, IEC type 1 current sinking; 2 transistor outputs 24 V DC, 0.5 A, 5 W; can be used as HSC at up to 30 kHz

- Suitable for areas with extraordinary medial exposure (conformal coating)
- Ambient temperature -25 ... +55 °C

6AG1 223-0BD30-4XB0

6AG1 223-0BD30-5XB0

2 inputs, 5 V DC, 200 kHz; 2 outputs 5 V DC, 0.1 A, 200 kHz

- for areas with extreme medial exposure (conformal coating), ambient temperature -25 ... +55 °C

6AG1 223-3AD30-5XB0

SIPLUS SB 1232

analog output signal board

(extended temperature range and medial exposure)

Ambient temperature range
-25 ... +55 °C

1 analog output, ±10 V with 12 bits or 0 ... 20 mA with 11 bits

6AG1 232-4HA30-5XB0

Ambient temperature range
0 ... +55 °C

1 analog output, ±10 V with 12 bits or 0 ... 20 mA with 11 bits

6AG1 232-4HA30-4XB0

Additional accessories

See SIMATIC S7-1200 CPU 1212C, page 3/10

SIMATIC S7-1200

SIPLUS central processing units

SIPLUS CPU 1214C

Overview



- The compact high-performance CPU
- With 24 integrated I/Os
- Expandable with:
 - 1 signal board (SB) or communication board (CB)
 - 8 signal modules (SM)
 - Max. 3 communication modules (CM)

Note:

SIPLUS extreme products are based on Siemens Industry standard products. The contents listed here were taken from the respective standard products. SIPLUS extreme-specific information was added.

3

Technical specifications

The technical data correspond to those of the based-on modules apart from the values listed in the table.

	6AG1 214-1AG31-4XB0 CPU 1214C DC/DC/DC	6AG1 214-1AG31-5XB0 CPU 1214C DC/DC/DC	6AG1 214-1AG31-2XB0 CPU 1214C DC/DC/DC
Based on	6ES7 214-1AG31-0XB0	6ES7 214-1AG31-0XB0	6ES7 214-1AG31-0XB0
Ambient conditions			
Operating temperature			
• Min.	-20 °C; = Tmin; startup @ 0 °C	-40 °C; = Tmin; startup @ -25 °C	-40 °C; = Tmin; startup @ -25 °C
• max.	60 °C; = Tmax	60 °C; = Tmax	70 °C; = Tmax; > +60 °C Number of simultaneously controllable inputs and outputs max. 50%; no signal board can be used
• horizontal installation, min.	-20 °C; = Tmin; startup @ 0 °C	-40 °C; = Tmin; startup @ -25 °C	-40 °C; = Tmin; startup @ -25 °C
• horizontal installation, max.	60 °C; = Tmax	60 °C; = Tmax	70 °C; = Tmax; > +60 °C Number of simultaneously controllable inputs and outputs max. 50%; no signal board can be used
• vertical installation, min.	-20 °C; = Tmin; startup @ 0 °C	-40 °C; = Tmin; startup @ -25 °C	-40 °C; = Tmin; startup @ -25 °C
• vertical installation, max.	50 °C; = Tmax	50 °C; = Tmax	50 °C; = Tmax
Storage/transport temperature			
• Min.	-40 °C	-40 °C	-40 °C
• max.	70 °C	70 °C	70 °C
Vibrations			
• Vibrations	2G wall mounting, 1G DIN rail	2G wall mounting, 1G DIN rail	2G wall mounting, 1G DIN rail
• Operation, checked according to IEC 60068-2-6	Yes	Yes	Yes
Shock test			
• checked according to IEC 60068-2-27	Yes; IEC 68, Part 2-27 half-sine: strength of the shock 15 g (peak value), duration 11 ms	Yes; IEC 68, Part 2-27 half-sine: strength of the shock 15 g (peak value), duration 11 ms	Yes; IEC 68, Part 2-27 half-sine: strength of the shock 15 g (peak value), duration 11 ms

SIMATIC S7-1200

SIPLUS central processing units

SIPLUS CPU 1214C

Technical specifications (continued)

	6AG1 214-1AG31-4XB0 CPU 1214C DC/DC/DC	6AG1 214-1AG31-5XB0 CPU 1214C DC/DC/DC	6AG1 214-1AG31-2XB0 CPU 1214C DC/DC/DC
Based on	6ES7 214-1AG31-0XB0	6ES7 214-1AG31-0XB0	6ES7 214-1AG31-0XB0
Extended ambient conditions			
<ul style="list-style-type: none"> Relative to ambient temperature-atmospheric pressure-installation altitude 	Tmin ... Tmax at 1080 hPa ... 795 hPa (-1000 m ... +2000 m) // Tmin ... (Tmax - 10K) at 795 hPa ... 658 hPa (+2000 m ... +3500 m) // Tmin ... (Tmax - 20K) at 658 hPa ... 540 hPa (+3500 m ... +5000 m) 0 °C	Tmin ... Tmax at 1080 hPa ... 795 hPa (-1000 m ... +2000 m) // Tmin ... (Tmax - 10K) at 795 hPa ... 658 hPa (+2000 m ... +3500 m) // Tmin ... (Tmax - 20K) at 658 hPa ... 540 hPa (+3500 m ... +5000 m) -25 °C	Tmin ... Tmax at 1080 hPa ... 795 hPa (-1000 m ... +2000 m) // Tmin ... (Tmax - 10K) at 795 hPa ... 658 hPa (+2000 m ... +3500 m) // Tmin ... (Tmax - 20K) at 658 hPa ... 540 hPa (+3500 m ... +5000 m) -25 °C
<ul style="list-style-type: none"> at cold restart Relative humidity <ul style="list-style-type: none"> - with condensation 	100 %; RH incl. condensation/frost (no commissioning under condensation conditions)	100 %; RH incl. condensation/frost (no commissioning under condensation conditions)	100 %; RH incl. condensation/frost (no commissioning under condensation conditions)
<ul style="list-style-type: none"> Resistance <ul style="list-style-type: none"> - to biologically active substances - to chemically active substances - to mechanically active substances 	Yes; Class 3B2 mold, fungus and dry rot spores (with the exception of fauna). The supplied connector covers must remain on the unused interfaces during operation! Yes Yes; Class 3S4 incl. sand, dust. The supplied connector covers must remain on the unused interfaces during operation!	Yes; Class 3B2 mold, fungus and dry rot spores (with the exception of fauna). The supplied connector covers must remain on the unused interfaces during operation! Yes Yes; Class 3S4 incl. sand, dust. The supplied connector covers must remain on the unused interfaces during operation!	Yes; Class 3B2 mold, fungus and dry rot spores (with the exception of fauna). The supplied connector covers must remain on the unused interfaces during operation! Yes Yes; Class 3S4 incl. sand, dust. The supplied connector covers must remain on the unused interfaces during operation!

Technical specifications (continued)

	6AG1 214-1BG31-4XB0 CPU 1214C AC/DC/Relay	6AG1 214-1BG31-5XB0 CPU 1214C AC/DC/Relay	6AG1 214-1BG31-2XB0 CPU 1214C AC/DC/Relay
Based on	6ES7 214-1BG31-0XB0	6ES7 214-1BG31-0XB0	6ES7 214-1BG31-0XB0
Ambient conditions			
Operating temperature			
• Min.	-20 °C; = Tmin; startup @ 0 °C	-40 °C; = Tmin; startup @ -25 °C	-40 °C; = Tmin; startup @ -25 °C
• max.	60 °C; = Tmax	60 °C	70 °C; = Tmax; > +60 °C Number of simultaneously controllable inputs and outputs max. 50%; no signal board can be used
• horizontal installation, min.	-20 °C; = Tmin; startup @ 0 °C	-40 °C; = Tmin; startup @ -25 °C	-40 °C; = Tmin; startup @ -25 °C
• horizontal installation, max.	60 °C; = Tmax	60 °C	70 °C; = Tmax; > +60 °C Number of simultaneously controllable inputs and outputs max. 50%; no signal board can be used
• vertical installation, min.	-20 °C; = Tmin; startup @ 0 °C	-40 °C; = Tmin; startup @ -25 °C	-40 °C; = Tmin; startup @ -25 °C
• vertical installation, max.	50 °C; = Tmax	50 °C; = Tmax	50 °C; = Tmax
Storage/transport temperature			
• Min.	-40 °C	-40 °C	-40 °C
• max.	70 °C	70 °C	70 °C
Vibrations			
• Vibrations	2G wall mounting, 1G DIN rail	2G wall mounting, 1G DIN rail	2G wall mounting, 1G DIN rail
• Operation, checked according to IEC 60068-2-6	Yes	Yes	Yes
Shock test			
• checked according to IEC 60068-2-27	Yes; IEC 68, Part 2-27 half-sine: strength of the shock 15 g (peak value), duration 11 ms	Yes; IEC 68, Part 2-27 half-sine: strength of the shock 15 g (peak value), duration 11 ms	Yes; IEC 68, Part 2-27 half-sine: strength of the shock 15 g (peak value), duration 11 ms
Extended ambient conditions			
• Relative to ambient temperature-atmospheric pressure-installation altitude	Tmin ... Tmax at 1080 hPa ... 795 hPa (-1000 m ... +2000 m) // Tmin ... (Tmax - 10K) at 795 hPa ... 658 hPa (+2000 m ... +3500 m) // Tmin ... (Tmax - 20K) at 658 hPa ... 540 hPa (+3500 m ... +5000 m) 0 °C	Tmin ... Tmax at 1080 hPa ... 795 hPa (-1000 m ... +2000 m) // Tmin ... (Tmax - 10K) at 795 hPa ... 658 hPa (+2000 m ... +3500 m) // Tmin ... (Tmax - 20K) at 658 hPa ... 540 hPa (+3500 m ... +5000 m) -25 °C	Tmin ... Tmax at 1080 hPa ... 795 hPa (-1000 m ... +2000 m) // Tmin ... (Tmax - 10K) at 795 hPa ... 658 hPa (+2000 m ... +3500 m) // Tmin ... (Tmax - 20K) at 658 hPa ... 540 hPa (+3500 m ... +5000 m) -25 °C
• at cold restart			
• Relative humidity	100 %; RH incl. condensation/frost (no commissioning under condensation conditions)	100 %; RH incl. condensation/frost (no commissioning under condensation conditions)	100 %; RH incl. condensation/frost (no commissioning under condensation conditions)
- with condensation			
• Resistance	Yes; Class 3B2 mold, fungus and dry rot spores (with the exception of fauna). The supplied connector covers must remain on the unused interfaces during operation!	Yes; Class 3B2 mold, fungus and dry rot spores (with the exception of fauna). The supplied connector covers must remain on the unused interfaces during operation!	Yes; Class 3B2 mold, fungus and dry rot spores (with the exception of fauna). The supplied connector covers must remain on the unused interfaces during operation!
- to biologically active substances	Yes	Yes	Yes
- to chemically active substances	Yes; Class 3S4 incl. sand, dust. The supplied connector covers must remain on the unused interfaces during operation!	Yes; Class 3S4 incl. sand, dust. The supplied connector covers must remain on the unused interfaces during operation!	Yes; Class 3S4 incl. sand, dust. The supplied connector covers must remain on the unused interfaces during operation!
- to mechanically active substances			

SIMATIC S7-1200

SIPLUS central processing units

SIPLUS CPU 1214C

Technical specifications (continued)

	6AG1 214-1HG31-4XB0 CPU 1214C DC/DC/Relay	6AG1 214-1HG31-5XB0 CPU 1214C DC/DC/Relay	6AG1 214-1HG31-2XB0 CPU 1214C DC/DC/Relay
Based on	6ES7 214-1HG31-0XB0	6ES7 214-1HG31-0XB0	6ES7 214-1HG31-0XB0
Ambient conditions			
Operating temperature			
• Min.	-20 °C; = Tmin; startup @ 0 °C	-40 °C; = Tmin; startup @ -25 °C	-40 °C; = Tmin; startup @ -25 °C
• max.	60 °C; = Tmax	60 °C; = Tmax	70 °C; = Tmax; > +60 °C Number of simultaneously controllable inputs and outputs max. 50%; no signal board can be used
• horizontal installation, min.	-20 °C; = Tmin; startup @ 0 °C	-40 °C; = Tmin; startup @ -25 °C	-40 °C; = Tmin; startup @ -25 °C
• horizontal installation, max.	60 °C; = Tmax	60 °C; = Tmax	70 °C; = Tmax; > +60 °C Number of simultaneously controllable inputs and outputs max. 50%; no signal board can be used
• vertical installation, min.	-20 °C; = Tmin; startup @ 0 °C	-40 °C; = Tmin; startup @ -25 °C	-40 °C; = Tmin; startup @ -25 °C
• vertical installation, max.	50 °C; = Tmax	50 °C; = Tmax	50 °C; = Tmax
Storage/transport temperature			
• Min.	-40 °C	-40 °C	-40 °C
• max.	70 °C	70 °C	70 °C
Vibrations			
• Vibrations	2G wall mounting, 1G DIN rail	2G wall mounting, 1G DIN rail	2G wall mounting, 1G DIN rail
• Operation, checked according to IEC 60068-2-6	Yes	Yes	Yes
Shock test			
• checked according to IEC 60068-2-27	Yes; IEC 68, Part 2-27 half-sine: strength of the shock 15 g (peak value), duration 11 ms	Yes; IEC 68, Part 2-27 half-sine: strength of the shock 15 g (peak value), duration 11 ms	Yes; IEC 68, Part 2-27 half-sine: strength of the shock 15 g (peak value), duration 11 ms
Extended ambient conditions			
• Relative to ambient temperature-atmospheric pressure-installation altitude	Tmin ... Tmax at 1080 hPa ... 795 hPa (-1000 m ... +2000 m) // Tmin ... (Tmax - 10K) at 795 hPa ... 658 hPa (+2000 m ... +3500 m) // Tmin ... (Tmax - 20K) at 658 hPa ... 540 hPa (+3500 m ... +5000 m) 0 °C	Tmin ... Tmax at 1080 hPa ... 795 hPa (-1000 m ... +2000 m) // Tmin ... (Tmax - 10K) at 795 hPa ... 658 hPa (+2000 m ... +3500 m) // Tmin ... (Tmax - 20K) at 658 hPa ... 540 hPa (+3500 m ... +5000 m) -25 °C	Tmin ... Tmax at 1080 hPa ... 795 hPa (-1000 m ... +2000 m) // Tmin ... (Tmax - 10K) at 795 hPa ... 658 hPa (+2000 m ... +3500 m) // Tmin ... (Tmax - 20K) at 658 hPa ... 540 hPa (+3500 m ... +5000 m) -25 °C
• at cold restart			
• Relative humidity			
- with condensation	100 %; RH incl. condensation/frost (no commissioning under condensation conditions)	100 %; RH incl. condensation/frost (no commissioning under condensation conditions)	100 %; RH incl. condensation/frost (no commissioning under condensation conditions)
• Resistance			
- to biologically active substances	Yes; Class 3B2 mold, fungus and dry rot spores (with the exception of fauna). The supplied connector covers must remain on the unused interfaces during operation!	Yes; Class 3B2 mold, fungus and dry rot spores (with the exception of fauna). The supplied connector covers must remain on the unused interfaces during operation!	Yes; Class 3B2 mold, fungus and dry rot spores (with the exception of fauna). The supplied connector covers must remain on the unused interfaces during operation!
- to chemically active substances	Yes	Yes	Yes
- to mechanically active substances	Yes; Class 3S4 incl. sand, dust. The supplied connector covers must remain on the unused interfaces during operation!	Yes; Class 3S4 incl. sand, dust. The supplied connector covers must remain on the unused interfaces during operation!	Yes; Class 3S4 incl. sand, dust. The supplied connector covers must remain on the unused interfaces during operation!

Ordering data	Order No.	Order No.	
<p>SIPLUS CPU 1214C compact CPU, AC/DC/relay</p> <p>(extended temperature range and medial exposure)</p> <p>Integrated program and data memory of 50 KB, load memory of 2 MB; wide-range alternating voltage supply 85 ... 264 V AC; Boolean execution times of 0.1 ms per operation;</p> <p>14 digital inputs, 10 digital outputs (relay), 2 analog inputs; expandable with up to 3 communication modules, 8 signal modules, and 1 signal board/communication board; digital inputs usable as HSC with 100 kHz</p> <ul style="list-style-type: none"> • For areas with extreme medial exposure (conformal coating); ambient temperature -20 ... +60 °C • For areas with extreme medial exposure (conformal coating); ambient temperature -40 ... +60 °C • For areas with extreme medial exposure (conformal coating); ambient temperature -40 ... +70 °C 	<p>6AG1 214-1BG31-4XB0</p> <p>6AG1 214-1BG31-5XB0</p> <p>6AG1 214-1BG31-2XB0</p>	<p>SIPLUS CPU 1214C compact CPU, DC/DC/relay</p> <p>(extended temperature range and medial exposure)</p> <p>Integrated program and data memory of 50 KB, load memory of 2 MB; power supply 24 V DC; Boolean execution times of 0.1 ms per operation;</p> <p>14 digital inputs, 10 digital outputs (relay), 2 analog inputs; expandable with up to 3 communication modules, 8 signal modules and 1 signal board/communication board; digital inputs usable as HSC with 100 kHz</p> <ul style="list-style-type: none"> • For areas with extreme medial exposure (conformal coating); ambient temperature -20 ... +60 °C • For areas with extreme medial exposure (conformal coating); ambient temperature -40 ... +60 °C • For areas with extreme medial exposure (conformal coating); ambient temperature -40 ... +70 °C 	<p>6AG1 214-1HG31-4XB0</p> <p>6AG1 214-1HG31-5XB0</p> <p>6AG1 214-1HG31-2XB0</p>
<p>SIPLUS CPU 1214C compact CPU, DC/DC/DC</p> <p>(extended temperature range and medial exposure)</p> <p>Integrated program and data memory of 50 KB, load memory of 2 MB; power supply 24 V DC; Boolean execution times of 0.1 ms per operation;</p> <p>14 digital inputs, 10 digital outputs, 2 analog inputs; expandable with up to 3 communication modules, 8 signal modules and 1 signal board/communication board; digital inputs usable as HSC with 100 kHz, 24 V DC digital outputs usable as pulse outputs (PTO) or pulse-width-modulated outputs (PWM) with 100 kHz</p> <ul style="list-style-type: none"> • for areas with extreme medial exposure (conformal coating); ambient temperature -20 ... +60 °C • For areas with extreme medial exposure (conformal coating); ambient temperature -40 ... +60 °C • For areas with extreme medial exposure (conformal coating); ambient temperature -40 ... +70 °C 	<p>6AG1 214-1AG31-4XB0</p> <p>6AG1 214-1AG31-5XB0</p> <p>6AG1 214-1AG31-2XB0</p>	<p>Accessories</p> <p>SIPLUS SB 1223 digital input/outputsignal board</p> <p>(extended temperature range and medial exposure)</p> <p>2 inputs, 24 V DC, IEC type 1 current sinking; 2 transistor outputs 24 V DC, 0.5 A, 5 W; can be used as HSC at up to 30 kHz</p> <ul style="list-style-type: none"> • Suitable for areas with extraordinary medial exposure (conformal coating) • Ambient temperature -25 ... +55 °C <p>2 inputs, 5 V DC, 200 kHz; 2 outputs 5 V DC, 0.1 A, 200 kHz</p> <ul style="list-style-type: none"> • For areas with extreme medial exposure (conformal coating), ambient temperature -25 ... +55 °C 	<p>6AG1 223-0BD30-4XB0</p> <p>6AG1 223-0BD30-5XB0</p> <p>6AG1 223-3AD30-5XB0</p>
		<p>SIPLUS SB 1232 analog output signal board</p> <p>(extended temperature range and medial exposure)</p> <p><u>Ambient temperature range</u> -25 ... +55 °C</p> <p>1 analog output, ±10 V with 12 bits or 0 ... 20 mA with 11 bits</p> <p><u>Ambient temperature range</u> 0 ... +55 °C</p> <p>1 analog output, ±10 V with 12 bits or 0 ... 20 mA with 11 bits</p>	<p>6AG1 232-4HA30-5XB0</p> <p>6AG1 232-4HA30-4XB0</p>
		<p>Additional accessories</p>	<p>See SIMATIC S7-1200 CPU 1214C, page 3/14</p>

SIMATIC S7-1200

SIPLUS central processing units

SIPLUS CPU 1215C

Overview



- The compact high-performance CPU
- With 24 integrated I/Os
- Expandable by:
 - 1 signal board (SB) or communication board (CB)
 - 8 signal modules (SM)
 - Max. 3 communication modules (CM)

Note:

SIPLUS extreme products are based on Siemens Industry standard products. The contents listed here were taken from the respective standard products. SIPLUS extreme-specific information was added.

Technical specifications

The technical data correspond to those of the based-on modules apart from the values listed in the table.

Based on	6AG1 215-1AG31-4XB0 CPU 1215C DC/DC/DC 6ES7 215-1AG31-0XB0	6AG1 215-1AG31-5XB0 CPU 1215C DC/DC/DC 6ES7 215-1AG31-0XB0	6AG1 215-1AG31-2XB0 CPU 1215C DC/DC/DC 6ES7 215-1AG31-0XB0
Ambient conditions			
Operating temperature			
• Min.	-20 °C; = Tmin; startup @ 0 °C	-40 °C; = Tmin; startup @ -25 °C	-40 °C; = Tmin; startup @ -25 °C
• max.	60 °C; = Tmax	60 °C; = Tmax	70 °C; = Tmax; > +60 °C Number of simultaneously controllable inputs and outputs max. 50%; no signal board can be used
• horizontal installation, min.	-20 °C; = Tmin; startup @ 0 °C	-40 °C; = Tmin; startup @ -25 °C	-40 °C; = Tmin; startup @ -25 °C
• horizontal installation, max.	60 °C; = Tmax	60 °C; = Tmax	70 °C; = Tmax; > +60 °C Number of simultaneously controllable inputs and outputs max. 50%; no signal board can be used
• vertical installation, min.	-20 °C; = Tmin; startup @ 0 °C	-40 °C; = Tmin; startup @ -25 °C	-40 °C; = Tmin; startup @ -25 °C
• vertical installation, max.	50 °C; = Tmax	50 °C; = Tmax	50 °C; = Tmax
Storage/transport temperature			
• Min.	-40 °C	-40 °C	-40 °C
• max.	70 °C	70 °C	70 °C
Vibrations			
• Vibrations	2G wall mounting, 1G DIN rail	2G wall mounting, 1G DIN rail	2G wall mounting, 1G DIN rail
• Operation, checked according to IEC 60068-2-6	Yes	Yes	Yes
Shock test			
• checked according to IEC 60068-2-27	Yes; IEC 68, Part 2-27 half-sine: strength of the shock 15 g (peak value), duration 11 ms	Yes; IEC 68, Part 2-27 half-sine: strength of the shock 15 g (peak value), duration 11 ms	Yes; IEC 68, Part 2-27 half-sine: strength of the shock 15 g (peak value), duration 11 ms
Extended ambient conditions			
• Relative to ambient temperature-atmospheric pressure-installation altitude	Tmin ... Tmax at 1080 hPa ... 795 hPa (-1000 m ... +2000 m) // Tmin ... (Tmax - 10K) at 795 hPa ... 658 hPa (+2000 m ... +3500 m) // Tmin ... (Tmax - 20K) at 658 hPa ... 540 hPa (+3500 m ... +5000 m)		
• at cold restart	0 °C	-25 °C	-25 °C
• Relative humidity			
- with condensation	100 %; RH incl. condensation/frost (no commissioning under condensation conditions)	100 %; RH incl. condensation/frost (no commissioning under condensation conditions)	100 %; RH incl. condensation/frost (no commissioning under condensation conditions)
• Resistance			
- to biologically active substances	Yes; Class 3B2 mold, fungus and dry rot spores (with the exception of fauna). The supplied connector covers must remain on the unused interfaces during operation!	Yes; Class 3B2 mold, fungus and dry rot spores (with the exception of fauna). The supplied connector covers must remain on the unused interfaces during operation!	Yes; Class 3B2 mold, fungus and dry rot spores (with the exception of fauna). The supplied connector covers must remain on the unused interfaces during operation!
- to chemically active substances	Yes	Yes	Yes
- to mechanically active substances	Yes; Class 3S4 incl. sand, dust. The supplied connector covers must remain on the unused interfaces during operation!	Yes; Class 3S4 incl. sand, dust. The supplied connector covers must remain on the unused interfaces during operation!	Yes; Class 3S4 incl. sand, dust. The supplied connector covers must remain on the unused interfaces during operation!

Technical specifications (continued)

	6AG1 215-1AG31-4XB0 CPU 1215C DC/DC/DC	6AG1 215-1AG31-5XB0 CPU 1215C DC/DC/DC	6AG1 215-1AG31-2XB0 CPU 1215C DC/DC/DC
Based on	6ES7 215-1AG31-0XB0	6ES7 215-1AG31-0XB0	6ES7 215-1AG31-0XB0
Climatic and mechanical conditions for storage and transport			
Climatic conditions for storage and transport			
• Free fall	0.3 m; five times, in dispatch package	0.3 m; five times, in dispatch package	0.3 m; five times, in dispatch package
• Temperature			
- Permissible temperature range	-40 °C to +70 °C	-40 °C to +70 °C	-40 °C to +70 °C
	6AG1 215-1BG31-4XB0 CPU 1215C AC/DC/Relay	6AG1 215-1BG31-5XB0 CPU 1215C AC/DC/Relay	6AG1 215-1BG31-2XB0 CPU 1215C AC/DC/Relay
Based on	6ES7 215-1BG31-0XB0	6ES7 215-1BG31-0XB0	6ES7 215-1BG31-0XB0
Ambient conditions			
Operating temperature			
• Min.	-20 °C; = Tmin; startup @ 0 °C	-40 °C; = Tmin; startup @ -25 °C	-40 °C; = Tmin; startup @ -25 °C
• max.	60 °C; = Tmax	60 °C; = Tmax	70 °C; = Tmax; > +60 °C Number of simultaneously controllable inputs and outputs max. 50%; no signal board can be used
• horizontal installation, min.	-20 °C; = Tmin; startup @ 0 °C	-40 °C; = Tmin; startup @ -25 °C	-40 °C; = Tmin; startup @ -25 °C
• horizontal installation, max.	60 °C; = Tmax	60 °C; = Tmax	70 °C; = Tmax; > +60 °C Number of simultaneously controllable inputs and outputs max. 50%; no signal board can be used
• vertical installation, min.	-20 °C; = Tmin; startup @ 0 °C	-40 °C; = Tmin; startup @ -25 °C	-40 °C; = Tmin; startup @ -25 °C
• vertical installation, max.	50 °C; = Tmax	50 °C; = Tmax	50 °C; = Tmax
Storage/transport temperature			
• Min.	-40 °C	-40 °C	-40 °C
• max.	70 °C	70 °C	70 °C
Vibrations			
• Vibrations	2G wall mounting, 1G DIN rail	2G wall mounting, 1G DIN rail	2G wall mounting, 1G DIN rail
• Operation, checked according to IEC 60068-2-6	Yes	Yes	Yes
Shock test			
• checked according to IEC 60068-2-27	Yes; IEC 68, Part 2-27 half-sine: strength of the shock 15 g (peak value), duration 11 ms	Yes; IEC 68, Part 2-27 half-sine: strength of the shock 15 g (peak value), duration 11 ms	Yes; IEC 68, Part 2-27 half-sine: strength of the shock 15 g (peak value), duration 11 ms
Extended ambient conditions			
• Relative to ambient temperature-atmospheric pressure-installation altitude	Tmin ... Tmax at 1080 hPa ... 795 hPa (-1000 m ... +2000 m) // Tmin ... (Tmax - 10K) at 795 hPa ... 658 hPa (+2000 m ... +3500 m) // Tmin ... (Tmax - 20K) at 658 hPa ... 540 hPa (+3500 m ... +5000 m)		
• at cold restart	0 °C	-25 °C	-25 °C
• Relative humidity			
- with condensation	100 %; RH incl. condensation/frost (no commissioning under condensation conditions)	100 %; RH incl. condensation/frost (no commissioning under condensation conditions)	100 %; RH incl. condensation/frost (no commissioning under condensation conditions)
• Resistance			
- to biologically active substances	Yes; Class 3B2 mold, fungus and dry rot spores (with the exception of fauna). The supplied connector covers must remain on the unused interfaces during operation!		
- to chemically active substances	Yes		
- to mechanically active substances	Yes; Class 3S4 incl. sand, dust. The supplied connector covers must remain on the unused interfaces during operation!		
Climatic and mechanical conditions for storage and transport			
Climatic conditions for storage and transport			
• Free fall	0.3 m; five times, in dispatch package	0.3 m; five times, in dispatch package	0.3 m; five times, in dispatch package
• Temperature			
- Permissible temperature range	-40 °C to +70 °C	-40 °C to +70 °C	-40 °C to +70 °C

SIMATIC S7-1200

SIPLUS central processing units

SIPLUS CPU 1215C

Technical specifications (continued)

Based on	6AG1 215-1HG31-4XB0 CPU 1215C DC/DC/Relay	6ES7 215-1HG31-0XB0
Ambient conditions		
Operating temperature		
• Min.	-20 °C; = Tmin; startup @ 0 °C	
• max.	60 °C; = Tmax	
• horizontal installation, min.	-20 °C; = Tmin; startup @ 0 °C	
• horizontal installation, max.	60 °C; = Tmax	
• vertical installation, min.	-20 °C; = Tmin; startup @ 0 °C	
• vertical installation, max.	50 °C; = Tmax	
Storage/transport temperature		
• Min.	-40 °C	
• max.	70 °C	
Vibrations		
• Vibrations	2G wall mounting, 1G DIN rail	
• Operation, checked according to IEC 60068-2-6	Yes	
Shock test		
• checked according to IEC 60068-2-27	Yes; IEC 68, Part 2-27 half-sine: strength of the shock 15 g (peak value), duration 11 ms	
Extended ambient conditions		
• Relative to ambient temperature-atmospheric pressure-installation altitude	Tmin ... Tmax at 1080 hPa ... 795 hPa (-1000 m ... +2000 m) // Tmin ... (Tmax - 10K) at 795 hPa ... 658 hPa (+2000 m ... +3500 m) // Tmin ... (Tmax - 20K) at 658 hPa ... 540 hPa (+3500 m ... +5000 m) 0 °C	
• at cold restart		

Based on	6AG1 215-1HG31-4XB0 CPU 1215C DC/DC/Relay	6ES7 215-1HG31-0XB0
• Relative humidity		100 %; RH incl. condensation/frost (no commissioning under condensation conditions)
- with condensation		
• Resistance		Yes; Class 3B2 mold, fungus and dry rot spores (with the exception of fauna). The supplied connector covers must remain on the unused interfaces during operation!
- to biologically active substances		Yes
- to chemically active substances		Yes; Class 3S4 incl. sand, dust. The supplied connector covers must remain on the unused interfaces during operation!
- to mechanically active substances		
Climatic and mechanical conditions for storage and transport		
Climatic conditions for storage and transport		
• Free fall		0.3 m; five times, in dispatch package
- Drop height, max. (in packaging)		
• Temperature		-40 °C to +70 °C
- Permissible temperature range		

Ordering data

SIPLUS CPU 1215C compact CPU, AC/DC/relay

(extended temperature range and medial exposure)

Integrated program and data memory 100 KB, load memory 4 MB; wide-range power supply 85 ... 264 V AC; Boolean execution times 0.085 µs per operation; 14 digital inputs, 10 digital outputs (relay), 2 analog inputs, 2 analog outputs; expandable by up to 3 communication modules, 8 signal modules and 1 signal board/communication board; digital inputs usable as HSC with 100 kHz

- For areas with extreme medial exposure (conformal coating); ambient temperature -20 ... +60 °C
- For areas with extreme medial exposure (conformal coating); ambient temperature -40 ... +60 °C
- For areas with extreme medial exposure (conformal coating); ambient temperature -40 ... +70 °C

Order No.

6AG1 215-1BG31-4XB0

6AG1 215-1BG31-5XB0

6AG1 215-1BG31-2XB0

SIPLUS CPU 1215C compact CPU, DC/DC/DC

(extended temperature range and medial exposure)

Integrated program and data memory 100 KB, load memory 4 MB; power supply 24 V DC; Boolean execution times 0.085 µs per operation; 14 digital inputs, 10 digital outputs, 2 analog inputs, 2 analog outputs; expandable by up to 3 communication modules, 8 signal modules and 1 signal board/communication board; digital inputs usable as HSC with 100 kHz; 24 V DC digital outputs usable as pulse outputs (PTO) or pulse-width-modulated outputs (PWM) with 100 kHz

- For areas with extreme medial exposure (conformal coating); ambient temperature -20 ... +60 °C
- For areas with extreme medial exposure (conformal coating); ambient temperature -40 ... +60 °C
- For areas with extreme medial exposure (conformal coating); ambient temperature -40 ... +70 °C

Order No.

6AG1 215-1AG31-4XB0

6AG1 215-1AG31-5XB0

6AG1 215-1AG31-2XB0

Ordering data	Order No.	Order No.	Order No.
<p>SIPLUS CPU 1215C compact CPU, DC/DC/relay</p> <p>(extended temperature range and medial exposure)</p> <p>Integrated program and data memory 100 KB, load memory 4 MB; power supply 24 V DC; Boolean execution times 0.085 µs per operation; 14 digital inputs, 10 digital outputs (relay), 2 analog inputs, 2 analog outputs; expandable by up to 3 communication modules, 8 signal modules and 1 signal board/communication board; digital inputs usable as HSC with 100 kHz</p> <ul style="list-style-type: none"> • For areas with extreme medial exposure (conformal coating); ambient temperature -20 ... +60 °C • For areas with extreme medial exposure (conformal coating); ambient temperature -40 ... +60 °C • For areas with extreme medial exposure (conformal coating); ambient temperature -40 ... +70 °C 	<p>6AG1 215-1HG31-4XB0</p> <p>6AG1 215-1HG31-5XB0</p> <p>6AG1 215-1HG31-2XB0</p>	<p>Accessories</p> <p>SIPLUS SB 1223 digital input/output signal board</p> <p>(extended temperature range and medial exposure)</p> <p>2 inputs, 24 V DC, IEC type 1 current sinking; 2 transistor outputs 24 V DC, 0.5 A, 5 W; can be used as HSC at up to 30 kHz</p> <ul style="list-style-type: none"> • Suitable for areas with extraordinary medial exposure (conformal coating) • Ambient temperature -25 ... +55 °C <p>2 inputs, 5 V DC, 200 kHz; 2 outputs 5 V DC, 0.1 A, 200 kHz</p> <ul style="list-style-type: none"> • For areas with extreme medial exposure (conformal coating), ambient temperature -25 ... +55 °C <p>SIPLUS SB 1232 analog output signal board</p> <p>(extended temperature range and medial exposure)</p> <p><u>Ambient temperature range</u> -25 ... +55 °C</p> <p>1 analog output, ±10 V with 12 bits or 0 ... 20 mA with 11 bits</p> <p><u>Ambient temperature range</u> 0 ... +55 °C</p> <p>1 analog output, ±10 V with 12 bits or 0 ... 20 mA with 11 bits</p> <p>Additional accessories</p>	<p>6AG1 223-0BD30-4XB0</p> <p>6AG1 223-0BD30-5XB0</p> <p>6AG1 223-3AD30-5XB0</p> <p>6AG1 232-4HA30-5XB0</p> <p>6AG1 232-4HA30-4XB0</p> <p>See SIMATIC S7-1200 CPU 1215C, page 3/18</p>

SIMATIC S7-1200

Digital modules

SM 1221 digital input modules

Overview



- Digital inputs as supplement to the integral I/O of the CPUs
- For flexible adaptation of the controller to the relevant task
- For subsequent expansion of the system with additional inputs

3

Technical specifications

	6ES7 221-1BF32-0XB0 SM 1221 DI 8x24 VDC	6ES7 221-1BH32-0XB0 SM 1221 DI 16x24 VDC
Supply voltage 24 V DC	Yes	Yes
permissible range, upper limit (DC)	28.8 V	28.8 V
Input current from backplane bus 5 V DC, max.	105 mA	130 mA
Digital inputs • from load voltage L+ (without load), max.	4 mA; per channel	4 mA; per channel
Output voltage Power supply to the transmitters • present	Yes	Yes
Power losses Power loss, typ.	1.5 W	2.5 W
Digital inputs Number/binary inputs • In groups of	8 2	16 4
Input characteristic curve acc. to IEC 61131, Type 1	Yes	Yes
Number of simultaneously controllable inputs • all mounting positions - up to 40 °C, max.	8	16
• horizontal installation - up to 40 °C, max.	8	16
- up to 50 °C, max.	8	16
• vertical installation - up to 40 °C, max.	8	16
Input voltage • Type of input voltage • Rated value, DC	24 V	DC 24 V

Technical specifications (continued)

	6ES7 221-1BF32-0XB0 SM 1221 DI 8x24 VDC	6ES7 221-1BH32-0XB0 SM 1221 DI 16x24 VDC
Input current • for signal "0", max. (permissible quiescent current) • for signal "1", min. • for signal "1", typ.	1 mA 2.5 mA 4 mA; Typical	1 mA 2.5 mA 4 mA; Typical
Input delay (for rated value of input voltage) • for standard inputs - Parameterizable • for interrupt inputs - Parameterizable	Yes; 0.2, 0.4, 0.8, 1.6, 3.2, 6.4, and 12.8 ms, selectable in groups of four Yes	Yes; 0.2, 0.4, 0.8, 1.6, 3.2, 6.4, and 12.8 ms, selectable in groups of four Yes
Cable length • Cable length, shielded, max. • Cable length unshielded, max.	500 m 300 m	500 m 300 m
Interrupts/diagnostics/ status information		
Alarms • Alarms • Diagnostic alarm	Yes Yes	Yes Yes
Diagnostic messages • Diagnostic functions • Monitoring the supply voltage	Yes Yes	Yes Yes
Diagnostics indication LED • for status of the inputs • for maintenance • Status indicator digital input (green)	Yes Yes Yes	Yes Yes Yes
Galvanic isolation Galvanic isolation digital inputs • between the channels, in groups of	2	4
Degree and class of protection IP20	Yes	Yes
Standards, approvals, certificates		
CE mark	Yes	Yes
CSA approval		Yes
C-TICK	Yes	Yes
FM approval	Yes	Yes
Marine approval		Yes
Climatic and mechanical conditions for storage and transport Climatic conditions for storage and transport • Free fall - Drop height, max. (in packaging) • Temperature - Permissible temperature range • Air pressure acc. to IEC 60068-2-13 - Permissible air pressure	0.3 m; five times, in dispatch package -40 °C to +70 °C 1080 to 660 hPa	0.3 m; five times, in dispatch package -40 °C to +70 °C 1080 to 660 hPa

SIMATIC S7-1200

Digital modules

SM 1221 digital input modules

Technical specifications (continued)

	6ES7 221-1BF32-0XB0 SM 1221 DI 8x24 VDC	6ES7 221-1BH32-0XB0 SM 1221 DI 16x24 VDC
Mechanical and climatic conditions during operation		
Climatic conditions in operation		
• Temperature		
- Min.		-20 °C
- max.		60 °C
- Permissible temperature change	5°C to 55°C, 3°C / minute	5°C to 55°C, 3°C / minute
Connection method		
required front connector	Yes	Yes
Mechanics/material		
Type of housing (front)		
• Plastic	Yes	Yes
Dimensions		
Width	45 mm	45 mm
Height	100 mm	100 mm
Depth	75 mm	75 mm
Weight		
Weight, approx.	170 g	210 g

Ordering data

	Order No.		Order No.
SM 1221 digital input signal module		S7-1200 automation system, System Manual	
8 inputs, 24 V DC, isolated, current sourcing/sinking	6ES7 221-1BF32-0XB0	For SIMATIC S7-1200 and STEP 7 Basic	
16 inputs, 24 V DC, isolated, current sourcing/sinking	6ES7 221-1BH32-0XB0	German	6ES7 298-8FA30-8AH0
Extension cable for two-tier configuration	6ES7 290-6AA30-0XA0	English	6ES7 298-8FA30-8BH0
for connecting digital/analog signal modules; length 2 m		French	6ES7 298-8FA30-8CH0
Terminal block (spare part)		Spanish	6ES7 298-8FA30-8DH0
for 8/16-channel digital signal modules		Italian	6ES7 298-8FA30-8EH0
with 7 screws, tin-plated; 4 pcs.	6ES7 292-1AG40-0XA0	Chinese	6ES7 298-8FA30-8KH0
Front flap set (spare part)		S7-1200 automation system, Easy Book	
for 8/16-channel signal modules	6ES7 291-1BA30-0XA0	Brief instructions	
		German	6ES7 298-8FA30-8AQ0
		English	6ES7 298-8FA30-8BQ0
		French	6ES7 298-8FA30-8CQ0
		Spanish	6ES7 298-8FA30-8DQ0
		Italian	6ES7 298-8FA30-8EQ0
		Chinese	6ES7 298-8FA30-8KQ0

Overview



- Digital inputs as a supplement to the integral I/O of SIMATIC S7-1200 CPUs
- Can be plugged directly into the CPU

Technical specifications

	6ES7 221-3AD30-0XB0 SB 1221 4xDI 5VDC 200kHz	6ES7 221-3BD30-0XB0 SB 1221 4xDI 24VDC 200kHz
Input current from backplane bus 5 V DC, typ.	50 mA	50 mA
Output voltage Power supply to the transmitters • Supply current, max.	4 mA; per channel	4 mA; per channel
Power losses Power loss, typ.	1 W	1 W
Digital inputs Number/binary inputs • In groups of	4; Current-sourcing 1	4; Current-sourcing 1
Input characteristic curve acc. to IEC 61131, Type 1	Yes	
Input characteristic curve acc. to IEC 61131, Type 2		Yes
Number of simultaneously controllable inputs • all mounting positions - up to 40 °C, max.	4	4
Input voltage • Rated value, DC • for signal "0" • for signal "1"	5 V 0 to 1 V 2 to 6 V	24 V 0 to 5 V 15 to 30 V
Input current • for signal "0", max. (permissible quiescent current) • for signal "1", min. • for signal "1", typ.	3 mA 6 mA	2 mA 5.8 mA 14 mA
Input delay (for rated value of input voltage) • for standard inputs - Parameterizable - at "0" to "1", max. • for interrupt inputs - Parameterizable • for counter/technological functions - Parameterizable	Yes; 0.2, 0.4, 0.8, 1.6, 3.2, 6.4, and 12.8 ms, selectable in groups of four 2 μs Yes Yes	Yes; 0.2, 0.4, 0.8, 1.6, 3.2, 6.4, and 12.8 ms, selectable in groups of four 2.5 μs Yes Yes
Cable length • Cable length, shielded, max.	50 m; Shielded, twisted wire pair	50 m; Standard input: 500 m, high-speed counters: 50 m

SIMATIC S7-1200

Digital modules

SB 1221 digital input modules

Technical specifications (continued)

	6ES7 221-3AD30-0XB0 SB 1221 4xDI 5VDC 200kHz	6ES7 221-3BD30-0XB0 SB 1221 4xDI 24VDC 200kHz
Interrupts/diagnostics/ status information		
Alarms		
• Alarms	Yes	Yes
Diagnostic messages		
• Diagnostic functions	Yes	Yes
Diagnostics indication LED		
• for status of the inputs	Yes	Yes
Degree and class of protection		
IP20	Yes	Yes
Standards, approvals, certificates		
Marine approval according to Germanischer Lloyd	Yes	Yes
Climatic and mechanical conditions for storage and transport		
Climatic conditions for storage and transport		
• Free fall		
- Drop height, max. (in packaging)	0.3 m; five times, in dispatch package	0.3 m; five times, in dispatch package
• Temperature		
- Permissible temperature range	-40 °C to +70 °C	-40 °C to +70 °C
• Air pressure acc. to IEC 60068-2-13		
- Permissible air pressure	1080 to 660 hPa	1080 to 660 hPa
Mechanical and climatic conditions during operation		
Climatic conditions in operation		
• Temperature		
- Permissible temperature range	0 °C to 55 °C horizontal installation 0 °C to 45 °C vertical installation	0 °C to 55 °C horizontal installation 0 °C to 45 °C vertical installation
Mechanics/material		
Type of housing (front)		
• Plastic	Yes	Yes
Dimensions		
Width	38 mm	38 mm
Height	62 mm	62 mm
Depth	21 mm	21 mm
Weight		
Weight, approx.	40 g	40 g

Ordering data	Order No.		Order No.
SB 1221 digital input signal boards		S7-1200 automation system, Easy Book	
4 inputs, 5 V DC, 200 kHz	6ES7 221-3AD30-0XB0	Brief instructions	
4 inputs, 24 V DC, 200 kHz	6ES7 221-3BD30-0XB0	German	6ES7 298-8FA30-8AQ0
Terminal block (spare part)		English	6ES7 298-8FA30-8BQ0
for signal board		French	6ES7 298-8FA30-8CQ0
with 6 screws, gold-plated; 4 pcs.	6ES7 292-1BF30-0XA0	Spanish	6ES7 298-8FA30-8DQ0
S7-1200 automation system, System Manual		Italian	6ES7 298-8FA30-8EQ0
for SIMATIC S7-1200 and STEP 7 Basic		Chinese	6ES7 298-8FA30-8KQ0
German	6ES7 298-8FA30-8AH0		
English	6ES7 298-8FA30-8BH0		
French	6ES7 298-8FA30-8CH0		
Spanish	6ES7 298-8FA30-8DH0		
Italian	6ES7 298-8FA30-8EH0		
Chinese	6ES7 298-8FA30-8KH0		

SIMATIC S7-1200

Digital modules

SM 1222 digital output modules

Overview



- Digital outputs as supplement to the integral I/O of the CPUs
- For flexible adaptation of the controller to the relevant task
- For subsequent expansion of the system with additional outputs

3

Technical specifications

	6ES7 222-1BF32-0XB0 SM 1222 DQ 8x24 VDC	6ES7 222-1BH32-0XB0 SM 1222 DQ 16x24 VDC	6ES7 222-1HF32-0XB0 SM 1222 DQ 8xRelay	6ES7 222-1HH32-0XB0 SM 1222 DQ 16xRelay	6ES7 222-1XF32-0XB0 SM 1222 DQ 8x relay changeover contact
Supply voltage					
permissible range, lower limit (DC)					5 V
permissible range, upper limit (DC)					30 V
Input current					
from backplane bus 5 V DC, max.	120 mA	140 mA	120 mA	135 mA	140 mA
Digital inputs					
• from load voltage L+ (without load), max.			11 mA/relay coil	11 mA/relay coil	16.7 mA/relay coil
Power losses					
Power loss, typ.	1.5 W	2.5 W	4.5 W	8.5 W	5 W
Digital inputs					
Number/binary inputs					0
Digital outputs					
Number/binary outputs	8	16	8	16	8
• In groups of	1	1	2	1	1
Functionality/short-circuit strength	No; to be provided externally	No; to be provided externally	No; to be provided externally	No; to be provided externally	No; to be provided externally
Limitation of inductive shutdown voltage to	typ. (L+) -48 V	typ. (L+) -48 V			
Switching capacity of the outputs					
• with resistive load, max.	0.5 A	0.5 A	2 A	2 A	2 A
• on lamp load, max.	5 W	5 W			
Output voltage					
• Rated value (AC)					5 to 250 V AC
• Rated value (DC)					5 to 30 V DC
• for signal "0", max.	24 V 0.1 V; with 10 kOhm load	24 V 0.1 V; with 10 kOhm load			
• for signal "1", min.	20 V DC	20 V DC			

Technical specifications (continued)

	6ES7 222-1BF32-0XB0 SM 1222 DQ 8x24 VDC	6ES7 222-1BH32-0XB0 SM 1222 DQ 16x24 VDC	6ES7 222-1HF32-0XB0 SM 1222 DQ 8xRelay	6ES7 222-1HH32-0XB0 SM 1222 DQ 16xRelay	6ES7 222-1XF32-0XB0 SM 1222 DQ 8x relay changeover contact
Output current					
• for signal "1" rated value	0.5 A	0.5 A	2 A	2 A	2 A
• for signal "1" permissible range, max.					
• for signal "0" residual current, max.	10 µA	10 µA			
Output delay with resistive load					
• "0" to "1", max.	50 µs	50 µs	10 ms	10 ms	10 ms
• "1" to "0", max.	200 µs	200 µs	10 ms	10 ms	10 ms
Aggregate current of outputs (per group)					
• horizontal installation					
- up to 50 °C, max.	4 A; Current per mass	8 A	10 A	10 A	2 A; Current per mass
Relay outputs					
• Number of relay outputs			8	16	8
• Rated input voltage of relay coil L+ (DC)			24 V	24 V	24 V
• Number of operating cycles, max.			mechanically 10 million, at rated load voltage 100,000	mechanically 10 million, at rated load voltage 100,000	mechanically 10 million, at rated load voltage 100,000
• Switching capacity of contacts					
- with inductive load, max.	0.5 A	0.5 A	2 A	2 A	2 A
- on lamp load, max.	5 W	5 W			
- Switching frequency/contacts/at ohmic load/maximum	0.5 A	0.5 A	2 A	2 A	2 A
Cable length					
• Cable length, shielded, max.	500 m	500 m	500 m	500 m	500 m
• Cable length unshielded, max.	150 m	150 m	150 m	150 m	150 m
Interrupts/diagnostics/ status information					
Alarms					
• Alarms	Yes	Yes	Yes	Yes	Yes
• Diagnostic alarm	Yes	Yes	Yes	Yes	Yes
Diagnostic messages					
• Diagnostic functions	Yes	Yes	Yes	Yes	Yes
• Monitoring the supply voltage	Yes	Yes	Yes	Yes	
Diagnostics indication LED					
• For status of the outputs	Yes	Yes	Yes	Yes	Yes
• for maintenance	Yes	Yes	Yes	Yes	Yes
• Status indicator digital output (green)	Yes	Yes	Yes	Yes	Yes
Galvanic isolation					
Galvanic isolation digital outputs					
• between the channels			Relay	Relay	Relay
• between the channels, in groups of	1	1	2	4	1
• between the channels and the backplane bus	500 V AC	500 V AC	1500 V AC for 1 minute	1500 V AC for 1 minute	1500 V A C for 1 minute
Permissible potential difference between different circuits			750 V AC for 1 minute	750 V AC for 1 minute	750 V AC for 1 minute

SIMATIC S7-1200

Digital modules

SM 1222 digital output modules

Technical specifications (continued)

	6ES7 222-1BF32-0XB0 SM 1222 DQ 8x24 VDC	6ES7 222-1BH32-0XB0 SM 1222 DQ 16x24 VDC	6ES7 222-1HF32-0XB0 SM 1222 DQ 8xRelay	6ES7 222-1HH32-0XB0 SM 1222 DQ 16xRelay	6ES7 222-1XF32-0XB0 SM 1222 DQ 8x relay changeover contact
Degree and class of protection					
IP20	Yes	Yes	Yes	Yes	Yes
Standards, approvals, certificates					
CE mark	Yes	Yes	Yes	Yes	Yes
CSA approval	Yes	Yes	Yes	Yes	Yes
C-TICK	Yes	Yes	Yes	Yes	Yes
FM approval	Yes	Yes	Yes	Yes	Yes
Marine approval	Yes	Yes	Yes	Yes	Yes
Climatic and mechanical conditions for storage and transport					
Climatic conditions for storage and transport					
• Free fall					
- Drop height, max. (in packaging)	0.3 m; five times, in dispatch package	0.3 m; five times, in dispatch package	0.3 m; five times, in dispatch package	0.3 m; five times, in dispatch package	0.3 m; five times, in dispatch package
• Temperature					
- Permissible temperature range	-40 °C to +70 °C	-40 °C to +70 °C	-40 °C to +70 °C	-40 °C to +70 °C	-40 °C to +70 °C
• Air pressure acc. to IEC 60068-2-13					
- Permissible air pressure	1080 to 660 hPa	1080 to 660 hPa	1080 to 660 hPa	1080 to 660 hPa	1080 to 660 hPa
Mechanical and climatic conditions during operation					
Climatic conditions in operation					
• Temperature					
- Min.	-20 °C	-20 °C	-20 °C	-20 °C	-20 °C
- max.	60 °C	60 °C	60 °C	60 °C	60 °C
- Permissible temperature change	5°C to 55°C, 3°C / minute	5°C to 55°C, 3°C / minute	5°C to 55°C, 3°C / minute	5°C to 55°C, 3°C / minute	5°C to 55°C, 3°C / minute
Connection method					
required front connector	Yes	Yes	Yes	Yes	Yes
Mechanics/material					
Type of housing (front)					
• Plastic	Yes	Yes	Yes	Yes	Yes
Dimensions					
Width	45 mm	45 mm	45 mm	45 mm	45 mm
Height	100 mm	100 mm	100 mm	100 mm	100 mm
Depth	75 mm	75 mm	75 mm	75 mm	75 mm
Weight					
Weight, approx.	180 g	220 g	190 g	260 g	310 g

Ordering data	Order No.		Order No.
SM 1222 digital output signal module 8 outputs, 24 V DC; 0.5 A, 5 W, isolated 16 outputs, 24 V DC; 0.5 A, 5 W, isolated 8 relay outputs, 5 ... 30 V DC / 5 ... 250 V AC, 2 A, 30 W DC / 200 W AC 8 relay outputs, change-over contact, 5 ... 30 V DC / 5 ... 250 V AC, 2 A, 30 W DC / 200 W AC 16 relay outputs, 5 ... 30 V DC / 5 ... 250 V AC, 2 A, 30 W DC / 200 W AC	6ES7 222-1BF32-0XB0 6ES7 222-1BH32-0XB0 6ES7 222-1HF32-0XB0 6ES7 222-1XF32-0XB0 6ES7 222-1HH32-0XB0	Terminal block (spare part) for 8/16-channel digital signal modules with 7 screws, tin-plated; 4 pcs. Front flap set (spare part) for 8/16-channel signal modules S7-1200 automation system, System Manual for SIMATIC S7-1200 and STEP 7 Basic German English French Spanish Italian Chinese S7-1200 automation system, Easy Book Brief instructions German English French Spanish Italian Chinese	6ES7 292-1AG30-0XA0 6ES7 291-1BA30-0XA0 6ES7 298-8FA30-8AH0 6ES7 298-8FA30-8BH0 6ES7 298-8FA30-8CH0 6ES7 298-8FA30-8DH0 6ES7 298-8FA30-8EH0 6ES7 298-8FA30-8KH0 6ES7 298-8FA30-8AQ0 6ES7 298-8FA30-8BQ0 6ES7 298-8FA30-8CQ0 6ES7 298-8FA30-8DQ0 6ES7 298-8FA30-8EQ0 6ES7 298-8FA30-8KQ0
Extension cable for two-tier configuration for connecting digital/analog signal modules; length 2 m	6ES7 290-6AA30-0XA0		

SIMATIC S7-1200

Digital modules

SB 1222 digital output modules

Overview



- Digital outputs as a supplement to the integral I/O of SIMATIC S7-1200 CPUs
- Can be plugged directly into the CPU

3

Technical specifications

	6ES7 222-1AD30-0XB0 SB 1222 4xDQ 5VDC 200kHz	6ES7 222-1BD30-0XB0 SB 1222 4xDQ 24VDC 200kHz
Input current from backplane bus 5 V DC, typ.	50 mA	50 mA
Output voltage Power supply to the transmitters • Supply current, max.	4 mA; per channel	4 mA; per channel
Power losses Power loss, typ.	1 W	1 W
Digital outputs Number/binary outputs • In groups of	4; MOSFET, solid-state (current-sinking/current-sourcing) 1	4; MOSFET, solid-state (current-sinking/current-sourcing) 1
Functionality/short-circuit strength	No	No
Switching capacity of the outputs • with resistive load, max.	0.1 A	0.1 A
Load resistance range • upper limit	5 Ω	10 Ω
Output voltage • Rated value (DC) • for signal "0", max. • for signal "1", min. • for signal "1", max.	5 V 0.4 V L+ (-0.5 V) 6 V	24 V 0.1 V; with 10 kOhm load 20 V
Output current • for signal "1" rated value • for signal "1" permissible range, max. • for signal "0" residual current, max.	0.1 A 0.11 A	0.1 A 10 μA
Cable length • Cable length, shielded, max.	50 m	50 m

Technical specifications (continued)

	6ES7 222-1AD30-0XB0 SB 1222 4xDQ 5VDC 200kHz	6ES7 222-1BD30-0XB0 SB 1222 4xDQ 24VDC 200kHz
Interrupts/diagnostics /status information		
Alarms		
• Alarms	Yes	Yes
Diagnostic messages		
• Diagnostic functions	Yes	Yes
Diagnostics indication LED		
• For status of the outputs	Yes	Yes
Degree and class of protection		
IP20	Yes	Yes
Standards, approvals, certificates		
Marine approval according to Germanischer Lloyd	Yes	Yes
Climatic and mechanical conditions for storage and transport		
Climatic conditions for storage and transport		
• Free fall		
- Drop height, max. (in packaging)	0.3 m; five times, in dispatch package	0.3 m; five times, in dispatch package
• Temperature		
- Permissible temperature range	-40 °C to +70 °C	-40 °C to +70 °C
• Air pressure acc. to IEC 60068-2-13		
- Permissible air pressure	1080 to 660 hPa	1080 to 660 hPa
Mechanical and climatic conditions during operation		
Climatic conditions in operation		
• Temperature		
- Permissible temperature range	0 °C to 55 °C horizontal installation 0 °C to 45 °C vertical installation	0 °C to 55 °C horizontal installation 0 °C to 45 °C vertical installation
Mechanics/material		
Type of housing (front)		
• Plastic	Yes	Yes
Dimensions		
Width	38 mm	38 mm
Height	62 mm	62 mm
Depth	21 mm	21 mm
Weight		
Weight, approx.	40 g	40 g

SIMATIC S7-1200

Digital modules

SB 1222 digital output modules

Ordering data

Order No.

SB 1222 digital output signal boards

4 outputs, 5 V DC, 0.1 A, 200 kHz

6ES7 222-1AD30-0XB0

4 outputs, 24 V DC, 0.1 A, 200 kHz

6ES7 222-1BD30-0XB0

Terminal block (spare part)

for signal board

with 6 screws, gold-plated; 4 pcs.

6ES7 292-1BF30-0XA0

S7-1200 automation system, System Manual

for SIMATIC S7-1200 and
STEP 7 Basic

German

6ES7 298-8FA30-8AH0

English

6ES7 298-8FA30-8BH0

French

6ES7 298-8FA30-8CH0

Spanish

6ES7 298-8FA30-8DH0

Italian

6ES7 298-8FA30-8EH0

Chinese

6ES7 298-8FA30-8KH0

Order No.

S7-1200 automation system, Easy Book

Brief instructions

German

6ES7 298-8FA30-8AQ0

English

6ES7 298-8FA30-8BQ0

French

6ES7 298-8FA30-8CQ0

Spanish

6ES7 298-8FA30-8DQ0

Italian

6ES7 298-8FA30-8EQ0

Chinese

6ES7 298-8FA30-8KQ0

3

Overview



- Digital inputs and outputs as supplement to the integral I/O of the CPUs
- For flexible adaptation of the controller to the relevant task
- For subsequent expansion of the system with additional inputs and outputs

Technical specifications

	6ES7 223-1BH32-0XB0 SM 1223 DI 8x24 VDC, DQ 8x24 VDC	6ES7 223-1BL32-0XB0 SM 1223 DI 16x24 VDC, DQ 16x24 VDC	6ES7 223-1PH32-0XB0 SM 1223 DI 8x24 VDC, DQ 8xRelay	6ES7 223-1PL32-0XB0 SM 1223 DI 16x24 VDC, DQ 16xRelay	6ES7 223-1QH32-0XB0 SM 223 120/230 V AC DIx8/DQx8 RLY
Supply voltage 24 V DC	Yes	Yes	Yes	Yes	Yes
permissible range, lower limit (DC)		20.4 V			20.4 V
permissible range, upper limit (DC)	28.8 V	28.8 V	28.8 V	28.8 V	28.8 V
Input current from backplane bus 5 V DC, max.	145 mA	185 mA	145 mA	180 mA	120 mA
Digital inputs • from load voltage L+ (without load), max.	4 mA; per channel	4 mA; per channel	4 mA/input 11 mA/relay	4 mA/input 11 mA/relay	
Output voltage Power supply to the transmitters • present	Yes	Yes	Yes	Yes	Yes
Power losses Power loss, typ.	2.5 W	4.5 W	5.5 W	10 W	7.5 W
Digital inputs Number/binary inputs • In groups of	8 2	16 2	8 2	16 2	8 4
Input characteristic curve acc. to IEC 61131, Type 1	Yes	Yes	Yes	Yes	Yes
Number of simultaneously controllable inputs • all mounting positions - up to 40 °C, max.	8	16	8	16	8
• horizontal installation - up to 40 °C, max.	8	16	8	16	8
- up to 50 °C, max.	8	16	8	16	8
• vertical installation - up to 40 °C, max.	8	16	8	16	8

SIMATIC S7-1200

Digital modules

SM 1223 digital input/output modules

Technical specifications (continued)

	6ES7 223-1BH32-0XB0 SM 1223 DI 8x24 VDC, DQ 8x24 VDC	6ES7 223-1BL32-0XB0 SM 1223 DI 16x24 VDC, DQ 16x24 VDC	6ES7 223-1PH32-0XB0 SM 1223 DI 8x24 VDC, DQ 8xRelay	6ES7 223-1PL32-0XB0 SM 1223 DI 16x24 VDC, DQ 16xRelay	6ES7 223-1QH32-0XB0 SM 223 120/230 V AC DIx8/DQx8 RLY
Input voltage • Type of input voltage • Rated value, DC • for signal "0" • for signal "1"	24 V	DC 24 V 5 V DC at 1 mA 15 V DC at 2.5 mA	24 V	24 V	AC
Input current • for signal "0", max. (permissible quiescent current) • for signal "1", min. • for signal "1", typ.	1 mA 2.5 mA 4 mA; Typical	1 mA 2.5 mA 4 mA; Typical	1 mA 2.5 mA 4 mA; Typical	1 mA 2.5 mA 4 mA; Typical	1 mA 2.5 mA 9 mA; Typical
Input delay (for rated value of input voltage) • for standard inputs - Parameterizable • for interrupt inputs - Parameterizable	 Yes; 0.2, 0.4, 0.8, 1.6, 3.2, 6.4, and 12.8 ms, selectable in groups of four Yes	 Yes; 0.2, 0.4, 0.8, 1.6, 3.2, 6.4, and 12.8 ms, selectable in groups of four Yes	 Yes; 0.2, 0.4, 0.8, 1.6, 3.2, 6.4, and 12.8 ms, selectable in groups of four Yes	 Yes; 0.2, 0.4, 0.8, 1.6, 3.2, 6.4, and 12.8 ms, selectable in groups of four Yes	 Yes; 0.2, 0.4, 0.8, 1.6, 3.2, 6.4, and 12.8 ms, selectable in groups of four Yes
Cable length • Cable length, shielded, max. • Cable length unshielded, max.	500 m 300 m	500 m 300 m	500 m 300 m	500 m 300 m	500 m 300 m
Digital outputs Number/binary outputs • In groups of	8 1	16 1	8 2	16 4	8 4
Functionality/short-circuit strength	No; to be provided externally	No; to be provided externally	No; to be provided externally	No; to be provided externally	No; to be provided externally
Limitation of inductive shutdown voltage to	L+ (-48 V)	L+ (-48 V)			
Switching capacity of the outputs • with resistive load, max. • on lamp load, max.	0.5 A 5 W	0.5 A 5 W	2 A	2 A	2 A
Output voltage • Rated value (DC) • for signal "0", max. • for signal "1", min.	24 V 0.1 V; with 10 kOhm load 20 V DC	24 V 0.1 V; with 10 kOhm load 20 V DC			
Output current • for signal "1" permissible range, max. • for signal "0" residual current, max.	0.5 A 10 µA	0.5 A 10 µA	2 A	2 A	2 A
Output delay with resistive load • "0" to "1", max. • "1" to "0", max.	50 µs 200 µs	50 µs 200 µs	10 ms 10 ms	10 ms 10 ms	10 ms 10 ms
Aggregate current of outputs (per group) • horizontal installation - up to 50 °C, max.	4 A; Current per mass	8 A; Current per mass	10 A; Current per mass	8 A; Current per mass	8 A; Current per mass

Technical specifications (continued)

	6ES7 223-1BH32-0XB0 SM 1223 DI 8x24 VDC, DQ 8x24 VDC	6ES7 223-1BL32-0XB0 SM 1223 DI 16x24 VDC, DQ 16x24 VDC	6ES7 223-1PH32-0XB0 SM 1223 DI 8x24 VDC, DQ 8xRelay	6ES7 223-1PL32-0XB0 SM 1223 DI 16x24 VDC, DQ 16xRelay	6ES7 223-1QH32-0XB0 SM 223 120/230 V AC DIx8/DQx8 RLY
Relay outputs					
• Number of relay outputs			8	16	8
• Rated input voltage of relay coil L+ (DC)			24 V	24 V	24 V
• Number of operating cycles, max.			mechanically 10 million, at rated load voltage 100,000	mechanically 10 million, at rated load voltage 100,000	mechanically 10 million, at rated load voltage 100,000
• Switching capacity of contacts					
- with inductive load, max.	0.5 A	0.5 A	2 A	2 A	2 A
- on lamp load, max.	5 W	5 W			
- Switching frequency/contacts/ at ohmic load/maximum	0.5 A	0.5 A	2 A	2 A	2 A
Cable length					
• Cable length, shielded, max.	500 m	500 m	500 m	500 m	500 m
• Cable length unshielded, max.	150 m	150 m	150 m	150 m	150 m
Interrupts/diagnostics/ status information					
Alarms					
• Alarms	Yes	Yes	Yes	Yes	Yes
• Diagnostic alarm	Yes	Yes	Yes	Yes	Yes
Diagnostic messages					
• Diagnostic functions	Yes	Yes	Yes	Yes	Yes
• Monitoring the supply voltage	Yes		Yes	Yes	
Diagnostics indication LED					
• for status of the inputs	Yes	Yes	Yes	Yes	Yes
• For status of the outputs	Yes	Yes	Yes	Yes	Yes
• for maintenance	Yes	Yes	Yes	Yes	Yes
• Status indicator digital output (green)	Yes	Yes	Yes	Yes	Yes
• Status indicator digital input (green)	Yes	Yes	Yes	Yes	Yes
Galvanic isolation					
Galvanic isolation digital inputs					
• between the channels, in groups of	2	2	2	2	2
Galvanic isolation digital outputs					
• between the channels			Relay	Relay	Relay
• between the channels, in groups of	1	1	2	4	2
• between the channels and the backplane bus	500 V AC	500 V AC	1500 V AC for 1 minute	1500 V AC for 1 minute	1500 V AC for 1 minute
Permissible potential difference					
between different circuits			750 V AC for 1 minute	750 V AC for 1 minute	750 V AC for 1 minute
Degree and class of protection					
IP20	Yes	Yes	Yes	Yes	Yes
Standards, approvals, certificates					
CE mark	Yes	Yes	Yes	Yes	Yes
CSA approval	Yes		Yes	Yes	Yes
C-TICK	Yes	Yes	Yes	Yes	Yes
FM approval	Yes	Yes	Yes	Yes	Yes
Marine approval	Yes		Yes	Yes	Yes

SIMATIC S7-1200

Digital modules

SM 1223 digital input/output modules

Technical specifications (continued)

	6ES7 223-1BH32-0XB0 SM 1223 DI 8x24 VDC, DQ 8x24 VDC	6ES7 223-1BL32-0XB0 SM 1223 DI 16x24 VDC, DQ 16x24 VDC	6ES7 223-1PH32-0XB0 SM 1223 DI 8x24 VDC, DQ 8xRelay	6ES7 223-1PL32-0XB0 SM 1223 DI 16x24 VDC, DQ 16xRelay	6ES7 223-1QH32-0XB0 SM 223 120/230 V AC DIx8/DQx8 RLY
Climatic and mechanical conditions for storage and transport Climatic conditions for storage and transport					
• Free fall - Drop height, max. (in packaging)	0.3 m; five times, in dispatch package	0.3 m; five times, in dispatch package	0.3 m; five times, in dispatch package	0.3 m; five times, in dispatch package	0.3 m; five times, in dispatch package
• Temperature - Permissible temperature range	-40 °C to +70 °C	-40 °C to +70 °C	-40 °C to +70 °C	-40 °C to +70 °C	-40 °C to +70 °C
• Air pressure acc. to IEC 60068-2-13 - Permissible air pressure	1080 to 660 hPa	1080 to 660 hPa	1080 to 660 hPa	1080 to 660 hPa	1080 to 660 hPa
Mechanical and climatic conditions during operation Climatic conditions in operation					
• Temperature - Min.	-20 °C	-20 °C	-20 °C	-20 °C	-20 °C
- Max.	60 °C	60 °C	60 °C	60 °C	60 °C
- Permissible temperature change	5°C to 55°C, 3°C / minute	5°C to 55°C, 3°C / minute	5°C to 55°C, 3°C / minute	5°C to 55°C, 3°C / minute	5°C to 55°C, 3°C / minute
Connection method required front connector	Yes	Yes	Yes	Yes	Yes
Mechanics/material Type of housing (front)					
• Plastic	Yes	Yes	Yes	Yes	Yes
Dimensions					
Width	45 mm	70 mm	45 mm	70 mm	45 mm
Height	100 mm	100 mm	100 mm	100 mm	100 mm
Depth	75 mm	75 mm	75 mm	75 mm	75 mm
Weight Weight, approx.	210 g	310 g	230 g	350 g	230 g

3

Ordering data	Order No.	Order No.
SM 1223 digital input/output signal module 8 inputs, 24 V DC, IEC type 1 current sinking; 8 24 V DC transistor outputs, 0.5 A, 5 W 16 inputs, 24 V DC, IEC type 1 current sinking; 16 24 V DC transistor outputs, 0.5 A, 5 W 8 inputs, 24 V DC, IEC type 1 current sinking; 8 relay outputs, 5 ... 30 V DC/ 5 ... 250 V AC, 2 A, 30 W DC/ 200 W AC 16 inputs, 24 V DC, IEC type 1 current sinking; 16 relay outputs, 5 ... 30 V DC/ 5 ... 250 V AC, 2 A, 30 W DC/ 200 W AC 8 inputs, 120/230 V AC; 8 relay outputs, 5 ... 30 V DC/ 5 ... 250 V AC, 2 A, 30 W DC/ 200 W AC	6ES7 223-1BH32-0XB0 6ES7 223-1BL32-0XB0 6ES7 223-1PH32-0XB0 6ES7 223-1PL32-0XB0 6ES7 223-1QH32-0XB0	Front flap set (spare part) for 8/16-channel signal modules for 32-channel signal modules S7-1200 automation system, System Manual for SIMATIC S7-1200 and STEP 7 Basic German English French Spanish Italian Chinese S7-1200 automation system, Easy Book Brief instructions German English French Spanish Italian Chinese
Extension cable for two-tier configuration for connecting digital/analog signal modules; length 2 m	6ES7 290-6AA30-0XA0	6ES7 291-1BA30-0XA0 6ES7 291-1BB30-0XA0 6ES7 298-8FA30-8AH0 6ES7 298-8FA30-8BH0 6ES7 298-8FA30-8CH0 6ES7 298-8FA30-8DH0 6ES7 298-8FA30-8EH0 6ES7 298-8FA30-8KH0 6ES7 298-8FA30-8AQ0 6ES7 298-8FA30-8BQ0 6ES7 298-8FA30-8CQ0 6ES7 298-8FA30-8DQ0 6ES7 298-8FA30-8EQ0 6ES7 298-8FA30-8KQ0
Terminal block (spare part) for 8/16-channel digital signal modules with 7 screws, tin-plated; 4 pcs.	6ES7 292-1AG40-0XA0	

SIMATIC S7-1200

Digital modules

SB 1223 digital input/output modules

Overview



- Digital inputs and outputs as supplement to the integral I/O of the SIMATIC S7-1200 CPUs
- Can be plugged direct into the CPU

Technical specifications

	6ES7 223-0BD30-0XB0 SB 1223 DI2x24 VDC, DQ 2x24 VDC	6ES7 223-3AD30-0XB0 SB 1223 2xDI / 2xDQ 5VDC 200kHz	6ES7 223-3BD30-0XB0 SB 1223 2xDI / 2xDQ 24VDC 200kHz
Supply voltage			
permissible range, lower limit (DC)	20.4 V		
permissible range, upper limit (DC)	30 V		
Input current			
from backplane bus 5 V DC, typ.	50 mA	50 mA	50 mA
Output voltage			
Power supply to the transmitters			
• Supply current, max.	4 mA; per channel	4 mA; per channel	4 mA; per channel
Power losses			
Power loss, typ.	1 W	1 W	1 W
Digital inputs			
Number/binary inputs	2; Current-sinking	2; Current-sourcing	2; Current-sourcing
• In groups of	1	1	1
Input characteristic curve acc. to IEC 61131, Type 1	Yes	Yes	Yes
Number of simultaneously controllable inputs			
• all mounting positions - up to 40 °C, max.	2	2	2
Input voltage			
• Type of input voltage	DC		
• Rated value, DC	24 V	5 V	24 V
• for signal "0"	0 to 5 V	0 to 1 V	0 to 5 V
• for signal "1"	15 to 30 V	2 to 6 V	15 to 30 V
Input current			
• for signal "0", max. (permissible quiescent current)	1 mA	3 mA	2 mA
• for signal "1", min.		6 mA	5.8 mA
• for signal "1", typ.	0.5 A		14 mA

Technical specifications (continued)

	6ES7 223-0BD30-0XB0 SB 1223 DI2x24 VDC, DQ 2x24 VDC	6ES7 223-3AD30-0XB0 SB 1223 2xDI / 2xDQ 5VDC 200kHz	6ES7 223-3BD30-0XB0 SB 1223 2xDI / 2xDQ 24VDC 200kHz
Input delay (for rated value of input voltage)			
• for standard inputs			
- Parameterizable	Yes; 0.2, 0.4, 0.8, 1.6, 3.2, 6.4, and 12.8 ms, selectable in groups of four	Yes; 0.2, 0.4, 0.8, 1.6, 3.2, 6.4, and 12.8 ms, selectable in groups of four	Yes; 0.2, 0.4, 0.8, 1.6, 3.2, 6.4, and 12.8 ms, selectable in groups of four
- at "0" to "1", max.	2 µs	2 µs	2.5 µs
- at "1" to "0", max.	10 µs		
• for interrupt inputs			
- Parameterizable	Yes	Yes	Yes
• for counter/technological functions			
- Parameterizable	Yes	Yes	Yes
Cable length			
• Cable length, shielded, max.	500 m	50 m	Standard input: 500 m, high-speed counters: 50 m
• Cable length unshielded, max.	300 m		
Digital outputs			
Number/binary outputs	2; MOSFET, solid-state (current-sinking/current-sourcing)	2; MOSFET, solid-state (current-sinking/current-sourcing)	2; MOSFET, solid-state (current-sinking/current-sourcing)
• In groups of	1	1	1
Functionality/short-circuit strength	No	No	No
Switching capacity of the outputs			
• with resistive load, max.	0.5 A	0.1 A	0.1 A
• on lamp load, max.	5 W		
Load resistance range			
• upper limit	0.6 Ω	5 Ω	10 Ω
Output voltage			
• Rated value (DC)	24 V	5 V	24 V
• for signal "0", max.	0.1 V; with 10 kOhm load	0.4 V	0.1 V; with 10 kOhm load
• for signal "1", min.	20 V	L+ (-0.5 V)	20 V
• for signal "1", max.		6 V	
Output current			
• for signal "1" rated value	0.5 A	0.1 A	0.1 A
• for signal "1" permissible range, max.		0.11 A	
• for signal "0" residual current, max.	10 µA		10 µA
Cable length			
• Cable length, shielded, max.	500 m	50 m	50 m
• Cable length unshielded, max.	150 m		
Interrupts/diagnostics/ status information			
Alarms			
• Alarms	Yes	Yes	Yes
Diagnostic messages			
• Diagnostic functions	Yes	Yes	Yes
Diagnostics indication LED			
• for status of the inputs	Yes	Yes	Yes
• For status of the outputs	Yes	Yes	Yes
Degree and class of protection			
IP20	Yes	Yes	Yes
Standards, approvals, certificates			
Marine approval according to Germanischer Lloyd	Yes	Yes	Yes

SIMATIC S7-1200

Digital modules

SB 1223 digital input/output modules

Technical specifications (continued)

	6ES7 223-0BD30-0XB0 SB 1223 DI2x24 VDC, DQ 2x24 VDC	6ES7 223-3AD30-0XB0 SB 1223 2xDI / 2xDQ 5VDC 200kHz	6ES7 223-3BD30-0XB0 SB 1223 2xDI / 2xDQ 24VDC 200kHz
Climatic and mechanical conditions for storage and transport			
Climatic conditions for storage and transport			
• Free fall			
- Drop height, max. (in packaging)	0.3 m; five times, in dispatch package	0.3 m; five times, in dispatch package	0.3 m; five times, in dispatch package
• Temperature			
- Permissible temperature range	-40 °C to +70 °C	-40 °C to +70 °C	-40 °C to +70 °C
• Air pressure acc. to IEC 60068-2-13			
- Permissible air pressure	1080 to 660 hPa	1080 to 660 hPa	1080 to 660 hPa
Mechanical and climatic conditions during operation			
Climatic conditions in operation			
• Temperature			
- Permissible temperature range	0 °C to 55 °C horizontal installation 0 °C to 45 °C vertical installation	0 °C to 55 °C horizontal installation 0 °C to 45 °C vertical installation	0 °C to 55 °C horizontal installation 0 °C to 45 °C vertical installation
Mechanics/material			
Type of housing (front)			
• Plastic	Yes	Yes	Yes
Dimensions			
Width	38 mm	38 mm	38 mm
Height	62 mm	62 mm	62 mm
Depth	21 mm	21 mm	21 mm
Weight			
Weight, approx.	40 g	40 g	40 g

Ordering data

SB 1223 digital input/output signal boards

2 inputs, 24 V DC, IEC type 1 current sinking; 2 24 V DC transistor outputs, 0.5 A, 5 W; can be used as HSC at up to 30 kHz

6ES7 223-0BD30-0XB0

2 inputs, 5 V DC, 200 kHz
2 outputs 5 V DC, 0.1 A, 200 kHz

6ES7 223-3AD30-0XB0

2 inputs, 24 V DC, 200 kHz
2 outputs 24 V DC, 0.1 A, 200 kHz

6ES7 223-3BD30-0XB0

Terminal block (spare part)

for signal board
with 6 screws, gold-plated; 4 pcs.

6ES7 292-1BF30-0XA0

S7-1200 automation system, System Manual

for SIMATIC S7-1200 and STEP 7 Basic

German

6ES7 298-8FA30-8AH0

English

6ES7 298-8FA30-8BH0

French

6ES7 298-8FA30-8CH0

Spanish

6ES7 298-8FA30-8DH0

Italian

6ES7 298-8FA30-8EH0

Chinese

6ES7 298-8FA30-8KH0

S7-1200 automation system, Easy Book

Brief instructions

German

6ES7 298-8FA30-8AQ0

English

6ES7 298-8FA30-8BQ0

French

6ES7 298-8FA30-8CQ0

Spanish

6ES7 298-8FA30-8DQ0

Italian

6ES7 298-8FA30-8EQ0

Chinese

6ES7 298-8FA30-8KQ0

Overview



- Digital inputs as supplement to the integral I/O of the CPUs
- For flexible adaptation of the controller to the corresponding task
- For subsequent expansion of the system with additional inputs
- From +60 °C to +70 °C, max. 50% of the inputs can be controlled simultaneously

Note:

SIPLUS extreme products are based on Siemens Industry standard products. The contents listed here were taken from the respective standard products. SIPLUS extreme-specific information was added.

3

Technical specifications

The technical data correspond to those of the based-on modules apart from the values listed in the table.

	6AG1 221-1BF30-2XB0 SM 1221 DI 8x24 VDC	6AG1 221-1BF30-4XB0 SM 1221 DI 8x24 VDC	6AG1 221-1BH30-2XB0 SM 1221 DI 16x24 VDC	6AG1 221-1BH30-4XB0 SM 1221 DI 16x24 VDC
Based on	6ES7 221-1BF30-0XB0	6ES7 221-1BF30-0XB0	6ES7 221-1BH30-0XB0	6ES7 221-1BH30-0XB0
Ambient conditions				
Extended ambient conditions				
• Relative to ambient temperature-atmospheric pressure-installation altitude	Tmin ... Tmax at 1080 hPa ... 795 hPa (-1000 m ... +2000 m) // Tmin ... (Tmax - 10K) at 795 hPa ... 658 hPa (+2000 m ... +3500 m) // Tmin ... (Tmax - 20K) at 658 hPa ... 540 hPa (+3500 m ... +5000 m)	Tmin ... Tmax at 1080 hPa ... 795 hPa (-1000 m ... +2000 m) // Tmin ... (Tmax - 10K) at 795 hPa ... 658 hPa (+2000 m ... +3500 m) // Tmin ... (Tmax - 20K) at 658 hPa ... 540 hPa (+3500 m ... +5000 m)	Tmin ... Tmax at 1080 hPa ... 795 hPa (-1000 m ... +2000 m) // Tmin ... (Tmax - 10K) at 795 hPa ... 658 hPa (+2000 m ... +3500 m) // Tmin ... (Tmax - 20K) at 658 hPa ... 540 hPa (+3500 m ... +5000 m)	Tmin ... Tmax at 1080 hPa ... 795 hPa (-1000 m ... +2000 m) // Tmin ... (Tmax - 10K) at 795 hPa ... 658 hPa (+2000 m ... +3500 m) // Tmin ... (Tmax - 20K) at 658 hPa ... 540 hPa (+3500 m ... +5000 m)
• Relative humidity - with condensation	100 %; Relative humidity, incl. condensation / frost permitted (no commissioning under condensation conditions)	100 %; Relative humidity, incl. condensation / frost permitted (no commissioning under condensation conditions)	100 %; Relative humidity, incl. condensation / frost permitted (no commissioning under condensation conditions)	100 %; Relative humidity, incl. condensation / frost permitted (no commissioning under condensation conditions)
• Resistance - to biologically active substances	Yes; Class 3B2 mold, fungus and dry rot spores (with the exception of fauna). The supplied connector covers must remain on the unused interfaces during operation!	Yes; Class 3B2 mold, fungus and dry rot spores (with the exception of fauna). The supplied connector covers must remain on the unused interfaces during operation!	Yes; Class 3B2 mold, fungus and dry rot spores (with the exception of fauna). The supplied connector covers must remain on the unused interfaces during operation!	Yes; Class 3B2 mold, fungus and dry rot spores (with the exception of fauna). The supplied connector covers must remain on the unused interfaces during operation!
- to chemically active substances	Yes; Class 3C4 incl. salt spray according to EN 60068-2-52 (degree of severity 3). The supplied connector covers must remain on the unused interfaces during operation!	Yes; Class 3C4 incl. salt spray according to EN 60068-2-52 (degree of severity 3). The supplied connector covers must remain on the unused interfaces during operation!	Yes; Class 3C4 incl. salt spray according to EN 60068-2-52 (degree of severity 3). The supplied connector covers must remain on the unused interfaces during operation!	Yes; Class 3C4 incl. salt spray according to EN 60068-2-52 (degree of severity 3). The supplied connector covers must remain on the unused interfaces during operation!
- to mechanically active substances	Yes; Class 3S4 incl. sand, dust. The supplied connector covers must remain on the unused interfaces during operation!	Yes; Class 3S4 incl. sand, dust. The supplied connector covers must remain on the unused interfaces during operation!	Yes; Class 3S4 incl. sand, dust. The supplied connector covers must remain on the unused interfaces during operation!	Yes; Class 3S4 incl. sand, dust. The supplied connector covers must remain on the unused interfaces during operation!

SIMATIC S7-1200

SIPLUS digital modules

SIPLUS SM 1221 digital input modules

Technical specifications (continued)

	6AG1 221-1BF30-2XB0 SM 1221 DI 8x24 VDC	6AG1 221-1BF30-4XB0 SM 1221 DI 8x24 VDC	6AG1 221-1BH30-2XB0 SM 1221 DI 16x24 VDC	6AG1 221-1BH30-4XB0 SM 1221 DI 16x24 VDC
Based on	6ES7 221-1BF30-0XB0	6ES7 221-1BF30-0XB0	6ES7 221-1BH30-0XB0	6ES7 221-1BH30-0XB0
Climatic and mechanical conditions for storage and transport				
Climatic conditions for storage and transport				
• Free fall				
- Drop height, max. (in packaging)	0.3 m; five times, in dispatch package	0.3 m; five times, in dispatch package	0.3 m; five times, in dispatch package	0.3 m; five times, in dispatch package
• Temperature				
- Permissible temperature range	-40 °C to +70 °C	-40 °C to +70 °C	-40 °C to +70 °C	-40 °C to +70 °C
Mechanical and climatic conditions during operation				
Climatic conditions in operation				
• Temperature				
- Min.	-25 °C; = Tmin	0 °C; = Tmin	-25 °C; = Tmin	0 °C; = Tmin
- max.	70 °C; = Tmax	55 °C; = Tmax	70 °C; = Tmax	55 °C; = Tmax
- Permissible temperature change		5°C to 55°C, 3°C / minute		5°C to 55°C, 3°C / minute

Ordering data

SIPLUS SM 1221 digital input signal module

(extended temperature range and medial exposure)

8 inputs, 24 V DC, isolated, current sourcing/sinking

- Suitable for areas with extraordinary medial exposure (conformal coating)
- -25 ... +70 °C, from +60 ... +70 °C number of simultaneously controllable inputs and outputs max. 50 %

16 inputs, 24 V DC, isolated, current sourcing/sinking

- Suitable for areas with extraordinary medial exposure (conformal coating)
- -25 ... +70 °C, from +60 ... +70 °C number of simultaneously controllable inputs and outputs max. 50 %

Order No.

6AG1 221-1BF30-4XB0

6AG1 221-1BF30-2XB0

6AG1 221-1BH30-4XB0

6AG1 221-1BH30-2XB0

Accessories

Order No.

See SIMATIC S7-1200 SM 1221 digital input, page 3/42

Overview



- Digital outputs as a supplement to the integral I/O of the CPUs
- For flexible adaptation of the controller to the corresponding task
- For subsequent expansion of the system with additional outputs
- From +60 °C to +70 °C, max. 50% of the inputs can be controlled simultaneously

Note:

SIPLUS extreme products are based on Siemens Industry standard products. The contents listed here were taken from the respective standard products. SIPLUS extreme-specific information was added.

3

Technical specifications

The technical data correspond to those of the based-on modules apart from the values listed in the table.

	6AG1 222-1BF30-2XB0 SM 1222 DQ 8x24 VDC	6AG1 222-1BF30-4XB0 SM 1222 DQ 8x24 VDC	6AG1 222-1BH30-2XB0 SM 1222 DQ 16x24 VDC	6AG1 222-1BH30-4XB0 SM 1222 DQ 16x24 VDC
Based on	6ES7 222-1BF30-0XB0	6ES7 222-1BF30-0XB0	6ES7 222-1BH30-0XB0	6ES7 222-1BH30-0XB0
Ambient conditions				
Extended ambient conditions				
• Relative to ambient temperature-atmospheric pressure-installation altitude	Tmin ... Tmax at 1080 hPa ... 795 hPa (-1000 m ... +2000 m) // Tmin ... (Tmax - 10K) at 795 hPa ... 658 hPa (+2000 m ... +3500 m) // Tmin ... (Tmax - 20K) at 658 hPa ... 540 hPa (+3500 m ... +5000 m)	Tmin ... Tmax at 1080 hPa ... 795 hPa (-1000 m ... +2000 m) // Tmin ... (Tmax - 10K) at 795 hPa ... 658 hPa (+2000 m ... +3500 m) // Tmin ... (Tmax - 20K) at 658 hPa ... 540 hPa (+3500 m ... +5000 m)	Tmin ... Tmax at 1080 hPa ... 795 hPa (-1000 m ... +2000 m) // Tmin ... (Tmax - 10K) at 795 hPa ... 658 hPa (+2000 m ... +3500 m) // Tmin ... (Tmax - 20K) at 658 hPa ... 540 hPa (+3500 m ... +5000 m)	Tmin ... Tmax at 1080 hPa ... 795 hPa (-1000 m ... +2000 m) // Tmin ... (Tmax - 10K) at 795 hPa ... 658 hPa (+2000 m ... +3500 m) // Tmin ... (Tmax - 20K) at 658 hPa ... 540 hPa (+3500 m ... +5000 m)
• Relative humidity - with condensation	100 %; Relative humidity, incl. condensation / frost permitted (no commissioning under condensation conditions)	100 %; Relative humidity, incl. condensation / frost permitted (no commissioning under condensation conditions)	100 %; Relative humidity, incl. condensation / frost permitted (no commissioning under condensation conditions)	100 %; Relative humidity, incl. condensation / frost permitted (no commissioning under condensation conditions)
• Resistance - to biologically active substances	Yes; Class 3B2 mold, fungus and dry rot spores (with the exception of fauna). The supplied connector covers must remain on the unused interfaces during operation!	Yes; Class 3B2 mold, fungus and dry rot spores (with the exception of fauna). The supplied connector covers must remain on the unused interfaces during operation!	Yes; Class 3B2 mold, fungus and dry rot spores (with the exception of fauna). The supplied connector covers must remain on the unused interfaces during operation!	Yes; Class 3B2 mold, fungus and dry rot spores (with the exception of fauna). The supplied connector covers must remain on the unused interfaces during operation!
- to chemically active substances	Yes	Yes	Yes	Yes
- to mechanically active substances	Yes; Class 3S4 incl. sand, dust. The supplied connector covers must remain on the unused interfaces during operation!	Yes; Class 3S4 incl. sand, dust. The supplied connector covers must remain on the unused interfaces during operation!	Yes; Class 3S4 incl. sand, dust. The supplied connector covers must remain on the unused interfaces during operation!	Yes; Class 3S4 incl. sand, dust. The supplied connector covers must remain on the unused interfaces during operation!

SIMATIC S7-1200

SIPLUS digital modules

SIPLUS SM 1222 digital output modules

Technical specifications (continued)

	6AG1 222-1BF30-2XB0 SM 1222 DQ 8x24 VDC	6AG1 222-1BF30-4XB0 SM 1222 DQ 8x24 VDC	6AG1 222-1BH30-2XB0 SM 1222 DQ 16x24 VDC	6AG1 222-1BH30-4XB0 SM 1222 DQ 16x24 VDC
Based on	6ES7 222-1BF30-0XB0	6ES7 222-1BF30-0XB0	6ES7 222-1BH30-0XB0	6ES7 222-1BH30-0XB0
Climatic and mechanical conditions for storage and transport				
Climatic conditions for storage and transport				
• Free fall				
- Drop height, max. (in packaging)	0.3 m; five times, in dispatch package	0.3 m; five times, in dispatch package	0.3 m; five times, in dispatch package	0.3 m; five times, in dispatch package
• Temperature				
- Permissible temperature range	-40 °C to +70 °C	-40 °C to +70 °C	-40 °C to +70 °C	-40 °C to +70 °C
Mechanical and climatic conditions during operation				
Climatic conditions in operation				
• Temperature				
- Min.	-25 °C; = Tmin	0 °C; = Tmin	-25 °C; = Tmin	0 °C; = Tmin
- max.	70 °C; = Tmax	55 °C; = Tmax	70 °C; = Tmax	55 °C; = Tmax
- Permissible temperature change		5°C to 55°C, 3°C / minute		5°C to 55°C, 3°C / minute
Based on	6AG1 222-1HF30-2XB0 SM 1222 DQ 8xRelay	6AG1 222-1HF30-4XB0 SM 1222 DQ 8xRelay	6AG1 222-1HH30-2XB0 SM 1222 DQ 16xRelay	6AG1 222-1HH30-4XB0 SM 1222 DQ 16xRelay
	6ES7 222-1HF30-0XB0	6ES7 222-1HF30-0XB0	6ES7 222-1HH30-0XB0	6ES7 222-1HH30-0XB0
Ambient conditions				
Extended ambient conditions				
• Relative to ambient temperature-atmospheric pressure-installation altitude	Tmin ... Tmax at 1080 hPa ... 795 hPa (-1000 m ... +2000 m) // Tmin ... (Tmax - 10K) at 795 hPa ... 658 hPa (+2000 m ... +3500 m) // Tmin ... (Tmax - 20K) at 658 hPa ... 540 hPa (+3500 m ... +5000 m)	Tmin ... Tmax at 1080 hPa ... 795 hPa (-1000 m ... +2000 m) // Tmin ... (Tmax - 10K) at 795 hPa ... 658 hPa (+2000 m ... +3500 m) // Tmin ... (Tmax - 20K) at 658 hPa ... 540 hPa (+3500 m ... +5000 m)	Tmin ... Tmax at 1080 hPa ... 795 hPa (-1000 m ... +2000 m) // Tmin ... (Tmax - 10K) at 795 hPa ... 658 hPa (+2000 m ... +3500 m) // Tmin ... (Tmax - 20K) at 658 hPa ... 540 hPa (+3500 m ... +5000 m)	Tmin ... Tmax at 1080 hPa ... 795 hPa (-1000 m ... +2000 m) // Tmin ... (Tmax - 10K) at 795 hPa ... 658 hPa (+2000 m ... +3500 m) // Tmin ... (Tmax - 20K) at 658 hPa ... 540 hPa (+3500 m ... +5000 m)
• Relative humidity				
- with condensation	100 %; Relative humidity, incl. condensation / frost permitted (no commissioning under condensation conditions)	100 %; Relative humidity, incl. condensation / frost permitted (no commissioning under condensation conditions)	100 %; Relative humidity, incl. condensation / frost permitted (no commissioning under condensation conditions)	100 %; Relative humidity, incl. condensation / frost permitted (no commissioning under condensation conditions)
• Resistance				
- to biologically active substances	Yes; Class 3B2 mold, fungus and dry rot spores (with the exception of fauna). The supplied connector covers must remain on the unused interfaces during operation!	Yes; , Class 3B2 mold, fungus and dry rot spores (with the exception of fauna). The supplied connector covers must remain on the unused interfaces during operation!	Yes; Class 3B2 mold, fungus and dry rot spores (with the exception of fauna). The supplied connector covers must remain on the unused interfaces during operation!	Yes; Class 3B2 mold, fungus and dry rot spores (with the exception of fauna). The supplied connector covers must remain on the unused interfaces during operation!
- to chemically active substances	Yes; Class 3C4 incl. salt spray. The supplied connector covers must remain on the unused interfaces during operation!	Yes; , Class 3C4 incl. salt spray. The supplied connector covers must remain on the unused interfaces during operation!	Yes; Class 3C4 incl. salt spray. The supplied connector covers must remain on the unused interfaces during operation!	Yes; Class 3C4 incl. salt spray. The supplied connector covers must remain on the unused interfaces during operation!
- to mechanically active substances	Yes; Class 3S4 incl. sand, dust. The supplied connector covers must remain on the unused interfaces during operation!	Yes; , Class 3S4 incl. sand, dust. The supplied connector covers must remain on the unused interfaces during operation!	Yes; Class 3S4 incl. sand, dust. The supplied connector covers must remain on the unused interfaces during operation!	Yes; Class 3S4 incl. sand, dust. The supplied connector covers must remain on the unused interfaces during operation!

Technical specifications (continued)

	6AG1 222-1HF30-2XB0 SM 1222 DQ 8xRelay	6AG1 222-1HF30-4XB0 SM 1222 DQ 8xRelay	6AG1 222-1HH30-2XB0 SM 1222 DQ 16xRelay	6AG1 222-1HH30-4XB0 SM 1222 DQ 16xRelay
Based on	6ES7 222-1HF30-0XB0	6ES7 222-1HF30-0XB0	6ES7 222-1HH30-0XB0	6ES7 222-1HH30-0XB0
Climatic and mechanical conditions for storage and transport Climatic conditions for storage and transport • Free fall - Drop height, max. (in packaging)	0.3 m; five times, in dispatch package	0.3 m; five times, in dispatch package	0.3 m; five times, in dispatch package	0.3 m; five times, in dispatch package
• Temperature - Permissible temperature range	-40 °C to +70 °C	-40 °C to +70 °C	-40 °C to +70 °C	-40 °C to +70 °C
Mechanical and climatic conditions during operation Climatic conditions in operation • Temperature - Min. - max. - Permissible temperature change	-25 °C; = Tmin 70 °C; = Tmax	0 °C; = Tmin 55 °C; = Tmax 5°C to 55°C, 3°C / minute	-25 °C; = Tmin 70 °C; = Tmax	0 °C; = Tmin 55 °C; = Tmax 5°C to 55°C, 3°C / minute

Ordering data

SIPLUS SM 1222 digital output signal module

(extended temperature range and medial exposure)

8 outputs, 24 V DC;
0.5 A, 5 W, isolated

- Suitable for areas with extraordinary medial exposure (conformal coating)
- -25 ... +70 °C, from +60 ... +70°C number of simultaneously controllable inputs and outputs max. 50 %

16 outputs, 24 V DC;
0.5 A, 5 W, isolated

- Suitable for areas with extraordinary medial exposure (conformal coating)
- -25 ... +70 °C, from +60 ... +70°C number of simultaneously controllable inputs and outputs max. 50 %

Order No.

6AG1 222-1BF30-4XB0

6AG1 222-1BF30-2XB0

6AG1 222-1BH30-4XB0

6AG1 222-1BH30-2XB0

Order No.

6AG1 222-1HF30-4XB0

6AG1 222-1HF30-2XB0

6AG1 222-1HH30-4XB0

6AG1 222-1HH30-2XB0

8 relay outputs, 5 ... 30 V DC/
5 ... 250 V AC, 2 A, 30 W DC/
200 W AC

- Suitable for areas with extraordinary medial exposure (conformal coating)
- -25 ... +70 °C, from +60 ... +70°C number of simultaneously controllable inputs and outputs max. 50 %

16 relay outputs, 5 ... 30 V DC/
5 ... 250 V AC, 2 A, 30 W DC/
200 W AC

- Suitable for areas with extraordinary medial exposure (conformal coating)
- -25 ... +70 °C, from +60 ... +70°C number of simultaneously controllable inputs and outputs max. 50 %

Accessories

See SIMATIC S7-1200 SM 1222 digital output. page 3/49

SIMATIC S7-1200

SIPLUS digital modules

SIPLUS SM 1223 digital input/output modules

Overview



- Digital inputs and outputs as supplement to the integral I/O of the CPUs
- For flexible adaptation of the controller to the corresponding task
- For subsequent expansion of the system with additional inputs and outputs
- From +60 °C to +70 °C, max. 50% of the inputs can be controlled simultaneously

Note:

SIPLUS extreme products are based on Siemens Industry standard products. The contents listed here were taken from the respective standard products. SIPLUS extreme-specific information was added.

Technical specifications

The technical data correspond to those of the based-on modules apart from the values listed in the table.

	6AG1 223-1BH30-2XB0 SM 1223 DI 8x24 VDC, DQ 8x24 VDC	6AG1 223-1BH30-4XB0 SM 1223 DI 8x24 VDC, DQ 8x24 VDC	6AG1 223-1PH30-2XB0 SM 1223 DI 8x24 VDC, DQ 8xRelay	6AG1 223-1PH30-4XB0 SM 1223 DI 8x24 VDC, DQ 8xRelay
Based on	6ES7 223-1BH30-0XB0	6ES7 223-1BH30-0XB0	6ES7 223-1PH30-0XB0	6ES7 223-1PH30-0XB0
Ambient conditions				
Extended ambient conditions				
• Relative to ambient temperature-atmospheric pressure-installation altitude	Tmin ... Tmax at 1080 hPa ... 795 hPa (-1000 m ... +2000 m) // Tmin ... (Tmax - 10K) at 795 hPa ... 658 hPa (+2000 m ... +3500 m) // Tmin ... (Tmax - 20K) at 658 hPa ... 540 hPa (+3500 m ... +5000 m)	Tmin ... Tmax at 1080 hPa ... 795 hPa (-1000 m ... +2000 m) // Tmin ... (Tmax - 10K) at 795 hPa ... 658 hPa (+2000 m ... +3500 m) // Tmin ... (Tmax - 20K) at 658 hPa ... 540 hPa (+3500 m ... +5000 m)	Tmin ... Tmax at 1080 hPa ... 795 hPa (-1000 m ... +2000 m) // Tmin ... (Tmax - 10K) at 795 hPa ... 658 hPa (+2000 m ... +3500 m) // Tmin ... (Tmax - 20K) at 658 hPa ... 540 hPa (+3500 m ... +5000 m)	Tmin ... Tmax at 1080 hPa ... 795 hPa (-1000 m ... +2000 m) // Tmin ... (Tmax - 10K) at 795 hPa ... 658 hPa (+2000 m ... +3500 m) // Tmin ... (Tmax - 20K) at 658 hPa ... 540 hPa (+3500 m ... +5000 m)
• Relative humidity - with condensation	100 %; Relative humidity, incl. condensation / frost permitted (no commissioning under condensation conditions)	100 %; Relative humidity, incl. condensation / frost permitted (no commissioning under condensation conditions)	100 %; Relative humidity, incl. condensation / frost permitted (no commissioning under condensation conditions)	100 %; Relative humidity, incl. condensation / frost permitted (no commissioning under condensation conditions)
• Resistance - to biologically active substances	Yes; Class 3B2 mold, fungus and dry rot spores (with the exception of fauna). The supplied connector covers must remain on the unused interfaces during operation!	Yes; Class 3B2 mold, fungus and dry rot spores (with the exception of fauna). The supplied connector covers must remain on the unused interfaces during operation!	Yes; Class 3B2 mold, fungus and dry rot spores (with the exception of fauna). The supplied connector covers must remain on the unused interfaces during operation!	Yes; Class 3B2 mold, fungus and dry rot spores (with the exception of fauna). The supplied connector covers must remain on the unused interfaces during operation!
- to chemically active substances	Yes; Class 3C4 incl. salt spray according to EN 60068-2-52 (degree of severity 3). The supplied connector covers must remain on the unused interfaces during operation!	Yes; Class 3C4 incl. salt spray according to EN 60068-2-52 (degree of severity 3). The supplied connector covers must remain on the unused interfaces during operation!	Yes; Class 3C4 incl. salt spray according to EN 60068-2-52 (degree of severity 3). The supplied connector covers must remain on the unused interfaces during operation!	Yes; Class 3C4 incl. salt spray according to EN 60068-2-52 (degree of severity 3). The supplied connector covers must remain on the unused interfaces during operation!
- to mechanically active substances	Yes; Class 3S4 incl. sand, dust. The supplied connector covers must remain on the unused interfaces during operation!	Yes; Class 3S4 incl. sand, dust. The supplied connector covers must remain on the unused interfaces during operation!	Yes; Class 3S4 incl. sand, dust. The supplied connector covers must remain on the unused interfaces during operation!	Yes; Class 3S4 incl. sand, dust. The supplied connector covers must remain on the unused interfaces during operation!

Technical specifications (continued)

	6AG1 223-1BH30-2XB0 SM 1223 DI 8x24 VDC, DQ 8x24 VDC	6AG1 223-1BH30-4XB0 SM 1223 DI 8x24 VDC, DQ 8x24 VDC	6AG1 223-1PH30-2XB0 SM 1223 DI 8x24 VDC, DQ 8xRelay	6AG1 223-1PH30-4XB0 SM 1223 DI 8x24 VDC, DQ 8xRelay
Based on	6ES7 223-1BH30-0XB0	6ES7 223-1BH30-0XB0	6ES7 223-1PH30-0XB0	6ES7 223-1PH30-0XB0
Climatic and mechanical conditions for storage and transport Climatic conditions for storage and transport				
• Free fall - Drop height, max. (in packaging)	0.3 m; five times, in dispatch package	0.3 m; five times, in dispatch package	0.3 m; five times, in dispatch package	0.3 m; five times, in dispatch package
• Temperature - Permissible temperature range	-40 °C to +70 °C	-40 °C to +70 °C	-40 °C to +70 °C	-40 °C to +70 °C
Mechanical and climatic conditions during operation Climatic conditions in operation				
• Temperature - Min. - max. - Permissible temperature change	-25 °C; = Tmin 70 °C; = Tmax	0 °C; = Tmin 55 °C; = Tmax 5°C to 55°C, 3°C / minute	-25 °C; = Tmin 70 °C; = Tmax	0 °C; = Tmin 55 °C; = Tmax 5°C to 55°C, 3°C / minute
Based on	6AG1 223-1PL30-2XB0 SM 1223 DI 16x24 VDC, DQ 16xRelay	6AG1 223-1PL30-4XB0 SM 1223 DI 16x24 VDC, DQ 16xRelay	6AG1 223-1BL30-2XB0 SM 1223 DI 16x24 VDC, DQ 16x24 VDC	6AG1 223-1BL30-4XB0 SM 1223 DI 16x24 VDC, DQ 16x24 VDC
Based on	6ES7 223-1PL30-0XB0	6ES7 223-1PL30-0XB0	6ES7 223-1BL30-0XB0	6ES7 223-1BL30-0XB0
Ambient conditions Extended ambient conditions				
• Relative to ambient temperature-atmospheric pressure-installation altitude	Tmin ... Tmax at 1080 hPa ... 795 hPa (-1000 m ... +2000 m) // Tmin ... (Tmax - 10K) at 795 hPa ... 658 hPa (+2000 m ... +3500 m) // Tmin ... (Tmax - 20K) at 658 hPa ... 540 hPa (+3500 m ... +5000 m)	Tmin ... Tmax at 1080 hPa ... 795 hPa (-1000 m ... +2000 m) // Tmin ... (Tmax - 10K) at 795 hPa ... 658 hPa (+2000 m ... +3500 m) // Tmin ... (Tmax - 20K) at 658 hPa ... 540 hPa (+3500 m ... +5000 m)	Tmin ... Tmax at 1080 hPa ... 795 hPa (-1000 m ... +2000 m) // Tmin ... (Tmax - 10K) at 795 hPa ... 658 hPa (+2000 m ... +3500 m) // Tmin ... (Tmax - 20K) at 658 hPa ... 540 hPa (+3500 m ... +5000 m)	Tmin ... Tmax at 1080 hPa ... 795 hPa (-1000 m ... +2000 m) // Tmin ... (Tmax - 10K) at 795 hPa ... 658 hPa (+2000 m ... +3500 m) // Tmin ... (Tmax - 20K) at 658 hPa ... 540 hPa (+3500 m ... +5000 m)
• Relative humidity - with condensation	100 %; Relative humidity, incl. condensation / frost permitted (no commissioning under condensation conditions)	100 %; Relative humidity, incl. condensation / frost permitted (no commissioning under condensation conditions)	100 %; Relative humidity, incl. condensation / frost permitted (no commissioning under condensation conditions)	100 %; Relative humidity, incl. condensation / frost permitted (no commissioning under condensation conditions)
• Resistance - to biologically active substances	Yes; Class 3B2 mold, fungus and dry rot spores (with the exception of fauna). The supplied connector covers must remain on the unused interfaces during operation!	Yes; Class 3B2 mold, fungus and dry rot spores (with the exception of fauna). The supplied connector covers must remain on the unused interfaces during operation!	Yes; Class 3B2 mold, fungus and dry rot spores (with the exception of fauna). The supplied connector covers must remain on the unused interfaces during operation!	Yes; Class 3B2 mold, fungus and dry rot spores (with the exception of fauna). The supplied connector covers must remain on the unused interfaces during operation!
- to chemically active substances	Yes; Class 3C4 incl. salt spray according to EN 60068-2-52 (degree of severity 3). The supplied connector covers must remain on the unused interfaces during operation!	Yes; Class 3C4 incl. salt spray according to EN 60068-2-52 (degree of severity 3). The supplied connector covers must remain on the unused interfaces during operation!	Yes; Class 3C4 incl. salt spray according to EN 60068-2-52 (degree of severity 3). The supplied connector covers must remain on the unused interfaces during operation!	Yes; Class 3C4 incl. salt spray according to EN 60068-2-52 (degree of severity 3). The supplied connector covers must remain on the unused interfaces during operation!
- to mechanically active substances	Yes; Class 3S4 incl. sand, dust. The supplied connector covers must remain on the unused interfaces during operation!	Yes; Class 3S4 incl. sand, dust. The supplied connector covers must remain on the unused interfaces during operation!	Yes; Class 3S4 incl. sand, dust. The supplied connector covers must remain on the unused interfaces during operation!	Yes; Class 3S4 incl. sand, dust. The supplied connector covers must remain on the unused interfaces during operation!

SIMATIC S7-1200

SIPLUS digital modules

SIPLUS SM 1223 digital input/output modules

Technical specifications (continued)

	6AG1 223-1PL30-2XB0 SM 1223 DI 16x24 VDC, DQ 16xRelay	6AG1 223-1PL30-4XB0 SM 1223 DI 16x24 VDC, DQ 16xRelay	6AG1 223-1BL30-2XB0 SM 1223 DI 16x24 VDC, DQ 16x24 VDC	6AG1 223-1BL30-4XB0 SM 1223 DI 16x24 VDC, DQ 16x24 VDC
Based on	6ES7 223-1PL30-0XB0	6ES7 223-1PL30-0XB0	6ES7 223-1BL30-0XB0	6ES7 223-1BL30-0XB0
Climatic and mechanical conditions for storage and transport				
Climatic conditions for storage and transport				
• Free fall				
- Drop height, max. (in packaging)	0.3 m; five times, in dispatch package	0.3 m; five times, in dispatch package	0.3 m; five times, in dispatch package	0.3 m; five times, in dispatch package
• Temperature				
- Permissible temperature range	-40 °C to +70 °C	-40 °C to +70 °C	-40 °C to +70 °C	-40 °C to +70 °C
Mechanical and climatic conditions during operation				
Climatic conditions in operation				
• Temperature				
- Min.	-25 °C; = Tmin	0 °C; = Tmin	-25 °C; = Tmin	0 °C; = Tmin
- max.	70 °C; = Tmax	55 °C; = Tmax	70 °C; = Tmax	55 °C; = Tmax
- Permissible temperature change		5°C to 55°C, 3°C / minute		5°C to 55°C, 3°C / minute

Ordering data

SIPLUS SM 1223 digital input/output signal module

(extended temperature range and medial exposure)

8 inputs, 24 V DC,
IEC type 1 current sinking;
8 transistor outputs, 24 V DC,
0.5 A, 5 W

- Suitable for areas with extraordinary medial exposure (conformal coating)
- -25 ... +70 °C,
from +60 ... +70 °C number of simultaneously controllable inputs and outputs max. 50 %

16 inputs, 24 V DC,
IEC type 1 current sinking;
16 transistor outputs, 24 V DC,
0.5 A, 5 W

- Suitable for areas with extraordinary medial exposure (conformal coating)
- -25 ... +70 °C,
from +60 ... +70 °C number of simultaneously controllable inputs and outputs max. 50 %

Order No.

6AG1 223-1BH30-4XB0

6AG1 223-1BH30-2XB0

6AG1 223-1BL30-4XB0

6AG1 223-1BL30-2XB0

Order No.

8 inputs, 24 V DC,
IEC type 1 current sinking;
8 relay outputs, 5 ... 30 V DC /
5 ... 250 V AC, 2 A, 30 W DC /
200 W AC

- Suitable for areas with extraordinary medial exposure (conformal coating)
- -25 ... +70 °C,
from +60 ... +70 °C number of simultaneously controllable inputs and outputs max. 50 %

6AG1 223-1PH30-4XB0

6AG1 223-1PH30-2XB0

16 inputs, 24 V DC,
IEC type 1 current sinking;
16 relay outputs, 5 ... 30 V DC /
5 ... 250 V AC, 2 A, 30 W DC /
200 W AC

- Suitable for areas with extraordinary medial exposure (conformal coating)
- -25 ... +70 °C,
from +60 ... +70 °C number of simultaneously controllable inputs and outputs max. 50 %

6AG1 223-1PL30-4XB0

6AG1 223-1PL30-2XB0

Accessories

See SIMATIC S7-1200
SM 1223 digital input/output,
page 3/57

Overview



- Digital inputs and outputs as supplement to the integral I/O of the SIPLUS S7-1200-CPU
- Can be plugged directly into the CPU (cannot be used for +70 °C version)

Note:

SIPLUS extreme products are based on Siemens Industry standard products. The contents listed here were taken from the respective standard products. SIPLUS extreme-specific information was added.

3

Technical specifications

The technical data correspond to those of the based-on modules apart from the values listed in the table.

	6AG1 223-0BD30-4XB0 SB 1223 DI2x24 VDC, DQ 2x24 VDC 6ES7 223-0BD30-0XB0	6AG1 223-0BD30-5XB0 SB 1223 DI2x24 VDC, DQ 2x24 VDC 6ES7 223-0BD30-0XB0
Based on		
Ambient conditions Extended ambient conditions		
<ul style="list-style-type: none"> • Relative to ambient temperature-atmospheric pressure-installation altitude 	Tmin ... Tmax at 1080 hPa ... 795 hPa (-1000 m ... +2000 m) // Tmin ... (Tmax - 10K) at 795 hPa ... 658 hPa (+2000 m ... +3500 m) // Tmin ... (Tmax - 20K) at 658 hPa ... 540 hPa (+3500 m ... +5000 m)	Tmin ... Tmax at 1080 hPa ... 795 hPa (-1000 m ... +2000 m) // Tmin ... (Tmax - 10K) at 795 hPa ... 658 hPa (+2000 m ... +3500 m) // Tmin ... (Tmax - 20K) at 658 hPa ... 540 hPa (+3500 m ... +5000 m)
<ul style="list-style-type: none"> • Relative humidity <ul style="list-style-type: none"> - with condensation 	100 %; Relative humidity, incl. condensation / frost permitted (no commissioning under condensation conditions)	100 %; Relative humidity, incl. condensation / frost permitted (no commissioning under condensation conditions)
<ul style="list-style-type: none"> • Resistance <ul style="list-style-type: none"> - to biologically active substances - to chemically active substances - to mechanically active substances 	Yes; Class 3B2 mold, fungus and dry rot spores (with the exception of fauna). The supplied connector covers must remain on the unused interfaces during operation! Yes; Class 3C4 incl. salt spray according to EN 60068-2-52 (degree of severity 3). The supplied connector covers must remain on the unused interfaces during operation! Yes; Class 3S4 incl. sand, dust. The supplied connector covers must remain on the unused interfaces during operation!	Yes; Class 3B2 mold, fungus and dry rot spores (with the exception of fauna). The supplied connector covers must remain on the unused interfaces during operation! Yes; Class 3C4 incl. salt spray according to EN 60068-2-52 (degree of severity 3). The supplied connector covers must remain on the unused interfaces during operation! Yes; Class 3S4 incl. sand, dust. The supplied connector covers must remain on the unused interfaces during operation!
Climatic and mechanical conditions for storage and transport Climatic conditions for storage and transport		
<ul style="list-style-type: none"> • Free fall <ul style="list-style-type: none"> - Drop height, max. (in packaging) • Temperature <ul style="list-style-type: none"> - Permissible temperature range 	0.3 m; five times, in dispatch package -40 °C to +70 °C	0.3 m; five times, in dispatch package -40 °C to +70 °C
Mechanical and climatic conditions during operation Climatic conditions in operation		
<ul style="list-style-type: none"> • Temperature <ul style="list-style-type: none"> - Min. - max. 	0 °C; = Tmin 55 °C; = Tmax	-25 °C; = Tmin 55 °C; = Tmax

SIMATIC S7-1200

SIPLUS digital modules

SIPLUS SB 1223 digital input/output modules

Ordering data

Order No.

SIPLUS SM 1223 digital input/output signal board

(extended temperature range and
medial exposure)

2 inputs, 24 V DC,
IEC type 1 current sinking;
2 transistor outputs, 24 V DC, 0.5 A,
5 W;
usable as HSC up to 30 kHz

- Suitable for areas with
extraordinary medial exposure
(conformal coating)
- Ambient temperature -25 ... +55 °C

6AG1 223-0BD30-4XB0

6AG1 223-0BD30-5XB0

3

Overview



- Analog inputs for SIMATIC S7-1200
- With extremely short conversion times
- For connecting analog sensors without additional amplifiers
- For solving even more complex automation tasks

Technical specifications

	6ES7 231-4HD32-0XB0	6ES7 231-4HF32-0XB0	6ES7 231-5ND32-0XB0
Supply voltage 24 V DC	Yes		Yes
Input current Current consumption, typ.	45 mA		65 mA
from backplane bus 5 V DC, typ.	80 mA		80 mA
Power losses Power loss, typ.	1.5 W		1.8 W
Analog inputs Number of analog inputs	4; Current or voltage differential inputs	8; Current or voltage differential inputs	4; Current or voltage differential inputs
permissible input frequency for current input (destruction limit), max.	± 35 V	± 35 V	± 35 V
permissible input voltage for voltage input (destruction limit), max.	35 V	35 V	35 V
permissible input current for voltage input (destruction limit), max.	40 mA	40 mA	40 mA
permissible input current for current input (destruction limit), max.	40 mA	40 mA	40 mA
Cycle time (all channels) max.	625 µs	625 µs	625 µs
Input ranges • Voltage • Current	Yes; ±10 V, ±5 V, ±2.5 V Yes; 4 to 20 mA, 0 to 20 mA	Yes; ±10 V, ±5 V, ±2.5 V Yes; 4 to 20 mA, 0 to 20 mA	Yes; ±10 V, ±5 V, ±2.5 V o. ±1.25 V Yes; 4 to 20 mA, 0 to 20 mA
Input ranges (rated values), voltages • -1.25 to +1.25 V • -10 V to +10 V • Input resistance (-10 V to +10 V) • -2.5 V to +2.5 V • Input resistance (-2.5 V to +2.5 V) • -5 V to +5 V • Input resistance (-5 V to +5 V)	Yes ≥9 MOhm Yes ≥9 MOhm Yes ≥9 MOhm	Yes ≥9 MOhm Yes ≥9 MOhm Yes ≥9 MOhm	Yes Yes ≥9 MOhm Yes ≥9 MOhm Yes ≥9 MOhm
Input ranges (rated values), currents • 0 to 20 mA • Input resistance (0 to 20 mA) • 4 to 20 mA	Yes 280 Ω Yes	Yes	Yes Yes

SIMATIC S7-1200

Analog modules

SM 1231 analog input modules

Technical specifications (continued)

	6ES7 231-4HD32-0XB0	6ES7 231-4HF32-0XB0	6ES7 231-5ND32-0XB0
Analog value creation			
Integrations and conversion time/ resolution per channel			
• Resolution with overrange (bit including sign), max.	12 bit; + sign	12 bit; + sign	15 bit; + sign
• Integration time, parameterizable	Yes	Yes	Yes
• Interference voltage suppression for interference frequency f_1 in Hz	40 dB, DC to 60 V for interference frequency 50 / 60 Hz	40 dB, DC to 60 V for interference frequency 50 / 60 Hz	40 dB, DC to 60 V for interference frequency 50 / 60 Hz
Smoothing of measured values			
• Parameterizable	Yes	Yes	Yes
• Step: None	Yes	Yes	Yes
• Step: low	Yes	Yes	Yes
• Step: Medium	Yes	Yes	Yes
• Step: High	Yes	Yes	Yes
Errors/accuracies			
Temperature error (relative to input area)	25 °C ± 0.1 % to 55 °C ± 0.2 % total measurement range	25 °C ± 0.1 % to 55 °C ± 0.2 % total measurement range	25 °C ± 0.1 % / ± 0.3 % total measurement range
Basic error limit (operational limit at 25 °C)			
• Voltage, relative to input area	+/- 0,1 %	+/- 0,1 %	+/- 0,1 %
• Current, relative to input area	+/- 0,1 %	+/- 0,1 %	+/- 0,1 %
Interference voltage suppression for $f = n \times (f_1 \pm 1\%)$, $f_1 =$ interference frequency			
• common mode voltage, max.	12 V	12 V	12 V
Interrupts/diagnostics/ status information			
Alarms			
• Alarms	Yes	Yes	Yes
• Diagnostic alarm	Yes	Yes	Yes
Diagnostic messages			
• Diagnostic functions	Yes	Yes	Yes
• Monitoring the supply voltage	Yes	Yes	Yes
• Wire break	Yes	Yes	Yes
Diagnostics indication LED			
• for status of the inputs	Yes	Yes	Yes
• for maintenance	Yes	Yes	Yes
Galvanic isolation			
Galvanic isolation analog outputs			
• between the channels and the power supply of the electronics	No	No	No
Degree and class of protection			
IP20	Yes	Yes	Yes
Standards, approvals, certificates			
CE mark	Yes	Yes	Yes
CSA approval	Yes	Yes	Yes
C-TICK	Yes	Yes	Yes
FM approval	Yes	Yes	Yes
Marine approval	Yes	Yes	Yes

Technical specifications (continued)

	6ES7 231-4HD32-0XB0	6ES7 231-4HF32-0XB0	6ES7 231-5ND32-0XB0
Climatic and mechanical conditions for storage and transport			
Climatic conditions for storage and transport			
• Free fall			
- Drop height, max. (in packaging)	0.3 m; five times, in dispatch package	0.3 m; five times, in dispatch package	0.3 m; five times, in dispatch package
• Temperature			
- Permissible temperature range	-40 °C to +70 °C	-40 °C to +70 °C	-40 °C to +70 °C
• Air pressure acc. to IEC 60068-2-13			
- Permissible air pressure	1080 to 660 hPa	1080 to 660 hPa	1080 to 660 hPa
Mechanical and climatic conditions during operation			
Climatic conditions in operation			
• Temperature			
- Min.	-20 °C	-20 °C	-20 °C
- max.	60 °C	60 °C	60 °C
• Air pressure acc. to IEC 60068-2-13			
- Permissible air pressure	1080 to 795 hPa	1080 to 795 hPa	1080 to 795 hPa
• Pollutant concentrations			
- SO ₂ at RH < 60% without condensation	SO ₂ : < 0.5 ppm; H ₂ S: < 0.1 ppm; RH < 60% condensation-free	SO ₂ : < 0.5 ppm; H ₂ S: < 0.1 ppm; RH < 60% condensation-free	SO ₂ : < 0.5 ppm; H ₂ S: < 0.1 ppm; RH < 60% condensation-free
Connection method			
required front connector	Yes	Yes	Yes
Mechanics/material			
Type of housing (front)			
• Plastic	Yes	Yes	Yes
Dimensions			
Width	45 mm	45 mm	45 mm
Height	100 mm	100 mm	100 mm
Depth	75 mm	75 mm	75 mm
Weight			
Weight, approx.	180 g	180 g	180 g

SIMATIC S7-1200

Analog modules

SM 1231 analog input modules

Ordering data

SM 1231 analog input signal module

4 analog inputs, $\pm 10V$, $\pm 5V$, $\pm 2.5V$, or 0 ... 20 mA, 16 bits

6ES7 231-5ND32-0XB0

4 analog inputs, $\pm 10V$, $\pm 5V$, $\pm 2.5V$, or 0 ... 20 mA, 12 bits + sign

6ES7 231-4HD32-0XB0

8 analog inputs, $\pm 10V$, $\pm 5V$, $\pm 2.5V$, or 0 ... 20 mA, 12 bits + sign

6ES7 231-4HF32-0XB0

Extension cable for two-tier configuration

for connecting digital/analog signal modules; length 2 m

6ES7 290-6AA30-0XA0

Terminal block (spare part)

for 8/16-channel analog signal modules

with 7 screws, gold-plated; 4 pcs.

6ES7 292-1BG30-0XA0

Front flap set (spare part)

for 8/16-channel signal modules

6ES7 291-1BA30-0XA0

S7-1200 automation system, System Manual

for SIMATIC S7-1200 and STEP 7 Basic

German

6ES7 298-8FA30-8AH0

English

6ES7 298-8FA30-8BH0

French

6ES7 298-8FA30-8CH0

Spanish

6ES7 298-8FA30-8DH0

Italian

6ES7 298-8FA30-8EH0

Chinese

6ES7 298-8FA30-8KH0

S7-1200 automation system, Easy Book

Brief instructions

German

6ES7 298-8FA30-8AQ0

English

6ES7 298-8FA30-8BQ0

French

6ES7 298-8FA30-8CQ0

Spanish

6ES7 298-8FA30-8DQ0

Italian

6ES7 298-8FA30-8EQ0

Chinese

6ES7 298-8FA30-8KQ0

Overview

- Analog input module for the SIMATIC S7-1200
- With extremely short conversion times
- For the connection of analog sensors without additional amplifiers
- For the solution of more complex automation tasks as well
- Can be plugged directly into the CPU

Technical specifications

6ES7 231-4HA30-0XB0 SB1231 AI 1x12 BIT		6ES7 231-4HA30-0XB0 SB1231 AI 1x12 BIT	
Supply voltage 24 V DC	Yes	Analog value creation Measurement principle	integrating
Input current from backplane bus 5 V DC, typ.	55 mA	Integrations and conversion time/ resolution per channel	
Power losses Power loss, typ.	0.4 W	• Resolution with overrange (bit including sign), max.	11 bit; + sign
Analog inputs Number of analog inputs	1; Current or voltage differential inputs	• Integration time, parameterizable	Yes
permissible input frequency for current input (destruction limit), max.	± 35 V	• Interference voltage suppression for interference frequency f1 in Hz	40 dB, DC to 60 Hz
permissible input voltage for voltage input (destruction limit), max.	35 V	Smoothing of measured values	
permissible input current for voltage input (destruction limit), max.	40 mA	• Parameterizable	Yes
permissible input current for current input (destruction limit), max.	40 mA	• Step: None	Yes
Cycle time (all channels) max.	156.25 µs; 400 Hz suppression	• Step: low	Yes
Input ranges		• Step: Medium	Yes
• Voltage	Yes; ±10 V, ±5 V, ±2.5 V	• Step: High	Yes
• Current	Yes; 0 to 20 mA	Errors/accuracies	
• Thermocouple	No	Temperature error (relative to input area)	25 °C ±0.3% to 55 °C ±0.6% total measurement range
• Resistance thermometer	No	Interrupts/diagnostics/ status information	
• Resistance	No	Alarms	
Input ranges (rated values), voltages		• Alarms	Yes
• -10 V to +10 V	Yes	• Diagnostic alarm	Yes
• Input resistance (-10 V to +10 V)	≥9 MOhm	Diagnostic messages	
• -2.5 V to +2.5 V	Yes	• Diagnostic functions	Yes
• Input resistance (-2.5 V to +2.5 V)	≥9 MOhm	• Wire break	No
• -5 V to +5 V	Yes	Diagnostic indication LED	
• Input resistance (-5 V to +5 V)	≥9 MOhm	• for status of the inputs	Yes
Input ranges (rated values), currents		• for maintenance	Yes
• 0 to 20 mA	Yes	Degree and class of protection	
• Input resistance (0 to 20 mA)	≥ 250 ohms	IP20	Yes
		Standards, approvals, certificates	
		CE mark	Yes
		C-TICK	Yes
		FM approval	Yes

SIMATIC S7-1200

Analog modules

SB 1231 analog input modules

Technical specifications (continued)

6ES7 231-4HA30-0XB0 SB1231 AI 1x12 BIT		6ES7 231-4HA30-0XB0 SB1231 AI 1x12 BIT	
Climatic and mechanical conditions for storage and transport Climatic conditions for storage and transport		Connection method	
<ul style="list-style-type: none"> Free fall - Drop height, max. (in packaging) 		required front connector	Yes
<ul style="list-style-type: none"> Temperature - Permissible temperature range 		Mechanics/material	
<ul style="list-style-type: none"> Air pressure acc. to IEC 60068-2-13 - Permissible air pressure 		Type of housing (front)	Yes
		Dimensions	
		Width	38 mm
		Height	62 mm
		Depth	21 mm
		Weight	
		Weight, approx.	35 g
Mechanical and climatic conditions during operation Climatic conditions in operation			
<ul style="list-style-type: none"> Temperature - Permissible temperature range 			
<ul style="list-style-type: none"> Air pressure acc. to IEC 60068-2-13 - Permissible air pressure 			
<ul style="list-style-type: none"> Pollutant concentrations - SO₂ at RH < 60% without condensation 			

Ordering data

Order No.	Order No.
SB 1231 analog input signal board 1 analog input, ±10 V with 12 bits or 0 ... 20 mA with 11 bits	6ES7 231-4HA30-0XB0
Terminal block (spare part) for signal board with 6 screws, gold-plated; 4 pcs.	6ES7 292-1BF30-0XA0
S7-1200 automation system, System Manual for SIMATIC S7-1200 and STEP 7 Basic	
German	6ES7 298-8FA30-8AH0
English	6ES7 298-8FA30-8BH0
French	6ES7 298-8FA30-8CH0
Spanish	6ES7 298-8FA30-8DH0
Italian	6ES7 298-8FA30-8EH0
Chinese	6ES7 298-8FA30-8KH0
S7-1200 automation system, Easy Book	
Brief instructions	
German	6ES7 298-8FA30-8AQ0
English	6ES7 298-8FA30-8BQ0
French	6ES7 298-8FA30-8CQ0
Spanish	6ES7 298-8FA30-8DQ0
Italian	6ES7 298-8FA30-8EQ0
Chinese	6ES7 298-8FA30-8KQ0

Overview



- Analog outputs for SIMATIC S7-1200
- With extremely short conversion times
- For connecting analog actuators without additional amplifiers
- For solving even more complex automation tasks

Technical specifications

	6ES7 232-4HB32-0XB0 SM 1232 AQ 2x14 bit	6ES7 232-4HD32-0XB0 SM 1232 AQ 4 x 14bit
Supply voltage 24 V DC	Yes	Yes
Input current Current consumption, typ.	45 mA	45 mA
from backplane bus 5 V DC, typ.	80 mA	80 mA
Power losses Power loss, typ.	1.5 W	1.5 W
Analog inputs Number of analog inputs	0	
Thermocouple (TC) • Temperature compensation - Parameterizable	No	No
Analog outputs Number of analog outputs	2; Current or voltage	4; Current or voltage
Output ranges, voltage • -10 to +10 V	Yes	Yes
Output ranges, current • 0 to 20 mA	Yes	Yes
Load impedance (in rated range of output) • with voltage outputs, min. • with current outputs, max.	1 000 Ω 600 Ω	1 000 Ω 600 Ω
Analog value creation Measurement principle	Differential	Differential
Integrations and conversion time/ resolution per channel • Resolution (incl. overrange) • Integration time, parameterizable • Interference voltage suppression for interference frequency f1 in Hz	Voltage: 14 bits; Current : 13 bits Yes 40 dB, DC to 60 V for interference frequency 50 / 60 Hz	Voltage: 14 bits; Current : 13 bits Yes 40 dB, DC to 60 V for interference frequency 50 / 60 Hz

SIMATIC S7-1200

Analog modules

SM 1232 analog output modules

Technical specifications (continued)

	6ES7 232-4HB32-0XB0 SM 1232 AQ 2x14 bit	6ES7 232-4HD32-0XB0 SM 1232 AQ 4 x 14bit
Errors/accuracies		
Temperature error (relative to output area)	25 °C ±0.3% to 55 °C ±0.6% total measurement range	25 °C ±0.3% to 55 °C ±0.6% total measurement range
Basic error limit (operational limit at 25 °C)		
• Voltage, relative to output area	+/- 0,3 %	+/- 0,3 %
• Current, relative to output area	+/- 0,3 %	+/- 0,3 %
Interference voltage suppression for $f = n \times (f_1 \pm 1\%)$, $f_1 =$ interference frequency		
• common mode voltage, max.	12 V	12 V
Interrupts/diagnostics/ status information		
Alarms		
• Alarms	Yes	Yes
• Diagnostic alarm	Yes	Yes
Diagnostic messages		
• Diagnostic functions	Yes	Yes
• Monitoring the supply voltage	Yes	Yes
• Wire break	Yes	Yes
• Short circuit	Yes	Yes
Diagnostics indication LED		
• For status of the outputs	Yes	Yes
• for maintenance	Yes	Yes
Degree and class of protection		
IP20	Yes	Yes
Standards, approvals, certificates		
CE mark	Yes	Yes
C-TICK	Yes	Yes
FM approval	Yes	Yes
Climatic and mechanical conditions for storage and transport		
Climatic conditions for storage and transport		
• Free fall		
- Drop height, max. (in packaging)	0.3 m; five times, in dispatch package	0.3 m; five times, in dispatch package
• Temperature		
- Permissible temperature range	-40 °C to +70 °C	-40 °C to +70 °C
• Air pressure acc. to IEC 60068-2-13		
- Permissible air pressure	1080 to 660 hPa	1080 to 660 hPa
Mechanical and climatic conditions during operation		
Climatic conditions in operation		
• Temperature		
- Min.	-20 °C	-20 °C
- max.	60 °C	60 °C
• Air pressure acc. to IEC 60068-2-13		
- Permissible air pressure	1080 to 795 hPa	1080 to 795 hPa
• Pollutant concentrations		
- SO ₂ at RH < 60% without condensation	SO ₂ : < 0.5 ppm; H ₂ S: < 0.1 ppm; RH < 60% condensation-free	SO ₂ : < 0.5 ppm; H ₂ S: < 0.1 ppm; RH < 60% condensation-free

Technical specifications (continued)

	6ES7 232-4HB32-0XB0 SM 1232 AQ 2x14 bit	6ES7 232-4HD32-0XB0 SM 1232 AQ 4 x 14bit
Connection method required front connector	Yes	Yes
Mechanics/material Type of housing (front) • Plastic	Yes	Yes
Dimensions		
Width	45 mm	45 mm
Height	100 mm	100 mm
Depth	75 mm	75 mm
Weight Weight, approx.	180 g	180 g

Ordering data

	Order No.		Order No.
SM 1232 analog output signal module 2 analog outputs, ± 10 V with 14 bits or 0 ... 20 mA with 13 bits 4 analog outputs, ± 10 V with 14 bits or 0 ... 20 mA with 13 bits	6ES7 232-4HB32-0XB0 6ES7 232-4HD32-0XB0	S7-1200 automation system, System Manual for SIMATIC S7-1200 and STEP 7 Basic German English French Spanish Italian Chinese	6ES7 298-8FA30-8AH0 6ES7 298-8FA30-8BH0 6ES7 298-8FA30-8CH0 6ES7 298-8FA30-8DH0 6ES7 298-8FA30-8EH0 6ES7 298-8FA30-8KH0
Terminal block (spare part) for 8/16-channel analog signal modules with 7 screws, gold-plated; 4 pcs.	6ES7 292-1BG30-0XA0	S7-1200 automation system, Easy Book Brief instructions German English French Spanish Italian Chinese	6ES7 298-8FA30-8AQ0 6ES7 298-8FA30-8BQ0 6ES7 298-8FA30-8CQ0 6ES7 298-8FA30-8DQ0 6ES7 298-8FA30-8EQ0 6ES7 298-8FA30-8KQ0
Extension cable for two-tier configuration for connecting digital/analog signal modules; length 2 m	6ES7 290-6AA30-0XA0		
Front flap set (spare part) for 8/16-channel signal modules	6ES7 291-1BA30-0XA0		

SIMATIC S7-1200

Analog modules

SB 1232 analog output modules

Overview



- Analog output for the SIMATIC S7-1200
- Can be plugged direct into the CPU

Technical specifications

	6ES7 232-4HA30-0XB0 SB 1232 1x AO
Input current from backplane bus 5 V DC, typ.	15 mA
Output voltage Power supply to the transmitters • Supply current, max.	25 mA
Power losses Power loss, typ.	1.5 W
Analog outputs Number of analog outputs	1
Cycle time (all channels) max.	Voltage: 300 μ S (R), 750 μ S (1 μ F) Current: 600 ms (1 mH); 2 ms (10 mH)
Output ranges, voltage • -10 to +10 V	Yes
Output ranges, current • 0 to 20 mA	Yes
Load impedance (in rated range of output) • with voltage outputs, min. • with current outputs, max.	1 000 Ω 600 Ω
Cable length • Cable length, shielded, max.	10 m; Shielded, twisted wire pair
Analog value creation Measurement principle	Differential
Integrations and conversion time/ resolution per channel • Resolution (incl. overrange)	V/12 bits, I/11 bits
Smoothing of measured values • Parameterizable	Yes
Errors/accuracies Temperature error (relative to output area)	25°C \pm 0.5% bis 55°C \pm 1%
Interrupts/diagnostics/ status information Alarms • Alarms	Yes
Diagnostic messages • Diagnostic functions	Yes
Diagnostics indication LED • For status of the outputs	Yes

	6ES7 232-4HA30-0XB0 SB 1232 1x AO
Degree and class of protection IP20	Yes
Standards, approvals, certificates CE mark	Yes
C-TICK	Yes
FM approval	Yes
Climatic and mechanical conditions for storage and transport Climatic conditions for storage and transport • Free fall - Drop height, max. (in packaging)	0.3 m; five times, in dispatch package
• Temperature - Permissible temperature range	-40 °C to +70 °C
• Air pressure acc. to IEC 60068-2-13 - Permissible air pressure	1080 to 660 hPa
Mechanical and climatic conditions during operation Climatic conditions in operation • Temperature - Permissible temperature range	0 °C to 55 °C horizontal installation 0 °C to 45 °C vertical installation
• Pollutant concentrations - SO ₂ at RH < 60% without condensation	SO ₂ : < 0.5 ppm; H ₂ S: < 0.1 ppm; RH < 60% condensation-free
Mechanics/material Type of housing (front) • Plastic	Yes
Dimensions Width	38 mm
Height	62 mm
Depth	21 mm
Weight Weight, approx.	40 g

Ordering data	Order No.		Order No.
SB 1232 analog output signal board 1 analog output, ± 10 V with 12 bits or 0 ... 20 mA with 11 bits	6ES7 232-4HA30-0XB0		
Terminal block (spare part) for signal board with 6 screws, gold-plated; 4 pcs.	6ES7 292-1BF30-0XA0		
S7-1200 automation system, System Manual for SIMATIC S7-1200 and STEP 7 Basic		S7-1200 automation system, Easy Book Brief instructions	
German	6ES7 298-8FA30-8AH0	German	6ES7 298-8FA30-8AQ0
English	6ES7 298-8FA30-8BH0	English	6ES7 298-8FA30-8BQ0
French	6ES7 298-8FA30-8CH0	French	6ES7 298-8FA30-8CQ0
Spanish	6ES7 298-8FA30-8DH0	Spanish	6ES7 298-8FA30-8DQ0
Italian	6ES7 298-8FA30-8EH0	Italian	6ES7 298-8FA30-8EQ0
Chinese	6ES7 298-8FA30-8KH0	Chinese	6ES7 298-8FA30-8KQ0

SIMATIC S7-1200

Analog modules

SM 1234 analog input/output modules

Overview



- Analog inputs and outputs for the SIMATIC S7-1200
- With extremely short conversion times
- For connecting analog actuators and sensors without additional amplifiers
- For solving even more complex automation tasks

3

Technical specifications

6ES7 234-4HE32-0XB0 SM 1234 A 14x13 bit AQ 2x14 bit	
Supply voltage 24 V DC	Yes
Input current Current consumption, typ.	60 mA
from backplane bus 5 V DC, typ.	80 mA
Power losses Power loss, typ.	2 W
Analog inputs	
Number of analog inputs	4; Current or voltage differential inputs
permissible input frequency for current input (destruction limit), max.	± 35 V
permissible input voltage for voltage input (destruction limit), max.	35 V
permissible input current for voltage input (destruction limit), max.	40 mA
permissible input current for current input (destruction limit), max.	40 mA
Cycle time (all channels) max.	625 µs
Input ranges	
• Voltage	Yes; ±10 V, ±5 V, ±2.5 V
• Current	Yes; 0 to 20 mA
• Thermocouple	No
• Resistance thermometer	No
• Resistance	No
Input ranges (rated values), voltages	
• -10 V to +10 V	Yes
• Input resistance (-10 V to +10 V)	≥9 MOhm
• -2.5 V to +2.5 V	Yes
• Input resistance (-2.5 V to +2.5 V)	≥9 MOhm
• -5 V to +5 V	Yes
• Input resistance (-5 V to +5 V)	≥9 MOhm

6ES7 234-4HE32-0XB0 SM 1234 A 14x13 bit AQ 2x14 bit	
Input ranges (rated values), currents	
• 0 to 20 mA	Yes
• Input resistance (0 to 20 mA)	280 Ω
Thermocouple (TC)	
• Temperature compensation - Parameterizable	No
Analog outputs	
Number of analog outputs	2; Current or voltage
Output ranges, voltage • -10 to +10 V	Yes
Output ranges, current • 0 to 20 mA	Yes
Load impedance (in rated range of output)	
• with voltage outputs, min.	1 000 Ω
• with current outputs, max.	600 Ω
Analog value creation	
Measurement principle	Differential
Integrations and conversion time/ resolution per channel	
• Resolution (incl. overrange)	Voltage: 14 bits; Current : 13 bits
• Integration time, parameterizable	Yes
• Interference voltage suppression for interference frequency f1 in Hz	40 dB, DC to 60 V for interference frequency 50 / 60 Hz
Smoothing of measured values	
• Parameterizable	Yes
• Step: None	Yes
• Step: low	Yes
• Step: Medium	Yes
• Step: High	Yes

Technical specifications (continued)

6ES7 234-4HE32-0XB0 SM 1234 A I4x13 bit AQ 2x14 bit	
Errors/accuracies	
Temperature error (relative to input area)	25 °C ±0.1 % to 55 °C ±0.2 % total measurement range
Temperature error (relative to output area)	25 °C ±0.3% to 55 °C ±0.6% total measurement range
Basic error limit (operational limit at 25 °C)	
• Voltage, relative to input area	+/- 0,1 %
• Current, relative to input area	+/- 0,1 %
• Voltage, relative to output area	+/- 0,3 %
• Current, relative to output area	+/- 0,3 %
Interference voltage suppression for $f = n \times (f_1 \pm 1\%)$, $f_1 =$ interference frequency	
• common mode voltage, max.	12 V
Interrupts/diagnostics/status information	
Alarms	
• Alarms	Yes
• Diagnostic alarm	Yes
Diagnostic messages	
• Diagnostic functions	Yes
• Monitoring the supply voltage	Yes
• Wire break	Yes
• Short circuit	Yes
Diagnostics indication LED	
• for status of the inputs	Yes
• For status of the outputs	Yes
• for maintenance	Yes
Galvanic isolation	
Galvanic isolation analog outputs	
• between the channels and the power supply of the electronics	No
Degree and class of protection	
IP20	Yes
Standards, approvals, certificates	
CE mark	Yes
C-TICK	Yes
FM approval	Yes

6ES7 234-4HE32-0XB0 SM 1234 A I4x13 bit AQ 2x14 bit	
Climatic and mechanical conditions for storage and transport	
Climatic conditions for storage and transport	
• Free fall	
- Drop height, max. (in packaging)	0.3 m; five times, in dispatch package
• Temperature	
- Permissible temperature range	-40 °C to +70 °C
• Air pressure acc. to IEC 60068-2-13	
- Permissible air pressure	1080 to 660 hPa
Mechanical and climatic conditions during operation	
Climatic conditions in operation	
• Temperature	
- Permissible temperature range	0 °C to 55 °C horizontal installation 0 °C to 45 °C vertical installation
• Air pressure acc. to IEC 60068-2-13	
- Permissible air pressure	1080 to 795 hPa
• Pollutant concentrations	
- SO ₂ at RH < 60% without condensation	SO ₂ : < 0.5 ppm; H ₂ S: < 0.1 ppm; RH < 60% condensation-free
Connection method	
required front connector	Yes
Mechanics/material	
Type of housing (front)	
• Plastic	Yes
Dimensions	
Width	45 mm
Height	100 mm
Depth	75 mm
Weight	
Weight, approx.	220 g

SIMATIC S7-1200

Analog modules

SM 1234 analog input/output modules

Ordering data

SM 1234 analog input/output signal module

4 analog inputs,
±10 V, ±5 V, ±2.5 V, or
0 ... 20 mA, 12 bits + sign;
2 analog outputs, ±10 V with 14 bits
or 0 ... 20 mA with 13 bits

Order No.

6ES7 234-4HE32-0XB0

Terminal block (spare part)

for 8/16-channel analog
signal modules

with 7 screws, gold-plated; 4 pcs.

6ES7 292-1BG30-0XA0

Extension cable for two-tier configuration

for connecting digital/analog
signal modules;
length 2 m

6ES7 290-6AA30-0XA0

Front flap set (spare part)

for 8/16-channel signal modules

6ES7 291-1BA30-0XA0

S7-1200 automation system, System Manual

for SIMATIC S7-1200 and
STEP 7 Basic

German

6ES7 298-8FA30-8AH0

English

6ES7 298-8FA30-8BH0

French

6ES7 298-8FA30-8CH0

Spanish

6ES7 298-8FA30-8DH0

Italian

6ES7 298-8FA30-8EH0

Chinese

6ES7 298-8FA30-8KH0

S7-1200 automation system, Easy Book

Brief instructions

German

6ES7 298-8FA30-8AQ0

English

6ES7 298-8FA30-8BQ0

French

6ES7 298-8FA30-8CQ0

Spanish

6ES7 298-8FA30-8DQ0

Italian

6ES7 298-8FA30-8EQ0

Chinese

6ES7 298-8FA30-8KQ0

3

Overview

- For the convenient recording of temperatures with great accuracy
- 7 common thermocouple types can be used
- Also for the measurement of analog signals with a low level (± 80 mV)
- Can easily be retrofitted to existing plant

Technical specifications

	6ES7 231-5QD30-0XB0 SM1231 TC 4x16 bit	6ES7 231-5QF30-0XB0 SM 1231 TC 8x16bit
Supply voltage 24 V DC	Yes	Yes
Input current Current consumption, typ.	40 mA	80 mA
from backplane bus 5 V DC, typ.	80 mA	80 mA
Power losses Power loss, typ.	1.5 W	1.5 W
Analog inputs Number of analog inputs	4; Thermocouples	8; Thermocouples
permissible input frequency for current input (destruction limit), max.	± 35 V	± 35 V
Technical unit for temperature measurement adjustable	Degrees Celsius/degrees Fahrenheit	Degrees Celsius/degrees Fahrenheit
Input ranges • Thermocouple	Yes; J, K, T, E, R, S, N, C, TXK/XK(L); voltage range: +/-80 mV	Yes; J, K, T, E, R, S, N, C, TXK/XK(L); voltage range: +/-80 mV
Input ranges (rated values), voltages • -80 mV to +80 mV	Yes	Yes
Input ranges (rated values), thermoelements • Type C • Type E • Type J • Type K • Type N • Type R • Type S • Type T • Type TXK/TXK(L) to GOST	Yes Yes Yes Yes Yes Yes Yes Yes Yes	Yes Yes Yes Yes Yes Yes Yes Yes Yes
Thermocouple (TC) • permissible input voltage for voltage input (destruction limit), max. • Temperature compensation - Parameterizable	+ -35V No	+ -35V No
Analog value creation Measurement principle	integrating	integrating
Integrations and conversion time/ resolution per channel • Resolution with overrange (bit including sign), max. • Integration time, parameterizable • Interference voltage suppression for interference frequency f1 in Hz	15 bit; + sign No 85 dB at 50 / 60 / 400 Hz	15 bit; + sign No 85 dB at 50 / 60 / 400 Hz

SIMATIC S7-1200

Analog modules

SM 1231 thermocouple modules

Technical specifications (continued)

	6ES7 231-5QD30-0XB0 SM1231 TC 4x16 bit	6ES7 231-5QF30-0XB0 SM 1231 TC 8x16bit
Analog value generation (in isochronous mode) Smoothing of measured values • Parameterizable	Yes	Yes
Errors/accuracies cold connection point		+/-1.5 °C
Temperature error (relative to input area)	25 °C ±0.1 % to 55 °C ±0.2 % total measurement range	25 °C ±0.1 % to 55 °C ±0.2 % total measurement range
Interference voltage suppression for $f = n \times (f_1 \pm 1\%)$, $f_1 =$ interference frequency • Common mode interference, min.	120 dB	120 dB
Interrupts/diagnostics/ status information Alarms • Alarms • Diagnostic alarm	Yes Yes	Yes Yes
Diagnostic messages • Diagnostic functions • Monitoring the supply voltage • Wire break	Yes; Can be read out Yes Yes	Yes; Can be read out Yes Yes
Diagnostics indication LED • for status of the inputs • for maintenance	Yes Yes	Yes Yes
Degree and class of protection IP20	Yes	Yes
Standards, approvals, certificates CE mark	Yes	Yes
C-TICK	Yes	Yes
FM approval	Yes	Yes
Climatic and mechanical conditions for storage and transport Climatic conditions for storage and transport • Free fall - Drop height, max. (in packaging) • Temperature - Permissible temperature range • Air pressure acc. to IEC 60068-2-13 - Permissible air pressure	0.3 m; five times, in dispatch package -40 °C to +70 °C 1080 to 660 hPa	0.3 m; five times, in dispatch package -40 °C to +70 °C 1080 to 660 hPa

Technical specifications (continued)

	6ES7 231-5QD30-0XB0 SM1231 TC 4x16 bit	6ES7 231-5QF30-0XB0 SM 1231 TC 8x16bit
Mechanical and climatic conditions during operation		
Climatic conditions in operation		
• Temperature		
- Permissible temperature range	0 °C to 55 °C horizontal installation 0 °C to 45 °C vertical installation	0 °C to 55 °C horizontal installation 0 °C to 45 °C vertical installation
• Air pressure acc. to IEC 60068-2-13		
- Permissible air pressure	1080 to 795 hPa	1080 to 795 hPa
• Pollutant concentrations		
- SO ₂ at RH < 60% without condensation	SO ₂ : < 0.5 ppm; H ₂ S: < 0.1 ppm; RH < 60% condensation-free	SO ₂ : < 0.5 ppm; H ₂ S: < 0.1 ppm; RH < 60% condensation-free
Connection method		
required front connector	Yes	Yes
Mechanics/material		
Type of housing (front)		
• Plastic	Yes	Yes
Dimensions		
Width	45 mm	45 mm
Height	100 mm	100 mm
Depth	75 mm	75 mm
Weight		
Weight, approx.	180 g	220 g

Ordering data

	Order No.		Order No.
SM 1231 thermocouple module		S7-1200 automation system, System Manual	
4 inputs +/- 80 mV, resolution 15 bits + sign, thermocouple types J, K, S, T, R, E, N	6ES7 231-5QD30-0XB0	for SIMATIC S7-1200 and STEP 7 Basic	
8 inputs +/- 80 mV, resolution 15 bits + sign, thermocouple types J, K, T, E, R, S, N, C, TXK/XK(L)	6ES7 231-5QF30-0XB0	German	6ES7 298-8FA30-8AH0
Accessories		English	6ES7 298-8FA30-8BH0
Terminal block (spare part)		French	6ES7 298-8FA30-8CH0
for 8/16-channel analog signal modules		Spanish	6ES7 298-8FA30-8DH0
with 7 screws, gold-plated; 4 pcs.	6ES7 292-1BG30-0XA0	Italian	6ES7 298-8FA30-8EH0
Extension cable for two-tier configuration		Chinese	6ES7 298-8FA30-8KH0
for connecting digital/analog signal modules; length 2 m	6ES7 290-6AA30-0XA0	S7-1200 automation system, Easy Book	
Front flap set (spare part)		Brief instructions	
for 8/16-channel signal modules	6ES7 291-1BA30-0XA0	German	6ES7 298-8FA30-8AQ0
		English	6ES7 298-8FA30-8BQ0
		French	6ES7 298-8FA30-8CQ0
		Spanish	6ES7 298-8FA30-8DQ0
		Italian	6ES7 298-8FA30-8EQ0
		Chinese	6ES7 298-8FA30-8KQ0

SIMATIC S7-1200

Analog modules

SB 1231 thermocouple signal boards

Overview

- For the convenient recording of temperatures with great accuracy
- 1 input with 16-bit resolution
- Common thermocouple types can be used
- Also for the measurement of analog signals with a low level (± 80 mV)
- Can easily be retrofitted to existing plant
- Can be plugged directly into the CPU

Technical specifications

6ES7 231-5QA30-0XB0 SB1231 AI 1xTC		6ES7 231-5QA30-0XB0 SB1231 AI 1xTC	
Supply voltage 24 V DC	Yes	Analog value generation (in isochronous mode) Smoothing of measured values • Parameterizable	Yes
Input current Current consumption, typ.	5 mA	Errors/accuracies Temperature error (relative to input area)	25 °C ± 0.1 % to 55 °C ± 0.2 % total measurement range
from backplane bus 5 V DC, typ.	20 mA	Interference voltage suppression for $f = n \times (f_1 \pm 1\%)$, $f_1 =$ interference frequency • Common mode interference, min.	120 dB
Power losses Power loss, typ.	0.5 W	Interrupts/diagnostics/ status information Alarms • Alarms • Diagnostic alarm	Yes Yes
Analog inputs Number of analog inputs	1; Thermocouples	Diagnostic messages • Diagnostic functions • Wire break	Yes; Can be read out Yes
permissible input frequency for current input (destruction limit), max.	± 35 V	Diagnostics indication LED • for status of the inputs • for maintenance	Yes Yes
Technical unit for temperature measurement adjustable	Degrees Celsius/ degrees Fahrenheit	Degree and class of protection IP20	Yes
Input ranges • Thermocouple	Yes; J, K; voltage range ± 80 MV	Standards, approvals, certificates CE mark	Yes
Input ranges (rated values), voltages • -80 mV to +80 mV	Yes	C-TICK	Yes
Input ranges (rated values), thermoelements • Type J • Input resistance (type J) • Type K • Input resistance (Type K)	Yes 1200°C Yes 1372°C	FM approval	Yes
Thermocouple (TC) • permissible input voltage for voltage input (destruction limit), max. • Temperature compensation - Parameterizable	+35V No	Climatic and mechanical conditions for storage and transport Climatic conditions for storage and transport • Free fall - Drop height, max. (in packaging)	0.3 m; five times, in dispatch package
Analog value creation Measurement principle	integrating	• Temperature - Permissible temperature range • Air pressure acc. to IEC 60068-2-13 - Permissible air pressure	-40 °C to +70 °C 1080 to 660 hPa
Integrations and conversion time/ resolution per channel • Resolution with overrange (bit including sign), max. • Integration time, parameterizable • Interference voltage suppression for interference frequency f_1 in Hz	15 bit; + sign No 85 dB at 10 / 50 / 60 / 400 Hz		

Technical specifications (continued)

	6ES7 231-5QA30-0XB0 SB1231 AI 1xTC	6ES7 231-5QA30-0XB0 SB1231 AI 1xTC
Mechanical and climatic conditions during operation		
Climatic conditions in operation		
• Temperature		
- Permissible temperature range	0 °C to 55 °C horizontal installation 0 °C to 45 °C vertical installation	
• Air pressure acc. to IEC 60068-2-13		
- Permissible air pressure	1080 to 795 hPa	
• Pollutant concentrations		
- SO ₂ at RH < 60% without condensation	SO ₂ : < 0.5 ppm; H ₂ S: < 0.1 ppm; RH < 60% condensation-free	
Connection method		
required front connector		Yes
Mechanics/material		
Type of housing (front)		
• Plastic		Yes
Dimensions		
Width		38 mm
Height		62 mm
Depth		21 mm
Weight		
Weight, approx.		35 g

Ordering data

Ordering data	Order No.	Ordering data	Order No.
SB 1231 thermocouple signal board	6ES7 231-5QA30-0XB0	S7-1200 automation system, Easy Book	
1 input +/- 80 mV, resolution 15 bits + sign, thermocouples type J, K		Brief instructions	
Accessories		German	6ES7 298-8FA30-8AQ0
Terminal block (spare part)		English	6ES7 298-8FA30-8BQ0
for signal board		French	6ES7 298-8FA30-8CQ0
with 6 screws, gold-plated; 4 pcs.	6ES7 292-1BF30-0XA0	Spanish	6ES7 298-8FA30-8DQ0
S7-1200 automation system, System Manual		Italian	6ES7 298-8FA30-8EQ0
for SIMATIC S7-1200 and STEP 7 Basic		Chinese	6ES7 298-8FA30-8KQ0
German	6ES7 298-8FA30-8AH0		
English	6ES7 298-8FA30-8BH0		
French	6ES7 298-8FA30-8CH0		
Spanish	6ES7 298-8FA30-8DH0		
Italian	6ES7 298-8FA30-8EH0		
Chinese	6ES7 298-8FA30-8KH0		

SIMATIC S7-1200

Analog modules

SM 1231 RTD signal modules

Overview

- For the convenient recording of temperatures with great accuracy
- 4 inputs
- Most popular resistance temperature detectors can be used
- Can easily be retrofitted to existing installation

Technical specifications

	6ES7 231-5PD30-0XB0 SM1231 RTD 4x16bit	6ES7 231-5PF30-0XB0 SM 1231 RTD 8x16bit
Supply voltage 24 V DC	Yes	Yes
Input current Current consumption, typ.	40 mA	90 mA
from backplane bus 5 V DC, typ.	80 mA	80 mA
Power losses Power loss, typ.	1.5 W	1.5 W
Analog inputs Number of analog inputs	4; Resistance thermometer	8; Resistance thermometer
permissible input frequency for current input (destruction limit), max.	± 35 V	± 35 V
Technical unit for temperature measurement adjustable	Degrees Celsius/degrees Fahrenheit	Degrees Celsius/degrees Fahrenheit
Input ranges • Resistance thermometer	Yes; Resistance-type transmitter: Pt10, Pt50, Pt100, Pt200, Pt500, Pt1000, Ni100, Ni120, Ni200, Ni500, Ni1000, Cu10, Cu50, Cu100, LG-Ni1000	Yes; Resistance-type transmitter: Pt10, Pt50, Pt100, Pt200, Pt500, Pt1000, Ni100, Ni120, Ni200, Ni500, Ni1000, Cu10, Cu50, Cu100, LG-Ni1000
• Resistance	Yes; 150 Ω, 300 Ω, 600 Ω	Yes; 150 Ω, 300 Ω, 600 Ω
Input ranges (rated values), resistance thermometers • Cu 10	Yes	Yes
• Input resistance (Cu 10)	10 Ω	10 Ω
• Ni 100	Yes	Yes
• Input resistance (Ni 100)	100 Ω	100 Ω
• Ni 1000	Yes	Yes
• Input resistance (Ni 1000)	1 000 Ω	1 000 Ω
• LG-Ni 1000	Yes	Yes
• Input resistance (LG-Ni 1000)	1 000 Ω	1 000 Ω
• Ni 120	Yes	Yes
• Input resistance (Ni 120)	120 Ω	120 Ω
• Ni 200	Yes	Yes
• Input resistance (Ni 200)	200 Ω	200 Ω
• Ni 500	Yes	Yes
• Input resistance (Ni 500)	500 Ω	500 Ω
• Pt 100	Yes	Yes
• Input resistance (Pt 100)	100 Ω	100 Ω
• Pt 1000	Yes	Yes
• Input resistance (Pt 1000)	1 000 Ω	1 000 Ω
• Pt 200	Yes	Yes
• Input resistance (Pt 200)	200 Ω	200 Ω
• Pt 500	Yes	Yes
• Input resistance (Pt 500)	500 Ω	500 Ω
Input ranges (rated values), resistors • 0 to 150 ohms	Yes	Yes
• 0 to 300 ohms	Yes	Yes
• 0 to 600 ohms	Yes	Yes
Thermocouple (TC) • Temperature compensation - Parameterizable	No	No

Technical specifications (continued)

	6ES7 231-5PD30-0XB0 SM1231 RTD 4x16bit	6ES7 231-5PF30-0XB0 SM 1231 RTD 8x16bit
Analog value creation		
Measurement principle	integrating	integrating
Integrations and conversion time/ resolution per channel		
• Resolution with overrange (bit including sign), max.	15 bit; + sign	15 bit; + sign
• Integration time, parameterizable	No	No
• Interference voltage suppression for interference frequency f1 in Hz	85 dB at 50 / 60 / 400 Hz	85 dB at 10 / 50 / 60 / 400 Hz
Errors/accuracies		
cold connection point		+/-1.5 °C
Temperature error (relative to input area)	25 °C ±0.1 % to 55 °C ±0.2 % total measurement range	25 °C ±0.1 % to 55 °C ±0.2 % total measurement range
Interference voltage suppression for f = n x (f1 +/- 1%), f1 = interference frequency		
• Common mode interference, min.	120 dB	120 dB
Interrupts/diagnostics/ status information		
Alarms		
• Alarms	Yes	Yes
• Diagnostic alarm	Yes	Yes
Diagnostic messages		
• Diagnostic functions	Yes; Can be read out	Yes; Can be read out
• Monitoring the supply voltage	Yes	Yes
• Wire break	Yes	Yes
Diagnostics indication LED		
• for status of the inputs	Yes	Yes
• for maintenance	Yes	Yes
Degree and class of protection		
IP20	Yes	Yes
Standards, approvals, certificates		
CE mark	Yes	Yes
C-TICK	Yes	Yes
FM approval	Yes	Yes
Climatic and mechanical conditions for storage and transport		
Climatic conditions for storage and transport		
• Free fall		
- Drop height, max. (in packaging)	0.3 m; five times, in dispatch package	0.3 m; five times, in dispatch package
• Temperature		
- Permissible temperature range	-40 °C to +70 °C	-40 °C to +70 °C
• Air pressure acc. to IEC 60068-2-13		
- Permissible air pressure	1080 to 660 hPa	1080 to 660 hPa

SIMATIC S7-1200

Analog modules

SM 1231 RTD signal modules

Technical specifications (continued)

	6ES7 231-5PD30-0XB0 SM1231 RTD 4x16bit	6ES7 231-5PF30-0XB0 SM 1231 RTD 8x16bit
Mechanical and climatic conditions during operation		
Climatic conditions in operation		
• Temperature		
- Permissible temperature range	0 °C to 55 °C horizontal installation 0 °C to 45 °C vertical installation	0 °C to 55 °C horizontal installation 0 °C to 45 °C vertical installation
• Air pressure acc. to IEC 60068-2-13		
- Permissible air pressure	1080 to 795 hPa	1080 to 795 hPa
• Pollutant concentrations		
- SO ₂ at RH < 60% without condensation	SO ₂ : < 0.5 ppm; H ₂ S: < 0.1 ppm; RH < 60% condensation-free	SO ₂ : < 0.5 ppm; H ₂ S: < 0.1 ppm; RH < 60% condensation-free
Connection method		
required front connector	Yes	Yes
Mechanics/material		
Type of housing (front)		
• Plastic	Yes	Yes
Dimensions		
Width	45 mm	70 mm
Height	100 mm	100 mm
Depth	75 mm	75 mm
Weight		
Weight, approx.	220 g	220 g

Ordering data

Ordering data	Order No.	Order No.
SM 1231 RTD signal module		
4 inputs for resistance temperature detectors Pt10/50/100/200/500/1000, Ni100/120/200/500/1000, Cu10/50/100, LG-Ni1000; resistance 150/300/600 Ohm, resolution 15 bits + sign	6ES7 231-5PD30-0XB0	
8 inputs for resistance temperature detectors Pt10/50/100/200/500/1000, Ni100/120/200/500/1000, Cu10/50/100, LG-Ni1000; resistance 150/300/600 Ohm, resolution 15 bits + sign	6ES7 231-5PF30-0XB0	
Accessories		
Terminal block (spare part)		
for 8/16-channel analog signal modules		
with 7 screws, gold-plated; 4 pcs.	6ES7 292-1BG30-0XA0	
Extension cable for two-tier configuration		
for connecting digital/analog signal modules; length 2 m	6ES7 290-6AA30-0XA0	
Front flap set (spare part)		
for 8/16-channel signal modules	6ES7 291-1BA30-0XA0	
S7-1200 automation system, System Manual		
for SIMATIC S7-1200 and STEP 7 Basic		
German		6ES7 298-8FA30-8AH0
English		6ES7 298-8FA30-8BH0
French		6ES7 298-8FA30-8CH0
Spanish		6ES7 298-8FA30-8DH0
Italian		6ES7 298-8FA30-8EH0
Chinese		6ES7 298-8FA30-8KH0
S7-1200 automation system, Easy Book		
Brief instructions		
German		6ES7 298-8FA30-8AQ0
English		6ES7 298-8FA30-8BQ0
French		6ES7 298-8FA30-8CQ0
Spanish		6ES7 298-8FA30-8DQ0
Italian		6ES7 298-8FA30-8EQ0
Chinese		6ES7 298-8FA30-8KQ0

Overview

- For the convenient recording of temperatures with great accuracy
- 1 input with 16-bit resolution
- Common resistance-type temperature detectors can be used
- Can easily be retrofitted to existing plant
- Can be plugged directly into the CPU

Technical specifications

6ES7 231-5PA30-0XB0 SB1231 AI 1xRTD		6ES7 231-5PA30-0XB0 SB1231 AI 1xRTD	
Supply voltage 24 V DC	Yes	Errors/accuracies Temperature error (relative to input area)	25 °C ±0.1 % to 55 °C ±0.2 % total measurement range
Input current Current consumption, typ.	5 mA	Interference voltage suppression for $f = n \times (f_1 \pm 1\%)$, $f_1 =$ interference frequency	120 dB
from backplane bus 5 V DC, typ.	20 mA	• Common mode interference, min.	
Power losses Power loss, typ.	0.5 W	Interrupts/diagnostics/ status information Alarms	Yes Yes
Analog inputs Number of analog inputs	1; Resistance thermometer	• Alarms	
permissible input frequency for current input (destruction limit), max.	± 35 V	• Diagnostic alarm	Yes Yes
Technical unit for temperature measurement adjustable	Degrees Celsius/ degrees Fahrenheit	Diagnostic messages	Yes; Can be read out Yes
Input ranges		• Diagnostic functions	
• Resistance thermometer	Yes; Platinum (Pt)	• Wire break	Yes
• Resistance	Yes; 150 Ω, 300 Ω, 600 Ω	Diagnostic indication LED	Yes Yes
Input ranges (rated values), voltages		• for status of the inputs	
• Input resistance (-80 mV to +80 mV)	≥ 10 MOhm	• for maintenance	
Input ranges (rated values), resistance thermometers		Degree and class of protection IP20	Yes
• Pt 100	Yes	Standards, approvals, certificates CE mark	Yes
• Input resistance (Pt 100)	100 Ω	C-TICK	Yes
• Pt 1000	Yes	FM approval	Yes
• Input resistance (Pt 1000)	1 000 Ω	Climatic and mechanical conditions for storage and transport Climatic conditions for storage and transport	0.3 m; five times, in dispatch package -40 °C to +70 °C 1080 to 660 hPa
• Pt 200	Yes	• Free fall	
• Input resistance (Pt 200)	200 Ω	- Drop height, max. (in packaging)	
• Pt 500	Yes	• Temperature	
• Input resistance (Pt 500)	500 Ω	- Permissible temperature range	
Input ranges (rated values), resistors		• Air pressure acc. to IEC 60068-2-13	
• 0 to 150 ohms	Yes	- Permissible air pressure	
• 0 to 300 ohms	Yes		
• 0 to 600 ohms	Yes		
Thermocouple (TC)			
• Temperature compensation - Parameterizable	No		
Analog value creation Measurement principle	integrating		
Integrations and conversion time/ resolution per channel			
• Resolution with overrange (bit including sign), max.	15 bit; + sign		
• Integration time, parameterizable	No		
• Interference voltage suppression for interference frequency f_1 in Hz	85 dB at 10 / 50 / 60 / 400 Hz		

SIMATIC S7-1200

Analog modules

SB 1231 RTD signal boards

Technical specifications (continued)

	6ES7 231-5PA30-0XB0 SB1231 AI 1xRTD	6ES7 231-5PA30-0XB0 SB1231 AI 1xRTD
Mechanical and climatic conditions during operation		
Climatic conditions in operation		
• Temperature		
- Permissible temperature range	0 °C to 55 °C horizontal installation 0 °C to 45 °C vertical installation	
• Air pressure acc. to IEC 60068-2-13		
- Permissible air pressure	1080 to 795 hPa	
• Pollutant concentrations		
- SO ₂ at RH < 60% without condensation	SO ₂ : < 0.5 ppm; H ₂ S: < 0.1 ppm; RH < 60% condensation-free	
Connection method		
required front connector		Yes
Mechanics/material		
Type of housing (front)		Yes
• Plastic		
Dimensions		
Width		38 mm
Height		62 mm
Depth		21 mm
Weight		
Weight, approx.		35 g

Ordering data

Ordering data	Order No.	Ordering data	Order No.
SB 1231 RTD signal board	6ES7 231-5PA30-0XB0	Accessories	
1 input for resistance temperature sensors Pt 100, Pt 200, Pt 500, Pt 1000, resolution 15 bits + sign		Terminal block (spare part)	
		for signal board	
		with 6 screws, gold-plated; 4 pcs.	6ES7 292-1BF30-0XA0
		S7-1200 automation system, System Manual	
		for SIMATIC S7-1200 and STEP 7 Basic	
		German	6ES7 298-8FA30-8AH0
		English	6ES7 298-8FA30-8BH0
		French	6ES7 298-8FA30-8CH0
		Spanish	6ES7 298-8FA30-8DH0
		Italian	6ES7 298-8FA30-8EH0
		Chinese	6ES7 298-8FA30-8KH0
		S7-1200 automation system, Easy Book	
		Brief instructions	
		German	6ES7 298-8FA30-8AQ0
		English	6ES7 298-8FA30-8BQ0
		French	6ES7 298-8FA30-8CQ0
		Spanish	6ES7 298-8FA30-8DQ0
		Italian	6ES7 298-8FA30-8EQ0
		Chinese	6ES7 298-8FA30-8KQ0

Overview



- Analog inputs for SIPLUS S7-1200
- With extremely short conversion times
- For connecting analog actuators and sensors without additional amplifiers
- Even solves more complex automation tasks
- From +60°C to +70°C, max. 50% of the inputs can be controlled simultaneously

Note:

SIPLUS extreme products are based on Siemens Industry standard products. The contents listed here were taken from the respective standard products. SIPLUS extreme-specific information was added.

3

Technical specifications

The technical data correspond to those of the based-on modules apart from the values listed in the table.

	6AG1 231-4HD30-2XB0 SM 1231 AI 4x13 bit	6AG1 231-4HD30-4XB0 SM 1231 AI 4x13 bit
Based on	6ES7 231-4HD30-0XB0	6ES7 231-4HD30-0XB0
Ambient conditions		
Extended ambient conditions		
• Relative to ambient temperature-atmospheric pressure-installation altitude	Tmin ... Tmax at 1080 hPa ... 795 hPa (-1000 m ... +2000 m) // Tmin ... (Tmax - 10K) at 795 hPa ... 658 hPa (+2000 m ... +3500 m) // Tmin ... (Tmax - 20K) at 658 hPa ... 540 hPa (+3500 m ... +5000 m)	Tmin ... Tmax at 1080 hPa ... 795 hPa (-1000 m ... +2000 m) // Tmin ... (Tmax - 10K) at 795 hPa ... 658 hPa (+2000 m ... +3500 m) // Tmin ... (Tmax - 20K) at 658 hPa ... 540 hPa (+3500 m ... +5000 m)
• Relative humidity - with condensation	100 %; Relative humidity, incl. condensation / frost permitted (no commissioning under condensation conditions)	100 %; Relative humidity, incl. condensation / frost permitted (no commissioning under condensation conditions)
• Resistance - to biologically active substances	Yes; Class 3B2 mold, fungus and dry rot spores (with the exception of fauna). The supplied connector covers must remain on the unused interfaces during operation!	Yes; Class 3B2 mold, fungus and dry rot spores (with the exception of fauna). The supplied connector covers must remain on the unused interfaces during operation!
- to chemically active substances	Yes; Class 3C4 incl. salt spray according to EN 60068-2-52 (degree of severity 3). The supplied connector covers must remain on the unused interfaces during operation!	Yes; Class 3C4 incl. salt spray according to EN 60068-2-52 (degree of severity 3). The supplied connector covers must remain on the unused interfaces during operation!
- to mechanically active substances	Yes; Class 3S4 incl. sand, dust. The supplied connector covers must remain on the unused interfaces during operation!	Yes; Class 3S4 incl. sand, dust. The supplied connector covers must remain on the unused interfaces during operation!
Climatic and mechanical conditions for storage and transport		
Climatic conditions for storage and transport		
• Free fall - Drop height, max. (in packaging)	0.3 m; five times, in dispatch package	0.3 m; five times, in dispatch package
• Temperature - Permissible temperature range	-40 °C to +70 °C	-40 °C to +70 °C
Mechanical and climatic conditions during operation		
Climatic conditions in operation		
• Temperature - Min.	-25 °C; = Tmin	0 °C; = Tmin
- max.	70 °C; = Tmax	55 °C; = Tmax

SIMATIC S7-1200

SIPLUS analog modules

SIPLUS SM 1231 analog input modules

Ordering data

Order No.

Order No.

SIPLUS SM 1231 analog input signal module

(extended temperature range and
medial exposure)

Ambient temperature range

-25 ... +70 °C,

from +60 ... +70 °C number of
simultaneously controllable inputs
and outputs max. 50%

4 analog inputs ± 10 V, ± 5 V, ± 2.5 V,
or 0 ... 20 mA; 12 bits + sign

6AG1 231-4HD30-2XB0

Ambient temperature range

0 ... +55 °C

4 analog inputs ± 10 V, ± 5 V, ± 2.5 V,
or 0 ... 20 mA; 12 bits + sign

6AG1 231-4HD30-4XB0

Accessories

See SIMATIC S7-1200
SM 1231 analog input,
page 3/74

3

Overview



- Analog outputs for SIPLUS S7-1200
- With extremely short conversion times
- For connecting analog actuators without additional amplifiers
- Even solves more complex automation tasks
- From +60 °C to +70 °C, max. 50% of the outputs can be controlled simultaneously

Note:

SIPLUS extreme products are based on Siemens Industry standard products. The contents listed here were taken from the respective standard products. SIPLUS extreme-specific information was added.

3

Technical specifications

The technical data correspond to those of the based-on modules apart from the values listed in the table.

	6AG1 232-4HB30-2XB0 SM 1232 AQ 2x14 bit	6AG1 232-4HB30-4XB0 SM 1232 AQ 2x14 bit
Based on	6ES7 232-4HB30-0XB0	6ES7 232-4HB30-0XB0
Ambient conditions		
Extended ambient conditions		
<ul style="list-style-type: none"> • Relative to ambient temperature-atmospheric pressure-installation altitude 	Tmin ... Tmax at 1080 hPa ... 795 hPa (-1000 m ... +2000 m) // Tmin ... (Tmax - 10K) at 795 hPa ... 658 hPa (+2000 m ... +3500 m) // Tmin ... (Tmax - 20K) at 658 hPa ... 540 hPa (+3500 m ... +5000 m)	Tmin ... Tmax at 1080 hPa ... 795 hPa (-1000 m ... +2000 m) // Tmin ... (Tmax - 10K) at 795 hPa ... 658 hPa (+2000 m ... +3500 m) // Tmin ... (Tmax - 20K) at 658 hPa ... 540 hPa (+3500 m ... +5000 m)
<ul style="list-style-type: none"> • Relative humidity <ul style="list-style-type: none"> - with condensation 	100 %; Relative humidity, incl. condensation / frost permitted (no commissioning under condensation conditions)	100 %; Relative humidity, incl. condensation / frost permitted (no commissioning under condensation conditions)
<ul style="list-style-type: none"> • Resistance <ul style="list-style-type: none"> - to biologically active substances - to chemically active substances - to mechanically active substances 	<p>Yes; Class 3B2 mold, fungus and dry rot spores (with the exception of fauna). The supplied connector covers must remain on the unused interfaces during operation!</p> <p>Yes; Class 3C4 incl. salt spray according to EN 60068-2-52 (degree of severity 3). The supplied connector covers must remain on the unused interfaces during operation!</p> <p>Yes; Class 3S4 incl. sand, dust. The supplied connector covers must remain on the unused interfaces during operation!</p>	<p>Yes; Class 3B2 mold, fungus and dry rot spores (with the exception of fauna). The supplied connector covers must remain on the unused interfaces during operation!</p> <p>Yes; Class 3C4 incl. salt spray according to EN 60068-2-52 (degree of severity 3). The supplied connector covers must remain on the unused interfaces during operation!</p> <p>Yes; Class 3S4 incl. sand, dust. The supplied connector covers must remain on the unused interfaces during operation!</p>
Climatic and mechanical conditions for storage and transport		
Climatic conditions for storage and transport		
<ul style="list-style-type: none"> • Free fall <ul style="list-style-type: none"> - Drop height, max. (in packaging) • Temperature <ul style="list-style-type: none"> - Permissible temperature range 	0.3 m; five times, in dispatch package -40 °C to +70 °C	0.3 m; five times, in dispatch package -40 °C to +70 °C
Mechanical and climatic conditions during operation		
Climatic conditions in operation		
<ul style="list-style-type: none"> • Temperature <ul style="list-style-type: none"> - Min. - max. 	-25 °C; = Tmin 70 °C; = Tmax	0 °C; = Tmin 55 °C; = Tmax

SIMATIC S7-1200

SIPLUS analog modules

SIPLUS SM 1232 analog output modules

Ordering data

Order No.

Order No.

SIPLUS SM 1232 analog output signal modules

(extended temperature range and
medial exposure)

Ambient temperature range

-25 ... +70 °C,

from +60 ... +70 °C number of
simultaneously controllable inputs
and outputs max. 50%

2 analog outputs, ± 10 V with 14 bits
or 0 ... 20 mA with 13 bits

6AG1 232-4HB30-2XB0

Ambient temperature range

0 ... +55 °C

2 analog outputs, ± 10 V with 14 bits
or 0 ... 20 mA with 13 bits

6AG1 232-4HB30-4XB0

Accessories

See SIMATIC S7-1200
SM 1232 analog output,
page 3/79

3

Overview



- Analog output for SIPLUS S7-1200
- Can be plugged directly into the CPU (cannot be used for +70 °C version)

Note:

SIPLUS extreme products are based on Siemens Industry standard products. The contents listed here were taken from the respective standard products. SIPLUS extreme-specific information was added.

Technical specifications

The technical data correspond to those of the based-on modules apart from the values listed in the table.

	6AG1 232-4HA30-4XB0 SB 1232 1x AO 6ES7 232-4HA30-0XB0	6AG1 232-4HA30-5XB0 SB 1232 1x AO 6ES7 232-4HA30-0XB0
Based on		
Ambient conditions Extended ambient conditions		
<ul style="list-style-type: none"> • Relative to ambient temperature-atmospheric pressure-installation altitude • Relative humidity <ul style="list-style-type: none"> - with condensation - With condensation/maximum/ tested in accordance with IEC 60068-2-38 • Resistance <ul style="list-style-type: none"> - to biologically active substances - to chemically active substances - to mechanically active substances 	<p>Tmin ... Tmax at 1080 hPa ... 795 hPa (-1000 m ... +2000 m) // Tmin ... (Tmax - 10K) at 795 hPa ... 658 hPa (+2000 m ... +3500 m) // Tmin ... (Tmax - 20K) at 658 hPa ... 540 hPa (+3500 m ... +5000 m)</p> <p>100 %; RH incl. condensation/frost (no commissioning under condensation conditions)</p> <p>Yes; Class 3B2 mold, fungus and dry rot spores (with the exception of fauna). The supplied connector covers must remain on the unused interfaces during operation!</p> <p>Yes; Class 3C4 (RH < 75%) incl. salt spray according to EN 60068-2-52 (degree of severity 3). The supplied connector covers must remain on the unused interfaces during operation!</p> <p>Yes; Class 3S4 incl. sand, dust. The supplied connector covers must remain on the unused interfaces during operation!</p>	<p>Tmin ... Tmax at 1080 hPa ... 795 hPa (-1000 m ... +2000 m) // Tmin ... (Tmax - 10K) at 795 hPa ... 658 hPa (+2000 m ... +3500 m) // Tmin ... (Tmax - 20K) at 658 hPa ... 540 hPa (+3500 m ... +5000 m)</p> <p>100 %; Relative humidity, incl. condensation / frost permitted (no commissioning under condensation conditions)</p> <p>Yes; Class 3B2 mold, fungus and dry rot spores (with the exception of fauna). The supplied connector covers must remain on the unused interfaces during operation!</p> <p>Yes; Class 3C4 incl. salt spray according to EN 60068-2-52 (degree of severity 3). The supplied connector covers must remain on the unused interfaces during operation!</p> <p>Yes; Class 3S4 incl. sand, dust. The supplied connector covers must remain on the unused interfaces during operation!</p>
Climatic and mechanical conditions for storage and transport Climatic conditions for storage and transport		
<ul style="list-style-type: none"> • Free fall <ul style="list-style-type: none"> - Drop height, max. (in packaging) • Temperature <ul style="list-style-type: none"> - Permissible temperature range 	<p>0.3 m; five times, in dispatch package</p> <p>-40 °C to +70 °C</p>	<p>0.3 m; five times, in dispatch package</p> <p>-40 °C to +70 °C</p>
Mechanical and climatic conditions during operation Climatic conditions in operation		
<ul style="list-style-type: none"> • Temperature <ul style="list-style-type: none"> - Min. - max. 	<p>0 °C; = Tmin</p> <p>55 °C; = Tmax</p>	<p>-25 °C; = Tmin</p> <p>55 °C; = Tmax</p>

SIMATIC S7-1200

SIPLUS analog modules

SIPLUS SB 1232 analog output modules

Ordering data

Order No.

SIPLUS SB 1232 analog output signal board

(extended temperature range and
medial exposure)

Ambient temperature range
-25 ... +55 °C

1 analog output, ±10 V with 12 bits
or 0 ... 20 mA with 11 bits

6AG1 232-4HA30-5XB0

Ambient temperature range
0 ... +55 °C

1 analog output, ±10 V with 12 bits
or 0 ... 20 mA with 11 bits

6AG1 232-4HA30-4XB0

Accessories

Order No.

See SIMATIC S7-1200
SB 1232 analog output,
page 3/81

3

Overview



- Analog inputs and outputs for SIPLUS S7-1200
- With extremely short conversion times
- For connecting analog actuators and sensors without additional amplifiers
- Even solves more complex automation tasks
- From +60 °C to +70 °C, max. 50% of the inputs and outputs can be controlled simultaneously

Note:

SIPLUS extreme products are based on Siemens Industry standard products. The contents listed here were taken from the respective standard products. SIPLUS extreme-specific information was added.

3

Technical specifications

The technical data correspond to those of the based-on modules apart from the values listed in the table.

	6AG1 234-4HE30-2XB0 SM 1234 A I4x13 bit AQ 2x14 bit	6AG1 234-4HE30-4XB0 SM 1234 A I4x13 bit AQ 2x14 bit
Based on	6ES7 234-4HE30-0XB0	6ES7 234-4HE30-0XB0
Ambient conditions Extended ambient conditions		
<ul style="list-style-type: none"> • Relative to ambient temperature-atmospheric pressure-installation altitude 	Tmin ... Tmax at 1080 hPa ... 795 hPa (-1000 m ... +2000 m) // Tmin ... (Tmax - 10K) at 795 hPa ... 658 hPa (+2000 m ... +3500 m) // Tmin ... (Tmax - 20K) at 658 hPa ... 540 hPa (+3500 m ... +5000 m)	Tmin ... Tmax at 1080 hPa ... 795 hPa (-1000 m ... +2000 m) // Tmin ... (Tmax - 10K) at 795 hPa ... 658 hPa (+2000 m ... +3500 m) // Tmin ... (Tmax - 20K) at 658 hPa ... 540 hPa (+3500 m ... +5000 m)
<ul style="list-style-type: none"> • Relative humidity <ul style="list-style-type: none"> - with condensation 	100 %; Relative humidity, incl. condensation / frost permitted (no commissioning under condensation conditions)	100 %; Relative humidity, incl. condensation / frost permitted (no commissioning under condensation conditions)
<ul style="list-style-type: none"> • Resistance <ul style="list-style-type: none"> - to biologically active substances - to chemically active substances - to mechanically active substances 	Yes; Class 3B2 mold, fungus and dry rot spores (with the exception of fauna). The supplied connector covers must remain on the unused interfaces during operation! Yes; Class 3C4 incl. salt spray according to EN 60068-2-52 (degree of severity 3). The supplied connector covers must remain on the unused interfaces during operation! Yes; Class 3S4 incl. sand, dust. The supplied connector covers must remain on the unused interfaces during operation!	Yes; Class 3B2 mold, fungus and dry rot spores (with the exception of fauna). The supplied connector covers must remain on the unused interfaces during operation! Yes; Class 3C4 incl. salt spray according to EN 60068-2-52 (degree of severity 3). The supplied connector covers must remain on the unused interfaces during operation! Yes; Class 3S4 incl. sand, dust. The supplied connector covers must remain on the unused interfaces during operation!
Climatic and mechanical conditions for storage and transport Climatic conditions for storage and transport		
<ul style="list-style-type: none"> • Free fall <ul style="list-style-type: none"> - Drop height, max. (in packaging) • Temperature <ul style="list-style-type: none"> - Permissible temperature range 	0.3 m; five times, in dispatch package -40 °C to +70 °C	0.3 m; five times, in dispatch package -40 °C to +70 °C
Mechanical and climatic conditions during operation Climatic conditions in operation		
<ul style="list-style-type: none"> • Temperature <ul style="list-style-type: none"> - Min. - max. 	-25 °C; = Tmin 70 °C; = Tmax	0 °C; = Tmin 55 °C; = Tmax

SIMATIC S7-1200

SIPLUS analog modules

SIPLUS SM 1234 analog input/output modules

Ordering data

Order No.

SIPLUS SM 1234 analog input/output signal modules

(extended temperature range and medial exposure)

Ambient temperature range

-25 ... +70 °C,
from +60 ... +70 °C number of simultaneously controllable inputs and outputs max. 50%

4 analog inputs, ± 10 V, ± 5 V, ± 2.5 V, or 0 ... 20 mA, 12 bits + sign;
2 analog outputs, ± 10 V with 14 bits or 0 ... 20 mA with 13 bits

6AG1 234-4HE30-2XB0

Ambient temperature range

0 ... +55 °C

4 analog inputs, ± 10 V, ± 5 V, ± 2.5 V, or 0 ... 20 mA, 12 bits + sign;
2 analog outputs, ± 10 V with 14 bits or 0 ... 20 mA with 13 bits

6AG1 234-4HE30-4XB0

Accessories

Order No.

See SIMATIC S7-1200 SM 1234 analog input/output, page 3/84

Overview



- Simulator module for program testing during commissioning and ongoing operation
- Simulation of 8 or 14 inputs

Ordering data

Digital input simulator SIM 1274 simulator module (optional)

with 8 input switches,
for CPU 1211C, CPU 1212C

with 14 input switches,
for CPU 1214C, 1215C

with 14 input switches,
for CPU 1217C

Order No.

6ES7 274-1XF30-0XA0

6ES7 274-1XH30-0XA0

6ES7 274-1XK30-0XA0

Order No.

Accessories

S7-1200 automation system, System Manual

For SIMATIC S7-1200 and
STEP 7 Basic

German

English

French

Spanish

Italian

Chinese

6ES7 298-8FA30-8AH0

6ES7 298-8FA30-8BH0

6ES7 298-8FA30-8CH0

6ES7 298-8FA30-8DH0

6ES7 298-8FA30-8EH0

6ES7 298-8FA30-8KH0

S7-1200 automation system, Easy Book

Brief instructions

German

English

French

Spanish

Italian

Chinese

6ES7 298-8FA30-8AQ0

6ES7 298-8FA30-8BQ0

6ES7 298-8FA30-8CQ0

6ES7 298-8FA30-8DQ0

6ES7 298-8FA30-8EQ0

6ES7 298-8FA30-8KQ0

SIMATIC S7-1200

Special modules

BB 1297 Battery Board

Overview

- Battery board for extending the power reserve for the S7-1200 real-time clock

Technical specifications

	6ES7 297-0AX30-0XA0 BB 1297 battery board
Interrupts/diagnostics/ status information	
Alarms	
• Alarms	Yes
Diagnostic messages	
• Diagnostic functions	Yes
Diagnosics indication LED	
• for maintenance	Yes; The maintenance LED (MAINT) of the PLC signals that the battery needs to be replaced.
Degree and class of protection	
IP20	Yes
Standards, approvals, certificates	
CE mark	Yes
CSA approval	Yes
C-TICK	Yes
FM approval	Yes
Marine approval	Yes
Marine approval according to American Bureau of Shipping	Yes
Marine approval according to Bureau Veritas	Yes
Marine approval according to Det Norske Veritas	Yes
Marine approval according to Germanischer Lloyd	Yes
Marine approval according to Lloyds Register of Shipping	Yes

6ES7 297-0AX30-0XA0 BB 1297 battery board	
Climatic and mechanical conditions for storage and transport	
Climatic conditions for storage and transport	
• Free fall	0,3 m; five times, in dispatch package
- Drop height, max. (in packaging)	
• Temperature	
- Permissible temperature range	-40 °C to +70 °C
• Air pressure acc. to IEC 60068-2-13	
- Permissible air pressure	1080 to 660 hPa
Mechanical and climatic conditions during operation	
Climatic conditions in operation	
• Temperature	
- Min.	-20 °C
- max.	60 °C
• Air pressure acc. to IEC 60068-2-13	
- Permissible air pressure	1080 to 795 hPa
Mechanics/material	
Type of housing (front)	
• Plastic	Yes
Dimensions	
Width	38 mm
Height	62 mm
Depth	21 mm
Weight	
Weight, approx.	40 g

Ordering data

BB 1297 battery board
for long-term backup of real-time clock; can be plugged into the signal board slot of an S7-1200 CPU in FW version 3.0 or higher; battery (CR 1025) is not included

Order No.

6ES7 297-0AX30-0XA0

Overview



- For quick, high-performance serial data exchange via point-to-point connection
- Implemented protocols: ASCII, USS drive protocol, Modbus RTU
- Additional protocols can also be loaded
- Simple parameterization with STEP 7 Basic

3

Technical specifications

	6ES7 241-1CH31-0XB0 CM 1241 RS422/485	6ES7 241-1AH30-0XB0 CM 1241 RS232
Supply voltage		
24 V DC	Yes	
permissible range, lower limit (DC)	20.4 V	
permissible range, upper limit (DC)	28.8 V	
Input current		
Current consumption, max.	240 mA; From L5+; logic	220 mA; From L5+; logic
Power losses		
Power loss, typ.	1.2 W	1.1 W
Interfaces		
Number of interfaces	1	1
Interface physics, RS 232C (V.24)		Yes
Interface physics, RS 422/RS 485 (X.27)	Yes	
Point-to-point		
• Cable length, max.	1 000 m	10 m
• Integrated protocol driver		
- ASCII	Yes; Available as library function	Yes
- USS	Yes; Available as library function	
Climatic and mechanical conditions for storage and transport		
Climatic conditions for storage and transport		
• Free fall		
- Drop height, max. (in packaging)	0.3 m; five times, in dispatch package	0.3 m; five times, in dispatch package
• Temperature		
- Permissible temperature range	-40 °C to +70 °C	-40 °C to +70 °C
• Air pressure acc. to IEC 60068-2-13		
- Permissible air pressure	1080 to 660 hPa	1080 to 660 hPa

SIMATIC S7-1200

Communication

CM 1241 communication modules

Technical specifications (continued)

	6ES7 241-1CH31-0XB0 CM 1241 RS422/485	6ES7 241-1AH30-0XB0 CM 1241 RS232
Mechanical and climatic conditions during operation		
Climatic conditions in operation		
• Temperature		
- Permissible temperature range	0 °C to 55 °C horizontal installation 0 °C to 45 °C vertical installation	0 °C to 55 °C horizontal installation 0 °C to 45 °C vertical installation
- Permissible temperature change	5°C to 55°C, 3°C / minute	5°C to 55°C, 3°C / minute
• Air pressure acc. to IEC 60068-2-13		
- Permissible air pressure	1080 to 795 hPa	1080 to 795 hPa
Software		
Runtime software		
• Target system		
- S7-1200	Yes	Yes
Dimensions		
Width	30 mm	30 mm
Height	100 mm	100 mm
Depth	75 mm	75 mm
Weight		
Weight, approx.	155 g	150 g

Ordering data

CM 1241 communication module

Communication module for point-to-point connection, with one RS422/485 interface

Communication module for point-to-point connection, with one RS232 interface

Order No.

6ES7 241-1CH31-0XB0

6ES7 241-1AH30-0XB0

Order No.

Accessories

Front flap set (spare part)
for communication modules

6ES7 291-1CC30-0XA0

S7-1200 automation system, System Manual

for SIMATIC S7-1200 and STEP 7 Basic

German

6ES7 298-8FA30-8AH0

English

6ES7 298-8FA30-8BH0

French

6ES7 298-8FA30-8CH0

Spanish

6ES7 298-8FA30-8DH0

Italian

6ES7 298-8FA30-8EH0

Chinese

6ES7 298-8FA30-8KH0

S7-1200 automation system, Easy Book

Brief instructions

German

6ES7 298-8FA30-8AQ0

English

6ES7 298-8FA30-8BQ0

French

6ES7 298-8FA30-8CQ0

Spanish

6ES7 298-8FA30-8DQ0

Italian

6ES7 298-8FA30-8EQ0

Chinese

6ES7 298-8FA30-8KQ0

Overview

- For fast, high-performance serial data exchange via point-to-point connection
- Implemented protocols: ASCII, USS drive protocol, Modbus RTU
- Additional protocols can be loaded later
- Simple parameterization with STEP 7 Basic
- Can be plugged directly into the CPU

Technical specifications

6ES7 241-1CH30-1XB0 CB 1241 RS485	
Input current from backplane bus 5 V DC, typ.	50 mA
Power losses Power loss, typ.	1.5 W
Interrupts/diagnostics/ status information Diagnostic messages	
• Diagnostic functions	Yes
Diagnostics indication LED	
• For status of the outputs	Yes
Degree and class of protection IP20	Yes
Standards, approvals, certificates CE mark	Yes
C-TICK	Yes
FM approval	Yes
Climatic and mechanical conditions for storage and transport Climatic conditions for storage and transport	
• Free fall	
- Drop height, max. (in packaging)	0.3 m; five times, in dispatch package
• Temperature	
- Permissible temperature range	-40 °C to +70 °C
• Air pressure acc. to IEC 60068-2-13	
- Permissible air pressure	1080 to 660 hPa
Mechanical and climatic conditions during operation Climatic conditions in operation	
• Temperature	
- Permissible temperature range	0 °C to 55 °C horizontal installation 0 °C to 45 °C vertical installation
- Permissible temperature change	5°C to 55°C, 3°C / minute
• Air pressure acc. to IEC 60068-2-13	
- Permissible air pressure	1080 to 795 hPa
• Pollutant concentrations	
- SO ₂ at RH < 60% without condensation	SO ₂ : < 0.5 ppm; H ₂ S: < 0.1 ppm; RH < 60% condensation-free
Mechanics/material Type of housing (front)	
• Plastic	Yes
Dimensions Width	38 mm
Height	62 mm
Depth	21 mm
Weight Weight, approx.	40 g

Ordering data

Order No.

CB 1241 communication board RS485 for point-to-point connection, with 1 RS485 interface	6ES7 241-1CH30-1XB0
Accessories	
Terminal block (spare part) for signal board with 6 screws, gold-plated; 4 pcs.	6ES7 292-1BF30-0XA0
S7-1200 automation system, System Manual for SIMATIC S7-1200 and STEP 7 Basic	
German	6ES7 298-8FA30-8AH0
English	6ES7 298-8FA30-8BH0
French	6ES7 298-8FA30-8CH0
Spanish	6ES7 298-8FA30-8DH0
Italian	6ES7 298-8FA30-8EH0
Chinese	6ES7 298-8FA30-8KH0
S7-1200 automation system, Easy Book Brief instructions	
German	6ES7 298-8FA30-8AQ0
English	6ES7 298-8FA30-8BQ0
French	6ES7 298-8FA30-8CQ0
Spanish	6ES7 298-8FA30-8DQ0
Italian	6ES7 298-8FA30-8EQ0
Chinese	6ES7 298-8FA30-8KQ0

SIMATIC S7-1200

Communication

CM 1242-5

Overview



DP-M	DP-S	FMS	PG/OP	S7
	●			

The CM 1242-5 communication module is used to connect a SIMATIC S7-1200 to PROFIBUS as a DP slave and has the following characteristics:

- PROFIBUS DPV1 slave in accordance with IEC 61158
- Module replacement without PG supported
- Power is supplied via the backplane bus so that no extra cabling is required
- Support of all standard baud rates from 9.6 Kbit/s to 12 Mbit/s
- Compact industry-standard enclosure in S7-1200 design for mounting on a standard mounting rail
- Fast commissioning thanks to easy configuration using STEP 7 without additional programming overhead

The CM 1242-5 is intended for use in factory automation. Low-cost PROFIBUS-based automation solutions can be created on the basis of the S7-1200 for optimal production.

Technical specifications

Order No.	6GK7 242-5DX30-0XE0
Product-type designation	CM 1242-5
Transmission rate	
Transmission rate at interface 1 in accordance with PROFIBUS	9.6 kbit/s ... 12 Mbit/s
Interfaces	
Number of electrical connections	
• at interface 1 in accordance with PROFIBUS	1
• for power supply	0
Design of electrical connection	
• at interface 1 in accordance with PROFIBUS	9-pin Sub-D socket (RS485)
• for power supply	-
Supply voltage, current consumption, power loss	
Type of voltage of supply voltage	DC
Supply voltage	
• 1 from backplane bus	5 V
• external	-
Relative positive tolerance at 24 V with DC	-
Relative negative tolerance at 24 V with DC	-
Consumed current	
• from backplane bus at 5 V for DC Typical	0.15 A
• from external supply voltage at 24 V with DC	
- typical	-
- maximum	-
Resistive loss	0.75 W

Order No.	6GK7 242-5DX30-0XE0
Product-type designation	CM 1242-5
Permitted ambient conditions	
Ambient temperature	
• for vertical installation during operating phase	0 ... 45 °C
• for horizontal installation during operating phase	0 ... 55 °C
• during storage	-40 ... +70 °C
• during transport	-40 ... +70 °C
• Comment	-
Relative humidity at 25 °C without condensation during operating maximum	95 %
Protection class IP	IP20
Design, dimensions and weight	
Module format	
Width	30 mm
Height	100 mm
Depth	75 mm
Net weight	0.115 kg
Product properties, functions, components general	
Number of units per CPU maximum	3
Number of modules note	-

Technical specifications (continued)		Ordering data	Order No.
Order No.	6GK7 242-5DX30-0XE0	CM 1242-5 communication module	
Product-type designation	CM 1242-5	Communication module for electrical connection of SIMATIC S7-1200 to PROFIBUS as a DPV1 slave	6GK7 242-5DX30-0XE0
Performance data		Accessories	
<u>Performance data open communication</u>		PROFIBUS FastConnect connector RS485	
Number of possible connections for open communication by means of SEND/RECEIVE blocks maximum	-	With 90° cable outlet; insulation displacement technology, max. transmission rate 12 Mbit/s	
Data volume as user data per connection for open communication by means of SEND/RECEIVE blocks maximum	-	<ul style="list-style-type: none"> Without PG interface With PG interface 	6ES7 972-0BA52-0XA0 6ES7 972-0BB52-0XA0
<u>Performance data PROFIBUS DP</u>		PROFIBUS FC standard cable	
Service as DP master DPV1	-	2-core bus cable, shielded, special design for fast mounting, delivery unit: max. 1000 m, minimum order 20 m, sold by the meter	6XV1 830-0EH10
Number of DP slaves on DP master usable	-	PROFIBUS FastConnect stripping tool	
<u>Amount of data</u>		Stripping tool for fast stripping of the PROFIBUS FastConnect bus cable	6GK1 905-6AA00
• of the address area of the inputs as DP master overall	-	PROFIBUS bus terminal 12M	
• of the address area of the outputs as DP master overall	-	Bus terminal for connection of PROFIBUS nodes at up to 12 Mbit/s with connecting cable	6GK1 500-0AA10
• of the address area of the inputs per DP slave	-		
• of the address area of the outputs per DP slave	-		
• of the address area of the diagnostic data per DP slave	-		
Service as DP slave			
• DPV0	Yes		
• DPV1	Yes		
<u>Amount of data</u>			
• of the address area of the inputs as DP slave overall	240 byte		
• of the address area of the outputs as DP slave overall	240 byte		
<u>Performance data S7 communication</u>			
Number of possible connections for S7 communication			
• maximum	-		
• with PG connections maximum	-		
• with PG/OP connections maximum	-		
• note	-		
<u>Performance data multi-protocol mode</u>			
Number of active connections with multi-protocol mode			
• without DP maximum	-		
• with DP maximum	-		
Product functions management, configuration			
Configuration software required			

SIMATIC S7-1200

Communication

CM 1243-2

Overview



The CM 1243-2 communication module is the AS-Interface master for the SIMATIC S7-1200 and has the following features:

- Connection of up to 62 AS-Interface slaves
- Integrated analog value transmission (Analog Profiles 7.3 and 7.4)
- Supports all AS-Interface master functions according to the AS-Interface Specification V3.0
- Indication of the operating state on the front of the device displayed via LED
- Display of operating mode, AS-Interface voltage faults, configuration faults and peripheral faults via LED behind the front flap
- Compact enclosure in the design of the SIMATIC S7-1200
- Suitable for AS-i power 24V: in combination with the optional DCM 1271 data decoupling module, a standard 24 V power supply unit can be used
- Configuration and diagnostics via the TIA portal

Design

The CM 1243-2 communication module is positioned to the left of the S7-1200 CPU and linked to the S7-1200 via lateral contacts.

It has:

Terminals for two AS-i cables (internally jumpered) via two screw terminals each respectively

- One terminal for connection to the functional ground
- LEDs for indication of the operating state and fault statuses of the connected slaves
- The screw terminals (included in scope of supply) can be removed to facilitate installation.

Function

The CM 1243-2 supports all specified functions of the AS-Interface Specification V3.0.

The values of the digital AS-i slaves can be activated via the process image of the S7-1200. During configuration of the slaves in the TIA Portal, the values of the analog AS-i slaves can also be reached via process image transfer.

It is also possible to exchange all data of the AS-i master and the connected AS-i slaves with the S7-1200 via the data record interface.

Changeover of the operating mode, automatic application of the slave configuration and the re-addressing of a connected AS-i slave can be implemented via the control panel of the CM 1243-2 in the TIA portal.

The optional DCM 1271 data decoupling module has an integrated recognition unit for detecting ground faults on the AS-Interface cable. The integrated overload protection also disconnects the AS-Interface cable if the drive power required exceeds 4 A.

Notes on safety

The use of this product requires suitable protective measures (e. g. network segmentation for IT security among others) in order to ensure safe plant operation, see <http://www.siemens.com/industrialsecurity>.

Configuration

To configure CM 1243-2, you require STEP 7 starting with V11 SP 2 or higher.

Below version STEP 7 V11 you also require the hardware support package for the CM 1243-2, which can be obtained via Siemens Internet Service & Support.

The software enables user-friendly configuration and diagnostics of the AS-i master and any connected slaves.

Alternatively, you can also apply the AS-Interface ACTUAL configuration at the "touch of a button" via the control panel integrated in the TIA portal/STEP7.

Ordering data	Order No.
CM 1243-2 communication module <ul style="list-style-type: none"> • AS-Interface masters for SIMATIC S7-1200 • Corresponds to AS-Interface Specification V3.0 • Dimensions (W × H × D / mm): 30 × 100 × 75 	3RK7 243-2AA30-0XB0
Accessories	
DCM 1271 data decoupling module <ul style="list-style-type: none"> • Optional, for AS-i Power24V when using a standard 24 V power supply • Dimensions (W × H × D / mm): 30 × 100 × 75 	3RK7 271-1AA30-0AA0
5-pole screw terminal for AS-i CM 1243-2 master and AS-i DCM 1271 data decoupling module <ul style="list-style-type: none"> • Screw terminals • As spare part (included in scope of delivery for CM / DCM) 	3RK1 901-3MA00
3-pole screw terminal for AS-i DCM 1271 data decoupling module for connection to power supply <ul style="list-style-type: none"> • Screw terminals • As spare part (included in scope of delivery for CM / DCM) 	3RK1 901-3MB00
Manuals <p>Manual AS-i master CM 1243-2 and AS-i data decoupling module DCM 1271 for SIMATIC S7-1200 Free download on the Internet at http://support.automation.siemens.com/WW/view/en/57358958/0/de</p> <p>German</p> <p>English</p>	3ZX1012-0RK71-1AB1 3ZX1012-0RK71-1AC1

Overview



DP-M	DP-S	FMS	PG/OP	S7
●			●	●

The CM 1243-5 communication module is used to connect a SIMATIC S7-1200 to PROFIBUS as a DP master and has the following characteristics:

- PROFIBUS DPV1 master in accordance with IEC 61158
- Support of up to 16 PROFIBUS DP slaves
- Communication with other S7 controllers based on S7 communication
- Allows the connection of programming devices and operator panels with a PROFIBUS interface to the S7-1200
- Module replacement without PG supported
- Support of all standard baud rates from 9.6 Kbit/s to 12 Mbit/s
- Compact industry-standard enclosure in S7-1200 design for mounting on a standard mounting rail
- Fast commissioning thanks to easy configuration using STEP 7 without additional programming overhead

The CM 1243-5 is intended for use in factory automation. Low-cost PROFIBUS-based automation solutions can be created on the basis of the S7-1200 for optimal production.

3

Technical specifications

Order No.	6GK7 243-5DX30-0XE0
Product-type designation	CM 1243-5
Transmission rate	
Transmission rate at interface 1 in accordance with PROFIBUS	9.6 kbit/s ... 12 Mbit/s
Interfaces	
Number of electrical connections	
• at interface 1 in accordance with PROFIBUS	1
• for power supply	1
Design of electrical connection	
• at interface 1 in accordance with PROFIBUS	9-pin Sub-D socket (RS485)
• for power supply	
Supply voltage, current consumption, power loss	
Type of voltage of supply voltage	DC
Supply voltage	
• external	24 V
Relative positive tolerance at 24 V with DC	20 %
Relative negative tolerance at 24 V with DC	20 %
Consumed current	
• from external supply voltage at 24 V with DC	
- typical	0.1 A
Resistive loss	2.4 W

Order No.	6GK7 243-5DX30-0XE0
Product-type designation	CM 1243-5
Permitted ambient conditions	
Ambient temperature	
• for vertical installation during operating phase	0 ... 45 °C
• for horizontal installation during operating phase	0 ... 55 °C
• during storage	-40 ... +70 °C
• during transport	-40 ... +70 °C
Relative humidity at 25 °C without condensation during operating maximum	95 %
Protection class IP	IP20
Design, dimensions and weight	
Module format	
Width	30 mm
Height	100 mm
Depth	75 mm
Net weight	0.134 kg
Product properties, functions, components general	
Number of modules	
• per CPU maximum	1

SIMATIC S7-1200

Communication

CM 1243-5

Technical specifications (continued)

Order No.	6GK7 243-5DX30-0XE0
Product-type designation	CM 1243-5
Performance data	
<u>Performance data PROFIBUS DP</u>	
Service as DP master DPV1	Yes
Number of DP slaves on DP master usable	16
Amount of data	
• of the address area of the inputs as DP master overall	512 byte
• of the address area of the outputs as DP master overall	512 byte
• of the address area of the inputs per DP slave	244 byte
• of the address area of the outputs per DP slave	244 byte
• of the address area of the diagnostic data per DP slave	240 byte
Service as DP slave	
• DPV0	No
• DPV1	No
<u>Performance data S7 communication</u>	
Number of possible connections for S7 communication	
• maximum	8
• with PG connections maximum	1
• with PG/OP connections maximum	3
• note	max. 4 connections to other S7 stations
<u>Performance data multi-protocol mode</u>	
Number of active connections with multi-protocol mode	
• without DP maximum	8
• with DP maximum	8
Product functions management, configuration	
Configuration software required	

Ordering data

Order No.

CM 1243-5 communication module	6GK7 243-5DX30-0XE0
Communication module for electrical connection of SIMATIC S7-1200 to PROFIBUS as a DPV1 master	
Accessories	
PROFIBUS FastConnect connector RS485	
With 90° cable outlet; insulation displacement technology, max. transmission rate 12 Mbit/s	
• Without PG interface	6ES7 972-0BA52-0XA0
• With PG interface	6ES7 972-0BB52-0XA0
PROFIBUS FC standard cable	
2-core bus cable, shielded, special design for fast mounting, delivery unit: max. 1000 m, minimum order 20 m, sold by the meter	6XV1 830-0EH10
PROFIBUS FastConnect stripping tool	
Stripping tool for fast stripping of the PROFIBUS FastConnect bus cable	6GK1 905-6AA00
PROFIBUS bus terminal 12M	
Bus terminal for connection of PROFIBUS nodes at up to 12 Mbit/s with connecting cable	6GK1 500-0AA10

Overview



- Unmanaged switch for connecting a SIMATIC S7-1200 to an Industrial Ethernet network with a line, tree or star topology
- Multiplication of Ethernet interfaces on a SIMATIC S7-1200 for additional connection of up to three programming devices, operator controls, and further Ethernet nodes
- Simple, space-saving mounting on the SIMATIC S7-1200 mounting rail
- Low-cost solution for implementing small, local Ethernet networks
- Connection without any problems using RJ45 standard connectors
- Simple and fast status display via LEDs on the device
- Integral autocrossover function permits use of uncrossed connecting cables

Technical specifications

Order No.	6GK7 277-1AA10-0AA0
Product-type designation	CSM 1277
Transmission rate	
Transfer rate 1	10 Mbit/s
Transfer rate 2	100 Mbit/s
Interfaces	
Number of electrical/optical connections for network components or terminal equipment maximum	4
Number of electrical connections	4
• for network components and terminal equipment	4
• for power supply	1
Design of electrical connection	RJ45 port
• for network components and terminal equipment	RJ45 port
• for power supply	3-pole terminal block
Supply voltage, current consumption, power loss	
Type of voltage of supply voltage	DC
Supply voltage external	24 V
• minimum	19.2 V
• maximum	28.8 V
Product component fusing at power supply input	Yes
Type of fusing at input for supply voltage	0,5 A / 60 V
Consumed current maximum	0.07 A
Active power loss at 24 V for DC	1.6 W
Permitted ambient conditions	
Ambient temperature	0 ... 60 °C
• during operating	0 ... 60 °C
• during storage	-40 ... +70 °C
• during transport	-40 ... +70 °C
Relative humidity at 25 °C without condensation during operating maximum	95 %
Protection class IP	IP20

Order No.	6GK7 277-1AA10-0AA0
Product-type designation	CSM 1277
Design, dimensions and weight	
Design	SIMATIC S7-1200 device design
Width	45 mm
Height	100 mm
Depth	75 mm
Net weight	0.15 kg
Type of mounting	
• 35 mm DIN rail mounting	Yes
• wall mounting	Yes
• S7-300 rail mounting	No
Product functions management, configuration	
Product function switch-managed	No
Standards, specifications, approvals	
Standard	
• for EMC from FM	FM3611: Class 1, Division 2, Group A, B, C, D / T., CL.1, Zone 2, GP. IIC, T. Ta
• for hazardous zone	EN 600079-15:2005, EN 600079-0:2006, II 3 G Ex nA II T4, KEMA 08 ATEX 0003 X
• for safety of CSA and UL	UL 508, CSA C22.2 No. 142
• for hazardous area of CSA and UL	-
• for emitted interference	EN 61000-6-4 (Class A)
• for interference immunity	EN 61000-6-2
Verification of suitability	EN 61000-6-2, EN 61000-6-4
• CE mark	Yes
• C-Tick	Yes
• KC approval	No

SIMATIC S7-1200

Communication

CSM 1277 unmanaged

Ordering data

CSM 1277 compact switch module

Unmanaged switch for connecting a SIMATIC S7-1200 and up to three further nodes to Industrial Ethernet with 10/100 Mbit/s; 4 x RJ45 ports; external 24 V DC power supply, diagnostics on LEDs, S7-1200 module including electronic manual on CD-ROM

Order No.

6GK7 277-1AA10-0AA0

Order No.

Accessories

IE TP Cord RJ45/RJ45

TP cable 4 x 2
with 2 RJ45 connectors

- 0.5 m
- 1 m
- 2 m
- 6 m
- 10 m

6XV1 870-3QE50
6XV1 870-3QH10
6XV1 870-3QH20
6XV1 870-3QH60
6XV1 870-3QN10

IE FC Outlet RJ45

For connecting Industrial Ethernet FC cables and TP cords; graduated prices for 10 and 50 units or more

6GK1 901-1FC00 0AA0

Overview



The CP 1242-7 communications processor is used to connect a SIMATIC S7-1200 to the globally widespread GSM/GPRS mobile radio network and has the following characteristics:

- Worldwide wireless exchange of data between S7-1200 controllers and/or between S7-1200 controllers and control centers with an Internet connection
- Communication based on the GPRS (**G**eneral **P**acket **R**adio **S**ervice) mobile wireless service with data transmission speeds of up to 86 Kbit/s in the downlink and 43 Kbit/s in the uplink
- GPRS mode with fixed IP addresses and dynamic IP addresses with standard mobile phone contract
- Time synchronization on the basis of NTP (**N**etwork **T**ime **P**rotocol)
- On-demand connection buildup via voice call or text message
- Sending and receiving of text messages
- Clearly laid out LED signaling for fast and easy diagnostics
- Compact industrial enclosure in S7-1200 design for mounting on a standard mounting rail
- Fast commissioning thanks to easy configuration using STEP 7

In conjunction with the "Telecontrol Server Basic" software, the CP 1242-7 forms a telecontrol system with further properties:

- Connection of up to 5000 telecontrol stations to the control center via an OPC interface
- Data buffering in the substations in the event of connection failures
- Central status monitoring of the substations
- No special provider services required for fixed IP addresses
- Teleservice access with STEP 7 to the substations via the Internet

Technical specifications

Order No.	6GK7 242-7KX30-0XE0
Product-type designation	CP 1242-7
Transmission rate	
Transfer rate with GPRS transmission	
• with uplink maximum	43 kbit/s
• with downlink maximum	86 kbit/s
Wireless technology	
Type of mobile wireless service	
• is supported	
- SMS	Yes
- GPRS	Yes
• note	GPRS (multislot Class 10)
Type of mobile wireless network is supported	
• GSM	Yes
• UMTS	No
Operating frequency	
• 850 MHz	Yes
• 900 MHz	Yes
• 1800 MHz	Yes
• 1900 MHz	Yes
Transmit power	
• at operating frequency 850 MHz	2 W
• at operating frequency 900 MHz	2 W
• at operating frequency 1800 MHz	1 W
• at operating frequency 1900 MHz	1 W
Interfaces	
Number of electrical connections	
• for external antenna(s)	1
• for power supply	1
Number of slots for SIM cards	1
Design of the electrical connection	
• for external antenna(s)	SMA socket (50 ohms)
• for power supply	
Design of slot for SIM card	Slot under front flap
Supply voltage, current consumption, power loss	
Type of voltage of supply voltage	DC
Supply voltage external	24 V
Relative positive tolerance at 24 V with DC	20 %
Relative negative tolerance at 24 V with DC	20 %
Consumed current from external supply voltage at 24 V with DC	
• typical	0.1 A
• maximum	0.22 A
Resistive loss	2.4 W

SIMATIC S7-1200

Communication

CP 1242-7 GPRS module

Technical specifications (continued)

Order No.	6GK7 242-7KX30-0XE0
Product-type designation	CP 1242-7
Permitted ambient conditions	
Ambient temperature	
• for vertical installation during operating phase	0 ... 45 °C
• for horizontal installation during operating phase	0 ... 55 °C
• during storage	-40 ... +70 °C
• during transport	-40 ... +70 °C
Relative humidity at 25 °C without condensation during operating maximum	95 %
Protection class IP	IP20
Design, dimensions and weight	
Module format	
Width	30 mm
Height	100 mm
Depth	75 mm
Net weight	0.133 kg
Product properties, functions, components general	
Number of modules	
• per CPU maximum	3
Performance data	
<u>Performance data open communication</u>	
Number of possible connections for open communication by means of TC blocks maximum	5
Data volume as user data per polling maximum	1 024 byte

Order No.	6GK7 242-7KX30-0XE0
Product-type designation	CP 1242-7
Performance data telecontrol	
Connection to the control center	Telecontrol Server Basic
• note	Connection to Scada system using OPC interface supported
• by means of a permanent connection	supported
• by means of a demand-oriented connection	supported
Protocol is supported	
• DNP3	No
• IEC 60870-5	No
Product function data buffering if connection is aborted	Yes
• note	up to 1000 message frames
Data volume as user data per station in telecontrol mode maximum	2 048 byte
Performance data Teleservice	
Diagnostic function online diagnostics with SIMATIC STEP 7	Yes
Product function program download with SIMATIC STEP 7	Yes
Product function remote firmware update	No
Product functions management, configuration	
Configuration software required	
Product functions Security	
Product function password protection for teleservice access	Yes
Product function encrypted data transmission	Yes
Product functions Time	
Protocol is supported NTP	Yes

Ordering data

Order No.	Order No.
Communications processor CP 1242-7¹⁾	6GK7 242-7KX30-0XE0
Communications processor for connecting SIMATIC S7-1200 to GSM/GPRS mobile wireless network	
Accessories	
Telecontrol Server Basic	
Software for	
• License for up to 8 stations	6NH9 910-0AA20-0AA0
• License for up to 32 stations	6NH9 910-0AA20-0AF0
• License for up to 64 stations	6NH9 910-0AA20-0AB0
• License for up to 256 stations	6NH9 910-0AA20-0AC0
• License for up to 1000 stations	6NH9 910-0AA20-0AD0
• License for up to 5000 stations	6NH9 910-0AA20-0AE0

Order No.	Order No.
ANT794-4MR antenna	6NH9 860-1AA00
Omnidirectional antenna for GSM (2G) and UMTS (3G) networks; weather-resistant for indoor and outdoor use; 5 m cable with fixed connection to antenna; SMA connector; including mounting bracket, screws, wall plugs	
ANT794-3M antenna	6NH9 870-1AA00
Flat panel antenna for GSM (2G) networks, for triband with 900/1800/1900 MHz; weather-resistant for indoor/outdoor use, 1.2 m cable with fixed connection to antenna; SMA connector, incl. assembly adhesive tape	

¹⁾ Please note national approvals under <http://www.siemens.com/wireless-approvals>

Overview



- For fast, high-performance serial data exchange via point-to-point coupling
- Implemented protocols: ASCII, USS drive protocol, Modbus RTU
- Additional protocols can also be loaded
- Simple parameterization with STEP 7 Basic

Note:

SIPLUS extreme products are based on Siemens Industry standard products. The contents listed here were taken from the respective standard products. SIPLUS extreme-specific information was added.

3

Technical specifications

The technical data correspond to those of the based-on modules apart from the values listed in the table.

	6AG1 241-1AH30-2XB0 CM 1241 RS232	6AG1 241-1AH30-4XB0 CM 1241 RS232	6AG1 241-1CH31-2XB0 CM 1241 RS422/485	6AG1 241-1CH31-4XB0 CM 1241 RS422/485
Based on	6ES7 241-1AH30-0XB0	6ES7 241-1AH30-0XB0	6ES7 241-1CH31-0XB0	6ES7 241-1CH31-0XB0
Ambient conditions				
Extended ambient conditions				
• Relative to ambient temperature-atmospheric pressure-installation altitude	Tmin ... Tmax at 1080 hPa ... 795 hPa (-1000 m ... +2000 m) // Tmin ... (Tmax - 10K) at 795 hPa ... 658 hPa (+2000 m ... +3500 m) // Tmin ... (Tmax - 20K) at 658 hPa ... 540 hPa (+3500 m ... +5000 m)	Tmin ... Tmax at 1080 hPa ... 795 hPa (-1000 m ... +2000 m) // Tmin ... (Tmax - 10K) at 795 hPa ... 658 hPa (+2000 m ... +3500 m) // Tmin ... (Tmax - 20K) at 658 hPa ... 540 hPa (+3500 m ... +5000 m)	Tmin ... Tmax at 1080 hPa ... 795 hPa (-1000 m ... +2000 m) // Tmin ... (Tmax - 10K) at 795 hPa ... 658 hPa (+2000 m ... +3500 m) // Tmin ... (Tmax - 20K) at 658 hPa ... 540 hPa (+3500 m ... +5000 m)	Tmin ... Tmax at 1080 hPa ... 795 hPa (-1000 m ... +2000 m) // Tmin ... (Tmax - 10K) at 795 hPa ... 658 hPa (+2000 m ... +3500 m) // Tmin ... (Tmax - 20K) at 658 hPa ... 540 hPa (+3500 m ... +5000 m)
• Relative humidity - with condensation	100 %; Relative humidity, incl. condensation / frost permitted (no commissioning under condensation conditions)	100 %; Relative humidity, incl. condensation / frost permitted (no commissioning under condensation conditions)	100 %; RH incl. condensation/frost (no commissioning under condensation conditions)	100 %; RH incl. condensation/frost (no commissioning under condensation conditions)
• Resistance - to biologically active substances	Yes; Class 3B2 mold, fungus and dry rot spores (with the exception of fauna). The supplied connector covers must remain on the unused interfaces during operation!	Yes; Class 3B2 mold, fungus and dry rot spores (with the exception of fauna). The supplied connector covers must remain on the unused interfaces during operation!	Yes; Class 3B2 mold, fungus and dry rot spores (with the exception of fauna). The supplied connector covers must remain on the unused interfaces during operation!	Yes; Class 3B2 mold, fungus and dry rot spores (with the exception of fauna). The supplied connector covers must remain on the unused interfaces during operation!
- to chemically active substances	Yes; Class 3C4 incl. salt spray according to EN 60068-2-52 (degree of severity 3). The supplied connector covers must remain on the unused interfaces during operation!	Yes; Class 3C4 incl. salt spray according to EN 60068-2-52 (degree of severity 3). The supplied connector covers must remain on the unused interfaces during operation!	Yes; Class 3C4 (RH < 75%) incl. salt spray according to EN 60068-2-52 (degree of severity 3). The supplied connector covers must remain on the unused interfaces during operation!	Yes; Class 3C4 (RH < 75%) incl. salt spray according to EN 60068-2-52 (degree of severity 3). The supplied connector covers must remain on the unused interfaces during operation!
- to mechanically active substances	Yes; Class 3S4 incl. sand, dust. The supplied plug covers must remain in place over the unused interfaces during operation!	Yes; Class 3S4 incl. sand, dust. The supplied plug covers must remain in place over the unused interfaces during operation!	Yes; Class 3S4 incl. sand, dust. The supplied plug covers must remain in place over the unused interfaces during operation!	Yes; Class 3S4 incl. sand, dust. The supplied plug covers must remain in place over the unused interfaces during operation!

SIMATIC S7-1200

SIPLUS communication

SIPLUS CM 1241 communication modules

Technical specifications (continued)

	6AG1 241-1AH30-2XB0 CM 1241 RS232	6AG1 241-1AH30-4XB0 CM 1241 RS232	6AG1 241-1CH31-2XB0 CM 1241 RS422/485	6AG1 241-1CH31-4XB0 CM 1241 RS422/485
Based on	6ES7 241-1AH30-0XB0	6ES7 241-1AH30-0XB0	6ES7 241-1CH31-0XB0	6ES7 241-1CH31-0XB0
Climatic and mechanical conditions for storage and transport Climatic conditions for storage and transport				
• Free fall - Drop height, max. (in packaging)	0.3 m; five times, in dispatch package	0.3 m; five times, in dispatch package	0.3 m; five times, in dispatch package	0.3 m; five times, in dispatch package
• Temperature - Permissible temperature range	-40 °C to +70 °C	-40 °C to +70 °C	-40 °C to +70 °C	-40 °C to +70 °C
• Relative humidity - Permissible range (without condensation) at 25 °C				95 %
Mechanical and climatic conditions during operation Climatic conditions in operation				
• Temperature - Permissible temperature range				0 °C to 55 °C horizontal installation 0 °C to 45 °C vertical installation
- Min.	-25 °C; = Tmin	0 °C; = Tmin	-25 °C	
- max.	70 °C; = Tmax	55 °C; = Tmax	70 °C; Tmax > 55 °C derating: Max. one module may be configured; this module must be the last module on the CM bus; minimum clearance on the left side of at least 45 mm	
- Permissible temperature change		5°C to 55°C, 3°C / minute		5°C to 55°C, 3°C / minute

Ordering data

SIPLUS CM 1241 communication module

(extended temperature range and medial exposure)

Ambient temperature -25 ... +70 °C

Communication module for point-to-point connection, with one RS485 interface

Communication module for point-to-point connection, with one RS232 interface

Order No.

6AG1 241-1CH30-2XB0

6AG1 241-1AH30-2XB0

Order No.

Suitable for areas with extraordinary medial exposure (conformal coating)

Communication module for point-to-point connection, with one RS485 interface

Communication module for point-to-point connection, with one RS232 interface

Accessories

6AG1 241-1CH31-4XB0

6AG1 241-1AH31-4XB0

See SIMATIC S7-1200 CM 1241 communication module, page 3/106

SIPLUS CM 1242-5 communication modules

Overview



DP-M	DP-S	FMS	PG/OP	S7
	●			

The SIPLUS CM 1242-5 communication module is used to connect a SIMATIC S7-1200 to PROFIBUS as a DP slave and has the following characteristics:

- PROFIBUS DPV1 slave in accordance with IEC 61158
- Module replacement without PG supported
- Power is supplied via the backplane bus so that no extra cabling is required
- Support of all standard baud rates from 9.6 Kbit/s to 12 Mbit/s
- Compact industry-standard enclosure in S7-1200 design for mounting on a standard mounting rail
- Fast commissioning thanks to easy configuration using STEP 7 without additional programming overhead

The CM 1242-5 is intended for use in factory automation. Low-cost PROFIBUS-based automation solutions can be created on the basis of the S7-1200 for optimal production.

Note:

SIPLUS extreme products are based on Siemens Industry standard products. The contents listed here were taken from the respective standard products. SIPLUS extreme specific information was added.

SIPLUS S7-1200 CM 1242-5	
Order No.	6AG1 242-5DX30-2XE0
Order number based on	6GK7 242-5DX30-0XE0
Ambient temperature range	-25 ... +70 °C
Ambient conditions	Suitable for exceptional exposure to media (e.g. sulfur chlorine atmosphere).
Technical data	The technical data of the standard product applies except for the ambient conditions.

Ambient conditions

Relative humidity	100%, condensation/frost permissible. No commissioning if condensation present.
Biologically active substances, compliance with EN 60721-3-3	Class 3B2 mold and fungal spores (excluding fauna). The supplied plug covers must remain in place over the unused interfaces during operation!
Chemically active substances, compliance with EN 60721-3-3	Class 3C4 incl. salt spray in accordance with EN60068-2-52 (degree of severity 3). The supplied plug covers must remain in place over the unused interfaces during operation!
Mechanically active substances, compliance with EN 60721-3-3	Class 3S4 incl. sand, dust. The supplied plug covers must remain in place over the unused interfaces during operation!
Air pressure (depending on the highest positive temperature range specified)	1 080 ... 795 hPa (-1 000 ... +2 000 m) see ambient temperature range 795 ... 658 hPa (+2 000 ... +3 500 m) derating 10 K 658 ... 540 hPa (+3 500 ... +5 000 m) derating 20 K

For technical documentation on SIPLUS, see:
<http://www.siemens.com/siplus-extreme>

Ordering data	Order No.
SIPLUS CM 1242-5 communication module (extended temperature range and medial exposure) Communication module for electrical connection of SIMATIC S7-1200 to PROFIBUS as a DPV1 slave	6AG1 242-5DX30-2XE0
Accessories	
	See SIMATIC S7-1200 CM 1242-5 communication module, page 3/109

SIMATIC S7-1200

SIPLUS communication

SIPLUS CM 1243-5 communication modules

Overview



DP-M	DP-S	FMS	PG/OP	S7
●			●	●

The CM 1243-5 communication module is used to connect a SIMATIC S7-1200 to PROFIBUS as a DP master and has the following characteristics:

- PROFIBUS DPV1 master in accordance with IEC 61158
- Support of up to 16 PROFIBUS DP slaves
- Communication with other S7 controllers based on S7 communication
- Allows the connection of programming devices and operator panels with a PROFIBUS interface to the S7-1200
- Module replacement without PG supported
- Support of all standard baud rates from 9.6 Kbit/s to 12 Mbit/s
- Compact industry-standard enclosure in S7-1200 design for mounting on a standard mounting rail
- Fast commissioning thanks to easy configuration using STEP 7 without additional programming overhead

The CM 1243-5 is intended for use in factory automation. Low-cost PROFIBUS-based automation solutions can be created on the basis of the S7-1200 for optimal production.

Note:

SIPLUS extreme products are based on Siemens Industry standard products. The contents listed here were taken from the respective standard products. SIPLUS extreme specific information was added.

SIPLUS S7-1200 CM 1243-5	
Order No.	6AG1 243-5DX30-2XE0
Order number based on	6GK7 243-5DX30-0XE0
Ambient temperature range	-25 ... +70 °C
Ambient conditions	Suitable for exceptional exposure to media (e.g. sulfur chlorine atmosphere).
Technical data	The technical data of the standard product applies except for the ambient conditions.

Ambient conditions

Relative humidity	100%, condensation/frost permissible. No commissioning if condensation present.
Biologically active substances, compliance with EN 60721-3-3	Class 3B2 mold and fungal spores (excluding fauna). The supplied plug covers must remain in place over the unused interfaces during operation!
Chemically active substances, compliance with EN 60721-3-3	Class 3C4 incl. salt spray in accordance with EN60068-2-52 (degree of severity 3). The supplied plug covers must remain in place over the unused interfaces during operation!
Mechanically active substances, compliance with EN 60721-3-3	Class 3S4 incl. sand, dust. The supplied plug covers must remain in place over the unused interfaces during operation!
Air pressure (depending on the highest positive temperature range specified)	1 080 ... 795 hPa (-1 000 ... +2 000 m) see ambient temperature range 795 ... 658 hPa (+2 000 ... +3 500 m) derating 10 K 658 ... 540 hPa (+3 500 ... +5 000 m) derating 20 K

For technical documentation on SIPLUS, see: <http://www.siemens.com/siplus-extreme>

Ordering data	Order No.
SIPLUS CM 1243-5 communication module (extended temperature range and medial exposure) Communication module for electrical connection of SIMATIC S7-1200 to PROFIBUS as a DPV1 master	6AG1 243-5DX30-2XE0
Accessories	see SIMATIC S7-1200 CM 1243-5 communication module, page 3/112

Overview



The power supply PM1207 (Power Module) is optimized for the new SIMATIC S7-1200 controllers in terms of design and functionality and serves as an external supply for the inputs and outputs which, to prevent an imbalance, must not be drawn from the CPU encoder supply.

3

Technical specifications

Order No.	6EP1 332-1SH71
Product	S7-1200 PM1207
Power supply, type	24 V/2.5 A
Input	
Input	1-phase AC
Supply voltage	120 V
• 1 at AC nominal value	230 V
• 2 at AC nominal value	Automatic range selection
• Note	
Input voltage	
• 1 at AC	85 ... 132 V
• 2 at AC	176 ... 264 V
Oversvoltage resistance	$2.3 \times V_{in}$ rated, 1.3 ms
Mains buffering at I _{out} rated, min.	20 ms
Mains buffering	at $V_{in} = 93/187$ V
Rated line frequency	
• 1	50 Hz
• 2	60 Hz
Rated line range	47 ... 63 Hz
Input current	
• at nominal level of the input voltage 120 V nominal value	1.2 A
• at nominal level of the input voltage 230 V nominal value	0.67 A
Switch-on current limiting (+25 °C), max.	13 A
Duration of current limiting at 25 °C maximum	3 ms
I ² t, max.	0.5 A ² ·s
Built-in incoming fuse	T 3, 15 A/250 V (not accessible)
Protection in the mains power input (IEC 898)	Recommended miniature circuit breaker: 16 A, characteristic B, or 10 A, characteristic C

Order No.	6EP1 332-1SH71
Product	S7-1200 PM1207
Power supply, type	24 V/2.5 A
Output	
Output	Controlled, isolated DC voltage
Rated voltage V _{out} DC	24 V
Total tolerance, static ±	3 %
Static mains compensation, approx.	0.1 %
Static load balancing, approx.	0.2 %
Residual ripple peak-peak, max.	150 mV
Spikes peak-peak, max. (bandwidth: 20 MHz)	240 mV
Product feature output voltage adjustable	No
Output voltage setting	-
Status display	Green LED for 24 V OK
On/off behavior	No overshoot of V _{out} (soft start)
Startup delay, max.	6 s
Note	2 s at 230 V, 6 s at 120 V
Voltage rise, typ.	10 ms
Rated current value I _{out} rated	2.5 A
Current range	0 ... 2.5 A
delivered active power typ.	60 W
short-term overload current at short-circuit during run-up typical	6 A
Duration of overloading ability for excess current on short-circuiting during the start-up	100 ms
short-term overload current at short-circuit during operation typical	6 A
Duration of overloading ability for excess current on short-circuiting during the operational phase	100 ms
Parallel switching for enhanced performance	Yes
Numbers of parallel switchable units for enhanced performance	2

SIMATIC S7-1200

Power supplies

SIMATIC S7-1200 PM 1207

Technical specifications (continued)

Order No.	6EP1 332-1SH71
Product	S7-1200 PM1207
Power supply, type	24 V/2.5 A
Efficiency	
Efficiency at V_{out} rated, I_{out} rated, approx.	83 %
Power loss at V_{out} rated, I_{out} rated, approx.	12 W
Closed-loop control	
Dynamic mains compensation (V_{in} rated $\pm 15\%$), max.	0.3 %
Dynamic load smoothing (I_{out} : 50/100/50 %), $U_{out} \pm$ typ.	3 %
Load step setting time 50 to 100%, typ.	5 ms
Load step setting time 100 to 50%, typ.	5 ms
Setting time maximum	5 ms
Protection and monitoring	
Output overvoltage protection	< 33 V
Current limitation, typ.	2.65 A
Characteristic feature of the output short-circuit protected	Yes
Short-circuit protection	Constant current characteristic
Enduring short circuit current Effective level typical	2.7 A
Overload/short-circuit indicator	-
Safety	
Primary/secondary isolation	Yes
Potential separation	Safety extra-low output voltage U_{out} acc. to EN 60950-1 and EN 50178
Protection class	Class I
stray current maximum	3.5 mA
CE mark	Yes
UL/CSA approval	Yes
UL/cUL (CSA) approval	cULus-Listed (UL 508, CSA C22.2 No. 107.1), File E197259; cURus-Recognized (UL 60950-1, CSA C22.2 No. 60950-1) File E151273
Explosion protection	ATEX (EX) II 3G Ex nA II T4; cULus (ISA 12.12.01, CSA C22.2 No.213) File E330455
FM approval	Yes
FM approval	Class I, Div. 2, Group ABCD, T4
CB approval	No
Marine approval	GL, ABS, BV, DNV, LRS, NK
Degree of protection (EN 60529)	IP20
EMC	
Emitted interference	EN 55022 Class B
Supply harmonics limitation	not applicable
Noise immunity	EN 61000-6-2

Order No.	6EP1 332-1SH71
Product	S7-1200 PM1207
Power supply, type	24 V/2.5 A
Operating data	
Ambient temperature	
• in operation	0 ... 60 °C
- Note	with natural convection
Ambient temperature	
• on transport	-40 ... +85 °C
Ambient temperature	
• in storage	-40 ... +85 °C
Humidity class according to EN 60721	Climate class 3K3, no condensation
Mechanics	
Connection technology	screw-type terminals
Connections	
• Supply input	L, N, PE: 1 screw terminal each for 0.5 ... 2.5 mm ²
• Output	L+, M: 2 screw terminals each for 0.5 ... 2.5 mm ²
• Auxiliary	-
Width of the housing	70 mm
Height of the housing	100 mm
Depth of the housing	75 mm
Installation width	70 mm
Installation height	140 mm
Weight, approx.	0.3 kg
Product feature of the housing housing for side-by-side mounting	Yes
Type of mounting wall mounting	Yes
Type of fixing cap rail mounting	Yes
Type of mounting S7-300 rail mounting	No
Installation	Snaps onto DIN rail EN 60715 35x7.5/15, wall mounting

Ordering data

SIMATIC S7-1200 PM 1207

Input 120/230 V AC,
output 24 V DC/2.5 A

Order No.

6EP1 332-1SH71

Overview



- Stabilized power supply for SIPLUS S7-1200
- In the S7-1200 design
- Input 120/230 V AC, output 24 V DC, 2.5 A (derating: 1.5 A from 60 °C)

Note:

SIPLUS extreme products are based on Siemens Industry standard products. The contents listed here were taken from the respective standard products. SIPLUS extreme-specific information was added.

3

SIPLUS PM 1207 power supply		
Order number	6AG1 332-1SH71-4AA0	6AG1 332-1SH71-7AA0
Order number based on	6EP1 332-1SH71	6EP1 332-1SH71
Ambient temperature range	0 ... +60 °C	-25 ... +70 °C
Conformal coating	Coating of the printed circuit boards and the electronic components	
Technical data	The technical data of the standard product applies except for the ambient conditions.	
Ambient conditions		
Relative humidity	100%, condensation/frost permissible. No commissioning if condensation present.	
Biologically active substances, compliance with EN 60721-3-3	Class 3B2 mold spores, fungal spores (excluding fauna). The supplied plug covers must remain in place over the unused interfaces during operation!	
Chemically active substances, compliance with EN 60721-3-3	Class 3C4 incl. salt spray in accordance with EN60068-2-52 (degree of severity 3). The supplied plug covers must remain in place over the unused interfaces during operation!	
Mechanically active substances, compliance with EN 60721-3-3	Class 3S4 incl. sand, dust. The supplied plug covers must remain in place over the unused interfaces during operation!	
Air pressure (depending on the highest positive temperature range specified)	1080 ... 795 hPa (-1000 ... +2000 m) see ambient temperature range 795 ... 658 hPa (+2000 ... +3500 m) derating 10 K 658 ... 540 hPa (+3500 ... +5000 m) derating 20 K	

For technical documentation on SIPLUS, see:
<http://www.siemens.com/siplus-extreme>

Ordering data	Order No.
SIPLUS PM 1207 power supply (extended temperature range and medial exposure) Input 120/230 V AC, output 24 V DC, 2.5 A; derating from + 55 °C to + 70 °C to 1.2 A output current Ambient temperature -25 ... +70 °C Ambient temperature 0 ... +60 °C	6AG1 332-1SH71- 7AA0 6AG1 332-1SH71- 4AA0

SIMATIC S7-1200

Operator control and monitoring

Basic Panels – Standard

Overview

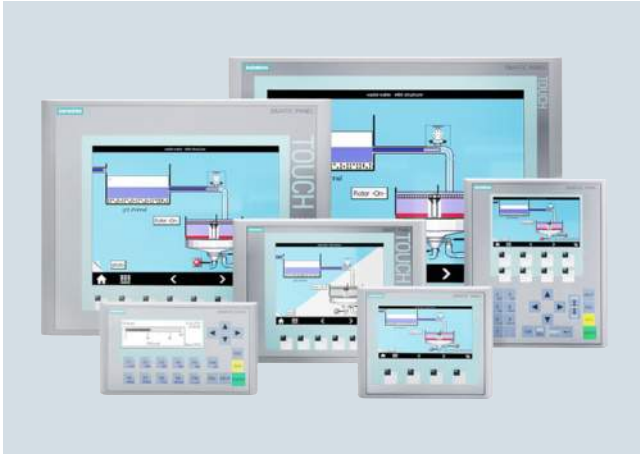

- Ideal entry-level series from 3" to 15" for operating and monitoring compact machines and systems
- Clear process representation thanks to use of pixel-graphics displays
- Intuitive operation using Touch and tactile function keys
- Equipped with all the necessary basic functions such as alarm logging, recipe management, plots, vector graphics, and language switching
- Simple connection to the controller via integral Ethernet interface or separate version with RS485/422

Technical specifications

	6AV6 647-0AH11-3AX0 SIMATIC HMI KP300 Basic mono PN	6AV6 647-0AJ11-3AX0 SIMATIC HMI KP400 Basic color PN	6AV6 647-0AA11-3AX0 SIMATIC HMI KTP400 Basic mono PN	6AV6 647-0AK11-3AX0 SIMATIC HMI KTP400 Basic color PN
Display				
Design of display	FSTN	TFT	STN	TFT
Screen diagonal	3.6 in	4.3 in	3.8 in	4.3 in
Number of colors	4; Backlit display only (white, red, green, yellow)	256	4; Grayscales	256
Resolution (pixels)				
• Horizontal image resolution	240	480	320	480
• Vertical image resolution	80	272	240	272
Backlighting				
• MTBF backlighting (at 25 °C)	50 000 h	50 000 h	30 000 h	50 000 h
• Dimmable backlight	No	No	No	No
Control elements				
Keyboard fonts				
• Number of function keys	10	8	4	4
Touch operation				
• Design as touch screen	No	No	Yes	Yes
Installation type/mounting				
Mounting in portrait format possible	No	No	Yes	Yes
Supply voltage				
Type of supply voltage	DC	DC	DC	DC
Rated voltage/DC	24 V	24 V	24 V	24 V
Memory				
Usable memory for user data	512 kbyte	512 kbyte	512 kbyte	512 kbyte
Type of output				
Acoustics				
• Buzzer	No	No	Yes	Yes

Technical specifications (continued)

	6AV6 647-0AH11-3AX0 SIMATIC HMI KP300 Basic mono PN	6AV6 647-0AJ11-3AX0 SIMATIC HMI KP400 Basic color PN	6AV6 647-0AA11-3AX0 SIMATIC HMI KTP400 Basic mono PN	6AV6 647-0AK11-3AX0 SIMATIC HMI KTP400 Basic color PN
Time of day				
Clock				
• Software clock	Yes	Yes	Yes	Yes
• Battery-backed	No	No	No	No
• Synchronizable	Yes	Yes	Yes	Yes
Interfaces				
Number of RS 485 interfaces	0	0	0	0
Number of USB interfaces	0	0	0	0
Number of SD card slots	0	0	0	0
Industrial Ethernet				
• Number of industrial Ethernet interfaces	1	1	1	1
Protocols				
PROFINET	Yes	Yes	Yes	Yes
PROFIBUS	No	No	No	No
MPI	No	No	No	No
Degree and class of protection				
Type of protection	IP20	IP20	IP20	IP20
IP (at the front)	IP65	IP65	IP65	IP65
Enclosure type 4x at the front	Yes	Yes	Yes	Yes
Standards, approvals, certificates				
CE	Yes	Yes	Yes	Yes
cULus	Yes	Yes	Yes	Yes
GL	Yes	No	Yes	Yes
ABS	Yes	No	Yes	Yes
BV	Yes	No	Yes	Yes
DNV	Yes	No	Yes	Yes
LRS	Yes	No	Yes	Yes
Class NK	Yes	No	Yes	Yes
Use in hazardous areas				
• ATEX Zone 2	No	No	No	No
• ATEX Zone 22	No	No	No	No
• cULus Class I Zone 2, Division 2	Yes	No	No	No
• FM Class I Division 2	No	No	No	No
Ambient conditions				
Operating temperature				
• Operation (vertical installation)				
- in vertical mounting position/ minimum	0 °C	0 °C	0 °C	0 °C
- in vertical mounting position/ maximum	50 °C	50 °C	50 °C	50 °C
Relative humidity				
• max. relative humidity	90 %	90 %	90 %	90 %
Configuration				
Configuration software				
• STEP 7 Basic (TIA Portal)	Yes; via integrated WinCC Basic (TIA Portal)	Yes; via integrated WinCC Basic (TIA Portal)	Yes; via integrated WinCC Basic (TIA Portal)	Yes; via integrated WinCC Basic (TIA Portal)
• WinCC flexible Compact	No	No	Yes	No
• WinCC Basic (TIA Portal)	Yes	Yes	Yes	Yes

SIMATIC S7-1200

Operator control and monitoring

Basic Panels – Standard

Technical specifications (continued)

	6AV6 647-0AH11-3AX0 SIMATIC HMI KP300 Basic mono PN	6AV6 647-0AJ11-3AX0 SIMATIC HMI KP400 Basic color PN	6AV6 647-0AA11-3AX0 SIMATIC HMI KTP400 Basic mono PN	6AV6 647-0AK11-3AX0 SIMATIC HMI KTP400 Basic color PN
Languages				
Online languages				
• Number of online/runtime languages	5	5	5	5
Functionality under WinCC flexible				
Task planner				
• time-controlled	No	No	No	No
• task-controlled	Yes	Yes	Yes	Yes
With alarm logging system (incl. buffer and acknowledgment)				
• Number of bit messages	200	200	200	200
• Number of analog messages	15	15	15	15
• Message buffer				
- Number of entries	256	256	256	256
- Circulating buffer	Yes	Yes	Yes	Yes
- retentive	Yes	Yes	Yes	Yes
Recipes				
• Number of recipes	5	5	5	5
• Size of internal recipe memory	40 kbyte	40 kbyte	40 kbyte	40 kbyte
• Recipe memory expandable	No	No	No	No
Variables				
• Number of variables per device	250	500	250	500
• Number of variables per screen	30	30	30	30
Images				
• Number of configurable images	50	50	50	50
Archiving				
• Number of archives per device	0	0	0	0
Security				
• Number of user groups	50	50	50	50
• Number of users	50	50	50	50
Transfer (upload/download)				
• MPI/PROFIBUS DP	No	No	No	No
• Ethernet	Yes	Yes	Yes	Yes
Process coupling				
• S7-1200	Yes	Yes	Yes	Yes
• S7-1500	Yes	Yes	Yes	Yes
• S7-200	Yes	Yes	Yes	Yes
• S7-300/400	Yes	Yes	Yes	Yes
• LOGO!	Yes	Yes	Yes	Yes
• Win AC	Yes	No	Yes	No
• SIMOTION	No	No	No	No
• Allen Bradley (EtherNet/IP)	Yes	Yes	Yes	Yes
• Allen Bradley (DF1)	No	No	No	No
• Mitsubishi (MC TCP/IP)	Yes	Yes	Yes	Yes
• Mitsubishi (FX)	No	No	No	No
• OMRON (FINS TCP)	No	No	No	No
• OMRON (LINK/Multiink)	No	No	No	No
• Modicon (Modbus TCP/IP)	Yes	Yes	Yes	Yes
• Modicon (Modbus)	No	No	No	No

Technical specifications (continued)

	6AV6 647-0AH11-3AX0 SIMATIC HMI KP300 Basic mono PN	6AV6 647-0AJ11-3AX0 SIMATIC HMI KP400 Basic color PN	6AV6 647-0AA11-3AX0 SIMATIC HMI KTP400 Basic mono PN	6AV6 647-0AK11-3AX0 SIMATIC HMI KTP400 Basic color PN
I/O				
I/O devices				
• Printer	No	No	No	No
• Multi Media Card	No	No	No	No
• SD card	No	No	No	No
• USB memory	No	No	No	No
Mechanics/material				
Type of housing (front)				
• Plastic	Yes	Yes	Yes	Yes
Dimensions				
Width of the housing front	165 mm	162 mm	140 mm	140 mm
Height of housing front	97 mm	189 mm	116 mm	116 mm
Mounting cutout, width	149 mm	135 mm	123 mm	123 mm
Mounting cutout, height	82 mm	171 mm	99 mm	99 mm
Weight				
Weight without packaging	0.25 kg	0.51 kg	0.32 kg	0.34 kg

	6AV6 647-0AB11-3AX0 SIMATIC HMI KTP600 Basic mono PN	6AV6 647-0AC11-3AX0 SIMATIC HMI KTP600 Basic color DP	6AV6 647-0AD11-3AX0 SIMATIC HMI KTP600 Basic color PN
Display			
Design of display	STN	TFT	TFT
Screen diagonal	5.7 in	5.7 in	5.7 in
Number of colors	4; Grayscale	256	256
Resolution (pixels)			
• Horizontal image resolution	320	320	320
• Vertical image resolution	240	240	240
Backlighting			
• MTBF backlighting (at 25 °C)	50 000 h	50 000 h	50 000 h
• Dimmable backlight	No	No	No
Control elements			
Keyboard fonts			
• Number of function keys	6	6	6
Touch operation			
• Design as touch screen	Yes	Yes	Yes
Installation type/mounting			
Mounting in portrait format possible	Yes	Yes	Yes
Supply voltage			
Type of supply voltage	DC	DC	DC
Rated voltage/DC	24 V	24 V	24 V
Memory			
Usable memory for user data	512 kbyte	512 kbyte	512 kbyte
Type of output			
Acoustics			
• Buzzer	Yes	Yes	Yes

SIMATIC S7-1200

Operator control and monitoring

Basic Panels – Standard

Technical specifications (continued)

	6AV6 647-0AB11-3AX0 SIMATIC HMI KTP600 Basic mono PN	6AV6 647-0AC11-3AX0 SIMATIC HMI KTP600 Basic color DP	6AV6 647-0AD11-3AX0 SIMATIC HMI KTP600 Basic color PN
Time of day			
Clock			
• Software clock	Yes	Yes	Yes
• Battery-backed	No	No	No
• Synchronizable	Yes	Yes	Yes
Interfaces			
Number of RS 485 interfaces	0	1	0
Number of USB interfaces	0	0	0
Number of SD card slots	0	0	0
Industrial Ethernet			
• Number of industrial Ethernet interfaces	1	0	1
Protocols			
PROFINET	Yes	No	Yes
PROFIBUS	No	Yes	No
MPI	No	Yes	No
Degree and class of protection			
Type of protection	IP20	IP20	IP20
IP (at the front)	IP65	IP65	IP65
Enclosure type 4x at the front	Yes	Yes	Yes
Standards, approvals, certificates			
CE	Yes	Yes	Yes
cULus	Yes	Yes	Yes
GL	Yes	Yes	Yes
ABS	Yes	Yes	Yes
BV	Yes	Yes	Yes
DNV	Yes	Yes	Yes
LRS	Yes	Yes	Yes
Class NK	Yes	Yes	Yes
Use in hazardous areas			
• ATEX Zone 2	No	No	No
• ATEX Zone 22	No	No	No
• cULus Class I Zone 2, Division 2	No	No	No
• FM Class I Division 2	No	No	No
Ambient conditions			
Operating temperature			
• Operation (vertical installation)			
- in vertical mounting position/ minimum	0 °C	0 °C	0 °C
- in vertical mounting position/ maximum	50 °C	50 °C	50 °C
Relative humidity			
• max. relative humidity	90 %	90 %	90 %
Configuration			
Configuration software			
• STEP 7 Basic (TIA Portal)	Yes; via integrated WinCC Basic (TIA Portal)	Yes; via integrated WinCC Basic (TIA Portal)	Yes; via integrated WinCC Basic (TIA Portal)
• WinCC flexible Compact	Yes	Yes	Yes
• WinCC Basic (TIA Portal)	Yes	Yes	Yes

Technical specifications (continued)

	6AV6 647-0AB11-3AX0 SIMATIC HMI KTP600 Basic mono PN	6AV6 647-0AC11-3AX0 SIMATIC HMI KTP600 Basic color DP	6AV6 647-0AD11-3AX0 SIMATIC HMI KTP600 Basic color PN
Languages			
Online languages			
• Number of online/runtime languages	5	5	5
Functionality under WinCC flexible			
Task planner			
• time-controlled	No	No	No
• task-controlled	Yes	Yes	Yes
With alarm logging system (incl. buffer and acknowledgment)			
• Number of bit messages	200	200	200
• Number of analog messages	15	15	15
• Message buffer			
- Number of entries	256	256	256
- Circulating buffer	Yes	Yes	Yes
- retentive	Yes	Yes	Yes
Recipes			
• Number of recipes	5	5	5
• Size of internal recipe memory	40 kbyte	40 kbyte	40 kbyte
• Recipe memory expandable	No	No	No
Variables			
• Number of variables per device	500	500	500
• Number of variables per screen	30	30	30
Images			
• Number of configurable images	50	50	50
Archiving			
• Number of archives per device	0	0	0
Security			
• Number of user groups	50	50	50
• Number of users	50	50	50
Transfer (upload/download)			
• MPI/PROFIBUS DP	No	Yes	No
• Ethernet	Yes	No	Yes
Process coupling			
• S7-1200	Yes	Yes	Yes
• S7-1500	Yes	Yes	Yes
• S7-200	Yes	Yes	Yes
• S7-300/400	Yes	Yes	Yes
• LOGO!	Yes	Yes	Yes
• Win AC	Yes	Yes	Yes
• SIMOTION	No	No	No
• Allen Bradley (EtherNet/IP)	Yes	No	Yes
• Allen Bradley (DF1)	No	Yes	No
• Mitsubishi (MC TCP/IP)	Yes	No	Yes
• Mitsubishi (FX)	No	Yes	No
• OMRON (FINS TCP)	No	No	No
• OMRON (LINK/Multilink)	No	Yes	No
• Modicon (Modbus TCP/IP)	Yes	No	Yes
• Modicon (Modbus)	No	Yes	No

SIMATIC S7-1200

Operator control and monitoring

Basic Panels – Standard

Technical specifications (continued)

	6AV6 647-0AB11-3AX0 SIMATIC HMI KTP600 Basic mono PN	6AV6 647-0AC11-3AX0 SIMATIC HMI KTP600 Basic color DP	6AV6 647-0AD11-3AX0 SIMATIC HMI KTP600 Basic color PN
I/O			
I/O devices			
• Printer	No	No	No
• Multi Media Card	No	No	No
• SD card	No	No	No
• USB memory	No	No	No
Mechanics/material			
Type of housing (front)			
• Plastic	Yes	Yes	Yes
Dimensions			
Width of the housing front	214 mm	214 mm	214 mm
Height of housing front	158 mm	158 mm	158 mm
Mounting cutout, width	197 mm	197 mm	197 mm
Mounting cutout, height	141 mm	141 mm	141 mm
Weight			
Weight without packaging	1.07 kg	1.07 kg	1.07 kg

	6AV6 647-0AE11-3AX0 SIMATIC HMI KTP1000 Basic color DP	6AV6 647-0AF11-3AX0 SIMATIC HMI KTP1000 Basic color PN	6AV6 647-0AG11-3AX0 SIMATIC HMI TP1500 Basic color PN
Display			
Design of display	TFT	TFT	TFT
Screen diagonal	10.4 in	10.4 in	15 in
Number of colors	256	256	256
Resolution (pixels)			
• Horizontal image resolution	640	640	1 024
• Vertical image resolution	480	480	768
Backlighting			
• MTBF backlighting (at 25 °C)	50 000 h	50 000 h	50 000 h
• Dimmable backlight	No	No	No
Control elements			
Keyboard fonts			
• Number of function keys	8	8	0
Touch operation			
• Design as touch screen	Yes	Yes	Yes
Installation type/mounting			
Mounting in portrait format possible	No	No	No
Supply voltage			
Type of supply voltage	DC	DC	DC
Rated voltage/DC	24 V	24 V	24 V
Memory			
Usable memory for user data	1 024 kbyte	1 024 kbyte	1 024 kbyte
Type of output			
Acoustics			
• Buzzer	Yes	Yes	Yes

Technical specifications (continued)

	6AV6 647-0AE11-3AX0 SIMATIC HMI KTP1000 Basic color DP	6AV6 647-0AF11-3AX0 SIMATIC HMI KTP1000 Basic color PN	6AV6 647-0AG11-3AX0 SIMATIC HMI TP1500 Basic color PN
Time of day			
Clock			
• Software clock	Yes	Yes	Yes
• Battery-backed	No	No	No
• Synchronizable	Yes	Yes	Yes
Interfaces			
Number of RS 485 interfaces	1	0	0
Number of USB interfaces	0	0	0
Number of SD card slots	0	0	0
Industrial Ethernet			
• Number of industrial Ethernet interfaces	0	1	1
Protocols			
PROFINET	No	Yes	Yes
PROFIBUS	Yes	No	No
MPI	Yes	No	No
Degree and class of protection			
Type of protection	IP20	IP20	IP20
IP (at the front)	IP65	IP65	IP65
Enclosure type 4x at the front	Yes	Yes	Yes
Standards, approvals, certificates			
CE	Yes	Yes	Yes
cULus	Yes	Yes	Yes
GL	Yes	Yes	No
ABS	Yes	Yes	No
BV	Yes	Yes	No
DNV	Yes	Yes	No
LRS	Yes	Yes	No
Class NK	Yes	Yes	No
Use in hazardous areas			
• ATEX Zone 2	No	No	No
• ATEX Zone 22	No	No	No
• cULus Class I Zone 2, Division 2	No	No	No
• FM Class I Division 2	No	No	No
Ambient conditions			
Operating temperature			
• Operation (vertical installation)			
- in vertical mounting position/ minimum	0 °C	0 °C	0 °C
- in vertical mounting position/ maximum	50 °C	50 °C	50 °C
Relative humidity			
• max. relative humidity	90 %	90 %	90 %
Configuration			
Configuration software			
• STEP 7 Basic (TIA Portal)	Yes; via integrated WinCC Basic (TIA Portal)	Yes; via integrated WinCC Basic (TIA Portal)	Yes; via integrated WinCC Basic (TIA Portal)
• WinCC flexible Compact	Yes	Yes	Yes
• WinCC Basic (TIA Portal)	Yes	Yes	Yes

SIMATIC S7-1200

Operator control and monitoring

Basic Panels – Standard

Technical specifications (continued)

	6AV6 647-0AE11-3AX0 SIMATIC HMI KTP1000 Basic color DP	6AV6 647-0AF11-3AX0 SIMATIC HMI KTP1000 Basic color PN	6AV6 647-0AG11-3AX0 SIMATIC HMI TP1500 Basic color PN
Languages			
Online languages			
• Number of online/runtime languages	5	5	5
Functionality under WinCC flexible			
Task planner			
• time-controlled	No	No	No
• task-controlled	Yes	Yes	Yes
With alarm logging system (incl. buffer and acknowledgment)			
• Number of bit messages	200	200	200
• Number of analog messages	15	15	15
• Message buffer			
- Number of entries	256	256	256
- Circulating buffer	Yes	Yes	Yes
- retentive	Yes	Yes	Yes
Recipes			
• Number of recipes	5	5	5
• Size of internal recipe memory	40 kbyte	40 kbyte	40 kbyte
• Recipe memory expandable	No	No	No
Variables			
• Number of variables per device	500	500	500
• Number of variables per screen	30	30	30
Images			
• Number of configurable images	50	50	50
Archiving			
• Number of archives per device	0	0	0
Security			
• Number of user groups	50	50	50
• Number of users	50	50	50
Transfer (upload/download)			
• MPI/PROFIBUS DP	Yes	No	No
• Ethernet	No	Yes	Yes
Process coupling			
• S7-1200	Yes	Yes	Yes
• S7-1500	Yes	Yes	Yes
• S7-200	Yes	Yes	Yes
• S7-300/400	Yes	Yes	Yes
• LOGO!	Yes	Yes	Yes
• Win AC	Yes	Yes	Yes
• SIMOTION	No	No	No
• Allen Bradley (EtherNet/IP)	No	Yes	Yes
• Allen Bradley (DF1)	Yes	No	No
• Mitsubishi (MC TCP/IP)	No	Yes	Yes
• Mitsubishi (FX)	Yes	No	No
• OMRON (FINS TCP)	No	No	No
• OMRON (LINK/Multilink)	Yes	No	No
• Modicon (Modbus TCP/IP)	No	Yes	Yes
• Modicon (Modbus)	Yes	Yes	Yes
I/O			
I/O devices			
• Printer	No	No	No
• Multi Media Card	No	No	No
• SD card	No	No	No
• USB memory	No	No	No
Mechanics/material			
Type of housing (front)			
• Plastic	Yes	Yes	Yes

Technical specifications (continued)

	6AV6 647-0AE11-3AX0 SIMATIC HMI KTP1000 Basic color DP	6AV6 647-0AF11-3AX0 SIMATIC HMI KTP1000 Basic color PN	6AV6 647-0AG11-3AX0 SIMATIC HMI TP1500 Basic color PN
Dimensions			
Width of the housing front	335 mm	335 mm	400 mm
Height of housing front	275 mm	275 mm	310 mm
Mounting cutout, width	310 mm	310 mm	367 mm
Mounting cutout, height	248 mm	248 mm	289 mm
Weight			
Weight without packaging	2.65 kg	2.65 kg	4.2 kg

Ordering data

Ordering data	Order No.	Order No.
SIMATIC HMI Basic Panels, Key and Touch		
SIMATIC HMI KTP400 Basic mono PN	6AV6 647-0AA11-3AX0	Starter kits consist of: <ul style="list-style-type: none"> the respective SIMATIC HMI Basic Panel <ul style="list-style-type: none"> SIMATIC HMI KP300 Basic mono PN SIMATIC HMI KTP400 Basic mono PN SIMATIC HMI KTP600 Basic color PN SIMATIC S7-1200 CPU 1212C AC/DC/Rly SIMATIC S7-1200 Simulator Module SIM 1274 SIMATIC STEP 7 BASIC CD SIMATIC S7-1200 HMI Manual Collection CD Ethernet CAT5 cable, 2 m
SIMATIC HMI KTP400 Basic color PN	6AV6 647-0AK11-3AX0	
SIMATIC HMI KTP600 Basic mono PN	6AV6 647-0AB11-3AX0	
SIMATIC HMI KTP600 Basic color DP	6AV6 647-0AC11-3AX0	
SIMATIC HMI KTP600 Basic color PN	6AV6 647-0AD11-3AX0	
SIMATIC HMI KTP1000 Basic color DP	6AV6 647-0AE11-3AX0	
SIMATIC HMI KTP1000 Basic color PN	6AV6 647-0AF11-3AX0	
SIMATIC HMI Basic Panels, Key		
SIMATIC HMI KP300 Basic mono PN	6AV6 647-0AH11-3AX0	See Catalog ST 80/ST PC, HMI software
SIMATIC HMI KP400 Basic color PN	6AV6 647-0AJ11-3AX0	
SIMATIC HMI Basic Panels, Touch		
SIMATIC HMI TP1500 Basic color PN	6AV6 647-0AG11-3AX0	See Catalog ST 80/ST PC, HMI software
Starter kit SIMATIC S7-1200 + KP300 Basic mono PN	6AV6 651-7HA01-3AA3	
Starter kit SIMATIC S7-1200 + KTP400 Basic color PN	6AV6 651-7KA01-3AA3	
Starter kit SIMATIC S7-1200 + KTP600 Basic color PN	6AV6 651-7DA01-3AA3	
		Configuration All device versions: SIMATIC WinCC Basic/Comfort/Professional or SIMATIC STEP 7 Basic (with integrated WinCC Basic) 6"-15": SIMATIC WinCC flexible Compact
		Documentation (to be ordered separately) You can find the manual for the Basic Panels on the Internet at: http://support.automation.siemens.com
		SIMATIC HMI Manual Collection 6AV6 691-1SA01-0AX0
		Electronic documentation, on DVD 5 languages (English, French, German, Italian and Spanish); contains: all currently available user manuals, manuals and communication manuals for SIMATIC HMI
		Accessories See Catalog ST 80/ST PC, HMI accessories

SIMATIC S7-1200

SIPLUS operator control and monitoring

SIPLUS Basic Panels

Overview



- Ideal entry-level series of 3.8 inches to 15 inches for operating and monitoring compact machines and systems
- Clear process representation through the use of full-graphic displays
- Intuitive operation via touch and tactile function keys
- Equipped with all the necessary basic functions such as reporting, recipe management, curve representation, vector graphics, and language selection
- Easy connection to the controller via integrated Ethernet interface or a separate version with RS485/422

Note:

SIPLUS extreme products are based on Siemens Industry standard products. The contents listed here were taken from the respective standard products. SIPLUS extreme specific information was added.

	SIPLUS HMI KTP 300 BASIC MONO PN	SIPLUS HMI KTP 400 BASIC MONO PN	SIPLUS HMI KTP 600 BASIC COLOR PN	SIPLUS HMI KTP 1000 BASIC COLOR DP	SIPLUS HMI KTP 1000 BASIC COLOR PN	SIPLUS HMI TP 1500 BASIC COLOR PN
Order number	6AG1647-0AH11-2AX0	6AG1647-0AA11-2AX0	6AG1647-0AD11-2AX0	6AG1647-0AE11-4AX0	6AG1647-0AF11-4AX0	6AG1647-0AG11-4AX0
Order No. based on	6AV6647-0AH11-3AX0	6AV6647-0AA11-3AX0	6AV6647-0AD11-3AX0	6AV6647-0AE11-3AX0	6AV6647-0AF11-3AX0	6AV6647-0AG11-3AX0
Ambient temperature range	-25 ... +60 °C	-10 ... +60 °C	-25 ... +60 °C	0 ... +50 °C	0 ... +50 °C	0 ... +50 °C
Conformal coating	Coating of the printed circuit boards and the electronic components					
Technical data	The technical data of the standard product applies except for the ambient conditions.					
Ambient conditions						
Relative humidity	100 %, condensation/frost permissible. No commissioning if condensation present.					
Biologically active substances, compliance with EN 60721-3-3	Class 3B2 mold and fungal spores (excluding fauna). The supplied plug covers must remain in place over the unused interfaces during operation!					
Chemically active substances, compliance with EN 60721-3-3	Class 3C4 incl. salt spray in accordance with EN60068-2-52 (degree of severity 3). The supplied plug covers must remain in place over the unused interfaces during operation!					
Mechanically active substances, compliance with EN 60721-3-3	Class 3S4 incl. sand, dust. The supplied plug covers must remain in place over the unused interfaces during operation!					
Air pressure (depending on the highest positive temperature range specified)	1 080 ... 795 hPa (-1 000 ... +2 000 m) see ambient temperature range		795 ... 658 hPa (+2000 ... +3500 m) derating 10 K	658 ... 540 hPa (+3 500 ... +5 000 m) derating 20 K		

For technical documentation on SIPLUS, see:
<http://www.siemens.com/siplus-extreme>

SIMATIC S7-1200

SIPLUS operator control and monitoring

SIPLUS Basic Panels

Ordering data	Order No.		Order No.
SIPLUS HMI KTP300 Basic mono PN For areas with extreme medial exposure (conformal coating); ambient temperature -25 ... +60 °C	6AG1 647-0AH11-2AX0	SIPLUS HMI KTP 1000 Basic Color DP For areas with extreme medial exposure (conformal coating); ambient temperature 0 ... +50 °C	6AG1 647-0AE11-4AX0
SIPLUS HMI KTP400 Basic mono PN For areas with extreme medial exposure (conformal coating); ambient temperature -10 ... +60 °C	6AG1 647-0AA11-2AX0	SIPLUS HMI KTP 1000 Basic Color PN For areas with extreme medial exposure (conformal coating); ambient temperature 0 ... +50 °C	6AG1 647-0AF11-4AX0
SIPLUS HMI KTP 600 Basic color PN For areas with extreme medial exposure (conformal coating); ambient temperature -25 ... +60 °C	6AG1 647-0AD11-2AX0	SIPLUS HMI TP 1500 Basic Color PN For areas with extreme medial exposure (conformal coating); ambient temperature 0 ... +50 °C	6AG1 647-0AG11-4AX0
		Accessories	See SIMATIC Basic Panels, page 3/133

Overview

- Software for the SIMATIC S7-1200
- Functions for all phases of the automation project:
 - configuring and parameterizing the hardware
 - specifying the communication
 - programming in LAD (Ladder Diagram) and FBD (Function Block Diagram)
 - configuration of the visualization
 - test, commissioning, and service

The following is available:

- STEP 7 Basic

For further information, see chapter 11.

SIMATIC S7-1500



4/2 4/2	Introduction S7-1500
4/4 4/4 4/4 4/4 4/4	Central processing units Standard CPUs CPU 1511-1 PN CPU 1513-1 PN CPU 1516-3 PN/DP
4/10 4/10 4/13	Digital modules SM 521 digital input modules SM 522 digital output modules
4/17 4/17 4/18	SIPLUS digital modules SIPLUS SM 521 digital input modules SIPLUS SM 522 digital output modules
4/19 4/19 4/23	Analog modules SM 531 analog input modules SM 532 analog output modules
4/26 4/26 4/27	SIPLUS analog modules SIPLUS SM 531 analog input modules SIPLUS SM 532 analog output modules
4/28 4/28	Technology modules TM Count 2x24V counter modules
4/31 4/31 4/34 4/36	Communication CM PtP CM 1542-5 CP 1543-1
4/39 4/39 4/40	Connection system Front connectors SIMATIC TOP connect system cabling for SIMATIC S7-1500 and ET 200MP
4/48 4/48 4/50	Power supplies System power supplies Load power supplies
4/52 4/52	SIPLUS power supplies SIPLUS system power supplies
4/53 4/53 4/53 4/54	Accessories Mounting rails Labeling sheets Spare parts

Brochures

For brochures serving as selection guides for SIMATIC products refer to:

www.siemens.com/simatic/printmaterial

SIMATIC S7-1500

Introduction

S7-1500

Overview



- Modular, scalable, and universally usable system in IP20 level of protection
- The system solution for a variety of automation applications in discrete automation
- Highest performance with excellent usability
- Configurable exclusively in the Totally Integrated Automation Portal with STEP 7 Professional V12

Performance

- Performance increase through
 - Faster command execution
 - Language extensions
 - New data types
 - Faster backplane bus
 - Optimized code generation
- Powerful communication:
 - PROFINET IO (2-port switch) as standard interface
 - Optional additional PROFINET interface, e.g. for network separation
 - Expandable with communication modules for bus systems and point-to-point connection

Integrated technology

- Motion Control integrated without additional modules:
 - Standardized blocks (PLCopen) for connection of analog and PROFIdrive-capable drives
 - The Motion Control functionality supports speed-controlled and positioning axes as well as external encoders
- Comprehensive trace functions for all CPU variables for real-time diagnosis and sporadic error detection; for effective commissioning and quick optimization of drives and controls
- Comprehensive control functionalities: e.g. easily configurable blocks for automatic optimization of the control parameters for optimum control quality
- Additional functions through available technology modules: e.g. high-speed counting, position detection, or measurement functions for signals up to 1 MHz

Security Integrated

- Password-based know-how protection against unauthorized reading and modification of program blocks
- Copy protection for greater protection against unauthorized copying of program blocks: With copy protection, individual blocks on the SIMATIC memory card can be tied to its serial number so that the block can only be run if the configured memory card is inserted into the CPU.
- Rights concept with four different authorization levels: Different access rights can be assigned to various user groups. The new protection level 4 makes it possible to also restrict communication to HMI devices.
- Improved manipulation protection: Changed or unauthorized transfers of engineering data are detected by the controller.
- For use of an Ethernet CP (CP 1543-1):
 - Additional access protection by means of a firewall
 - Setup of secure VPN connections (V12 SP1 or higher)

Design and handling

- CPUs with display for plain text information:
 - Information about order numbers, firmware version, and the serial number of all connected modules can be displayed
 - Setting the IP address of the CPU and additional network settings directly on site, without programming device
 - Display of occurring error messages directly as plain text message, meaning reduction in downtime
- Uniform front connectors for all modules and integrated potential bridges for flexible potential group formation simplify stock keeping and reduce wiring costs
- Integrated DIN rail in the S7-1500 mounting rail: quick and easy installation of additional components such as miniature circuit breakers, relays, etc.
- Central expansion with signal modules: for flexible adaptation to any application
- System cabling for digital signal modules: for fast and clearly arranged connecting to sensors and actuators in the field and simple wiring inside the control cabinet
- Power supply:
 - Load current supply modules (power modules) to supply the module with 24 V
 - Power supply modules to supply power to the internal module electronics via the backplane bus
- Distributed expansion:
 - Use of up to 30 signal modules, communication modules, and technology modules via the PROFINET interface module IM 155-5 for the ET 200MP I/O system
 - No difference in terms of handling and system functions in central and distributed operation

Integrated system diagnostics

- Integrated system diagnostics for CPUs, activated by default:
 - Consistent plain text display of system diagnostic information in the display, TIA Portal, HMI, and web server, even for drive messages. Messages are updated even if the CPU is in STOP state.
 - System diagnostics integrated in the CPU firmware. Configuration by user not required. The diagnostics is automatically updated on configuration changes.

Overview (continued)

Datalog (archives) and recipes

- SIMATIC memory card:
 - Plug-in load memory
 - Permits firmware updates
 - Storage option for STEP 7 projects (including comments and symbols), additional documentation, or csv files (for recipes and archives)
 - Easy access to plant-relevant operating data and configuration data with Office tools via the SD Card reader (two-way data exchange from and to the controller)
- Integrated web server:
 - Easy access to plant-relevant operating data and configuration data via a Web browser

Approvals

At the start of delivery, the SIMATIC S7-1500 complies with national and international standards:

- CE
- cULus
- C-TICK
- CFMus
- ATEX
- EN 61000-6-4
- EN 60068-2-1/ -2/ -6/ -14/ -27/ -30/ -32
- EN 61131-2

For brochures serving as selection guides for SIMATIC products refer to:

www.siemens.com/simatic/printmaterial

Technical specifications

General technical specifications

Degree of protection	IP20 acc. to IEC 60 529
Ambient temperature	
• Horizontal installation	0...60 °C (display: at an operating temperature of typ. 50 °C, the display is switched off.)
• Vertical installation	0... 40 °C (display: at an operating temperature of typ. 40 °C, the display is switched off.)
Relative humidity	5%...95%, no condensation
Atmospheric pressure	From 1080 to 795 hPa (corresponds to an altitude of -1000 to +2000 m)
Insulation	
• < 50 V	707 V DC test voltage (type test)
• < 150 V	2200 V DC test voltage
• < 250 V	2500 V DC test voltage
Electromagnetic compatibility	Requirements of the EMC directive; interference immunity according to IEC 61000-6-2
• Pulse-shaped disturbance variables	Test according to: Electrostatic discharge according to IEC 61000-4-2, burst pulses according to IEC 61000-4-4, energy single pulse (surge) according to IEC 61000-4-5,
• Sinusoidal disturbance variables	Test according to: HF irradiation according to IEC 61000-4-3, HF decoupling according to IEC 61000-4-6
• Emission of radio frequency interference	Requirements of the EMC directive; interference emission according to EN 61000-6-4 Interference emission according to 61000-6-4 Interference emission of electromagnetic fields according to EN 61000-6-4
Mechanical stress	
• Vibrations	Testing according to EN 60068-2-6 Tested with: 5 Hz ≤ f ≤ 8.4 Hz, constant amplitude 7 mm; 9 Hz ≤ f ≤ 150 Hz, constant acceleration 2 g; duration of vibration: 10 frequency passes per axis in each direction of the 3 mutually perpendicular axes
• Shock	Testing according to EN 60068-2-27 Tested with: Half-wave: strength of shock 15 g peak value, 11 ms duration; shock direction: 3 shocks each in ± direction in each of the 3 mutually vertical axes

SIMATIC S7-1500

Central processing units

Standard CPUs

Overview CPU 1511-1 PN



- Entry-level CPU in the S7-1500 controller product range
- Suitable for applications with medium requirements for program scope and processing speed
- Used as central controller in production lines with central and distributed I/O
- PROFINET IO IRT interface with 2-port switch
- PROFINET IO Controller for operating distributed I/O on PROFINET
- PROFINET I-Device for connecting the CPU as an intelligent PROFINET device under a SIMATIC or non-Siemens PROFINET I/O controller
- Isochronous mode
- SIMATIC memory card required for operation of the CPU

Overview CPU 1513-1 PN



- The CPU for applications with medium/high requirements for program/data storage in the S7-1500 controller product range
- High processing speed for binary and floating-point arithmetic
- Used as central controller in production lines with central and distributed I/O
- PROFINET IO IRT interface with 2-port switch

- PROFINET IO Controller for operating distributed I/O on PROFINET
- PROFINET I-Device for connecting the CPU as an intelligent PROFINET device under a SIMATIC or non-Siemens PROFINET I/O controller
- Isochronous mode
- SIMATIC memory card required for operation of the CPU

Overview CPU 1516-3 PN/DP



- The CPU with large program and data memory in the S7-1500 controller product range for applications with high program scope requirements.
- High processing speed for binary and floating-point arithmetic
- Used as central controller in production lines with central and distributed I/O
- PROFINET IO IRT interface with 2-port switch
- Additional PROFINET interface with separate IP address
- PROFINET IO controller for operating distributed I/O on PROFINET.
- PROFINET I-Device for connecting the CPU as an intelligent PROFINET device under a SIMATIC or non-Siemens PROFINET IO controller.
- PROFIBUS DP master interface
- Isochronous mode on PROFIBUS and PROFINET
- SIMATIC memory card required for operation of the CPU

Technical specifications

	6ES7 511-1AK00-0AB0 CPU 1511-1 PN	6ES7 513-1AL00-0AB0 CPU 1513-1 PN	6ES7 516-3AN00-0AB0 CPU 1516-3 PN/DP
General information			
Engineering with • STEP 7 TIA Portal can be configured/ integrated as of version	V12.0	V12.0	V12.0
Display			
Screen diagonal (cm)	3.45 cm	3.45 cm	6.1 cm
Supply voltage			
Type of supply voltage	24 V DC	24 V DC	24 V DC
Power losses			
Power loss, typ.	5.7 W	5.7 W	7 W
Memory			
Work memory • integrated (for program) • integrated (for data)	150 kbyte 1 Mbyte	300 kbyte 1.5 Mbyte	1 Mbyte 5 Mbyte
Load memory • Plug-in (SIMATIC Memory Card), max.	2 Gbyte	2 Gbyte	2 Gbyte
CPU processing times			
for bit operations, typ.	60 ns	40 ns	10 ns
for word operations, typ.	72 ns	48 ns	12 ns
for fixed point arithmetic, typ.	96 ns	64 ns	16 ns
for floating point arithmetic, typ.	384 ns	256 ns	64 ns
Counters, timers and their retentivity			
S7 counter • Number	2 048	2 048	2 048
IEC counter • Number	Any (only limited by the main memory)	Any (only limited by the main memory)	Any (only limited by the main memory)
S7 times • Number	2 048	2 048	2 048
IEC timer • Number	Any (only limited by the main memory)	Any (only limited by the main memory)	Any (only limited by the main memory)
Data areas and their retentivity			
Flag • Number, max.	16 kbyte	16 kbyte	16 kbyte
Address area			
I/O address area • Inputs	32 kbyte; All inputs are in the process image	32 kbyte; All inputs are in the process image	32 kbyte; All inputs are in the process image
• Outputs	32 kbyte; All outputs are in the process image	32 kbyte; All outputs are in the process image	32 kbyte; All outputs are in the process image
Time of day			
Clock • Type	Hardware clock	Hardware clock	Hardware clock

SIMATIC S7-1500

Central processing units

Standard CPUs

Technical specifications (continued)

	6ES7 511-1AK00-0AB0 CPU 1511-1 PN	6ES7 513-1AL00-0AB0 CPU 1513-1 PN	6ES7 516-3AN00-0AB0 CPU 1516-3 PN/DP
Interfaces			
1st interface			
• Interface types			
- Number of ports	2	2	2
- Integrated switch	Yes	Yes	Yes
- RJ 45 (Ethernet)	Yes	Yes	Yes
• Protocols			
- PROFINET IO Controller	Yes	Yes	Yes
- PROFINET IO Device	Yes	Yes	Yes
- SIMATIC communication	Yes	Yes	Yes
- Open IE communication	Yes	Yes	Yes
- Web server	Yes	Yes	Yes
- Media redundancy	Yes	Yes	Yes
2nd interface			
• Interface types			
- Number of ports			1
- Integrated switch			No
- RJ 45 (Ethernet)			Yes
• Protocols			
- PROFINET IO Controller			No
- PROFINET IO Device			No
- SIMATIC communication			Yes
- Open IE communication			Yes
- Web server			Yes
3rd interface			
• Interface types			
- Number of ports			1
- RS 485			Yes
• Protocols			
- SIMATIC communication			Yes
- PROFIBUS DP master			Yes
- PROFIBUS DP slave			No
Interface types			
Number of connections			
• Number of connections, max.	96	128	256
Protocols			
PROFINET IO Controller			
• Services			
- Max. number of connectable IO devices for RT	128	128	256
- Number of IO Devices with IRT and the option "high performance", max.	64	64	64
PROFIBUS			
• Services			
- Number of DP slaves			125; In total, up to 768 distributed I/O devices can be connected via CPs/CMs via PROFIBUS or PROFINET.
Isochronous mode			
Isochronous operation (application synchronized up to terminal)	Yes	Yes	Yes

Technical specifications (continued)

	6ES7 511-1AK00-0AB0 CPU 1511-1 PN	6ES7 513-1AL00-0AB0 CPU 1513-1 PN	6ES7 516-3AN00-0AB0 CPU 1516-3 PN/DP
Supported technology objects			
Motion	Yes	Yes	Yes
• Speed-controlled axis - Number of speed-controlled axes, max.	6; Up to 6 axes in total (speed-controlled, positioning axis, external encoders) are supported	6; Up to 6 axes in total (speed-controlled, positioning axis, external encoders) are supported	20; Up to 20 axes in total (speed-controlled, positioning axis, external encoders) are supported
• Positioning axis - Number of positioning axes, max.	6; Up to 6 axes in total (speed-controlled, positioning axis, external encoders) are supported	6; Up to 6 axes in total (speed-controlled, positioning axis, external encoders) are supported	20; Up to 20 axes in total (speed-controlled, positioning axis, external encoders) are supported
• External encoders - Number of external encoders, max.	6; Up to 6 axes in total (speed-controlled, positioning axis, external encoders) are supported	6; Up to 6 axes in total (speed-controlled, positioning axis, external encoders) are supported	20; Up to 20 axes in total (speed-controlled, positioning axis, external encoders) are supported
Controller			
• PID_Compact	Yes; Universal PID controller with integrated optimization	Yes; Universal PID controller with integrated optimization	Yes; Universal PID controller with integrated optimization
• PID_3Step	Yes; PID controller with integrated optimization for valves	Yes; PID controller with integrated optimization for valves	Yes; PID controller with integrated optimization for valves
Counting and measuring			
• High-speed counter	Yes	Yes	Yes
Ambient conditions			
Operating temperature			
• horizontal installation, min.	0 °C	0 °C	0 °C
• horizontal installation, max.	60 °C; Display: 50 °C, at an operating temperature of typically 50 °C, the display is switched off	60 °C; Display: 50 °C, at an operating temperature of typically 50 °C, the display is switched off	60 °C; Display: 50 °C, at an operating temperature of typically 50 °C, the display is switched off
• vertical installation, min.	0 °C	0 °C	0 °C
• vertical installation, max.	40 °C	40 °C	40 °C
Configuration			
Programming			
• Programming language			
- LAD	Yes	Yes	Yes
- FBD	Yes	Yes	Yes
- STL	Yes	Yes	Yes
- SCL	Yes	Yes	Yes
Know-how protection			
• User program protection	Yes	Yes	Yes
• Copy protection	Yes	Yes	Yes
• Block protection	Yes	Yes	Yes
Access protection			
• Password for display	Yes	Yes	Yes
• Protection level: Write protection	Yes	Yes	Yes
• Protection level: Read/write protection	Yes	Yes	Yes
• Protection level: Complete protection	Yes	Yes	Yes
Dimensions			
Width	35 mm	35 mm	70 mm
Height	147 mm	147 mm	147 mm
Depth	129 mm	129 mm	129 mm
Weight			
Weight, approx.	430 g	430 g	845 g

SIMATIC S7-1500

Central processing units

Standard CPUs

4

Ordering data	Order No.	Order No.
CPU 1511-1 PN Work memory 150 KB for program, 1 MB for data, PROFINET IO IRT interface, SIMATIC memory card required	6ES7 511-1AK00-0AB0	
CPU 1513-1 PN Work memory 300 KB for program, 1.5 MB for data, PROFINET IO IRT interface, SIMATIC memory card required	6ES7 513-1AL00-0AB0	
CPU 1516-3 PN 1 MB RAM for program, 5 MB for data, PROFINET IO IRT interface, PROFINET/PROFIBUS interface; SIMATIC memory card required	6ES7 516-3AN00-0AB0	
Accessories		
SIMATIC memory card		
4 MB	6ES7 954-8LC01-0AA0	
12 MB	6ES7 954-8LE01-0AA0	
24 MB	6ES7 954-8LF01-0AA0	
2 GB	6ES7 954-8LP01-0AA0	
SIMATIC S7-1500 mounting rail		
Fixed lengths, with grounding elements		
<ul style="list-style-type: none"> • 160 mm • 482 mm • 530 mm • 830 mm 	6ES7 590-1AB60-0AA0 6ES7 590-1AE80-0AA0 6ES7 590-1AF30-0AA0 6ES7 590-1AJ30-0AA0	
For cutting to length by customer, without drill holes; grounding elements must be ordered separately		
<ul style="list-style-type: none"> • 2000 mm 	6ES7 590-1BC00-0AA0	
PE connection element for mounting rail 2000 mm		
20 units	6ES7 590-5AA00-0AA0	
Power supply		
For supplying the backplane bus of the S7-1500		
24 V DC input voltage, power 25 W	6ES7 505-0KA00-0AB0	
24/48/60 V DC input voltage, power 60 W	6ES7 505-0RA00-0AB0	
120/230 V AC input voltage, power 60 W	6ES7 507-0RA00-0AB0	
Power connector		
With coding element for power supply module; spare part, 10 units	6ES7 590-8AA00-0AA0	
Load power supply		
24 V DC/3A	6EP1 332-4BA00	
24 V DC/8A	6EP1 333-4BA00	
Power supply connector		
Spare part; for connecting the 24 V DC supply voltage		
<ul style="list-style-type: none"> • with push-in terminals 	6ES7 193-4JB00-0AA0	
PROFIBUS FastConnect bus connector RS485 with 90° cable outlet		
with insulation displacement, max. transmission rate 12 Mbit/s		
without PG interface, grounding via control cabinet contact surface; 1 unit		6ES7 972-0BA70-0XA0
with PG interface, grounding via control cabinet contact surface; 1 unit		6ES7 972-0BB70-0XA0
PROFIBUS FC Standard Cable GP		
Standard type with special design for fast mounting, 2-core, shielded; sold by the meter; max. delivery unit 1000 m, minimum order quantity 20 m		6XV1 830-0EH10
PROFIBUS FC Robust Cable		
2-wire, shielded; sold by the meter; max. delivery unit 1000 m, minimum order quantity 20 m		6XV1 830-0JH10
PROFIBUS FC Flexible Cable		
2-wire, shielded; sold by the meter; max. delivery unit 1000 m, minimum order quantity 20 m		6XV1 831-2K
PROFIBUS FC Trailing Cable		
2-wire, shielded; sold by the meter; max. delivery unit 1000 m, minimum order quantity 20 m		
Sheath color: Petrol		6XV1 830-3EH10
Sheath color: Violet		6XV1 831-2L
PROFIBUS FC Food Cable		
2-wire, shielded; sold by the meter; max. delivery unit 1000 m, minimum order quantity 20 m		6XV1 830-0GH10
PROFIBUS FC Ground Cable		
2-wire, shielded; sold by the meter; max. delivery unit 1000 m, minimum order quantity 20 m		6XV1 830-3FH10
PROFIBUS FC FRNC Cable GP		
2-wire, shielded, flame-retardant, with copolymer outer sheath FRNC; sold by the meter; max. delivery unit 1000 m, minimum order quantity 20 m		6XV1 830-0LH10
PROFIBUS FastConnect Stripping Tool		
Preadjusted stripping tool for fast stripping of PROFIBUS FastConnect bus cables		6GK1 905-6AA00

SIMATIC S7-1500

Central processing units

Standard CPUs

Ordering data	Order No.	Order No.
IE FC RJ45 plugs RJ45 plug connector for Industrial Ethernet with a rugged metal enclosure and integrated insulation displacement contacts for connecting Industrial Ethernet FC installation cables		Display for CPU 1511-1 PN and CPU 1513-1 PN; spare part
IE FC RJ45 Plug 180 180° cable outlet 1 unit 10 units 50 units	6GK1 901-1BB10-2AA0 6GK1 901-1BB10-2AB0 6GK1 901-1BB10-2AE0	Display for CPU 1516-3 PN/DP; spare part
IE FC TP Standard Cable GP 2x2 4-core, shielded TP installation cable for connection to IE FC Outlet RJ45/ IE FC RJ45 Plug; PROFINET-compliant; with UL approval; sold by the meter; max. delivery unit 1000 m, minimum order quantity 20 m	6XV1 840-2AH10	SIMATIC S7-1500 Starter Kit 6ES7 511-1AK00-4YB5 Comprising: CPU 1511-1 PN, SIMATIC memory card 4 MB, digital input DI 16 x 24 V DC HF, digital output DO 16 x 24 V DC/0.5 A ST, 160 mm mounting rail, front connector, STEP 7 Professional V12, 365-day license, power supply 60 W AC 120/230 V, Standard Ethernet CAT 5 cable (2 m), screwdriver, documentation
IE FC TP Trailing Cable 2 x 2 (Type C) 4-core, shielded TP installation cable for connection to IE FC Outlet RJ45/ IE FC RJ45 Plug 180/90 for use as trailing cable; PROFINET-compatible; with UL approval; sold by the meter; max. delivery unit 1000 m, minimum order quantity 20 m	6XV1 840-3AH10	SIMATIC STEP 7 V12 Target system: SIMATIC S7-1200, S7-1500, S7-300, S7-400, WinAC, SIMATIC Basic Panels Requirement: Microsoft Windows XP Professional SP3 (32-bit) Microsoft Windows 7 Professional SP1 (32/64-bit) Microsoft Windows 7 Enterprise SP1 (32/64-bit) Microsoft Windows 7 Ultimate SP1 (32/64-bit) Microsoft Server 2003 R2 Std. SP2 (32-bit) Microsoft Server 2008 Std. SP2 (32/64-bit) Type of delivery: German, English, Chinese, Italian, French, Spanish
IE FC TP Marine Cable 2 x 2 (Type B) 4-core, shielded TP installation cable for connection to IE FC Outlet RJ45/ IE FC RJ45 Plug 180/90 with marine approval, sold by the meter; max. delivery unit 1000 m, minimum order quantity 20 m	6XV1 840-4AH10	STEP 7 Professional V12, Floating License 6ES7 822-1AA02-0YA5
IE FC Stripping Tool Preadjusted stripping tool for fast stripping of Industrial Ethernet FC cables	6GK1 901-1GA00	

SIMATIC S7-1500

Digital modules

SM 521 digital input modules

Overview



- 16 and 32-channel digital input modules
- For flexible adaptation of the controller to the corresponding task
- For subsequent expansion of the system with additional inputs

4

Technical specifications

	6ES7 521-1BH00-0AB0 DI 16x24 V DC HF	6ES7 521-1BL00-0AB0 DI 32x24 V DC HF	6ES7 521-1BH50-0AA0 DI 16x24 V DC SRC BA	6ES7 521-1FH00-0AA0 DI 16x230 V AC BA
General information				
Product function				
• I&M data	Yes; IM0 to IM3	Yes; IM0 to IM3	Yes; IM0 to IM3	Yes; IM0 to IM3
Engineering with				
• STEP 7 TIA Portal can be configured/integrated as of version	V12.0 / V12.0	V12.0 / V12.0	V12.0 / V12.0	V12.0 / V12.0
• STEP 7 can be configured/integrated as of version	as of V5.5 SP3 / -	as of V5.5 SP3 / -	as of V5.5 SP3 / -	as of V5.5 SP3 / -
Supply voltage				
Type of supply voltage	DC	DC		
Rated voltage/DC	24 V	24 V		
Reverse polarity protection	Yes	Yes		
Digital inputs				
Number/binary inputs	16	32	16	16
m/p-reading	p-reading	p-reading	m-reading	
Input characteristic curve acc. to IEC 61131, Type 1				Yes
Input characteristic curve acc. to IEC 61131, Type 3	Yes	Yes	Yes	
Input voltage				
• Type of input voltage	DC	DC	DC	AC
• Rated value, AC				230 V; 120/230 V AC; 60/50 Hz
• Rated value, DC	24 V	24 V	24 V	
• for signal "0"	-30 to +5 V	-30 to +5 V	30 to -5 V	0 to 40 V AC
• for signal "1"	11 to 30 V	11 to 30 V	-11 to -30 V	79 to 264 V AC
Input current				
• for signal "1", typ.	2.5 mA	2.5 mA	4.5 mA	11 mA; At 230 V AC and 5.5 mA at 120 V AC
Input delay (for rated value of input voltage)				
• for standard inputs				
- Parameterizable	Yes; 0.05 / 0.1 / 0.4 / 1.6 / 3.2 / 12.8 / 20 ms	Yes; 0.05 / 0.1 / 0.4 / 1.6 / 3.2 / 12.8 / 20 ms	No	No
• for interrupt inputs				
- Parameterizable	Yes	Yes	No	No
Cable length				
• Cable length, shielded, max.	1 000 m	1 000 m	1 000 m	1 000 m
• Cable length unshielded, max.	600 m	600 m	600 m	600 m

Technical specifications (continued)

	6ES7 521-1BH00-0AB0 DI 16x24 V DC HF	6ES7 521-1BL00-0AB0 DI 32x24 V DC HF	6ES7 521-1BH50-0AA0 DI 16x24 V DC SRC BA	6ES7 521-1FH00-0AA0 DI 16x230 V AC BA
Encoder				
Connectable encoders				
• 2-wire sensor	Yes	Yes	Yes	Yes
- Permissible quiescent current (2-wire sensor), max.	1.5 mA	1.5 mA	1.5 mA	2 mA
Isochronous mode				
Isochronous operation (application synchronized up to terminal)	Yes	Yes	No	No
Filtering and processing time (TCI), min.	80 µs; At 50 µs filter time	80 µs; At 50 µs filter time		
Bus cycle time (TDP), min.	250 µs	250 µs		
Interrupts/diagnostics/ status information				
Alarms				
• Diagnostic alarm	Yes	Yes	No	No
• Hardware interrupt	Yes	Yes	No	No
Diagnostic messages				
• Diagnostics	Yes	Yes	No	No
• Monitoring the supply voltage	Yes	Yes	No	No
• Wire break	Yes; to I < 350 µA	Yes; to I < 350 µA	No	No
• Short circuit	No	No	No	No
• Fuse blown	No	No	No	No
Diagnostics indication LED				
• RUN LED	Yes; Green LED	Yes; Green LED	Yes; Green LED	Yes; Green LED
• ERROR LED	Yes; Red LED	Yes; Red LED	Yes; Red LED	Yes; Red LED
• Monitoring the supply voltage	Yes; Green LED	Yes; Green LED	No	No
• Channel status display	Yes; Green LED	Yes; Green LED	Yes; Green LED	Yes; Green LED
• for channel diagnostics	Yes; Red LED	Yes; Red LED	No	No
• for module diagnostics	Yes; Red LED	Yes; Red LED	No	Yes; Red LED
Galvanic isolation				
Electrical isolation channels				
• between the channels and the backplane bus	Yes	Yes	Yes	Yes
Isolation				
Isolation checked with	707 V DC (type test)	707 V DC (type test)	707 V DC (type test)	2500 V DC
Decentralized operation				
Supports fast startup	Yes; 500 ms	Yes; 500 ms	Yes; 500 ms	Yes; 500 ms
Dimensions				
Width	35 mm	35 mm	35 mm	35 mm
Height	147 mm	147 mm	147 mm	147 mm
Depth	129 mm	129 mm	129 mm	129 mm
Weight				
Weight, approx.	240 g	260 g	230 g	300 g

SIMATIC S7-1500

Digital modules

SM 521 digital input modules

Ordering data

Order No.

Order No.

SM 521 digital input modules

16 inputs, 24 V DC, isolated, parameterizable diagnostics and hardware interrupts

6ES7 521-1BH00-0AB0

32 inputs, 24 V DC, isolated, parameterizable diagnostics and hardware interrupts

6ES7 521-1BL00-0AB0

16 inputs, 24 V DC, isolated, input delay 3.2 ms

6ES7 521-1BH50-0AA0

16 inputs, 230 V AC, isolated, input delay 20 ms

6ES7 521-1FH00-0AA0

Accessories**Front connectors**

Including four potential bridges, cable ties, and individual labeling strips; 40-pole screw-type terminal

6ES7 592-1AM00-0XB0

Potential bridges for front connectors

20 units; spare part

6ES7 592-3AA00-0AA0

DIN A4 labeling sheets

10 sheets with 10 labeling strips each for I/O modules; perforated, Al grey

6ES7 592-2AX00-0AA0

U connector

5 units; spare part

6ES7 590-0AA00-0AA0

Universal front door for I/O modules

5 front doors; with 5 labeling strips (front) and 5 cabling diagrams per front door; spare part

6ES7 528-0AA00-7AA0

Overview



- 8, 16 and 32-channel digital output modules
- For flexible adaptation of the controller to the corresponding task
- For subsequent expansion of the system with additional outputs

Technical specifications

	6ES7 522-1BH00-0AB0	6ES7 522-1BL00-0AB0	6ES7 522-1BF00-0AB0	6ES7 522-5HF00-0AB0	6ES7 522-5FF00-0AB0
General information					
Product function • I&M data	Yes; IM0 to IM3	Yes; IM0 to IM3	Yes; IM0 to IM3	Yes; IM0 to IM3	Yes; IM0 to IM3
Engineering with • STEP 7 TIA Portal can be configured/integrated as of version • STEP 7 can be configured/integrated as of version	V12.0 / V12.0 as of V5.5 SP3 / -	V12.0 / V12.0 as of V5.5 SP3 / -	V12.0 / V12.0 as of V5.5 SP3 / -	V12.0 / V12.0 as of V5.5 SP3 / -	V12.0 / V12.0 as of V5.5 SP3 / -
Supply voltage					
Type of supply voltage	DC	DC	DC	DC	
Rated voltage/DC	24 V	24 V	24 V	24 V	
Reverse polarity protection	Yes; through internal protection with 7 A per group	Yes; through internal protection with 7 A per group	Yes; through internal protection with 10 A per group	Yes	
Digital outputs					
Type of digital output	Transistor	Transistor	Transistor	Relays	Triac
Number/binary outputs	16	32	8	8	8
Digital outputs, configurable	Yes	Yes	Yes	Yes	Yes
Functionality/short-circuit strength	Yes; Clocked electronically	Yes; Clocked electronically	Yes; Clocked electronically	No	No
Limitation of inductive shutdown voltage to	L+ (-53 V)	L+ (-53 V)	-17 V		
Low energy/fluorescent lamps with electronic control gear				10 X 58 W (25,000 operating cycles)	
Fluorescent tubes, conventionally compensated				1 X 58 W (25,000 operating cycles)	
Fluorescent tubes, uncompensated				10 X 58 W (25,000 operating cycles)	
Controlling a digital input	Yes	Yes	Yes	possible	
Switching capacity of the outputs • with resistive load, max. • on lamp load, max.	0.5 A 5 W	0.5 A 5 W	2 A 10 W	1 500 W; (10,000 operating cycles)	2 A 50 W
Load resistance range • lower limit • upper limit	48 Ω 12 kΩ	48 Ω 12 kΩ	12 Ω 4 kΩ		
Output voltage • Type of output voltage • for signal "1", min.	DC L+ (-0.8 V)	DC L+ (-0.8 V)	DC L+ (-0.8 V)		AC L1 (-1.5 V) at maximum output current; L1 (-8.5 V) at minimum output current

SIMATIC S7-1500

Digital modules

SM 522 digital output modules

Technical specifications (continued)

	6ES7 522-1BH00-0AB0	6ES7 522-1BL00-0AB0	6ES7 522-1BF00-0AB0	6ES7 522-5HF00-0AB0	6ES7 522-5FF00-0AB0
Output current					
• for signal "1" rated value	0.5 A	0.5 A	2 A	5 A	2 A
• for signal "0" residual current, max.	0.5 mA	0.5 mA	0.5 mA	0 A	2 mA
Output delay with resistive load					
• "0" to "1", max.	100 µs	100 µs	100 µs		1 AC cycle
• "1" to "0", max.	500 µs	500 µs	500 µs		1 AC cycle
Parallel switching of 2 outputs					
• for logic links	Yes	Yes	Yes	Yes	No
• for increased power	No	No	No	No	No
• for redundant control of a load	Yes	Yes	Yes	Yes	Yes
Switching frequency					
• with resistive load, max.	100 Hz	100 Hz	100 Hz	2 Hz	10 Hz
• with inductive load, max.	0.5 Hz; to IEC 947-5-1, DC13	0.5 Hz; to IEC 947-5-1, DC13	0.5 Hz; to IEC 947-5-1, DC13	0.5 Hz	0.5 Hz
• on lamp load, max.	10 Hz	10 Hz	10 Hz	2 Hz	1 Hz
Aggregate current of the outputs					
• Max. current per channel	0.5 A; (see additional description in the manual)	0.5 A; (see additional description in the manual)	2 A; (see additional description in the manual)	8 A; (see additional description in the manual)	2 A; (see additional description in the manual)
• Max. current per group	4 A; (see additional description in the manual)	4 A; (see additional description in the manual)	8 A; (see additional description in the manual)	8 A; (see additional description in the manual)	2 A; (see additional description in the manual)
• Max. current per module	8 A; (see additional description in the manual)	16 A; (see additional description in the manual)	16 A; (see additional description in the manual)	64 A; (see additional description in the manual)	10 A; (see additional description in the manual)
Relay outputs					
• Number of relay outputs				8	
• Rated input voltage of relay coil L+ (DC)				24 V	
• Current consumption of relays (coil current of all relays), max.				80 mA	
• external protection for relay outputs				With miniature circuit breaker with characteristic B for: cos φ 1.0: 600 A cos φ 0.5 ... 0.7: 900 A with 8 A Diazed fuse: 1000 A	
• Contact connection (internal)				No	
• Size of motor starters according to NEMA, max.				5	5
• Number of operating cycles, max.				4 000 000; (see additional description in the manual)	
• Relay approved acc. to UL 508				Yes; 250 V AC/5 A g.p.; 120 V AC TV-4 tungsten; A300, R300	
• Switching capacity of contacts				(see additional description in the manual)	
- with inductive load, max.				(see additional description in the manual)	
- Switching frequency/contacts/at ohmic load/maximum				(see additional description in the manual)	
Cable length					
• Cable length, shielded, max.	1 000 m	1 000 m	1 000 m	1 000 m	1 000 m
• Cable length unshielded, max.	600 m	600 m	600 m	600 m	600 m
Isochronous mode					
Isochronous operation (application synchronized up to terminal)	Yes	Yes	No	No	No
Execution and activation time (TCO), min.	70 µs	70 µs			
Bus cycle time (TDP), min.	250 µs	250 µs			

Technical specifications (continued)

	6ES7 522-1BH00-0AB0	6ES7 522-1BL00-0AB0	6ES7 522-1BF00-0AB0	6ES7 522-5HF00-0AB0	6ES7 522-5FF00-0AB0
Interrupts/diagnostics/ status information					
Substitute values connectable	Yes	Yes	Yes	Yes	Yes
Alarms					
• Diagnostic alarm	Yes	Yes	Yes	Yes	No
Diagnostic messages					
• Diagnostics	Yes	Yes	Yes	Yes	No
• Monitoring the supply voltage	Yes	Yes	Yes	Yes	No
• Wire break	No	No	No	No	No
• Short circuit	Yes	Yes	Yes	No	No
• Fuse blown	No	No	No	No	No
Diagnostics indication LED					
• RUN LED	Yes; Green LED	Yes; Green LED	Yes; Green LED	Yes; Green LED	Yes; Green LED
• ERROR LED	Yes; Red LED	Yes; Red LED	Yes; Red LED	Yes; Red LED	Yes; Red LED
• Monitoring the supply voltage	Yes; Green LED	Yes; Green LED	Yes; Green LED	Yes; Green LED	No
• Channel status display	Yes; Green LED	Yes; Green LED	Yes; Green LED	Yes; Green LED	Yes; Green LED
• for channel diagnostics	No	No	Yes; Red LED	No	No
• for module diagnostics	Yes; Red LED	Yes; Red LED	Yes; Red LED	Yes; Red LED	Yes; Red LED
Galvanic isolation					
Electrical isolation channels					
• between the channels and the backplane bus	Yes	Yes	Yes	Yes	Yes
Isolation					
Isolation checked with	707 V DC (type test)	707 V DC (type test)	707 V DC (type test)	Between the channels: 2500 V DC; between the channels and backplane bus: 2500 V DC; between L+ backplane bus 707 V DC (type test)	2500 V DC
Decentralized operation					
Supports fast startup	Yes; 500 ms	Yes; 500 ms	Yes; 500 ms	Yes; 500 ms	Yes; 500 ms
Dimensions					
Width	35 mm	35 mm	35 mm	35 mm	35 mm
Height	147 mm	147 mm	147 mm	147 mm	147 mm
Depth	129 mm	129 mm	129 mm	129 mm	129 mm
Weight					
Weight, approx.	230 g	280 g	240 g	350 g	290 g

SIMATIC S7-1500

Digital modules

SM 522 digital output modules

Ordering data

SM 522 digital output modules

8 outputs, 24 V DC;
2 A, isolated

6ES7 522-1BF00-0AB0

16 outputs, 24 V DC;
0.5 A, isolated

6ES7 522-1BH00-0AB0

32 outputs, 24 V DC;
0.5 A, isolated

6ES7 522-1BL00-0AB0

8 relay outputs,
230 V AC, 5 A

6ES7 522-5HF00-0AB0

8 outputs (triac),
230 V AC, 2 A

6ES7 522-5FF00-0AB0

Accessories

Front connectors

Including four potential bridges,
cable ties, and individual labeling
strips; 40-pole screw-type terminal

6ES7 592-1AM00-0XB0

Potential bridges for front connectors

20 units; spare part

6ES7 592-3AA00-0AA0

DIN A4 labeling sheets

10 sheets with 10 labeling strips
each for I/O modules; perforated,
Al grey

6ES7 592-2AX00-0AA0

U connector

5 units; spare part

6ES7 590-0AA00-0AA0

Universal front door for I/O modules

5 front doors; with 5 labeling strips
(front) and 5 cabling diagrams per
front door; spare part

6ES7 528-0AA00-7AA0

Overview



- 16 and 32-channel digital input modules
- For flexible adaptation of the controller to the corresponding task
- For subsequent expansion of the system with additional inputs

Note:

SIPLUS extreme products are based on Siemens Industry standard products. The contents listed here were taken from the respective standard products. SIPLUS extreme-specific information was added.

Technical specifications

The technical data correspond to those of the based-on modules apart from the values listed in the table:

based on	6AG1 521-1BH00-7AB0 6ES7 521-1BH00-0AB0	6AG1 521-1BL00-7AB0 6ES7 521-1BL00-0AB0
Ambient conditions		
Operating temperature		
• Horizontal mounting position	-40...+70 °C	-40...+70 °C
• Vertical mounting position	-40...+50 °C	-40...+50 °C
Extended ambient conditions		
• with reference to ambient temperature, air pressure and altitude	Tmin ... Tmax at 1080 hPa ... 795 hPa (-1000 m ... +2000 m) // Tmin ... (Tmax - 10K) at 795 hPa ... 658 hPa (+2000 m ... +3500 m) // Tmin ... (Tmax - 20K) at 658 hPa ... 540 hPa (+3500 m ... +5000 m)	Tmin ... Tmax at 1080 hPa ... 795 hPa (-1000 m ... +2000 m) // Tmin ... (Tmax - 10K) at 795 hPa ... 658 hPa (+2000 m ... +3500 m) // Tmin ... (Tmax - 20K) at 658 hPa ... 540 hPa (+3500 m ... +5000 m)
Relative humidity		
• with condensation / maximum / tested in accordance with IEC 60068-2-38	100%; RH incl. condensation/frost (no commissioning in bedewed state)	100%; RH incl. condensation/frost (no commissioning in bedewed state)
Resistance		
• to biologically active substances / compliance with EN 60721-3-3	Yes; Class 3B2 mold and fungal spores (except fauna); the supplied plug covers must remain in place on the unused interfaces during operation.	Yes; Class 3B2 mold and fungal spores (except fauna); the supplied plug covers must remain in place on the unused interfaces during operation.
• to chemically active substances / compliance with EN 60721-3-3	Yes; Class 3C4 (RH < 75%) incl. salt spray in accordance with EN 60068-2-52 (severity 3); the supplied plug covers must remain in place on the unused interfaces during operation.	Yes; Class 3C4 (RH < 75%) incl. salt spray in accordance with EN 60068-2-52 (severity 3); the supplied plug covers must remain in place on the unused interfaces during operation.
• to mechanically active substances / compliance with EN 60721-3-3	Yes; Class 3S4 incl. sand, dust; the supplied plug covers must remain in place on unused interfaces during operation.	Yes; Class 3S4 incl. sand, dust; the supplied plug covers must remain in place on unused interfaces during operation.

Ordering data

Order No.

SIPLUS SM 521 digital input modules

(extended temperature range and medial exposure)

16 inputs, 24 V DC, isolated, parameterizable diagnostics and hardware interrupts

6AG1 521-1BH00-7AB0

32 inputs, 24 V DC, isolated, parameterizable diagnostics and hardware interrupts

6AG1 521-1BL00-7AB0

Accessories

See SIMATIC S7-1500 SM 521 digital input modules, page 4/12

SIMATIC S7-1500

SIPLUS digital modules

SIPLUS SM 522 digital output modules

Overview



- 16 and 32-channel digital output modules
- For flexible adaptation of the controller to the corresponding task
- For subsequent expansion of the system with additional outputs

Note:

SIPLUS extreme products are based on Siemens Industry standard products. The contents listed here were taken from the respective standard products. SIPLUS extreme-specific information was added.

Technical specifications

The technical data correspond to those of the based-on modules apart from the values listed in the table:

based on	6AG1 522-1BH00-7AB0 6ES7 522-1BH00-0AB0	6AG1 522-1BL00-7AB0 6ES7 522-1BL00-0AB0
Ambient conditions		
Operating temperature		
• Horizontal mounting position	-40...+70 °C	-40...+70 °C
• Vertical mounting position	-40...+50 °C	-40...+50 °C
Extended ambient conditions		
• with reference to ambient temperature, air pressure and altitude	Tmin ... Tmax at 1080 hPa ... 795 hPa (-1000 m ... +2000 m) // Tmin ... (Tmax - 10K) at 795 hPa ... 658 hPa (+2000 m ... +3500 m) // Tmin ... (Tmax - 20K) at 658 hPa ... 540 hPa (+3500 m ... +5000 m)	Tmin ... Tmax at 1080 hPa ... 795 hPa (-1000 m ... +2000 m) // Tmin ... (Tmax - 10K) at 795 hPa ... 658 hPa (+2000 m ... +3500 m) // Tmin ... (Tmax - 20K) at 658 hPa ... 540 hPa (+3500 m ... +5000 m)
Relative humidity		
• with condensation / maximum / tested in accordance with IEC 60068-2-38	100%; RH incl. condensation/frost (no commissioning in bedewed state)	100%; RH incl. condensation/frost (no commissioning in bedewed state)
Resistance		
• to biologically active substances / compliance with EN 60721-3-3	Yes; Class 3B2 mold and fungal spores (except fauna); the supplied plug covers must remain in place on the unused interfaces during operation.	Yes; Class 3B2 mold and fungal spores (except fauna); the supplied plug covers must remain in place on the unused interfaces during operation.
• to chemically active substances / compliance with EN 60721-3-3	Yes; Class 3C4 (RH < 75%) incl. salt spray in accordance with EN 60068-2-52 (severity 3); the supplied plug covers must remain in place on the unused interfaces during operation.	Yes; Class 3C4 (RH < 75%) incl. salt spray in accordance with EN 60068-2-52 (severity 3); the supplied plug covers must remain in place on the unused interfaces during operation.
• to mechanically active substances / compliance with EN 60721-3-3	Yes; Class 3S4 incl. sand, dust; the supplied plug covers must remain in place on unused interfaces during operation.	Yes; Class 3S4 incl. sand, dust; the supplied plug covers must remain in place on unused interfaces during operation.

Ordering data

Order No.

SIPLUS SM 522 digital output modules

(extended temperature range and medial exposure)

16 outputs, 24 V DC; 0.5 A, isolated

6AG1 522-1BH00-7AB0

32 outputs, 24 V DC; 0.5 A, isolated

6AG1 522-1BL00-7AB0

Accessories

See SIMATIC S7-1500 SM 522 digital output modules, page 4/16

Overview



- 8-channel analog input modules
- Optionally with extremely short conversion times
- For the connection of analog sensors without additional amplifiers
- Even solves more complex automation tasks

Technical specifications

	6ES7 531-7KF00-0AB0 AI 8xU/I/RTD/TC ST	6ES7 531-7NF10-0AB0 AI 8xU/I HS
General information		
Product function		
• I&M data	Yes; IM0 to IM3	Yes; IM0 to IM3
Engineering with		
• STEP 7 TIA Portal can be configured/ integrated as of version	V12.0 / V12.0	V12.0 / V12.0
• STEP 7 can be configured/ integrated as of version	as of V5.5 SP3 / -	as of V5.5 SP3 / -
CiR - Configuration in RUN		
Reparameterization possible in RUN	Yes	Yes
Calibration possible in RUN	Yes	Yes
Supply voltage		
Type of supply voltage	DC	DC
Rated voltage/DC	24 V	24 V
Reverse polarity protection	Yes	Yes
Analog inputs		
Number of analog inputs	8	8
Number of analog inputs with current measurement	8	8
Number of analog inputs for voltage measurement	8	8
Number of analog inputs for resistance/resistance thermometer measurement	4	
Number of analog inputs with thermocouple measurement	8	
permissible input voltage for voltage input (destruction limit), max.	28.8 V	28.8 V
Technical unit for temperature measurement adjustable	Yes	
Input ranges (rated values), voltages		
• 1 to 5 V	Yes	Yes
• -1 V to +1 V	Yes	
• -10 V to +10 V	Yes	Yes
• -2.5 V to +2.5 V	Yes	
• -250 mV to +250 mV	Yes	
• -5 V to +5 V	Yes	Yes
• -50 mV to +50 mV	Yes	
• -500 mV to +500 mV	Yes	
• -80 mV to +80 mV	Yes	
Input ranges (rated values), currents		
• 0 to 20 mA	Yes	Yes
• -20 to +20 mA	Yes	Yes
• 4 to 20 mA	Yes	Yes

SIMATIC S7-1500

Analog modules

SM 531 analog input modules

Technical specifications (continued)

	6ES7 531-7KF00-0AB0 AI 8xU/I/RTD/TC ST	6ES7 531-7NF10-0AB0 AI 8xU/I HS
Input ranges (rated values), thermoelements		
• Type B	Yes	
• Type E	Yes	
• Type J	Yes	
• Type K	Yes	
• Type N	Yes	
• Type R	Yes	
• Type S	Yes	
• Type T	Yes	
Input ranges (rated values), resistance thermometers		
• Ni 100	Yes; Standard/climate	
• Ni 1000	Yes; Standard/climate	
• LG-Ni 1000	Yes; Standard/climate	
• Pt 100	Yes; Standard/climate	
• Pt 1000	Yes; Standard/climate	
• Pt 200	Yes; Standard/climate	
• Pt 500	Yes; Standard / climate	
Input ranges (rated values), resistors		
• 0 to 150 ohms	Yes	
• 0 to 300 ohms	Yes	
• 0 to 600 ohms	Yes	
• 0 to 6000 ohms	Yes	
• PTC	Yes	
Thermocouple (TC)		
• Technical unit for temperature measurement	°C/°F/K	
• Temperature compensation - Parameterizable	Yes	
Resistance thermometer (RTD)		
• Technical unit for temperature measurement	°C/°F/K	
Cable length		
• Cable length, shielded, max.	800 m; for U/I, 200 m for R/RTD, 50 m for TC	800 m
Analog value creation		
Integrations and conversion time/ resolution per channel		
• Resolution with overrange (bit including sign), max.	16 bit	16 bit
• Integration time, parameterizable	Yes	
• Integration time, ms	2.5 / 16.67 / 20 / 100	
• Basic conversion time, including integration time, ms	9 / 23 / 27 / 107 ms	
- additional conversion time for wire break monitoring	9 ms	
- additional conversion time for resistance measurement	150 ohm, 300 ohm, 600 ohm, Pt100, Pt200, Ni100: 2 ms 6000 ohm, Pt500, Pt1000, Ni1000, LG-Ni1000, PTC: 4 ms	
• Interference voltage suppression for interference frequency f1 in Hz	400 / 60 / 50 / 10	
• Basic execution time of the module (all channels released)		62.5 µs
Smoothing of measured values		
• Parameterizable	Yes	Yes
Encoder		
Connection of signal encoders		
• for voltage measurement	Yes	Yes
• for current measurement as 2-wire transducer	Yes	Yes
• Burden of 2-wire transmitter, max.	820 Ω	820 Ω
• for current measurement as 4-wire transducer	Yes	Yes
• for resistance measurement with 2-conductor connection	Yes; Only for PTC	
• for resistance measurement with 3-conductor connection	Yes; All measuring ranges except PTC; internal compensation of the cable resistance;	
• for resistance measurement with 4-conductor connection	Yes; All measuring ranges except PTC	

Technical specifications (continued)

	6ES7 531-7KF00-0AB0 AI 8xU/I/RTD/TC ST	6ES7 531-7NF10-0AB0 AI 8xU/I HS
Errors/accuracies		
Basic error limit (operational limit at 25 °C)		
<ul style="list-style-type: none"> Resistance-type thermometer, relative to input area Thermocouple, relative to input area 	Pt xxx standard: +/- 0.7 K Pt xxx climate: +/- 0.2 K Ni xxx standard: +/- 0.3 K Ni xxx climate: +/- 0.15 K Type B: >600 °C +/- 1.7 K type E: >-200 °C +/- 0.7 K type J: >-210 °C +/- 0.8 K type K: >-200 °C +/- 1.2 K type N: >-200 °C +/- 1.2 K type R: >0 °C +/- 1.9 K type S: >0 °C +/- 1.9 K type T: >-200 °C +/- 0.8 K	
Interference voltage suppression for $f = n \times (f_1 \pm 1\%)$, f_1 = interference frequency		
<ul style="list-style-type: none"> Series mode interference (peak value of interference < rated value of input range), min. Common mode voltage, max. Common mode interference, min. 	40 dB 10 V 60 dB	10 V 60 dB; (At 400 Hz: 50 dB)
Isochronous mode		
Isochronous operation (application synchronized up to terminal)		Yes
Filtering and processing time (TCI), min.		100 µs
Bus cycle time (TDP), min.		250 µs
Interrupts/diagnostics/status information		
Alarms		
<ul style="list-style-type: none"> Diagnostic alarm Limit value alarm 	Yes Yes; Two upper and two lower limit values in each case	Yes Yes; Two upper and two lower limit values in each case
Diagnostic messages		
<ul style="list-style-type: none"> Diagnostics Monitoring the supply voltage Wire break Overflow/underflow 	Yes Yes Yes; Only for 1 to 5 V, 4 to 20 mA, TC, R, and RTD Yes	Yes Yes Yes; Only for 1 ... 5V and 4 ... 20mA Yes
Diagnostics indication LED		
<ul style="list-style-type: none"> RUN LED ERROR LED Monitoring the supply voltage Channel status display for channel diagnostics for module diagnostics 	Yes; Green LED Yes; Red LED Yes; Green LED Yes; Green LED Yes; Red LED Yes; Red LED	Yes; Green LED Yes; Red LED Yes; Green LED Yes; Green LED Yes; Red LED Yes; Red LED
Galvanic isolation		
Electrical isolation channels		
<ul style="list-style-type: none"> between the channels and the backplane bus 	Yes	Yes
Isolation		
Isolation checked with	707 V DC (type test)	707 V DC (type test)
Decentralized operation		
Supports fast startup	No	No
Dimensions		
Width	35 mm	35 mm
Height	147 mm	147 mm
Depth	129 mm	129 mm
Weight		
Weight, approx.	310 g	300 g
Other		
Note:	Additional basic error and noise for integration time = 2.5 ms: Voltage: +/- 250 mV: +/- 0.02% +/- 80 mV: +/- 0.05% +/- 50 mV: +/- 0.05% resistance: 150 ohms: +/- 0.02% resistance thermometer: Pt100 climate: +/- 0.08 K Ni100 climate: +/-0.08 K thermocouple: Type B, R, S: +/- 3 K type E, J, K, N, T: +/-1 K	

SIMATIC S7-1500

Analog modules

SM 531 analog input modules

Ordering data

SM 531 analog input modules

8 analog inputs ± 10 V, ± 5 V,
1 ... 5 V or 0/4 ... 20 mA, ± 20 mA,
16 bit + sign

8 analog inputs
 ± 10 V, ± 5 V, ± 2.5 V, ± 1 V,
 ± 500 mV, ± 250 mV, ± 80 mV,
 ± 50 mV, 1 ... 5 V, 0/4 ... 20 mA,
 ± 20 mA,
thermocouples type
B, E, J, K, N, R, S, T,
resistance thermometers
Ni 100, Ni 1000, LG-Ni 1000, Pt 100,
Pt 1000, Pt 250, Pt 500,
resistors 0... 150/300/600/6000 Ohm,
16 bit

Order No.

6ES7 531-7NF10-0AB0

6ES7 531-7KF00-0AB0

Order No.

Accessories

Front connectors

Including four potential bridges,
cable ties, and individual labeling
strips; 40-pole screw-type terminal

6ES7 592-1AM00-0XB0

DIN A4 labeling sheets

10 sheets with 10 labeling strips
each for I/O modules; perforated,
Al grey

6ES7 592-2AX00-0AA0

U connector

5 units; spare part

6ES7 590-0AA00-0AA0

Universal front door for I/O modules

5 front doors; with 5 labeling strips
(front) and 5 cabling diagrams per
front door; spare part

6ES7 528-0AA00-7AA0

Shielding set I/O

Infeed element, shield clamp, and
shield terminal;
5 units, spare part

6ES7 590-5CA00-0AA0

Shield terminal element

10 units; spare part

6ES7 590-5BA00-0AA0

Overview



- 4 and 8-channel analog output modules
- Optionally with extremely short conversion times
- For connecting analog actuators without additional amplifiers
- Even solves more complex automation tasks

Technical specifications

	6ES7 532-5HD00-0AB0 AQ 4xU/I ST	6ES7 532-5HF00-0AB0 AQ 8xU/I HS
General information		
Product function		
• I&M data	Yes; IM0 to IM3	Yes; IM0 to IM3
Engineering with		
• STEP 7 TIA Portal can be configured/integrated as of version	V12.0 / V12.0	V12.0 / V12.0
• STEP 7 can be configured/integrated as of version	as of V5.5 SP3 / -	as of V5.5 SP3 / -
CiR - Configuration in RUN		
Reparameterization possible in RUN	Yes	Yes
Calibration possible in RUN	Yes	Yes
Supply voltage		
Type of supply voltage	DC	DC
Rated voltage/DC	24 V	24 V
Reverse polarity protection	Yes	Yes
Analog outputs		
Number of analog outputs	4	8
Cycle time (all channels), min.	3.2 ms; (independent of number of activated channels)	125 µs; (independent of number of activated channels)
Output ranges, voltage		
• 0 to 10 V	Yes	Yes
• 1 to 5 V	Yes	Yes
• -10 to +10 V	Yes	Yes
Output ranges, current		
• 0 to 20 mA	Yes	Yes
• -20 to +20 mA	Yes	Yes
• 4 to 20 mA	Yes	Yes
Connection of actuators		
• for voltage output 2-conductor connection	Yes	Yes
• for voltage output 4-conductor connection	Yes	Yes
• for current output 2-conductor connection	Yes	Yes
Load impedance (in rated range of output)		
• with voltage outputs, min.	1 kΩ; 0.5 kΩ at 1 to 5 V	1 kΩ
• with voltage outputs, capacitive load, max.	1 µF	100 nF
• with current outputs, max.	750 Ω	500 Ω
• with current outputs, inductive load, max.	10 mH	1 mH
Cable length		
• Cable length, shielded, max.	800 m; for current, 200 m for voltage	200 m

SIMATIC S7-1500

Analog modules

SM 532 analog output modules

Technical specifications (continued)

	6ES7 532-5HD00-0AB0 AQ 4xU/I ST	6ES7 532-5HF00-0AB0 AQ 8xU/I HS
Analog value creation		
Integrations and conversion time/ resolution per channel		
• Conversion time (per channel)	0.5 ms	50 µs
Settling time		
• for resistive load	1.5 ms	30 µs; (see additional description in the manual)
• for capacitive load	2.5 ms	100 µs; (see additional description in the manual)
• for inductive load	2.5 ms	100 µs; (see additional description in the manual)
Isochronous mode		
Isochronous operation (application synchronized up to terminal)		Yes
Execution and activation time (TCO), min.		100 µs
Bus cycle time (TDP), min.		250 µs
Interrupts/diagnostics/status information		
Substitute values connectable	Yes	Yes
Alarms		
• Diagnostic alarm	Yes	Yes
Diagnostic messages		
• Diagnostics	Yes	Yes
• Monitoring the supply voltage	Yes	Yes
• Wire break	Yes; Only for output type "current"	Yes; Only for output type "current"
• Short circuit	Yes; Only for output type "voltage"	Yes; Only for output type "voltage"
• Overflow/underflow	Yes	Yes
Diagnostics indication LED		
• RUN LED	Yes; Green LED	Yes; Green LED
• ERROR LED	Yes; Red LED	Yes; Red LED
• Monitoring the supply voltage	Yes; Green LED	Yes; Green LED
• Channel status display	Yes; Green LED	Yes; Green LED
• for channel diagnostics	Yes; Red LED	Yes; Red LED
• for module diagnostics	Yes; Red LED	Yes; Red LED
Galvanic isolation		
Electrical isolation channels		
• between the channels and the backplane bus	Yes	Yes
Isolation		
Isolation checked with	707 V DC (type test)	707 V DC (type test)
Decentralized operation		
Supports fast startup	Yes; 500 ms	Yes; 500 ms
Dimensions		
Width	35 mm	35 mm
Height	147 mm	147 mm
Depth	129 mm	129 mm
Weight		
Weight, approx.	310 g	325 g

Ordering data	Order No.	Order No.	
SM 532 analog output modules 4 analog outputs ±10 V, 1 ... 5 V, 0 ... 10 V or ±20 mA, 0/4 ... 20 mA, 16 bit 8 analog outputs ±10 V, 1 ... 5 V, 0 ... 10 V or ±20 mA, 0/4 ... 20 mA, 16 bit	6ES7 532-5HD00-0AB0 6ES7 532-5HF00-0AB0	U connector 5 units; spare part	6ES7 590-0AA00-0AA0
Accessories Front connectors Including four potential bridges, cable ties, and individual labeling strips; 40-pole screw-type terminal	6ES7 592-1AM00-0XB0	Universal front door for I/O modules 5 front doors; with 5 labeling strips (front) and 5 cabling diagrams per front door; spare part	6ES7 528-0AA00-7AA0
DIN A4 labeling sheets 10 sheets with 10 labeling strips each for I/O modules; perforated, Al grey	6ES7 592-2AX00-0AA0	Shielding set I/O Infeed element, shield clamp, and shield terminal; 5 units; spare part	6ES7 590-5CA00-0AA0
		Shield terminal element 10 units; spare part	6ES7 590-5BA00-0AA0

SIMATIC S7-1500

SIPLUS analog modules

SIPLUS SM 531 analog input modules

Overview



- 8-channel analog input modules
- Optionally with extremely short conversion times
- For the connection of analog sensors without additional amplifiers
- Even solves more complex automation tasks

Note:

SIPLUS extreme products are based on Siemens Industry standard products. The contents listed here were taken from the respective standard products. SIPLUS extreme-specific information was added.

Technical specifications

The technical data correspond to those of the based-on modules apart from the values listed in the table:

based on	6AG1 531-7KF00-7AB0 6ES7 531-7KF00-0AB0
Ambient conditions	
Operating temperature	
• Horizontal mounting position	-25...+70 °C
• Vertical mounting position	-25...+50 °C
Extended ambient conditions	
• with reference to ambient temperature, air pressure and altitude	Tmin ... Tmax at 1080 hPa ... 795 hPa (-1000 m ... +2000 m) // Tmin ... (Tmax - 10K) at 795 hPa ... 658 hPa (+2000 m ... +3500 m) // Tmin ... (Tmax - 20K) at 658 hPa ... 540 hPa (+3500 m ... +5000 m)
Relative humidity	
• with condensation / maximum / tested in accordance with IEC 60068-2-38	100%; RH incl. condensation/frost (no commissioning in bedewed state)
Resistance	
• to biologically active substances / compliance with EN 60721-3-3	Yes; Class 3B2 mold and fungal spores (except fauna); the supplied plug covers must remain in place on the unused interfaces during operation.
• to chemically active substances / compliance with EN 60721-3-3	Yes; Class 3C4 (RH < 75%) incl. salt spray in accordance with EN 60068-2-52 (severity 3); the supplied plug covers must remain in place on the unused interfaces during operation.
• to mechanically active substances / compliance with EN 60721-3-3	Yes; Class 3S4 incl. sand, dust; the supplied plug covers must remain in place on unused interfaces during operation.

Ordering data

Order No.

SIPLUS SM 531 analog input modules

(extended temperature range and medial exposure)

8 analog inputs
 ± 10 V, ± 5 V, ± 2.5 V, ± 1 V, ± 500 mV,
 ± 250 mV, ± 80 mV, ± 50 mV, 1 ... 5 V,
 0/4 ... 20 mA, ± 20 mA,
 thermocouples type B, E, J, K, N, R,
 S, T, resistance thermometers
 Ni 100, Ni 1000, LG-Ni 1000, Pt 100,
 Pt 1000, Pt 250, Pt 500,
 resistors
 0...150/300/600/6000 Ohm,
 16 bit

6AG1 531-7KF00-7AB0

Accessories

See SIMATIC S7-1500 SM 531 analog input modules, page 4/22

Overview



- 4-channel analog output modules
- Optionally with extremely short conversion times
- For connecting analog actuators without additional amplifiers
- Even solves more complex automation tasks

Note:

SIPLUS extreme products are based on Siemens Industry standard products. The contents listed here were taken from the respective standard products. SIPLUS extreme-specific information was added.

Technical specifications

The technical data correspond to those of the based-on modules apart from the values listed in the table:

based on	6AG1 532-5HD00-7AB0 6ES7 532-5HD00-0AB0
Ambient conditions	
Operating temperature	
• Horizontal mounting position	-25...+70 °C
• Vertical mounting position	-25...+50 °C
Extended ambient conditions	
• with reference to ambient temperature, air pressure and altitude	Tmin ... Tmax at 1080 hPa ... 795 hPa (-1000 m ... +2000 m) // Tmin ... (Tmax - 10K) at 795 hPa ... 658 hPa (+2000 m ... +3500 m) // Tmin ... (Tmax - 20K) at 658 hPa ... 540 hPa (+3500 m ... +5000 m)
Relative humidity	
• with condensation / maximum / tested in accordance with IEC 60068-2-38	100%; RH incl. condensation/frost (no commissioning in bedewed state)
Resistance	
• to biologically active substances / compliance with EN 60721-3-3	Yes; Class 3B2 mold and fungal spores (except fauna); the supplied plug covers must remain in place on the unused interfaces during operation.
• to chemically active substances / compliance with EN 60721-3-3	Yes; Class 3C4 (RH < 75%) incl. salt spray in accordance with EN 60068-2-52 (severity 3); the supplied plug covers must remain in place on the unused interfaces during operation.
• to mechanically active substances / compliance with EN 60721-3-3	Yes; Class 3S4 incl. sand, dust; the supplied plug covers must remain in place on unused interfaces during operation.

Ordering data

Order No.

SIPLUS SM 532 analog output modules

(extended temperature range and medial exposure)

4 analog outputs,
±10 V, 1 ... 5 V, 0 ... 10 V or
±20 mA, 0/4 ... 20 mA, 16 bit

6AG1 532-5HD00-7AB0

Accessories

See SIMATIC S7-1500 SM 532 analog output modules, page 4/25

SIMATIC S7-1500

Technology modules

TM Count 2x24V counter modules

Overview



- 2-channel high-speed counter module
- With comprehensive parameterization options for an optimum adaptation to the task and reduction of control load
- Speed and time period measuring
- Storage and comparison functions
- Connection of 24 V encoders

4

Technical specifications

6ES7 550-1AA00-0AB0 TM Count 2x24V	
General information	
Product function	
• I&M data	Yes; I&M 0
Engineering with	
• STEP 7 TIA Portal can be configured/integrated as of version	V12.0 / V12.0
• STEP 7 can be configured/integrated as of version	as of V5.5 SP3 / -
• PROFINET as of GSD version/GSD revision	V2.3
Installation type/mounting	
Mounting rail installation possible	Yes; S7-1500 mounting rail
Supply voltage	
Load voltage L+	
• Rated value (DC)	24 V
• permissible range, lower limit (DC)	19.2 V
• permissible range, upper limit (DC)	28.8 V
• Reverse polarity protection	Yes
Input current	
Current consumption, max.	75 mA; without load
Encoder supply	
Number of outputs	1; A common 24 V encoder supply for both channels
24 V encoder supply	
• 24 V	Yes; L+ (-0.8 V)
• Short-circuit protection	Yes
• Output current, max.	1 A; total current of all encoders/channels
Power	
Power available from the backplane bus	1.3 W
Power losses	
Power loss, typ.	4 W
Digital inputs	
Number/binary inputs	6; 3 per channel
Digital inputs, configurable	Yes
Input characteristic curve acc. to IEC 61131, Type 3	Yes
Digital input functions, parameterizable	
• Gate start/stop	Yes
• Capture	Yes
• Synchronization	Yes
• Freely usable digital input	Yes

6ES7 550-1AA00-0AB0 TM Count 2x24V	
Input voltage	
• Type of input voltage	DC
• Rated value, DC	24 V
• for signal "0"	-30 to +5 V
• for signal "1"	+11 to +30 V
• Permissible voltage at input, max.	30 V
• Permissible voltage at input, min.	-30 V
Input current	
• for signal "1", typ.	2.5 mA
Input delay (for rated value of input voltage)	
• for standard inputs	
- Parameterizable	Yes; none / 0.05 / 0.1 / 0.4 / 0.8 / 1.6 / 3.2 / 12.8 / 20 ms
- at "0" to "1", min.	6 µs; for parameterization "none"
- at "1" to "0", min.	6 µs; for parameterization "none"
• for counter/technological functions	
- Parameterizable	Yes
Cable length	
• Cable length, shielded, max.	1 000 m
• Cable length unshielded, max.	600 m
Digital outputs	
Type of digital output	Transistor
Number/binary outputs	4; 2 per channel
Digital outputs, configurable	Yes
Functionality/short-circuit strength	Yes; electronic/thermal
Limitation of inductive shutdown voltage to	L+ (-33 V)
Controlling a digital input	Yes
Digital output functions, parameterizable	
• Switching tripped by comparison values	Yes
• Freely usable digital output	Yes
Switching capacity of the outputs	
• with resistive load, max.	0.5 A; Per digital output
• on lamp load, max.	5 W
Load resistance range	
• lower limit	48 Ω
• upper limit	12 kΩ

Technical specifications (continued)

6ES7 550-1AA00-0AB0 TM Count 2x24V	
Output voltage	
• Type of output voltage	DC
• for signal "1", min.	23.2 V; L+ (-0.8 V)
Output current	
• for signal "1" rated value	0.5 A; Per digital output
• for signal "1" permissible range, max.	0.6 A; Per digital output
• for signal "1" minimum load current	2 mA
• for signal "0" residual current, max.	0.5 mA
Output delay with resistive load	
• "0" to "1", max.	50 µs
• "1" to "0", max.	50 µs
Switching frequency	
• with resistive load, max.	10 kHz
• with inductive load, max.	0.5 Hz; Acc. to IEC 947-5-1, DC-13; observe derating curve
• on lamp load, max.	10 Hz
Aggregate current of the outputs	
• Max. current per module	2 A
Cable length	
• Cable length, shielded, max.	1 000 m
• Cable length unshielded, max.	600 m
Encoder	
Connectable encoders	
• 2-wire sensor	Yes
- Permissible quiescent current (2-wire sensor), max.	1.5 mA
Encoder signals, incremental encoder (asymmetrical)	
• Input frequency, max.	200 kHz
• Counting frequency, max.	800 kHz; with quadruple evaluation
• Signal filter, can be parameterized	Yes
• Cable length, shielded, max.	600 m; depending on input frequency, encoder and cable quality; max. 50 m at 200 kHz
• Incremental encoder with A/B tracks, 90° out of phase	Yes
• Incremental encoder with A/B tracks, 90° out of phase and zero track	Yes
• Pulse encoder	Yes
• Pulse encoder with direction	Yes
• Pulse encoder with one impulse signal per count direction	Yes
• Encoder signal 24 V	
- Permissible voltage at input, max.	30 V
- minimum permissible	-30 V
Interface types	
• Input characteristic curve in accordance with IEC 61131, type 3	Yes
• m/p-reading	Yes
Isochronous mode	
Isochronous operation (application synchronized up to terminal)	Yes
Filtering and processing time (TCI), min.	130 µs
Bus cycle time (TDP), min.	250 µs
Interrupts/diagnostics/status information	
Alarms	
• Diagnostic alarm	Yes
• Hardware interrupt	Yes

6ES7 550-1AA00-0AB0 TM Count 2x24V	
Diagnostic messages	
• Monitoring the supply voltage	Yes
• Wire break	Yes
• Short circuit	Yes
• A/B transition error at incremental encoder	Yes
Diagnostics indication LED	
• RUN LED	Yes; Green LED
• ERROR LED	Yes; Red LED
• Monitoring the supply voltage	Yes; Green LED
• Channel status display	Yes
• for channel diagnostics	Yes
• Status indicator backward counting (green)	Yes
• Status indicator forward counting (green)	Yes
Integrated Functions	
Number of counters	2
Counter frequency (counter) max.	800 kHz; with quadruple evaluation
Counting functions	
• Continuous counting	Yes
• Hardware gate via digital input	Yes
• Software gate	Yes
• Event-controlled stop	Yes
• Synchronization via digital input	Yes
• Counting range, parameterizable	Yes
• Comparator	
- Number of comparators	2; Per channel
- Direction dependency	Yes
- Can be changed from user program	Yes
Position detection	
• Incremental acquisition	Yes
• Suitable for S7-1500 Motion Control	Yes
Measuring functions	
• Measuring time, parameterizable	Yes
• Dyn. measuring time adjustment	Yes
• Number of thresholds, parameterizable	2
• Measuring range	
- Frequency measurement, max.	800 kHz
- Frequency measurement, min.	0.04 Hz
- Period measurement, max.	25 s
- Period measurement, min.	1.25 µs
• Accuracy	
- Frequency measurement	100 ppm; depending on measuring interval and signal evaluation
- Speed measurement	100 ppm; depending on measuring interval and signal evaluation
- Cycle duration measurement	100 ppm; depending on measuring interval and signal evaluation
Galvanic isolation	
Electrical isolation channels	
• between the channels	No
• between the channels and the backplane bus	Yes
• between the channels and the load voltage L+	No
Permissible potential difference	
between different circuits	75 VDC / 60 VAC
Isolation	
Isolation checked with	707 V DC

SIMATIC S7-1500

Technology modules

TM Count 2x24V counter modules

Technical specifications (continued)

	6ES7 550-1AA00-0AB0 TM Count 2x24V
Ambient conditions	
Operating temperature	0 °C
• horizontal installation, min.	60 °C; Please note derating for inductive loads
• horizontal installation, max.	0 °C
• vertical installation, min.	40 °C; Please note derating for inductive loads
• vertical installation, max.	
Decentralized operation	
to SIMATIC S7-1500	Yes
to standard PROFINET controller	Yes
Dimensions	
Width	35 mm
Height	147 mm
Depth	129 mm
Weight	
Weight, approx.	250 g

Ordering data

Order No.

TM Count 2x24V counter module	6ES7 550-1AA00-0AB0
With 2 channels, max. 200 kHz; for 24 V encoder	
Accessories	
Front connectors	6ES7 592-1AM00-0XB0
Including four potential bridges, cable ties, and individual labeling strips; 40-pole screw-type terminal	
DIN A4 labeling sheets	6ES7 592-2AX00-0AA0
10 sheets with 10 labeling strips each for I/O modules; perforated, Al grey	
U connector	6ES7 590-0AA00-0AA0
5 units; spare part	
Universal front door for I/O modules	6ES7 528-0AA00-7AA0
5 front doors; with 5 labeling strips (front) and 5 cabling diagrams per front door; spare part	
Shielding set I/O	6ES7 590-5CA00-0AA0
Infeed element, shield clamp, and shield terminal; 5 units, spare part	
Shield terminal element	6ES7 590-5BA00-0AA0
10 units; spare part	

Overview



- Modules for serial communication connections, scaled according to interface types, protocols, and performance
- 4 versions with different physical transmission characteristics:
 - RS 232C, max. 19.2 Kbit/s
 - RS 232C, max. 115.2 Kbit/s
 - RS 422/RS 485, max. 19.2 Kbit/s
 - RS 422/RS 485, max. 115.2 Kbit/s
- Protocols supported
 - Freeprot: User-parameterizable telegram format for universal communication
 - 3964(R) for improved transmission reliability
 - Modbus RTU Master
 - Modbus RTU Slave
 - USS, implemented through instructions

Technical specifications

	6ES7 540-1AD00-0AA0 CM PtP RS232 BA	6ES7 541-1AD00-0AB0 CM PtP RS232 HF	6ES7 540-1AB00-0AA0 CM PtP RS422/485 BA	6ES7 541-1AB00-0AB0 CM PtP RS422/485 HF
General information				
Product function				
• I&M data	Yes; I&M 0	Yes; I&M 0	Yes; I&M 0	Yes; I&M 0
Engineering with				
• STEP 7 TIA Portal can be configured/integrated as of version	V12.0 / V12.0	V12.0 / V12.0	V12.0 / V12.0	V12.0 / V12.0
• STEP 7 can be configured/integrated as of version	V5.5 SP2 or higher with a GSD file	V5.5 SP2 or higher with a GSD file	V5.5 SP2 or higher with a GSD file	V5.5 SP2 or higher with a GSD file
• PROFINET as of GSD version/ GSD revision	V2.3	v2.3 / -	V2.3	v2.3 / -
Installation type/mounting				
Mounting rail installation possible	Yes; S7-1500 mounting rail possible	Yes; S7-1500 mounting rail	Yes; S7-1500 mounting rail	Yes; S7-1500 mounting rail
Supply voltage				
Type of supply voltage	system power supply	system power supply	system power supply	system power supply
Input current				
Current consumption (rated value)	35 mA; From the backplane bus	35 mA; From the backplane bus	33 mA; From the backplane bus	33 mA; From the backplane bus
Power				
Power available from the backplane bus	0.65 W	0.65 W	0.65 W	0.65 W
Power losses				
Power loss, typ.	0.6 W	0.6 W	0.6 W	0.6 W
Interfaces				
1st interface				
• Interface types				
- RS 232	Yes	Yes	Yes	Yes
- RS 422			Yes	Yes
- RS 485			Yes	Yes
Interface types				
RS 232				
• Transmission rate, max.	19.2 kbit/s	115.2 kbit/s		
• Cable length, max.	15 m	15 m		
• RS-232 accompanying signals	RTS, CTS, DTR, DSR, RI, DCD	RTS, CTS, DTR, DSR, RI, DCD		
RS 485				
• Transmission rate, max.			19.2 kbit/s	115.2 kbit/s
• Cable length, max.			1 200 m	1 200 m
RS 422				
• Maximum			19.2 kbit/s	115.2 kbit/s
• Cable length, max.			1 200 m	1 200 m
• 4-wire full duplex connection			Yes	Yes
• 4-wire multipoint connection			No	No

SIMATIC S7-1500

Communication

CM PtP

Technical specifications (continued)

	6ES7 540-1AD00-0AA0 CM PtP RS232 BA	6ES7 541-1AD00-0AB0 CM PtP RS232 HF	6ES7 540-1AB00-0AA0 CM PtP RS422/485 BA	6ES7 541-1AB00-0AB0 CM PtP RS422/485 HF
Protocols				
Integrated protocols				
• Freeprot				
- Telegram length, max.	1 kbyte	4 kbyte	1 kbyte	4 kbyte
- Bits per character	7 or 8	7 or 8	7 or 8	7 or 8
- Number of stop bits	1 or 2 bit	1 or 2 bit	1 or 2 bit	1 or 2 bit
- Parity	None, even, odd, always 1, always 0, any	None, even, odd, always 1, always 0, any	None, even, odd, always 1, always 0, any	None, even, odd, always 1, always 0, any
• 3964 (R)				
- Telegram length, max.	1 kbyte	4 kbyte	1 kbyte	4 kbyte
- Number of bits per character	7 or 8	7 or 8	7 or 8	7 or 8
- Number of stop bits	1 or 2 bit	1 or 2 bit	1 or 2 bit	1 or 2 bit
- Parity	None, even, odd, always 1, always 0, any	None, even, odd, always 1, always 0, any	None, even, odd, always 1, always 0, any	None, even, odd, always 1, always 0, any
• Modbus RTU master				
- Address area		1 to 247, extended 1 to 65 535		1 to 247, extended 1 to 65 535
- Number of slaves, max.		1		32
• MODBUS RTU slave				
- Address area		1 to 247, extended 1 to 65 535		1 to 247, extended 1 to 65 535
Frame buffer				
• Buffer memory for message frames	2 kbyte	8 kbyte	2 kbyte	8 kbyte
• Number of message frames which can be buffered	255	255	255	255
Interrupts/diagnostics/status information				
Alarms				
• Diagnostic alarm	Yes	Yes	Yes	Yes
• Hardware interrupt	No	No	No	No
Diagnostic messages				
• Diagnostics	Yes	Yes	Yes	Yes
• Wire break	Yes	Yes	Yes	Yes
Diagnostics indication LED				
• RUN LED	Yes; Green LED	Yes; Green LED	Yes; Green LED	Yes; Green LED
• ERROR LED	Yes; Red LED	Yes; Red LED	Yes; Red LED	Yes; Red LED
• Receive RxD	Yes; yellow LED	Yes; yellow LED	Yes; yellow LED	Yes; yellow LED
• Send TxD	Yes; yellow LED	Yes; yellow LED	Yes; yellow LED	Yes; yellow LED
Galvanic isolation				
Between the backplane bus and interface	Yes	Yes	Yes	Yes
Isolation				
Isolation checked with	707 V DC (type test)	707 V DC (type test)	707 V DC (type test)	707 V DC (type test)
Ambient conditions				
Operating temperature				
• horizontal installation, min.	0 °C	0 °C	0 °C	0 °C
• horizontal installation, max.	60 °C	60 °C	60 °C	60 °C
• vertical installation, min.	0 °C	0 °C	0 °C	0 °C
• vertical installation, max.	40 °C	40 °C	40 °C	40 °C
Decentralized operation				
to SIMATIC S7-300	Yes	Yes	Yes	Yes
to SIMATIC S7-400	Yes	Yes	Yes	Yes
to SIMATIC S7-1500	Yes	Yes	Yes	Yes
to standard PROFINET controller	Yes	Yes	Yes	Yes
Supports fast startup	Yes	Yes	Yes	Yes
Dimensions				
Width	35 mm	35 mm	35 mm	35 mm
Height	147 mm	147 mm	147 mm	147 mm
Depth	127 mm	127 mm	127 mm	127 mm
Weight				
Weight, approx.	0.22 kg	0.22 kg	0.22 kg	0.22 kg

Ordering data	Order No.	Order No.
CM PtP RS232 BA communication module Basic communication module with 1 interface RS232, Freeport, 3964(R) and USS protocols, 9-pin sub D connector, max. 19.2 Kbit/s	6ES7 540-1AD00-0AA0	Accessories RS 232 connecting cable For linking to SIMATIC S7 5 m 6ES7 902-1AB00-0AA0 10 m 6ES7 902-1AC00-0AA0 15 m 6ES7 902-1AD00-0AA0 RS 422/485 connecting cable For linking to SIMATIC S7 5 m 6ES7 902-3AB00-0AA0 10 m 6ES7 902-3AC00-0AA0 50 m 6ES7 902-3AG00-0AA0
CM PtP RS232 HF communication module High Feature communication module with 1 interface RS232, Freeport, 3964(R), USS and Modbus RTU protocols, 9-pin sub D connector, max. 115.2 Kbit/s	6ES7 541-1AD00-0AB0	
CM PtP RS422/485 BA communication module Basic communication module with 1 interface RS422/485, Freeport, 3964(R) and USS protocols, 15-pin sub D socket, max. 19.2 Kbit/s	6ES7 540-1AB00-0AA0	
CM PtP RS422/485 HF communication module High Feature communication module with 1 interface RS422/485, Freeport, 3964(R), USS and Modbus RTU protocols, 15-pin sub D socket, max. 115.2 Kbit/s	6ES7 541-1AB00-0AB0	

SIMATIC S7-1500

Communication

CM 1542-5

Overview



DP-M	DP-S	FMS	PG/OP	S7/S5	
●	●		●	●	

The CM 1542-5 communication module expands the SIMATIC S7-1500 controller with an additional PROFIBUS connection for communication with lower-level PROFIBUS devices in bandwidths from 9.6 kbps to 12 Mbps. The module also allows the implementation of separate PROFIBUS lines; in other words, the control of multiple field devices via several PROFIBUS segments. The CM 1542-5 handles all communication tasks, thus reducing the CPU load.

Apart from classic PROFIBUS communication; the CM 1542-5 is also suitable for S7 communication. This makes it possible to establish communication between the S7-1500 controller and other devices, for example those from the SIMATIC S7-300/400 range.

- PROFIBUS DP master or DP slave with electrical interface for connecting the SIMATIC S7-1500 to PROFIBUS at up to 12 Mbps (including 45.45 Kbps)
- Communication services:
 - PROFIBUS DP
 - PG/OP communication
 - S7 communication
- Time synchronization
- Simple programming and configuration over PROFIBUS
- Cross-network PG communication using S7 routing
- Module replacement without a PG
- Data record routing (PROFIBUS DP)
- Adding or modifying distributed I/O during operation

Technical specifications

Order No.	6GK7 542-5DX00-0XE0
Product-type designation	CM 1542-5
Transmission rate	
Transmission rate at interface 1	
• in accordance with PROFIBUS	9.6 kbit/s ... 12 Mbit/s
Interfaces	
Number of electrical connections at interface 1	
• in accordance with PROFIBUS	1
Design of electrical connection at interface 1	
• in accordance with PROFIBUS	9-pin Sub-D socket (RS485)
Supply voltage, current consumption, power loss	
Type of voltage of supply voltage	DC
Supply voltage 1	
• from backplane bus	15 V
Resistive loss	3 W
Permitted ambient conditions	
Ambient temperature	
• for vertical installation during operating phase	0 ... 40 °C
• for horizontal installation during operating phase	0 ... 60 °C
• during storage	-40 ... +70 °C
• during transport	-40 ... +70 °C
• Comment	-
Relative humidity at 25 °C without condensation during operating maximum	95 %
Protection class IP	IP20
Design, dimensions and weight	
Module format	
Width	35 mm
Height	142 mm
Depth	129 mm
Net weight	0.4 kg
Type of mounting	Yes
S7-1500 rail mounting	
Product properties, functions, components general	
Number of modules	
• per CPU maximum	8
• note	depending on CPU type

Technical specifications (continued)		Ordering data	Order No.
Order No.	6GK7 542-5DX00-0XE0	CM 1542-5 communication module 1)	
Product-type designation	CM 1542-5	Communication module for electrical connection of SIMATIC S7-1500 to PROFIBUS as a DP master or DP slave	6GK7 542-5DX00-0XE0
Performance data		Accessories	
<u>Performance data PROFIBUS DP</u>		PROFIBUS FastConnect connector RS485	
Service as DP master DPV1	Yes	With 90° cable outlet; insulation displacement technology, max. transmission rate 12 Mbps	
Number of DP slaves on DP master usable	125	• Without PG interface	6ES7 972-0BA52-0XA0
Amount of data		• with PG interface	6ES7 972-0BB52-0XA0
• of the address area of the inputs as DP master overall	8 192 byte	PROFIBUS FC Standard Cable	
• of the address area of the outputs as DP master overall	8 192 byte	2-core bus cable, shielded, special design for fast mounting, delivery unit: max. 1000 m, minimum order 20 m, sold by the meter	6XV1 830-0EH10
• of the address area of the inputs per DP slave	244 byte	PROFIBUS FastConnect Stripping Tool	
• of the address area of the outputs per DP slave	244 byte	Stripping tool for fast stripping of the PROFIBUS FastConnect bus cable	6GK1 905-6AA00
• of the address area of the diagnostic data per DP slave	-	PROFIBUS bus terminal 12M	
Service as DP slave		Bus terminal for connection of PROFIBUS nodes up to 12 Mbps with plug-in cable	6GK1 500-0AA10
• DPV0	Yes	Engineering software STEP 7 Professional V12	
• DPV1	Yes	Target system: SIMATIC S7-1200, S7-1500, S7-300, S7-400, WinAC, SIMATIC Basic Panels	
Amount of data		Requirement: Microsoft Windows XP Professional SP3 (32 bit) Microsoft Windows 7 Professional SP1 (32/64 bit) Microsoft Windows 7 Enterprise SP1 (32/64 bit) Microsoft Windows 7 Ultimate SP1 (32/64 bit) Microsoft Server 2003 R2 Std. SP2 (32 bit) Microsoft Server 2008 Std. SP2 (32/64 bit)	
• of the address area of the inputs as DP slave overall	240 byte	Type of delivery: German, English, Chinese, Italian, French, Spanish	
• of the address area of the outputs as DP slave overall	240 byte	STEP 7 Professional V12, floating license	6ES7 822-1AA02-0YA5
<u>Performance data S7 communication</u>			
Number of possible connections for S7 communication			
• maximum	40		
• note			
<u>Performance data multi-protocol mode</u>			
Number of active connections with multi-protocol mode			
Product functions management, configuration			
Configuration software required			
Product functions Time			
Product function pass on time synchronization	Yes		

1) Available soon

SIMATIC S7-1500

Communication

CP 1543-1

Overview



ISO	TCP/UDP	PN	MRP	IT	IP-R	PG/OP	S7/S5
●	●			●		●	●

The SIMATIC CP 1543-1 communications processor securely connects the new SIMATIC S7-1500 controller to Industrial Ethernet networks. By combining a variety of security features such as an SPI (Stateful Packet Inspection) firewall and data encryption protocols such as FTPS and SNMPv3, the communications processor protects individual S7-1500 stations or even entire automation cells against unauthorized access.

The CP can also be used for linking the S7-1500 station into an IPv6-based network. All functions are configured with STEP 7 Professional V12 of the TIA Portal V12.

The CP 1543-1 supports the following communications services:

- PG/OP communication
- S7 communication
- Open communication (SEND/RECEIVE, FETCH/WRITE)
- IT communication
 - FTP functions (File Transfer Protocol FTP/FTPS) for file management and access to data blocks in the CPU (client and server function)
 - Sending e-mails via SMTP or ESMTP with "SMTP-Auth" for authentication on an e-mail server (also with IPv6).
- Security functions
 - Stateful Packet Inspection (layers 3 and 4) firewall
 - For monitoring purposes, events can be stored in log files that can be read using the configuration tool or sent automatically to a Syslog server.
 - Secure file transfer using FTPS.
 - Secure NTP for secure time synchronization and transfer.
 - SNMPv3 for tap-proof transfer of network analysis information
- Linking the S7-1500 into IPv6 based networks. For the following communications services, an IP address according to IPv6 can be used:
 - FETCH/WRITE access (CP as server)
 - FTP server mode
 - FTP client mode with addressing by program block
 - E-mail transfer with addressing by program block

Technical specifications

Order No.	6GK7 543-1AX00-0XE0
Product-type designation	CP 1543-1
Transmission rate	
Transfer rate	
• at the interface 1	10 ... 1 000 Mbit/s
Interfaces	
Number of electrical connections	1
• at interface 1 in accordance with Industrial Ethernet	
Design of electrical connection	
• at interface 1 in accordance with Industrial Ethernet	RJ45 port
Supply voltage, current consumption, power loss	
Type of voltage of supply voltage	DC
Supply voltage 1 from backplane bus	15 V
Resistive loss	5,3 W
Permitted ambient conditions	
Ambient temperature	
• for vertical installation during operating phase	0 ... 40 °C
• for horizontal installation during operating phase	0 ... 60 °C
• during storage	-40 ... +70 °C
• during transport	-40 ... +70 °C
Relative humidity at 25 °C without condensation during operating maximum	95 %
Protection class IP	IP20
Design, dimensions and weight	
Module format	
Width	35 mm
Height	142 mm
Depth	129 mm
Net weight	0,35 kg
Type of mounting	Yes
S7-1500 rail mounting	
Product properties, functions, components general	
Number of modules	
• per CPU maximum	8
• note	depending on CPU type
Performance data	
Number of possible connections for open communication by means of T blocks maximum	118
Data volume as user data per ISO on TCP connection for open communication by means of T blocks maximum	65 536 byte
Number of Multicast stations	118

Technical specifications (continued)		Ordering data	Order No.
Order No.	6GK7 543-1AX00-0XE0	CP 1543-1 communications processor ¹⁾	6GK7 543-1AX00-0XE0
Product-type designation	CP 1543-1	for connection of SIMATIC S7-1500 to Industrial Ethernet via TCP/IP, ISO and UDP and Security functions; 1 x RJ45 interface with 10/100/1000 Mbit/s; electronic manual on DVD	
Performance data S7 communication		Accessories	
Number of possible connections for S7 communication	118	IE FC TP Standard Cable GP 2 x 2 (Type A)	6XV1 840-2AH10
• maximum		4-core, shielded TP installation cable for connection to IE FC outlet RJ45/IE FC RJ45 plug; PROFINET-compatible; with UL approval; sold in meters, max. quantity 1000 m, minimum order 20 m	
• note			
Performance data multi-protocol mode		IE FC TP Standard Cable GP 4x2	
Number of active connections with multiprotocol mode	118	8-core, shielded TP installation cable for connection to IE FC RJ45 Modular Outlet for universal application; with UL approval; sold by the meter, max quantity 1000 m, minimum order 20 m	
Performance data IT functions		• AWG22, for connection to IE FC RJ45 Modular Outlet	6XV1 870-2E
Number of possible connections		• AWG24, for connection to IE FC RJ45 Plug 4 x 2	6XV1 878-2A
• as client by means of FTP maximum	32	Industrial Ethernet Switch SCALANCE X204-2	6GK5 204-2BB10-2AA3
• as server		Industrial Ethernet switches with integral SNMP access, online diagnostics, copper cable diagnostics and PROFINET diagnostics for configuring line, star and ring topologies; four 10/100 Mbit/s RJ45 ports and two fiber-optic cable ports	
- by means of FTP maximum	16	Industrial Ethernet Switch SCALANCE X308-2	6GK5 308-2FL00-2AA3
- by means of HTTP maximum	4	2 x 1000 Mbit/s multimode fiber-optic cable ports (SC sockets), 1 x 10/100/1000 Mbit/s RJ45 port, 7 x 10/100 Mbit/s RJ45 ports; for glass fiber-optic cable (multimode) up to max. 750 m	
• as e-mail client maximum	1	IE FC RJ45 Plug 180 2 x 2	
Amount of data as useful data for e-mail maximum	64 Kibyte	RJ45 plug connector for Industrial Ethernet with a rugged metal housing and integrated insulation-displacement/terminal contacts for connecting Industrial Ethernet FC installation cables; with a 180° cable outlet; for network components and CPs/CPU with Industrial Ethernet interface	
Product functions management, configuration		• 1 pack = 1 unit	6GK1 901-1BB10-2AA0
Product function MIB support	Yes	• 1 pack = 10 units	6GK1 901-1BB10-2AB0
Protocol is supported		• 1 pack = 50 units	6GK1 901-1BB10-2AE0
• SNMP v1	Yes		
• DCP	Yes		
• LLDP	No		
Configuration software required			
Identification & maintenance			
• I&M0 - device-specific information	Yes		
• I&M1 - plant identification/location name	Yes		
Product functions Security			
Design of the firewall	stateful inspection		
Product function			
• switchoff of non-required services	Yes		
• blocking of communication via physical ports	No		
• log file for unauthorized access	Yes		
Product functions Time			
Product function			
• SICLOCK support	Yes		
• pass on time synchronization	Yes		
Protocol is supported NTP	Yes		

¹⁾ Available soon

SIMATIC S7-1500

Communication

CP 1543-1

Ordering data**Order No.****Order No.****IE FC RJ45 Plug 4 x 2**

RJ45 plug connector for Industrial Ethernet (10/100/1000 Mbit/s) with a rugged metal enclosure and integrated insulation displacement contacts for connecting Industrial Ethernet FC installation cables; 180° cable outlet; for network components and CPs/CPU with Industrial Ethernet interface

- 1 pack = 1 unit
- 1 pack = 10 units
- 1 pack = 50 units

6GK1 901-1BB11-2AA0**6GK1 901-1BB11-2AB0****6GK1 901-1BB11-2AE0****IE FC Stripping Tool**

Preadjusted stripping tool for fast stripping of the Industrial Ethernet FC cables

6GK1 901-1GA00**Engineering Software STEP 7 Professional V12****Target system:**

SIMATIC S7-1200, S7-1500, S7-300, S7-400, WinAC, SIMATIC Basic Panels

Requirement:

Microsoft Windows XP Professional SP3 (32 bit)
 Microsoft Windows 7 Professional SP1 (32/64 bit)
 Microsoft Windows 7 Enterprise SP1 (32/64 bit)
 Microsoft Windows 7 Ultimate SP1 (32/64 bit)
 Microsoft Server 2003 R2 Std. SP2 (32 bit)
 Microsoft Server 2008 Std. SP2 (32/64 bit)

Type of delivery:

German, English, Chinese, Italian, French, Spanish

STEP 7 Professional V12, floating license

6ES7 822-1AA02-0YA5

4

Overview



- Uniform 40-pin front connector, suitable for all 35 mm wide SIMATIC S7-1500 I/O modules
- With screw-type terminals (push-in terminals available soon)
- To be ordered separately.
- Connectable core cross-sections: 0.25 mm² to 1.5 mm² (AWG 24 to 16)

Ordering data

Order No.

Front connectors

Including four potential bridges, cable ties, and individual labeling strips; 40-pole screw-type terminal

6ES7 592-1AM00-0XB0

Potential bridges for front connectors

20 units; spare part

6ES7 592-3AA00-0AA0

SIMATIC S7-1500

Connection system

SIMATIC TOP connect system cabling
for SIMATIC S7-1500 and ET 200MP

Overview



With two cabling systems, SIMATIC TOP connect ensures efficient wiring of the input and output module of the SIMATIC S7-1500: Fully modular connection for fast and clearly arranged connecting to sensors and actuators in the field, and flexible connection for simple wiring inside the control cabinet.

With the TIA Selection Tool, you can select suitable system cabling for the individual I/O modules with a simple mouse click. Suitable components for the respective I/O module are always offered. These can be transferred to the order list and then ordered in the Industry Mall.

Further information can be found on the Internet at

<http://www.siemens.com/tia-selection-tool>

Design

Two cabling variants are available for a wide range of control cabinet concepts:

Fully modular connection

The system consists of:

- Front connector module
- Connecting cable
- Terminal modules in the following versions: Basic module, signal module and function module

Connection errors are thus practically excluded and installation overhead is significantly reduced. Systematic connection of the SIMATIC system. The assembly overhead for the connecting cables is drastically reduced thanks to the use of pre-assembled or easily assembled cables sold by the meter.

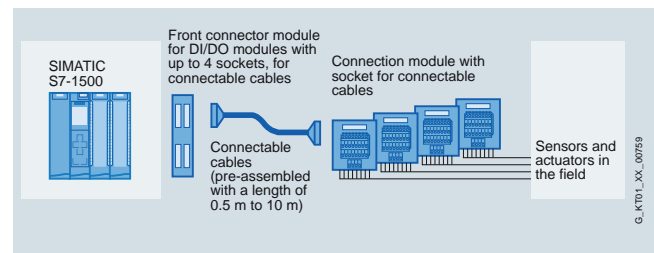

Flexible connection

Flexible connection with front connectors is available with 20 (Pin1 – 20) or 40 wired single cores.

These are available in lengths from 2.5 m to 10.0 m.

The single cores are available in different versions:

- Core type H05V-K is used for industrial applications
- The UL/CSA-approved core is available for export to North America
- The halogen-free version is used where low smoke gas density in the event of fire is required, e.g. in building automation

The blue wires are numbered sequentially and can be routed directly to each element in the control cabinet. The numbering of the single cores corresponds to the coding of the front connector contacts.

In comparison to conventional single wiring, there is a cost saving of 50 % for assembly, since the single cores that have already been checked on the connector are fixed.

Complex pre-assembly of up to two times 40 single cores per module is no longer necessary.

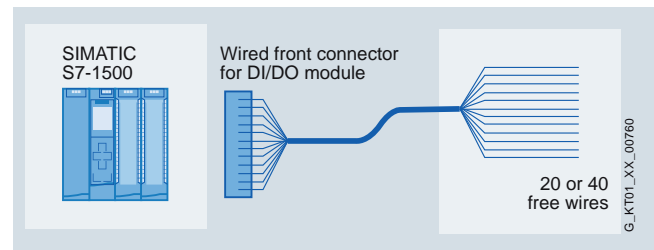

SIMATIC S7-1500

Connection system

SIMATIC TOP connect for SIMATIC S7 Fully modular connection

Overview



The fully modular connection for connecting to the I/O modules of the SIMATIC S7-1500 or ET 200MP consists of modified front connectors, called front connector modules, preassembled connecting cables of various lengths, and terminal modules. Suitable components can be selected for the application in question and joined by means of simple plug-in connections. The terminal modules are used instead of conventional terminal blocks and act as the interface to the sensors and actuators.

Benefits

- Easy plugging in of front connector module, connecting cable and terminal module
- Fast and low-cost wiring
- In the case of digital signals, the supply voltage can be connected to the front connector module or the terminal module
- Reduction in wiring errors, clear control cabinet wiring
- Byte-by-byte distribution of the signals in the case of digital signals
- Each component can be replaced individually
- Every cable length can be configured without cutting, or pre-assembled cables can be used

Design

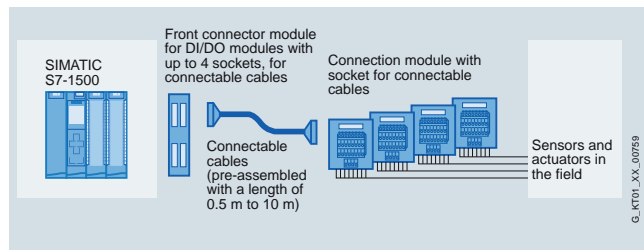

Front connector module

Modified front connectors, called front connector modules, are available for connecting to the I/O modules. These are plugged into the I/O module to be wired instead of the front connector. The front connector modules are available in the most diverse versions for digital I/O modules and for the 24 V 2-ampère module. The connecting cables are plugged into these front connector modules.

Connecting cable

The connecting cable is available in two different versions.

As a pre-assembled 16-pole round cable (shielded or unshielded) up to a length of 10 m or the round-sheath ribbon cable to be simply used. The round-sheath ribbon cable is available 16-pole shielded as well as 2 x 16-pole without shield.

When assembled, there are one or two insulation displacement connectors (female ribbon connectors) at both ends of the cable.

The round-sheath ribbon cable is assembled by the user with the aid of pliers (can be ordered separately). The cable transmits 8 or 2 x 8 channels over a distance of up to 30 m.

The connecting cable connects the front connector module with the terminal module.

Terminal module

The system has digital and analog terminal modules for connecting the I/O signals. These are snapped onto the standard mounting rail.

Terminal modules are available for two different connection methods: as spring-loaded or screw-type terminals. The potential can be fed in at the terminal module or at the front connector module.

Basic module:

Terminal modules with basic functionality for getting the signal from the field to the module or from the module to the field quickly and easily. For digital signals.

Signal module:

Expands the digital basic module with LEDs for signaling the active high signal. This makes commissioning easier for you, and you always have an overview of the signal states of your I/O. One LED signals the availability of the supply voltage.

Function module:

Digital terminal modules that are fitted with relays or optocouplers.

If other voltage or power levels are required in the field, the terminal module for output signals TPRo or TPOo is used. For the TPRo terminal module, relays are used for the implementation. For the TPOo terminal module, optocouplers are used for the implementation. This converts the 24 V DC output signal simply and reliably to another voltage or power level. If 230 V AC input signals have to be transmitted to the controller in the field, a terminal module with relay TPRI is available that simply converts the 230 V AC signal to 24 V DC. This means that there is always the same voltage level on the module side.

Use with optocouplers for the TPRo relay modules

If higher switching frequencies of the relay terminal module are required for the output signals, the relay can simply be replaced with an optocoupler (note technical specifications) in order to increase the switching frequency here.

SIMATIC S7-1500

Connection system

SIMATIC TOP connect for SIMATIC S7 Fully modular connection

Technical specifications Front connector module

Rated operating voltage	DC 24 V
Max. permissible operating voltage	DC 60 V
Max. permissible continuous current • per connector pin	1 A
Max. permissible total current	4 A/Byte
Permissible ambient temperature	0 bis + 60 °C
Test voltage	0.5 kV, 50 Hz, 60 s
Air gaps and creepage distances	IEC 664 (1980), IEC 664 A (1981), acc. to DIN VDE 0110 (01.89), overvoltage class II, pollution degree 2

Wiring rules for the front connector modules

SIMATIC TOP connect front connector module, connection for potential infeed

	Push-in	Screw terminals
	Modules up to 4 connections	
Connectable cable cross-sections • Solid conductors • Flexible cables with/without wire end ferrule	No 0.25 to 1.5 mm ²	
Number of conductors per connection	1 or a combination of 2 wires up to 1.5 mm ² (total) in a common wire end ferrule	
Max. diameter of the cable insulation	3.1 mm	
Stripping length of the wires • Without insulating collar • with insulating collar	6 mm -	
Wire end ferrules according to DIN 46228 • Without insulating collar • with insulating collar 0.25 to 1.0 mm ² • with insulating collar 1.5 mm ²	Form A; 5 to 7 mm long - -	
Blade width of the screwdriver	3.5 mm (cylindrical design)	
Tightening torque for connecting the cables	-	0.4 to 0.7 Nm

Technical specifications Connecting cable

Technical data of connecting cable from SIMATIC S7 to connection module

Operating voltage	60 V DC
Continuous current per signal conductor	1 A
Max. summation current	4 A/byte
Operating temperature	0 to +60°C
Outer diameter of pre-assembled round cable in mm, unshielded/shielded	Approx. 6.5/7.0
Outer diameter of round-sheath ribbon cable in mm, 16-pole/2 x 16-pole	Approx. 9.5/11.5

Technical specifications Basic module

Connection module TP1, TP3 and TPK

Max. operating voltage	60 V DC
Continuous current per signal	1 A
Max. summation current (voltage infeed)	4 A/byte
Operating temperature	0 to + 60°C
Mounting position	Any
Air gaps and creepage distances	IEC Report 664, IEC 664 A, IEC 1131 T2, CSA C22.2 No 142 UL 508, VDE 0160 (12.90), overvoltage category II, pollution degree 3

Dimensions (W x H x D) in mm

• 1-wire connection 6ES7924-0AA10-0A_0	Approx. 55 x 43.2 x 63
• for 3-wire initiators 6ES7924-0CA10-0A_0	Approx. 68 x 43.2 x 80
• for 2 x 8 signals 6ES7924-1AA10-0A_0	Approx. 100 x 43.2 x 80

Connection module TP2

Max. operating voltage	60 V DC
Continuous current signal conductor	2 A
Operating temperature	0 to + 60°C
Mounting position	Any
Air gaps and creepage distances	IEC Report 664, IEC 664 A, IEC 1131 T2, CSA C22.2 No 142 UL 508, VDE 0160 (12.90), overvoltage category II, pollution degree 3

Dimensions (W x H x D) in mm

• for 2 ampere modules 6ES7924-0BB10-0A_0	Approx. 68 x 43.2 x 80
--	------------------------

Connection module TPA

Max. operating voltage	60 V DC
Continuous current signal conductor	1 A
Operating temperature	0 to + 60°C
Mounting position	Any
Air gaps and creepage distances	IEC Report 664, IEC 664 A, IEC 1131 T2, CSA C22.2 No 142 UL 508, VDE 0160 (12.90), overvoltage category II, pollution degree 3

Dimensions (W x H x D) in mm

• for 2 analog modules 6ES7924-0CC10-0A_0	Approx. 68 x 43.2 x 80
--	------------------------

SIMATIC S7-1500

Connection system

SIMATIC TOP connect for SIMATIC S7 Fully modular connection

Technical specifications Basic module (continued)

Wiring rules for connection modules

Connection module TPA, TP1, TP2, TP3, TPK		
	Spring connection	Screw connection
Connectable cable cross-sections		
• solid cables	No	
• flexible cables without wire end ferrule	0.5 to 2.5 mm ²	
• flexible cables with wire end ferrule in accordance with DIN 46228/1	0.5 to 1.5 mm ²	0.5 to 2.5 mm ² (2.5 mm ² with a crimp in accordance with EN 60947-1)
• flexible cables with wire end ferrule and plastic collar in accordance with DIN 46228/4	0.5 to 1.5 mm ²	
Number of cables per connection	1 or a combination of 2 cables up to the cross-sections specified above (total) in a shared wire end ferrule	
Blade width of the screwdriver	3.5 mm (cylindrical shape)	
Tightening torque for connecting the cables	-	0.4 to 0.7 Nm

Technical specifications Signal module

Connection module TP1, TP3 and TPK with LED	
Max. operating voltage	24 V DC
Continuous current per signal	1 A
Max. summation current (voltage infeed)	4 A/byte
Operating temperature	0 to + 60 °C
Mounting position	Any
Air gaps and creepage distances	IEC Report 664, IEC 664 A, IEC 1131 T2, CSA C22.2 No 142 UL 508, VDE 0160 (12.90), overvoltage category II, pollution degree 3
Dimensions (W x H x D) in mm	
• 1-wire connection with LED 6ES7924-0AA10-0B_0	Approx. 55 x 43.2 x 63
• for 3-wire initiators with LED 6ES7924-0CA10-0B_0	Approx. 68 x 43.2 x 80
• for 2 x 8 signals with LED 6ES7924-1AA10-0B_0	Approx. 100 x 43.2 x 80
Connection module TP2 with LED	
Max. operating voltage	24 V DC
Continuous current per signal conductor	2 A
Operating temperature	0 to + 60 °C
Mounting position	Any
Air gaps and creepage distances	IEC Report 664, IEC 664 A, IEC 1131 T2, CSA C22.2 No 142 UL 508, VDE 0160 (12.90), overvoltage category II, pollution degree 3
Dimensions (W x H x D) in mm	
• for 2-ampere modules with LED 6ES7924-0BB10-0B_0	Approx. 68 x 43.2 x 80

Wiring rules for connection modules

Connection module TP1 LED, TPK LED, TP2 LED, TP3 LED

	Spring connection	Screw connection
Connectable cable cross-sections		
• solid cables	No	
• flexible cables without wire end ferrule	0.5 to 2.5 mm ²	
• flexible cables with wire end ferrule in accordance with DIN 46228/1	0.5 to 1.5 mm ²	0.5 to 2.5 mm ² (2.5 mm ² with a crimp in accordance with EN 60947-1)
• flexible cables with wire end ferrule and plastic collar in accordance with DIN 46228/4	0.5 to 1.5 mm ²	
Number of wires per connection	1 or a combination of 2 conductors up to the cross-sections specified above (total) in a shared wire end ferrule	
Blade width of the screwdriver	3.5 mm (cylindrical shape)	
Tightening torque for connecting the cables	-	0.4 to 0.7 Nm

Technical specifications Function module

Connection module with relay for outputs (TPRo)	
Energizing side	
Operating voltage for coil	24 V DC
Input circuit	Reverse polarity protection and freewheeling diodes
Contact side	
Number of relay outputs	8 (NO contacts)
Contact design	Single contact, 1 NO contact
Switching capacity (resistive load)	max. 4 A/250 V AC max. 3 A/30 V DC max. 0.6 A/48 V DC max. 0.4 A/60 V DC recommended minimum load ≥ 10 mA
Switching frequency	20 cycles/minute
Service life	
• Mechanical	5 x 10 ⁶ switching cycles
• Electrical	3 x 10 ⁴ operating cycles at 230 V AC/2 A/ cos γ = 1
Operating temperature	0 ... +60 °C
Mounting position	Any
Clearance and creepage distances	Basic standard IEC 60664-1; UL 508; Cul (Reference CSA C22.2 No. 142) Overvoltage category III Pollution degree 2
Dimensions (W x H x D) in mm	
6ES7924-0BD10-0B_0	Approx. 100 x 45 x 80

SIMATIC S7-1500

Connection system

SIMATIC TOP connect for SIMATIC S7
Fully modular connection

Technical specifications Function module (continued)

Connection module with optocoupler for outputs (TPOo)

Input data	
Power supply	
Potential connection (L1/M1)	24 V DC (20.4 ... 28.8 V DC)
Status indicator "L1"	Green LED
Switching inputs	
Number	8 channels (channel 0 ... 7) with reverse polarity protection
Input voltage "off"	0 V DC (0 ... 5 V DC)
Input voltage "on"	24 V DC (15 ... 28.8 V DC)
Input current	min. 5 mA with 20 V DC, per channel
Status indicator "on"	Green LED per channel
Output data	
Power supply	
Operating voltage U_B (L2/M2, L3/M3)	24 V DC (20 ... 30 V DC) per group of 4 one V_B
U_B conditionally protected against polarity reversal ¹⁾	Up to 30 V DC
Current consumption	approx. 10 mA for 24 V DC + output currents per group of 4
Aggregate current	max. 8 A per group of 4
Switching outputs	
Number	8 channels (channel 0 ... 7)
Short-circuit protection ²⁾	for $U_B < 24$ V DC or 24 ... 30 V DC/max. 20 A
Output voltage	typ. $U_B - 1$ V (for input "on")
Output current	Max. 4 A per channel
• Lamp load	max. 20 W at 24 V per channel
Demand factor per group of 4	50 %, max. 2 outputs active under full load (4 A)
Short-circuit response	Clocked output signal (approx. 2 ... 20 ms)
On/off-delay	typ. 100 μ s/250 μ s with resistive load
Switching frequency	max. 500 Hz with 4 A resistive load (square wave voltage, pulse/pause 1:1)
"Overload" fault indication	Red LED per channel, in the event of wire breakage or short-circuit
• Wire break indication	Active $I_{out} < 0.1$ A/ inactive $I_{out} \geq 0.9$ A
Group fault messages SF1, SF2	
Monitored channels	SF1: Channels 0 ... 3, SF2: for channels 4 ... 7
Voltage U_{SF1} , U_{SF2}	typ. $U_B - 2$ V Approx. 0 V
• No error at the switching output	
• Wire break at the switching output	
• Short-circuit at the switching output	0 V to U_B , clocked
Current I_{SF1} , I_{SF2}	min. 4 mA/max. 200 mA
General data	
Degree of protection	IP20
Operating temperature	0 ... 60 °C
Mounting position	Any, except overhead
Connecting terminals	Screw-type or spring-loaded terminals
Stripped length	9 mm
Conductor cross-section	0.5 ... 2.5 mm ²
• Finely stranded without end sleeve	
• with end sleeve for screw-type terminals	0.5 ... 2.5 mm ² according to DIN 46228-1
• with end sleeve for spring-loaded terminals	0.5 ... 1.5 mm ² according to DIN 46228-1 and DIN 46228-4

Screwdriver	according to DIN 5264 B 0.6 x 3.5 mm
Tightening torque of screw-type terminals	0.4 Nm
Weight	Approx. 400 g
Dimensions (W x H x D) in mm	134 x 84 x 77
Connection module with relay for inputs (TPRi)	
Energizing side	
Operating voltage for coil	230 V AC from 207 – 280 V AC
Input circuit	Varistors
Contact side	
Number of relay outputs	8 (NO contacts)
Contact design	Single contact, 1 NO contact
Switching capacity (resistive load)	max. 50 A/24 V AC, max. 50 mA/48 V DC max. 50 mA/60 V DC recommended minimum load ≥ 5 mA
Switching frequency	200 cycles/minute
Service life	
• Mechanical	10 x 10 ⁶ switching cycles
• Electrical	3 x 10 ⁶ operating cycles at 230 V AC/50 mA/cos $\gamma = 1$
Operating temperature	0 ... +60 °C
Mounting position	Any
Clearance and creepage distances	Basic standard IEC 60664-1; UL 508; Cul (Reference CSA C22.2 No. 142) Overvoltage category III Pollution degree 2
Dimensions (W x H x D) in mm	
6ES7924-0BE10-0B_0	Approx. 130 x 45 x 80

Wiring rules for the connection modules

Connection modules TPRO and TPRi

	Spring-loaded connection	Screw-type connection
Connectable cable cross-sections		
• Solid conductors	No	
• Flexible cables without end sleeve	0.5 ... 2.5 mm ²	
• Flexible cables with end sleeve according to DIN 46228/1	0.5 ... 1.5 mm ²	0.5 to 2.5 mm ² (2.5 mm ² with a crimp in accordance with EN 60947-1)
• Flexible cables with end sleeve and plastic collar according to DIN 46228/4	0.5 ... 1.5 mm ²	
Number of conductors per connection	1 or a combination of 2 conductors up to the cross-sections specified above (total) in a shared end sleeve	
Blade width of the screwdriver	3.5 mm (cylindrical design)	
Tightening torque for connecting the cables	-	0.4 ... 0.7 Nm

¹⁾ Protected against polarity reversal, if the ground potential of the output load is directly connected to the 0 V supply of the power supply unit

²⁾ Not sustained short-circuit-proof, max. duration approx. 60 min.

SIMATIC S7-1500

Connection system

SIMATIC TOP connect for SIMATIC S7
Fully modular connection

4

Ordering data	Order No.
Front connector module	
Front connector module (digital 4 x 8 I/O)	
Power supply via	
• Push-in	6ES7 921-5AH20-0AA0
• Screw-type terminals	6ES7 921-5AB20-0AA0
Front connector module (1 x 8 outputs) for 2-ampère digital outputs	
Power supply via	
• Push-in	6ES7 921-5AJ00-0AA0
• Screw-type terminals	6ES7 921-5AD00-0AA0

Ordering data	Order No.
Connecting cable	
Pre-assembled round cable	
<u>16-pole, 0.14 mm²</u>	
Unshielded	
• 0.5 m	6ES7923-0BA50-0CB0
• 1.0 m	6ES7923-0BB00-0CB0
• 1.5 m	6ES7923-0BB50-0CB0
• 2.0 m	6ES7923-0BC00-0CB0
• 2.5 m	6ES7923-0BC50-0CB0
• 3.0 m	6ES7923-0BD00-0CB0
• 4.0 m	6ES7923-0BE00-0CB0
• 5.0 m	6ES7923-0BF00-0CB0
Shielded	
• 1.0 m	6ES7923-0BB00-0DB0
• 2.0 m	6ES7923-0BC00-0DB0
• 2.5 m	6ES7923-0BC50-0DB0
• 3.0 m	6ES7923-0BD00-0DB0
• 4.0 m	6ES7923-0BE00-0DB0
• 5.0 m	6ES7923-0BF00-0DB0
Round-sheath ribbon cable	
<u>16-pole, 0.14 mm²</u>	
Unshielded	
• 30 m	6ES7923-0CD00-0AA0
• 60 m	6ES7923-0CG00-0AA0
Shielded	
• 30 m	6ES7923-0CD00-0BA0
• 60 m	6ES7923-0CG00-0BA0
Round-sheath ribbon cable	
<u>2 x 16-pole, 0.14 mm²</u>	
Unshielded	
• 30 m	6ES7923-2CD00-0AA0
• 60 m	6ES7923-2CG00-0AA0
Connector (female ribbon connector)	6ES7921-3BE10-0AA0
16-pole, insulation displacement system, with strain relief devices; packing unit: 8 connectors and 8 cable grips	
Accessories	
Manual pliers	6ES7928-0AA00-0AA0
For preparing the connectors (female ribbon connector)	

Ordering data	Order No.
Basic module	
Connection module TP1	
for 1-wire initiators	
Packaging unit (1 unit)	
• Spring terminals	6ES7924-0AA10-0AB0
• Screw terminals	6ES7924-0AA10-0AA0
Connection module TP3	
for 3-wire initiators	
Packaging unit (1 unit)	
• Spring terminals	6ES7924-0CA10-0AB0
• Screw terminals	6ES7924-0CA10-0AA0
Connection module TPK	
for 2 x 8 signals	
Packaging unit (1 unit)	
• Spring terminals	6ES7924-1AA10-0AB0
• Screw terminals	6ES7924-1AA10-0AA0
Connection module TP2	
for 2 A modules	
for 2-wire initiators	
Packaging unit (1 unit)	
• Spring terminals	6ES7924-0BB10-0AB0
• Screw terminals	6ES7924-0BB10-0AA0
Connection module TPA	
for analog signals	
Packaging unit (1 unit)	
• Spring terminals	6ES7924-0CC10-0AB0
• Screw terminals	6ES7924-0CC10-0AA0
Accessories	
Labeling plates	
for connection modules	
Insertable labeling plate PU = 200 units	6ES7928-2AB00-0AA0
Self-adhesive labeling plate PU = 200 units	6ES7928-2BB00-0AA0
Shield plate	6ES7928-1BA00-0AA0
for analog connection module (4 units)	
Shield connection terminal	
for shield plate, 2 units, with cable diameter	
• 2 to 6 mm (2 cables)	6ES7390-5AB00-0AA0
• 3 to 8 mm	6ES7390-5BA00-0AA0
• 4 to 13 mm	6ES7390-5CA00-0AA0

SIMATIC S7-1500

Connection system

SIMATIC TOP connect for SIMATIC S7
Fully modular connection

4

Ordering data	Order No.
Signal module	
Connection module TP1 with LED for 1-wire initiators Packaging unit (1 unit) • Spring terminals • Screw terminals	6ES7924-0AA10-0BB0 6ES7924-0AA10-0BA0
Connection module TP3 with LED for 3-wire initiators Packaging unit (1 unit) • Spring terminals • Screw terminals	6ES7924-0CA10-0BB0 6ES7924-0CA10-0BA0
Connection module TPK with LED for 2 x 8 signals Packaging unit (1 unit) • Spring terminals • Screw terminals	6ES7924-1AA10-0BB0 6ES7924-1AA10-0BA0
Connection module TP2 with LED for 2 A modules for 2-wire initiators Packaging unit (1 unit) • Spring terminals • Screw terminals	6ES7924-0BB10-0BB0 6ES7924-0BB10-0BA0
Accessories	
Labeling plates for connection modules	
Insertable labeling plates PU = 200 units	6ES7928-2AB00-0AA0
Self-adhesive labeling plates PU = 200 units	6ES7928-2BB00-0AA0

Ordering data	Order No.
Function module	
Connection module TPRo for output signals for 2-wire connection Packaging unit 1 unit • Spring-loaded terminals • Screw-type terminals	6ES7924-0BD10-0BB0 6ES7924-0BD10-0BA0
Connection module optocoupler Packaging unit 1 unit • Spring-loaded terminals • Screw-type terminals	6ES7924-0BF10-0BB0 6ES7924-0BF10-0BA0
Connection module TPRi for input signals for 2-wire connection Packaging unit 1 unit • Spring-loaded terminals • Screw-type terminals	6ES7924-0BE10-0BB0 6ES7924-0BE10-0BA0
Accessories	
Labeling plates for connection modules	
Insertable labeling plates PU = 200 units	6ES7928-2AB00-0AA0
Self-adhesive labeling plates PU = 200 units	6ES7928-2BB00-0AA0
Replacement relay for relay connection module PU = 4 units	
Replacement relay for TPRi	6ES7928-3BA00-4AA0
Replacement relay for TPRo	6ES7928-3AA00-4AA0
Optocoupler DC alternative for relay in the case of TPRo PU = 4 units	6ES7928-3DA00-4AA0
Optocoupler AC alternative for relay in the case of TPRo PU = 4 units	6ES7928-3CA00-4AA0

Overview



Flexible connection of the cabling system consists of a S7-1500 front connector which has the 20 or 40 single cores already in place and which directly connects the I/O modules with the sensors and actuators inside the control cabinet. With a cross-section of 0.5 square mm, the single wires are also suitable for higher currents and are available in different lengths and versions: as H05V-K cores (PVC insulation), H05Z-K (halogen-free insulation) or with UL/CSA certified cores. The halogen-free version has a low smoke gas density in the event of a fire and is thus particularly well suited for use in buildings.

Technical specifications

Front connector with single cores for 16 channels (pins 1-20)	
Rated operating voltage	24 V DC
Permissible continuous current with simultaneous load of all cores, max.	1.5 A
Permissible ambient temperature	0 to 60 °C
Core type	H05V-K, UL 1007/1569; CSA TR64, or halogen-free
Number of single cores	20
Core cross-section	0.5 mm ² ; Cu
Bundle diameter in mm	Approx. 15
Core color	Blue, RAL 5010
Designation of cores	Numbered from 1 to 20 (front connector contact = core number)
Assembly	Screw contacts

Front connector with single cores for 32 channels (pins 1-40)	
Rated operating voltage	24 V DC
Permissible continuous current with simultaneous load of all cores, max.	1.5 A
Permissible ambient temperature	0 to 60 °C
Core type	H05V-K, UL 1007/1569; CSA TR64, or halogen-free
Number of single cores	40
Core cross-section	0.5 mm ² ; Cu
Bundle diameter in mm	Approx. 17
Core color	Blue, RAL 5010
Designation of cores	Numbered from 1 to 40 (front connector contact = core number)
Assembly	Screw-type or crimp contacts

Ordering data

Order No.

Front connector with single cores for 32 channels (pins 1-40)

Core type H05V-K (0.5 mm² with screwed connection)

- 2.5 m
- 3.2 m
- 5.0 m
- 6.5 m
- 8.0 m
- 10.0 m

6ES7 922-5BC50-0AC0
6ES7 922-5BD20-0AC0
6ES7 922-5BF00-0AC0
6ES7 922-5BG50-0AC0
6ES7 922-5BJ00-0AC0
6ES7 922-5CB00-0AC0

Core type H05Z-K, halogen-free (0.5 mm² with screwed connection)

- 2.5 m
- 3.2 m
- 5.0 m
- 6.5 m
- 8.0 m
- 10.0 m

6ES7 922-5BC50-0HC0
6ES7 922-5BD20-0HC0
6ES7 922-5BF00-0HC0
6ES7 922-5BG50-0HC0
6ES7 922-5BJ00-0HC0
6ES7 922-5CB00-0HC0

Core type UL/CSA-certified (0.5 mm² with screw connection)

- 3.2 m
- 5.0 m
- 6.5 m

6ES7 922-5BD20-0UC0
6ES7 922-5BF00-0UC0
6ES7 922-5BG50-0UC0

Front connector with single cores for 16 channels (pins 1-20)

Core type H05V-K (0.5 mm² with screwed connection)

- 2.5 m
- 3.2 m
- 5.0 m
- 6.5 m
- 8.0 m
- 10.0 m

6ES7 922-5BC50-0AB0
6ES7 922-5BD20-0AB0
6ES7 922-5BF00-0AB0
6ES7 922-5BG50-0AB0
6ES7 922-5BJ00-0AB0
6ES7 922-5CB00-0AB0

Core type H05Z-K, halogen-free (0.5 mm² with screwed connection)

- 2.5 m
- 3.2 m
- 5.0 m
- 6.5 m
- 8.0 m
- 10.0 m

6ES7 922-5BC50-0HB0
6ES7 922-5BD20-0HB0
6ES7 922-5BF00-0HB0
6ES7 922-5BG50-0HB0
6ES7 922-5BJ00-0HB0
6ES7 922-5CB00-0HB0

Core type UL/CSA-certified (0.5 mm² with screw connection)

- 3.2 m
- 5.0 m
- 6.5 m

6ES7 922-5BD20-0UB0
6ES7 922-5BF00-0UB0
6ES7 922-5BG50-0UB0

SIMATIC S7-1500

Power supplies

System power supplies

Overview



- Power supplies for the SIMATIC S7-1500
- For conversion of AC or DC line voltages to the operating voltages required for the internal electronics
- 25 or 60 W output power
- Can be used for S7-1500 or ET 200MP
- Configuration via STEP 7 V12

4

Technical specifications

	6ES7 505-0KA00-0AB0 PS 25W 24VDC	6ES7 505-0RA00-0AB0 PS 60W 24/48/60V DC	6ES7 507-0RA00-0AB0 PS 60W 120/230V AC/DC
General information			
Hardware product version	E01	E01	E01
Engineering with			
• STEP 7 TIA Portal can be configured/ integrated as of version	V12.0 / V12.0	V12.0 / V12.0	V12.0 / V12.0
FH technology			
Redundancy			
• Redundant capability - for increased power	Yes Yes	Yes Yes	Yes Yes
Supply voltage			
Rated voltage/DC	24 V; SELV		
permissible range, lower limit (DC)	Static 19.2 V, dynamic 18.5 V	Static 19.2 V, dynamic 18.5 V	88 V
permissible range, upper limit (DC)	Static 28.8 V, dynamic 30.2 V	Static 72 V, dynamic 75.5 V	300 V
permissible range, lower limit (AC)			85 V
permissible range, upper limit (AC)			264 V
Reverse polarity protection	Yes	Yes	
Short-circuit protection	Yes	Yes	Yes
Line frequency			
• Rated value 50 Hz • Frequency of the supply voltage • Frequency of the supply voltage			Yes 47 Hz 63 Hz
Mains buffering			
• Mains buffering time	20 ms	20 ms	20 ms
Input current			
Rated value at 48 V DC		1.5 A	
Rated value at 60 V DC		1.2 A	
Rated value at 120 V DC			0.6 A
Rated value at 230 V DC			0.3 A
Rated value at 120 V AC			0.6 A
Rated value at 230 V AC			0.34 A
Output current			
Short-circuit protection	Yes	Yes	Yes

Technical specifications (continued)

	6ES7 505-0KA00-0AB0 PS 25W 24VDC	6ES7 505-0RA00-0AB0 PS 60W 24/48/60V DC	6ES7 507-0RA00-0AB0 PS 60W 120/230V AC/DC
Power			
Infeed power to the backplane bus	25 W	60 W	60 W
Power losses			
Power loss at nominal rating conditions	6.2 W	12 W	12 W
Interrupts/diagnostics/status information			
Status indicator	Yes	Yes	Yes
Galvanic isolation			
primary/secondary	Yes	Yes	Yes
Isolation			
Isolation checked with	707 V DC (type test)		
EMC			
Surge immunity • on the supply lines acc. to IEC 61000-4-5	Yes	Yes	Yes
Degree and class of protection			
Protection class	3; with protective conductor	1; with protective conductor	1; with protective conductor
Dimensions			
Width	35 mm	70 mm	70 mm
Height	147 mm	147 mm	147 mm
Depth	129 mm	129 mm	129 mm
Weight			
Weight, approx.	350 g	600 g	600 g

Ordering data

Ordering data	Order No.	Ordering data	Order No.
Power supply		Accessories	
For supplying the backplane bus of the S7-1500		SIMATIC S7-1500 mounting rail	
24 V DC input voltage, power 25 W	6ES7 505-0KA00-0AB0	Fixed lengths, with grounding elements	
24/48/60 V DC input voltage, power 60 W	6ES7 505-0RA00-0AB0	• 160 mm	6ES7 590-1AB60-0AA0
120/230 V AC input voltage, power 60 W	6ES7 507-0RA00-0AB0	• 482 mm	6ES7 590-1AE80-0AA0
		• 530 mm	6ES7 590-1AF30-0AA0
		• 830 mm	6ES7 590-1AJ30-0AA0
		For cutting to length by customer, without drill holes; grounding elements must be ordered separately	
		• 2000 mm	6ES7 590-1BC00-0AA0
		PE connection element for mounting rail 2000 mm	6ES7 590-5AA00-0AA0
		Spare part, 20 units	
		Power connector	6ES7 590-8AA00-0AA0
		With coding element for power supply module; spare part, 10 units	

SIMATIC S7-1500

Power supplies

Load power supplies

Application



The design and functionality of the SIMATIC PM 1507 single-phase load power supply (PM = power module) with automatic range selection of the input voltage are an optimal match to the SIMATIC S7-1500 PLC. It supplies the S7-1500 system components such as CPU, system power supply (PS), I/O circuits of the input and output modules and, if necessary, the sensors and actuators with 24 V DC.

4

Technical specifications

Order No.	6EP1 332-4BA00	6EP1 333-4BA00
Product	S7-1500 PM1507	S7-1500 PM1507
Power supply, type	24 V/3 A	24 V/8 A
Input		
Input	1-phase AC	1-phase AC
Supply voltage	120 V	120 V
• 1 for AC rated value	230 V	230 V
• 2 for AC rated value	Automatic range selection	Automatic range selection
• Note		
Input voltage	85 ... 132 V	85 ... 132 V
• 1 for AC	170 ... 264 V	170 ... 264 V
• 2 for AC		
Overshoot strength	$2.3 \times U_{in \text{ rated}}$, 1.3 ms	$2.3 \times U_{in \text{ rated}}$, 1.3 ms
Mains buffering at $I_{out \text{ rated}}$, min.	20 ms	20 ms
Mains buffering	at $U_{in} = 93/187 \text{ V}$	at $U_{in} = 93/187 \text{ V}$
Rated line frequency	50 Hz	50 Hz
• 1	60 Hz	60 Hz
• 2		
Line frequency range	45 ... 65 Hz	45 ... 65 Hz
Input current		
• at rated value of input voltage 120 V rated value	1.4 A	3.7 A
• at rated value of input voltage 230 V rated value	0.8 A	1.7 A
Switch-on current limitation (+ 25 °C), max.	23 A	62 A
I^2t , max.	1.3 A ² ·s	12 A ² ·s
Built-in input fuse	T 3.15 A/250 V (not accessible)	T 6.3 A/250 V (not accessible)
Protection in the supply feeder (IEC 898)	Recommended miniature circuit breaker: 10 A, characteristic B or 6 A, characteristic C	Recommended miniature circuit breaker: 16 A, characteristic B or 10 A, characteristic C

Order No.	6EP1 332-4BA00	6EP1 333-4BA00
Product	S7-1500 PM1507	S7-1500 PM1507
Power supply, type	24 V/3 A	24 V/8 A
Output		
Output	Controlled, isolated DC voltage	Controlled, isolated DC voltage
Rated voltage $U_{out \text{ rated}}$ DC	24 V	24 V
Total tolerance, static \pm	1 %	1 %
Static mains compensation, approx.	0.1 %	0.1 %
Static load compensation, approx.	0.1 %	0.1 %
Residual ripple, peak-peak, max.	50 mV	50 mV
Residual ripple, peak-peak, typ.		
Spikes peak-peak, max. (bandwidth approx. 20 MHz)	150 mV	150 mV
Product function: output voltage is adjustable	No	No
Status display	LED green for 24 V O.K.; LED red for fault; LED yellow for stand-by	LED green for 24 V O.K.; LED red for fault; LED yellow for stand-by
Signaling		
On/Off behavior	No overshoot of U_{out} (soft start)	No overshoot of U_{out} (soft start)
Startup delay, max.	1.5 s	1.5 s
Voltage rise, typ.	10 ms	10 ms
Rated current $I_{out \text{ rated}}$	3 A	8 A
Current range	0 ... 3 A	0 ... 8 A
typical active power output	72 W	192 W
short-term overload current in the event of a short circuit during startup, typical	12 A	35 A
Duration of the overload capability overcurrent in the event of a short circuit during startup	70 ms	70 ms
short-term overload current in the event of a short circuit during operation, typical	12 A	35 A
Duration of the overload capability overcurrent in the event of a short circuit during operation	70 ms	70 ms

Technical specifications (continued)

Order No.	6EP1 332-4BA00	6EP1 333-4BA00
Product	S7-1500 PM1507	S7-1500 PM1507
Power supply, type	24 V/3 A	24 V/8 A
Parallel switching for enhanced performance Note	Yes	Yes
	Parallel connection of 3 A and 8 A possible; devices must be activated simultaneously, at 1 load max. 75 % per device	Parallel connection of 3 A and 8 A possible; devices must be activated simultaneously, at 1 load max. 75 % per device
Number of devices that can be switched in parallel to increase performance, units	2	2
Efficiency		
Efficiency at $U_{out rated}$, $I_{out rated}$, approx.	87 %	90 %
Power loss at $U_{out rated}$, $I_{out rated}$, approx.	11 W	21 W
Closed-loop control		
Dynamic mains compensation ($U_{in rated} \pm 15 \%$), max.	0.1 %	0.1 %
Dynamic load compensation ($I_{out}: 50/100/50 \%$), $U_{out} \pm$ typ.	1 %	2 %
Setting time, maximum	5 ms	5 ms
Protection and monitoring		
Output overvoltage protection	additional control loop, differentiation (closed-loop control) at < 28.8 V	additional control loop, differentiation (closed-loop control) at < 28.8 V
Response value current limitation		
• minimum	3.15 A	8.4 A
• maximum	3.6 A	9.6 A
Current limitation, typ.	3.4 A	9 A
Property of the output, short-circuit-proof	Yes	Yes
Short-circuit protection	electronic shut-down, automatic restart	Electronic shut-down, automatic restart
Security		
Primary/secondary isolation	Yes	Yes
Electrical isolation	Safety extra-low output voltage U_{out} acc. to EN 60950-1 and EN 50178 and EN 61131-2	Safety extra-low output voltage U_{out} acc. to EN 60950-1 and EN 50178 and EN 61131-2
Protection class	Class I	Class I
Leakage current		
• maximum	3.5 mA	3.5 mA
• typical	0.4 mA	1.3 mA
CE marking	Yes	Yes
UL/cUL (CSA) approval	Available soon	Available soon
Explosion protection	Available soon	Available soon
CB approval	Yes	Yes
Degree of protection (EN 60529)	IP20	IP20

Order No.	6EP1 332-4BA00	6EP1 333-4BA00
Product	S7-1500 PM1507	S7-1500 PM1507
Power supply, type	24 V/3 A	24 V/8 A
EMC		
Emitted interference	EN 55022 Class B	EN 55022 Class B
Supply harmonics limitation	EN 61000-3-2	EN 61000-3-2
Noise immunity	EN 61000-6-2	EN 61000-6-2
Operating data		
Ambient temperature		
• during operation	0 ... 60 °C with natural convection	0 ... 60 °C with natural convection
- Note		
Ambient temperature		
• during transport	-40 ... +85 °C	-40 ... +85 °C
• during storage	-40 ... +85 °C	-40 ... +85 °C
Humidity class according to EN 60721	Climate class 3K3, without condensation	Climate class 3K3, without condensation
Mechanical system		
Connections	Screw/spring-type connection technology	Screw/spring-type connection technology
Connections		
• Supply input	L, N, PE: 1 screw terminal each for 0.5 ... 2.5 mm ²	L, N, PE: 1 screw terminal each for 0.5 ... 2.5 mm ²
• Output	L+, M: 2 screw terminals each for 0.5 ... 2.5 mm ²	L+, M: 2 screw terminals each for 0.5 ... 2.5 mm ²
• Auxiliary contacts		
Width of enclosure	50 mm	75 mm
Height of enclosure	147 mm	147 mm
Depth of enclosure	129 mm	129 mm
Mounting width	50 mm	75 mm
Mounting height	205 mm	205 mm
Weight, approx.	0.45 kg	0.74 kg
Product property of the enclosure: side-by-side enclosure	Yes	Yes
Type of mounting		
• Wall mounting	No	No
• DIN rail mounting	No	No
• S7-300 rail mounting	No	No
Installation	can be mounted onto S7-1500 rail	can be mounted onto S7-1500 rail

Ordering data

SIMATIC S7-1500 PM 1507

Input 120/230 V AC, output 24 V DC, 3 A

Input 120/230 V AC, output 24 V DC, 8 A

Order No.

6EP1 332-4BA00

6EP1 333-4BA00

SIMATIC S7-1500

SIPLUS power supplies

SIPLUS system power supplies

Overview



- System power supplies for the SIMATIC S7-1500
- For conversion of DC line voltages to the operating voltages required for the internal electronics
- Output power 25 W
- Can be used for S7-1500 or ET 200MP
- Configuration via STEP 7 V12

Note:

SIPLUS extreme products are based on Siemens Industry standard products. The contents listed here were taken from the respective standard products. SIPLUS extreme-specific information was added.

Technical specifications

The technical data correspond to those of the based-on modules apart from the values listed in the table:

based on	6AG1 505-0KA00-7AB0 6ES7 505-0KA00-0AB0
Ambient conditions	
Operating temperature	
• Horizontal mounting position	-25...+70 °C
• Vertical mounting position	-25...+50 °C
Extended ambient conditions	
• with reference to ambient temperature, air pressure and altitude	Tmin ... Tmax at 1080 hPa ... 795 hPa (-1000 m ... +2000 m) // Tmin ... (Tmax - 10K) at 795 hPa ... 658 hPa (+2000 m ... +3500 m) // Tmin ... (Tmax - 20K) at 658 hPa ... 540 hPa (+3500 m ... +5000 m)
Relative humidity	
• with condensation / maximum / tested in accordance with IEC 60068-2-38	100%; RH incl. condensation/frost (no commissioning in bedewed state)
Resistance	
• to biologically active substances / compliance with EN 60721-3-3	Yes; Class 3B2 mold and fungal spores (except fauna); the supplied plug covers must remain in place on the unused interfaces during operation.
• to chemically active substances / compliance with EN 60721-3-3	Yes; Class 3C4 (RH < 75%) incl. salt spray in accordance with EN 60068-2-52 (severity 3); the supplied plug covers must remain in place on the unused interfaces during operation.
• to mechanically active substances, compliance with EN 60721-3-3	Yes; Class 3S4 incl. sand, dust; the supplied plug covers must remain in place on unused interfaces during operation.

Ordering data

Order No.

SIPLUS system power supply

(extended temperature range and medial exposure)

For supplying the backplane bus of the S7-1500

24 V DC input voltage, power 25 W

6AG1 505-0KA00-7AB0

Accessories

See SIMATIC S7-1500, system power supplies, page 4/49

Overview Mounting rails



- Aluminum mounting rail for mounting the SIMATIC S7-1500 or ET 200MP
- With integrated DIN rail for snapping on a wide range of standard components
- Attachment of modules with a single screw
- Installation by screwing to the control cabinet wall
- Entire length of rail can be used

Ordering data

Order No.

SIMATIC S7-1500 mounting rail

Fixed lengths,
with grounding elements

- 160 mm
- 482 mm
- 530 mm
- 830 mm

For cutting to length by customer,
without drill holes; grounding ele-
ments must be ordered separately

- 2000 mm

6ES7 590-1AB60-0AA0
6ES7 590-1AE80-0AA0
6ES7 590-1AF30-0AA0
6ES7 590-1AJ30-0AA0

6ES7 590-1BC00-0AA0

PE connection element for mounting rail 2000 mm

20 units

6ES7 590-5AA00-0AA0

Overview Labeling sheets

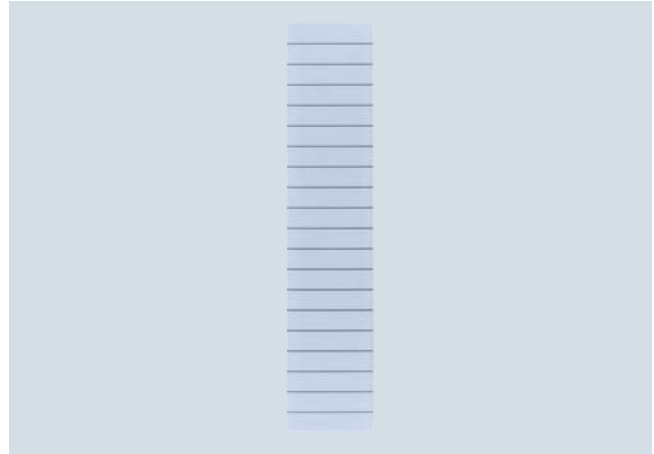

- Film sheets for the application-specific, automatic labeling of I/O modules of the SIMATIC S7-1500 using standard laser printers
- Printing direct from the TIA Portal possible
 - No double entry of symbols and/or addresses
 - Saves time and avoids typing errors
- Plain color films, tear-resistant, dirt-repellent
- Simple handling:
 - Perforated labeling sheets in DIN A4 format for easy separation of the labeling strips.
 - Detached strips can be inserted directly into the I/O modules.
- Different colors to differentiate module types; yellow reserved for failsafe systems

Ordering data

Order No.

DIN A4 labeling sheet

10 sheets with 10 labeling strips
each for I/O modules; perforated,
color Al grey

6ES7 592-2AX00-0AA0

SIMATIC S7-1500

Accessories

Spare parts

Overview

Front doors



- Versions:
 - Universal front doors for digital and analog I/O modules
 - Universal front doors for the interface module IM155-5 PN ST
- Included in the scope of delivery of the respective modules. Can be ordered as a spare part in a set consisting of five universal (unlabeled) front doors.
- Front doors for I/O modules: Universal labeling sheets and cabling diagrams are included. Cabling diagrams can be detached from perforated sheets and inserted inside the door.

U connector



- To interconnect the modules (self-assembling backplane bus)
- Implementation of a rugged, interference-free station setup through
 - consistent separation of supply voltage of modules and data signals
 - fully shielded, gold-plated contacts for the data bus
- Included in the scope of delivery of each module. Available as spare part in sets of 5.

Shielding



- Components for implementing the integrated shielding concept of the S7-1500:
 - 24 V DC infeed element for supplying the analog module: strict separation of infeed and analog signals ensures high EMC stability.
 - Shield clamp for insertion in the front connector: allows a low-impedance connection and optimally dissipates interference.
 - Universal shield terminal: connects the cable shield with the shield clamp and is simultaneously used for mechanical fixing.
- Included in the scope of delivery of the analog modules. Available as a spare part in two versions:
 - Shielding set, comprising infeed element, shield clamp, and shield terminal (pack of 5 units each)
 - Individual shield terminals (pack of 20)
- No tool required for assembly/disassembly

Ordering data	Order No.
Universal front door for IM 155-5 PN ST 5 front doors; spare part	6ES7 528-0AA70-7AA0
Universal front door for I/O modules 5 front doors; with 5 labeling strips (front) and 5 cabling diagrams per front door; spare part	6ES7 528-0AA00-7AA0
U connector 5 units; spare part	6ES7 590-0AA00-0AA0
Shielding set I/O Infeed element, shield clamp, and shield terminal; 5 units; spare part	6ES7 590-5CA00-0AA0
Shield terminal element 10 units; spare part	6ES7 590-5BA00-0AA0

SIMATIC S7-300



5/2	Introduction	5/153	SIPLUS function modules
5/4	Central processing units	5/153	SIPLUS FM 350-1 counter modules
5/4	Standard CPUs	5/154	SIPLUS FM 350-2 counter modules
5/14	SIPLUS standard CPUs	5/155	SIPLUS SIWAREX U
5/18	Compact CPUs	5/156	SIPLUS DCF 77 radio clock module
5/28	SIPLUS compact CPUs	5/157	Special modules
5/33	Fail-safe CPUs	5/157	SM 374 simulators
5/40	SIPLUS fail-safe CPUs	5/158	DM 370 dummy modules
5/44	Technology CPUs	5/159	Communication
5/49	Digital modules	5/159	CP 340
5/49	SM 321 digital input modules	5/161	CP 341
5/55	SM 322 digital output modules	5/163	Loadable drivers for CP 441-2 and CP 341
5/61	SM 323/SM 327 digital input/output modules	5/165	CP 343-2 P, CP 343-2
5/65	SIPLUS digital modules	5/167	CP 342-5
5/70	Analog modules	5/169	CP 342-5 FO
5/70	SM 331 analog input modules	5/171	CP 343-5
5/77	SM 332 analog output modules	5/173	CP 343-1 Lean
5/80	SM 334 analog input/output modules	5/176	CP 343-1
5/83	SIPLUS analog modules	5/179	CP 343-1 Advanced
5/88	F digital / analog modules	5/185	CP 343-1 ERPC
5/88	SM 326 F digital input modules - Safety Integrated	5/188	CSM 377 unmanaged
5/91	SM 326 F digital output modules - Safety Integrated	5/190	TIM 3V-IE for WAN and Ethernet
5/94	SM 336 F analog input modules - Safety Integrated	5/193	TIM 3V-IE Advanced
5/96	Isolation module	5/196	TIM 4R-IE for WAN and Ethernet
5/97	SIPLUS F digital / analog modules	5/199	TIM 3V-IE DNP3
5/100	Ex digital modules	5/201	TIM 4R-IE DNP3
5/100	Ex digital input modules	5/204	MD741-1 EGPRS router
5/102	Ex digital output modules	5/207	SCALANCE M87x UMTS routers
5/104	Ex analog modules	5/212	ASM 475
5/104	Ex analog input modules	5/214	SIPLUS communication
5/107	Ex analog output modules	5/223	Connection methods
5/109	Function modules	5/223	Front connectors
5/109	FM 350-1 counter modules	5/224	SIMATIC TOP connect for SIMATIC S7-300 and ET 200M
5/111	FM 350-2 counter modules	5/225	SIMATIC TOP connect for SIMATIC S7 Fully modular connection
5/113	FM 351 positioning modules	5/232	SIMATIC TOP connect for SIMATIC S7 Flexible connection
5/115	FM 352 cam controllers	5/233	Interface modules
5/117	FM 352-5 high-speed Boolean processor	5/234	SIPLUS interface modules
5/121	FM 353 positioning modules	5/235	Power supplies
5/123	FM 354 positioning modules	5/244	SIPLUS power supplies
5/125	FM 357-2 positioning modules	5/247	Accessories
5/127	FM 355 controller modules	5/247	Mounting rail
5/132	FM 355-2 temperature controller modules	5/248	Labeling sheets
5/137	SM 338 POS input modules	5/247	Accessories
5/139	IM 174 PROFIBUS modules	5/247	Mounting rail
5/141	SIWAREX U	5/248	Labeling sheets
5/144	SIWAREX FTA	Brochures	
5/147	SIWAREX FTC		For brochures serving as selection guides for SIMATIC products refer to:
5/150	SIFLOW FC070		www.siemens.com/simatic/printmaterial

SIMATIC S7-300

Introduction

S7-300/S7-300F

Overview



S7-300

- The modular mini PLC system for the low and mid-performance ranges
- With comprehensive range of modules for optimum adaptation to the automation task
- Flexible use through simple implementation of distributed structures and versatile networking
- User-friendly handling and uncomplicated design without a fan
- Can be expanded without problems when the tasks increase
- Powerful thanks to a range of integrated functions

S7-300F

- Failsafe automation system for plants with increased safety requirements for production technology
- Based on S7-300
- Additional ET 200S and ET 200M distributed I/O stations complete with safety-related modules can be connected
- Safety-related communication via PROFIBUS DP with PROFIsafe profile
- Standard modules can be used in addition for non-safety-relevant applications

SIPLUS S7-300

- The controller for use in the toughest environmental conditions
- Features an extended temperature range of -40/-25 °C to +60/70 °C
- Suitable for medial exposure (harmful gas atmosphere)
- Condensation and increased mechanical stress is permissible
- Features the proven PLC technology of the S7-300
- Easy to handle, program, maintain, and service
- Ideal for use in automotive engineering, environmental engineering, mining, chemical plants, material handling, food industry, etc.
- The replacement for expensive custom solutions

For further information, please go to:

www.siemens.com/siplus-extreme

For brochures serving as selection guides for SIMATIC products refer to:

www.siemens.com/simatic/printmaterial

Technical specifications

General technical data SIMATIC S7-300/S7-300F

Degree of protection	IP20 according to IEC 60 529
Ambient temperature	0 to 60 °C
<ul style="list-style-type: none"> • For horizontal installation • For vertical installation 	0 to 40 °C
Relative humidity	10 to 95%, without condensation, corresponds to relative humidity (RH), stress level 2 acc. to IEC 61131, Part 2)
Air pressure	From 1080 to 795 hPa (corresponds to an altitude of -1000 to +2000 m)
Insulation	500 V DC test voltage
• < 50 V	2500 V DC test voltage
• < 150 V	4000 V DC test voltage
• < 250 V	
Electromagnetic compatibility	Requirements of the EMC directive; interference immunity according to IEC 61000-6-2
<ul style="list-style-type: none"> • Pulse-shaped disturbance variables 	Test according to: Electrostatic discharge according to IEC 61000-4-2, burst pulses according to IEC 61000-4-4, energy single pulse (surge) according to IEC 61000-4-5,
<ul style="list-style-type: none"> • Sinusoidal disturbance variables 	Test according to: HF irradiation according to IEC 61000-4-3, HF decoupling according to IEC 61000-4-6
<ul style="list-style-type: none"> • Emission of radio interference 	Interference emission according to EN 50081-2 Test according to: Emitted interference of electromagnetic fields according to EN 55016: Limit value class A, (measured at a distance of 10 m) Interference emission via AC mains according to EN 55011: Limit value class A, Group 1
Mechanical strength	
<ul style="list-style-type: none"> • Vibrations 	Frequency range 10 Hz ≤ f ≤ 58 Hz <ul style="list-style-type: none"> • Continuous: 0.0375 mm amplitude • Occasionally 0.75 mm amplitude Frequency range 58 Hz ≤ f ≤ 150 Hz <ul style="list-style-type: none"> • Continuous: 0.5 g constant acceleration • Occasionally 1 g constant acceleration Testing according to IEC 60068-2-6 Tested with: <ul style="list-style-type: none"> 5 Hz ≤ f ≤ 9 Hz, constant amplitude 3.5 mm; 9 Hz ≤ f ≤ 150 Hz, constant acceleration 1 g; Duration of oscillation: 10 frequency passes per axis in each direction of the 3 mutually perpendicular axes Testing according to IEC 60068-2-27 Tested with: <ul style="list-style-type: none"> Half-sine wave: strength of shock 15 g peak value, 11 ms duration; Shock direction: 3 shocks each in ± direction in each of the 3 mutually vertical axes
<ul style="list-style-type: none"> • Shock 	

Technical specifications (continued)

General technical data SIPLUS S7-300	
Ambient temperature range	-40/-25 ... +60/70 °C
Conformal coating	Coating of the printed circuit boards and the electronic components
Technical data	The technical data of the standard product applies except for the environmental conditions.
Ambient conditions	
Relative humidity	5 ... 100%, condensation allowed
Biologically active substances	Conformity with EN 60721-3-3, Class 3B2 mold and fungal spores (except fauna)
Chemically active substances	Conformity with EN 60721-3-3, Class 3C4 incl. salt mist and ISA-S71,04 severity level G1; G2; G3; GX ¹⁾²⁾
Mechanically active substances	Conformity with EN 60721-3-3, Class 3S4 including conductive sand, dust ²⁾
Air pressure (depending on the highest positive temperature range specified)	1080 ... 795 hPa (-1000 ... +2000 m) see ambient temperature range 795 ... 658 hPa (+2000 ... 3500 m) derating 10 K 658 ... 540 hPa (+3500 ... +5000 m) derating 20 K
Compliant with the standard for electronic equipment used on railway rolling stock (EN 50155, temperature T1, category 1)	Yes

SIMATIC S7-300

Central processing units

Standard CPUs

Overview CPU 312



- The entry level CPU in Totally Integrated Automation (TIA)
- For smaller applications with moderate processing performance requirements

SIMATIC Micro Memory Card required for operation of the CPU.

Overview CPU 314



- For plants with medium program scope requirements
- High processing power in binary and floating-point arithmetic

SIMATIC Micro Memory Card required for operation of CPU.

Overview CPU 315-2 DP



- The CPU with medium to large program memory and quantity structures for optional use of SIMATIC engineering tools
- High processing power in binary and floating-point arithmetic
- Used as central controller in production lines with central and distributed I/O
- PROFIBUS DP master/slave interface
- For comprehensive I/O expansion
- For configuring distributed I/O structures
- Isochronous mode on PROFIBUS

SIMATIC Micro Memory Card required for operation of CPU.

SIMATIC S7-300

Central processing units

Standard CPUs

Overview CPU 315-2 PN/DP



- The CPU with mid-range program memory and quantity frameworks
- High processing power in binary and floating-point arithmetic
- Used as central controller in production lines with central and distributed I/O
- PROFINET interface with 2-port switch
- PROFINET IO Controller for operating distributed I/O on PROFINET
- PROFINET I-Device for connecting the CPU as intelligent PROFINET device under a SIMATIC or third-party PROFINET I/O Controller
- Component Based Automation (CBA) on PROFINET
- PROFINET proxy for intelligent devices on PROFIBUS DP in Component Based Automation (CBA)
- Integrated web server with the option of creating user-defined web pages
- Combined MPI/PROFIBUS DP master/slave interface
- Isochronous mode on PROFIBUS and PROFINET

SIMATIC Micro Memory Card required for operation of CPU.

Overview CPU 317-2 DP



- The CPU with a large program memory and quantity framework for demanding applications
- For cross-industry automation tasks in series machine, special machine and plant construction
- Used as central controller in production lines with central and distributed I/O
- High processing power in binary and floating-point arithmetic
- 2 PROFIBUS DP master/slave interfaces
- For comprehensive I/O expansion
- For configuring distributed I/O structures
- Isochronous mode on PROFIBUS
- Optionally supports the use of SIMATIC engineering tools

SIMATIC Micro Memory Card required for operation of CPU.

SIMATIC S7-300

Central processing units

Standard CPUs

Overview CPU 317-2 PN/DP



- The CPU with a large program memory and quantity framework for demanding applications
- For cross-industry automation tasks in series machine, special machine and plant construction
- Used as central controller in production lines with central and distributed I/O
- High processing power in binary and floating-point arithmetic
- PROFINET interface with 2-port switch
- PROFINET I/O Controller for operating distributed I/O on PROFINET
- PROFINET I-Device for connecting the CPU as intelligent PROFINET device under a SIMATIC or third-party PROFINET I/O Controller
- Distributed intelligence in Component Based Automation (CBA) on PROFINET
- PROFINET proxy for intelligent devices on PROFIBUS DP in Component Based Automation (CBA)
- Integrated web server with the option of creating user-defined web pages
- Combined MPI/PROFIBUS DP master/slave interface
- Isochronous mode on PROFIBUS and PROFINET
- Optionally supports the use of SIMATIC engineering tools

SIMATIC Micro Memory Card required for operation of CPU.

Overview CPU 319-3 PN/DP



- The CPU with high command processing performance, large program memory and quantity framework for demanding applications
- For cross-industry automation tasks in series machine, special machine and plant construction
- Used as central controller in production lines with central and distributed I/O on PROFIBUS and PROFINET
- PROFINET I/O controller for operating distributed I/O on PROFINET
- PROFINET I-Device for connecting the CPU as an intelligent PROFINET device under a SIMATIC or non-Siemens PROFINET I/O controller
- PROFINET interface with 2-port switch
- Isochronous mode on PROFIBUS or PROFINET
- Integrated web server with the option of creating user-defined web pages
- Distributed intelligence in Component Based Automation (CBA) on PROFINET
- PROFINET proxy for intelligent devices on PROFIBUS DP in Component Based Automation (CBA)
- Optionally supports the use of SIMATIC engineering tools

SIMATIC Micro Memory Card required for operation of the CPU.

Technical specifications

	6ES7 312-1AE14-0AB0	6ES7 314-1AG14-0AB0	6ES7 315-2AH14-0AB0	6ES7 315-2EH14-0AB0
General information				
Engineering with				
• Programming package	STEP 7 V5.5 + SP1 or higher or STEP7 V5.2 + SP1 or higher with HSP 218	STEP 7 V5.5 + SP1 or higher or STEP7 V5.2 + SP1 or higher with HSP 218	STEP 7 V5.5 + SP1 or higher or STEP7 V5.2 + SP1 or higher with HSP 218	STEP7 V 5.5 or higher
Supply voltage				
24 V DC	Yes	Yes	Yes	Yes
Power losses				
Power loss, typ.	4 W	4 W	4.5 W	4.65 W
Memory				
Work memory				
• integrated	32 kbyte	128 kbyte	256 kbyte	384 kbyte
• Size of retentive memory for retentive data blocks	32 kbyte	64 kbyte	128 kbyte	128 kbyte
Load memory				
• pluggable (MMC), max.	8 Mbyte	8 Mbyte	8 Mbyte	8 Mbyte
CPU processing times				
for bit operations, typ.	0.1 µs	0.06 µs	0.05 µs	0.05 µs
for word operations, typ.	0.24 µs	0.12 µs	0.09 µs	0.09 µs
for fixed point arithmetic, typ.	0.32 µs	0.16 µs	0.12 µs	0.12 µs
for floating point arithmetic, typ.	1.1 µs	0.59 µs	0.45 µs	0.45 µs
Counters, timers and their retentivity				
S7 counter				
• Number	256	256	256	256
IEC counter				
• present	Yes	Yes	Yes	Yes
S7 times				
• Number	256	256	256	256
IEC timer				
• present	Yes	Yes	Yes	Yes
Data areas and their retentivity				
Flag				
• Number, max.	256 byte	256 byte	2 048 byte	2 048 byte
Address area				
I/O address area				
• Inputs	1 024 byte	1 024 byte	2 048 byte	2 048 byte
• Outputs	1 024 byte	1 024 byte	2 048 byte	2 048 byte
Process image				
• Inputs, adjustable	1 024 byte	1 024 byte	2 048 byte	2 048 byte
• Outputs, adjustable	1 024 byte	1 024 byte	2 048 byte	2 048 byte
Time of day				
Clock				
• Hardware clock (real-time clock)		Yes	Yes	Yes
Operating hours counter				
• Number	1	1	1	1
1st interface				
Type of interface	Integrated RS 485 interface	Integrated RS 485 interface	Integrated RS 485 interface	Integrated RS 485 interface
Physics	RS 485	RS 485	RS 485	RS 485
Functionality				
• MPI	Yes	Yes	Yes	Yes
• DP master	No	No	No	Yes
• DP slave	No	No	No	Yes
• Point-to-point connection	No	No	No	No
DP master				
• Number of DP slaves, max.				124

SIMATIC S7-300

Central processing units

Standard CPUs

Technical specifications (continued)

	6ES7 312-1AE14-0AB0	6ES7 314-1AG14-0AB0	6ES7 315-2AH14-0AB0	6ES7 315-2EH14-0AB0
2nd interface				
Type of interface			Integrated RS 485 interface	PROFINET
Physics			RS 485	Ethernet RJ45
Number of ports				2
Functionality				
• MPI			No	No
• DP master			Yes	No
• DP slave			Yes	No
• PROFINET IO Controller				Yes; Also simultaneously with IO-Device functionality
• PROFINET IO Device				Yes; Also simultaneously with IO Controller functionality
• PROFINET CBA				Yes
DP master				
• Number of DP slaves, max.			124; Per station	
PROFINET IO Controller				
• Max. number of connectable IO devices for RT				128
• Number of IO devices with IRT and the option "high flexibility"				128
• Number of IO Devices with IRT and the option "high performance", max.				64
Isochronous mode				
Isochronous operation (application synchronized up to terminal)			Yes	Yes; Via PROFIBUS DP or PROFINET interface
Communication functions				
PG/OP communication	Yes	Yes	Yes	Yes
Data record routing	No	No	Yes	Yes
Global data communication				
• supported	Yes	Yes	Yes	Yes
S7 basic communication				
• supported	Yes	Yes	Yes	Yes
S7 communication				
• supported	Yes	Yes	Yes	Yes
S5-compatible communication				
• supported	Yes; via CP and loadable FC	Yes; via CP and loadable FC	Yes; via CP and loadable FC	Yes; via CP and loadable FC
Open IE communication				
• TCP/IP				Yes; via integrated PROFINET interface and loadable FBs
- Number of connections, max.				8
• ISO-on-TCP (RFC1006)				Yes; via integrated PROFINET interface and loadable FBs
- Number of connections, max.				8
• UDP				Yes; via integrated PROFINET interface and loadable FBs
- Number of connections, max.				8
Web server				
• supported				Yes
Number of connections				
• overall	6	12	16	16
Ambient conditions				
Operating temperature				
• Min.	0 °C	0 °C	0 °C	0 °C
• max.	60 °C	60 °C	60 °C	60 °C

Technical specifications (continued)

	6ES7 312-1AE14-0AB0	6ES7 314-1AG14-0AB0	6ES7 315-2AH14-0AB0	6ES7 315-2EH14-0AB0
Configuration				
programming				
• Programming language				
- LAD	Yes	Yes	Yes	Yes
- FBD	Yes	Yes	Yes	Yes
- STL	Yes	Yes	Yes	Yes
- SCL	Yes	Yes	Yes	Yes
- CFC	Yes	Yes	Yes	Yes
- GRAPH	Yes	Yes	Yes	Yes
- HiGraph®	Yes	Yes	Yes	Yes
Know-how protection				
• User program protection/ password protection	Yes	Yes	Yes	Yes
• Block encryption	Yes; With S7 block Privacy	Yes; With S7 block Privacy	Yes; With S7 block Privacy	Yes; With S7 block Privacy
Dimensions				
Width	40 mm	40 mm	40 mm	40 mm
Height	125 mm	125 mm	125 mm	125 mm
Depth	130 mm	130 mm	130 mm	130 mm
Weight				
Weight, approx.	270 g	280 g	290 g	340 g
	6ES7 317-2AK14-0AB0	6ES7 317-2EK14-0AB0	6ES7 318-3EL01-0AB0	
General information				
Engineering with				
• Programming package	STEP7 as of V5.5 + SP1 or STEP 7 V5.2 + SP1 or higher with HSP 202	STEP7 V 5.5 or higher	STEP7 V 5.5 or higher	
Supply voltage				
24 V DC	Yes	Yes	Yes	
Power losses				
Power loss, typ.	4.5 W	4.65 W	14 W	
Memory				
Work memory				
• integrated	1 024 kbyte	1 024 kbyte	2 048 kbyte	
• Size of retentive memory for retentive data blocks	256 kbyte	256 kbyte	700 kbyte	
Load memory				
• pluggable (MMC), max.	8 Mbyte	8 Mbyte	8 Mbyte	
CPU processing times				
for bit operations, typ.	0.025 µs	0.025 µs	0.004 µs	
for word operations, typ.	0.03 µs	0.03 µs	0.01 µs	
for fixed point arithmetic, typ.	0.04 µs	0.04 µs	0.01 µs	
for floating point arithmetic, typ.	0.16 µs	0.16 µs	0.04 µs	
Counters, timers and their retentivity				
S7 counter				
• Number	512	512	2 048	
IEC counter				
• present	Yes	Yes	Yes	
S7 times				
• Number	512	512	2 048	
IEC timer				
• present	Yes	Yes	Yes	
Data areas and their retentivity				
Flag				
• Number, max.	4 096 byte	4 096 byte	8 192 byte	

SIMATIC S7-300

Central processing units

Standard CPUs

Technical specifications (continued)

	6ES7 317-2AK14-0AB0	6ES7 317-2EK14-0AB0	6ES7 318-3EL01-0AB0
Address area			
I/O address area			
• Inputs	8 192 byte	8 192 byte	8 192 byte
• Outputs	8 192 byte	8 192 byte	8 192 byte
Process image			
• Inputs, adjustable	8 192 byte	8 192 byte	8 192 byte
• Outputs, adjustable	8 192 byte	8 192 byte	8 192 byte
Time of day			
Clock			
• Hardware clock (real-time clock)	Yes	Yes	Yes
Operating hours counter			
• Number	4	4	4
1st interface			
Type of interface	Integrated RS 485 interface	Integrated RS 485 interface	Integrated RS 485 interface
Physics	RS 485	RS 485	RS 485
Functionality			
• MPI	Yes	Yes	Yes
• DP master	Yes	Yes	Yes
• DP slave	Yes; A DP slave at both interfaces simultaneously is not possible	Yes	Yes; A DP slave at both interfaces simultaneously is not possible
• Point-to-point connection	No	No	No
DP master			
• Number of DP slaves, max.	124	124	124
2nd interface			
Type of interface	Integrated RS 485 interface	PROFINET	Integrated RS 485 interface
Physics	RS 485	Ethernet RJ45	RS 485
Number of ports			
		2	
Functionality			
• MPI	No	No	No
• DP master	Yes	No	Yes
• DP slave	Yes; A DP slave at both interfaces simultaneously is not possible	No	Yes; A DP slave at both interfaces simultaneously is not possible
• PROFINET IO Controller		Yes; Also simultaneously with IO-Device functionality	No
• PROFINET IO Device		Yes; Also simultaneously with IO Controller functionality	No
• PROFINET CBA		Yes	No
DP master			
• Number of DP slaves, max.	124		124
PROFINET IO Controller			
• Max. number of connectable IO devices for RT		128	
• Number of IO devices with IRT and the option "high flexibility"		128	
• Number of IO Devices with IRT and the option "high performance", max.		64	
3rd interface			
Type of interface			PROFINET
Physics			Ethernet RJ45
Number of ports			
			2
Functionality			
• MPI			No
• DP master			No
• DP slave			No
• PROFINET IO Controller			Yes; Also simultaneously with I-Device functionality
• PROFINET IO Device			Yes; Also simultaneously with IO Controller functionality
• PROFINET CBA			Yes

Technical specifications (continued)

	6ES7 317-2AK14-0AB0	6ES7 317-2EK14-0AB0	6ES7 318-3EL01-0AB0
PROFINET IO Controller			
• Max. number of connectable IO devices for RT			256
• Number of IO devices with IRT and the option "high flexibility"			256
• Number of IO Devices with IRT and the option "high performance", max.			64
Isochronous mode			
Isochronous operation (application synchronized up to terminal)		Yes; Via PROFIBUS DP or PROFINET interface	Yes; Via 2nd PROFIBUS DP or PROFINET interface
Communication functions			
PG/OP communication	Yes	Yes	Yes
Data record routing	Yes	Yes	Yes
Global data communication			
• supported	Yes	Yes	Yes
S7 basic communication			
• supported	Yes	Yes	Yes
S7 communication			
• supported	Yes	Yes	Yes
S5-compatible communication			
• supported	Yes; via CP and loadable FC	Yes; via CP and loadable FC	Yes; via CP and loadable FC
Open IE communication			
• TCP/IP		Yes; via integrated PROFINET interface and loadable FBs	Yes; via integrated PROFINET interface and loadable FBs
- Number of connections, max.		16	32
• ISO-on-TCP (RFC1006)		Yes; via integrated PROFINET interface and loadable FBs	Yes; via integrated PROFINET interface and loadable FBs
- Number of connections, max.		16	32
• UDP		Yes; via integrated PROFINET interface and loadable FBs	Yes; via integrated PROFINET interface and loadable FBs
- Number of connections, max.		16	32
Web server			
• supported		Yes	Yes
Number of connections			
• overall	32	32	32
Ambient conditions			
Operating temperature			
• Min.	0 °C	0 °C	0 °C
• max.	60 °C	60 °C	60 °C
Configuration			
programming			
• Programming language			
- LAD	Yes	Yes	Yes
- FBD	Yes	Yes	Yes
- STL	Yes	Yes	Yes
- SCL	Yes	Yes	Yes
- CFC	Yes	Yes	Yes
- GRAPH	Yes	Yes	Yes
- HiGraph®	Yes	Yes	Yes
Know-how protection			
• User program protection/ password protection	Yes	Yes	Yes
• Block encryption	Yes; With S7 block Privacy	Yes; With S7 block Privacy	Yes; With S7 block Privacy
Dimensions			
Width	40 mm	40 mm	120 mm
Height	125 mm	125 mm	125 mm
Depth	130 mm	130 mm	130 mm
Weight			
Weight, approx.	360 g	340 g	1 250 g

SIMATIC S7-300

Central processing units

Standard CPUs

5

Ordering data	Order No.	Order No.
CPU 312 32 KB main memory, 24 V DC power supply, MPI; MMC required	6ES7 312-1AE14-0AB0	SIMATIC Manual Collection Electronic manuals on DVD, multilingual: LOGO!, SIMADYN, SIMATIC bus components, SIMATIC C7, SIMATIC distributed I/O, SIMATIC HMI, SIMATIC Sensors, SIMATIC NET, SIMATIC PC Based Automation, SIMATIC PCS 7, SIMATIC PG/PC, SIMATIC S7, SIMATIC Software, SIMATIC TDC
CPU 314 128 KB main memory, 24 V DC power supply, MPI; MMC required	6ES7 314-1AG14-0AB0	SIMATIC Manual Collection update service for 1 year Current "Manual Collection" DVD and the three subsequent updates
CPU 315-2 DP 256 KB main memory, 24 V DC power supply, MPI, PROFIBUS DP master/slave interface, MMC required	6ES7 315-2AH14-0AB0	Power supply connector 10 units, spare part
CPU 315-2 PN/DP 384 KB main memory, 24 V DC power supply, combined MPI/PROFIBUS DP master/slave interface, Ethernet/PROFINET interface with 2-port switch; MMC required	6ES7 315-2EH14-0AB0	SIMATIC S7 training case With mounting components for mounting S7-200 and S7-300
CPU 317-2 DP Main memory 1 MB, power supply 24 V DC, MPI, PROFIBUS DP master/slave interface, MMC required	6ES7 317-2AK14-0AB0	PC adapter USB A2 For connecting a PG/PC or notebook to PROFIBUS or MPI, USB cable included in scope of supply
CPU 317-2 PN/DP 1 MB main memory, 24 V DC power supply, combined MPI/PROFIBUS DP master/slave interface, Ethernet/PROFINET interface with 2-port switch; MMC required	6ES7 317-2EK14-0AB0	PROFIBUS bus components
CPU 319-3 PN/DP 1.4 MB main memory, 24 V DC power supply, combined MPI/PROFIBUS DP master/slave interface, Ethernet/PROFINET interface with 2-port switch; MMC required	6ES7 318-3EL01-0AB0	PROFIBUS DP bus connector RS 485 <ul style="list-style-type: none"> With 90° cable outlet, max. transfer rate 12 Mbit/s <ul style="list-style-type: none"> Without PG interface With PG interface With 90° cable outlet for FastConnect connection system, max. transfer rate 12 Mbit/s <ul style="list-style-type: none"> Without PG interface, 1 unit Without PG interface, 100 units With PG interface, 1 unit With PG interface, 100 units With axial cable outlet for SIMATIC OP, for connecting to PPI, MPI, PROFIBUS
SIMATIC Micro Memory Card		
64 KB	6ES7 953-8LF20-0AA0	6ES7 972-0BA12-0XA0 6ES7 972-0BB12-0XA0
128 KB	6ES7 953-8LG20-0AA0	
512 KB	6ES7 953-8LJ30-0AA0	6ES7 972-0BA52-0XA0 6ES7 972-0BA52-0XB0 6ES7 972-0BB52-0XA0 6ES7 972-0BB52-0XB0 6GK1 500-0EA02
2 MB	6ES7 953-8LL31-0AA0	
4 MB	6ES7 953-8LM20-0AA0	
8 MB	6ES7 953-8LP20-0AA0	
MPI cable for connection of SIMATIC S7 and PG via MPI; 5 m in length	6ES7 901-0BF00-0AA0	PROFIBUS Fast Connect bus cable Standard type with special design for quick mounting, 2-core, shielded, sold by the meter, max. delivery unit 1000 m, minimum ordering quantity 20 m
Slot number plates	6ES7 912-0AA00-0AA0	RS 485 repeater for PROFIBUS Transmission rate up to 12 Mbit/s; 24 V DC; IP20 enclosure
S7-300 manual Design, CPU data, module data, instruction list		
German	6ES7 398-8FA10-8AA0	
English	6ES7 398-8FA10-8BA0	

SIMATIC S7-300

Central processing units

Standard CPUs

Ordering data	Order No.	Order No.	
PROFINET bus components			
IE FC TP Standard Cable GP 2x2 4-core, shielded TP installation cable for connection to IE FC Outlet RJ45/ IE FC RJ45 Plug; PROFINET-compatible; with UL approval; sold by the meter	6XV1 840-2AH10		
FO Standard Cable GP (50/125) Standard cable, splittable, UL approval, sold by the meter	6XV1 873-2A		
SCALANCE X204-2 Industrial Ethernet Switch Industrial Ethernet switches with integral SNMP access, Web diagnostics, copper cable diagnostics and PROFINET diagnostics for configuring line, star and ring topologies; four 10/100 Mbit/s RJ45 ports and two FO ports	6GK5 204-2BB10-2AA3		
Compact Switch Module CSM 377 Unmanaged switch for connecting a SIMATIC S7-300, ET200 M and up to three other stations to Industrial Ethernet with 10/100 Mbit/s; 4 x RJ45 ports; external 24 V DC power supply, LED diagnostics, S7-300 module incl. electronic manual on CD-ROM	6GK7 377-1AA00-0AA0		
		IE FC RJ45 Plugs RJ45 plug connector for Industrial Ethernet with a rugged metal enclosure and integrated insulation displacement contacts for connecting Industrial Ethernet FC installation cables	
		IE FC RJ45 Plug 145 145° cable outlet 1 unit 10 units 50 units	6GK1 901-1BB30-0AA0 6GK1 901-1BB30-0AB0 6GK1 901-1BB30-0AE0
		IE FC RJ45 Plug 180 180° cable outlet 1 unit 10 units 50 units	6GK1 901-1BB10-2AA0 6GK1 901-1BB10-2AB0 6GK1 901-1BB10-2AE0
		PROFIBUS/PROFINET bus components For establishing MPI/PROFIBUS/PROFINET communication	See catalogs IK PI, CA 01

5

SIMATIC S7-300

Central processing units

SIPLUS standard CPUs

Overview SIPLUS CPU 314



- For plants with medium requirements on the program scope
- High processing performance in binary and floating-point arithmetic

SIPLUS Micro Memory Card required for operation of CPU.

Note:

SIPLUS extreme products are based on Siemens Industry standard products. The contents listed here were taken from the respective standard products. SIPLUS extreme-specific information was added.

SIPLUS CPU 314	6AG1 314-1AG14-2AY0	6AG1 314-1AG14-7AB0
Order No.	6AG1 314-1AG14-2AY0	6AG1 314-1AG14-7AB0
Order number based on	6ES7 314-1AG14-0AB0	6ES7 314-1AG14-0AB0
Ambient temperature range	-25 ... +60 °C	-25 ... +70 °C
Conformal coating	Coating of the printed circuit boards and the electronic components	
Technical data	The technical data of the standard product applies except for the ambient conditions	
Compliant with the standards for electronic equipment used on rolling stock (EN 50155, temperature T1, category 1).	Yes	No

Ambient conditions

Relative humidity	100%, condensation/frost permissible. No commissioning if condensation present.
Biologically active substances, compliance with EN 60721-3-3	Class 3B2 mold and fungal spores (excluding fauna). The supplied plug covers must remain in place over the unused interfaces during operation!
Chemically active substances, compliance with EN 60721-3-3	Class 3C4 incl. salt spray in accordance with EN 60068-2-52 (degree of severity 3). The supplied plug covers must remain in place over the unused interfaces during operation!
Mechanically active substances, compliance with EN 60721-3-3	Class 3S4 incl. sand, dust. The supplied plug covers must remain in place over the unused interfaces during operation!
Air pressure (depending on the highest positive temperature range specified)	1080 ... 795 hPa (-1000 ... +2000 m) see ambient temperature range 795 ... 658 hPa (+2000 ... +3500 m) derating 10 K 658 ... 540 hPa (+3500 ... +5000 m) derating 20 K

The technical documentation on SIPLUS can be found here:
www.siemens.com/siplus-extreme

Ordering data	Order No.
SIPLUS CPU 314	
(extended temperature range and medial exposure)	
Main memory 128 KB, power supply 24 V DC, MPI; MMC required	6AG1 314-1AG14-7AB0
Additional conformance with EN 50155	6AG1 314-1AG14-2AY0
Accessories	See SIMATIC CPU 314, page 5/12

SIMATIC S7-300

Central processing units

SIPLUS Standard CPUs
Overview SIPLUS CPU 315-2 DP

- The CPU with medium to large program memory and quantity structures for optional use of SIMATIC engineering tools
- High processing performance in binary and floating-point arithmetic
- PROFIBUS DP master/slave interface
- For comprehensive I/O expansion
- For configuring distributed I/O structures

SIMATIC Micro Memory Card required for operation of the CPU.

Note:

SIPLUS extreme products are based on Siemens Industry standard products. The contents listed here were taken from the respective standard products. SIPLUS extreme-specific information was added.

SIPLUS CPU 315-2 DP	6AG1 315-2AH14-2AY0	6AG1 315-2AH14-7AB0
Order No.	6AG1 315-2AH14-2AY0	6AG1 315-2AH14-7AB0
Order number based on	6ES7 315-2AH14-0AB0	6ES7 315-2AH14-0AB0
Ambient temperature range	-25 ... +60 °C	-25 ... +70 °C
Conformal coating	Coating of the printed circuit boards and the electronic components	
Technical data	The technical data of the standard product applies except for the ambient conditions	
Compliant with the standards for electronic equipment used on rolling stock (EN 50155, temperature T1, category 1).	Yes	No

Ambient conditions

Relative humidity	100%, condensation/frost permissible. No commissioning if condensation present.	
Biologically active substances, compliance with EN 60721-3-3	Class 3B2 mold and fungal spores (excluding fauna). The supplied plug covers must remain in place over the unused interfaces during operation!	
Chemically active substances, compliance with EN 60721-3-3	Class 3C4 incl. salt spray in accordance with EN 60068-2-52 (degree of severity 3). The supplied plug covers must remain in place over the unused interfaces during operation!	
Mechanically active substances, compliance with EN 60721-3-3	Class 3S4 incl. sand, dust. The supplied plug covers must remain in place over the unused interfaces during operation!	
Air pressure (depending on the highest positive temperature range specified)	1080 ... 795 hPa (-1000 ... +2000 m) see ambient temperature range 795 ... 658 hPa (+2000 ... +3500 m) derating 10 K 658 ... 540 hPa (+3500 ... +5000 m) derating 20 K	

 The technical documentation on SIPLUS can be found here:
www.siemens.com/siplus-extreme
Ordering data
Order No.
SIPLUS CPU 315-2 DP

(extended temperature range and medial exposure)

Work memory 256 KB, power supply 24 V DC, MPI, PROFIBUS DP master/slave interface, MMC required

Additional conformance with EN 50155

Accessories

See SIMATIC CPU 315-2 DP, page 5/12

6AG1 315-2AH14-7AB0
6AG1 315-2AH14-2AY0

SIMATIC S7-300

Central processing units

SIPLUS Standard CPUs

Overview SIPLUS CPU 315-2 PN/DP



- The CPU with medium-sized program memory and quantity frameworks
- High processing performance in binary and floating-point arithmetic
- Used as central controller in production lines with central and distributed I/O
- Component Based Automation (CBA) on PROFINET
- PROFINET proxy for intelligent devices on PROFIBUS DP in Component Based Automation (CBA)
- PROFINET IO Controller for operating distributed I/O on PROFINET
- PROFINET interface with 2-port switch
- Combined MPI/PROFIBUS DP master/slave interface
- Isochronous mode on PROFIBUS

SIMATIC Micro Memory Card required for operation of CPU.

Note:

SIPLUS extreme products are based on Siemens Industry standard products. The contents listed here were taken from the respective standard products. SIPLUS extreme-specific information was added.

SIPLUS CPU 315-2 PN/DP		
Order No.	6AG1 315-2EH14-2AY0	6AG1 315-2EH14-7AB0
Order number based on	6ES7 315-2EH14-0AB0	6ES7 315-2EH14-0AB0
Ambient temperature range	-25 ... +60 °C	-25 ... +70 °C
Conformal coating	Coating of the printed circuit boards and the electronic components	
Technical data	The technical data of the standard product applies except for the ambient conditions	
Compliant with the standards for electronic equipment used on rolling stock (EN 50155, temperature T1, category 1).	Yes	No
Ambient conditions		
Relative humidity	100%, condensation/frost permissible. No commissioning if condensation present.	
Biologically active substances, compliance with EN 60721-3-3	Class 3B2 mold and fungal spores (excluding fauna). The supplied plug covers must remain in place over the unused interfaces during operation!	
Chemically active substances, compliance with EN 60721-3-3	Class 3C4 incl. salt spray in accordance with EN 60068-2-52 (degree of severity 3). The supplied plug covers must remain in place over the unused interfaces during operation!	
Mechanically active substances, compliance with EN 60721-3-3	Class 3S4 incl. sand, dust. The supplied plug covers must remain in place over the unused interfaces during operation!	
Air pressure (depending on the highest positive temperature range specified)	1080 ... 795 hPa (-1000 ... +2000 m) see ambient temperature range 795 ... 658 hPa (+2000 ... +3500 m) derating 10 K 658 ... 540 hPa (+3500 ... +5000 m) derating 20 K	

The technical documentation on SIPLUS can be found here:
www.siemens.com/siplus-extreme

Ordering data

Order No.

SIPLUS CPU 315-2 PN/DP

(extended temperature range and medial exposure)

Work memory 384 KB, power supply 24 V DC, combined MPI/PROFIBUS DP master/slave interface, Ethernet/PROFINET interface with 2-port switch; MMC required

6AG1 315-2EH14-7AB0

Additional conformance with EN 50155

6AG1 315-2EH14-2AY0

Accessories

See SIMATIC CPU 315-2 PN/DP, page 5/12

Overview SIPLUS CPU 317-2 PN/DP



- The CPU with a large program memory and quantity framework for demanding applications
- Distributed intelligence in Component Based Automation (CBA) on PROFINET
- PROFINET proxy for intelligent devices on PROFIBUS DP in Component Based Automation (CBA)
- PROFINET I/O Controller for operating distributed I/O on PROFINET
- For cross-industry automation tasks in series machine, special machine and plant construction
- Used as central controller in production lines with central and distributed I/O
- For comprehensive I/O expansion
- For configuring distributed I/O structures
- High processing performance in binary and floating-point arithmetic
- Combined MPI/PROFIBUS DP master/slave interface
- Optionally supports the use of SIMATIC engineering tools

Micro Memory Card required for operation of CPU.

Note:

SIPLUS extreme products are based on Siemens Industry standard products. The contents listed here were taken from the respective standard products. SIPLUS extreme-specific information was added.

SIPLUS CPU 317-2 PN/DP		
Order number	6AG1 317-2EK14-7AB0	6AG1 317-2EK14-2AY0
Order number based on	6ES7 317-2EK14-0AB0	6ES7 317-2EK14-0AB0
Ambient temperature range	-25 ... +70 °C	
Conforms with standard for electronic equipment used on rolling stock (EN 50155)	No	Yes
Conformal coating	Coating of the printed circuit boards and the electronic components	
Technical data	The technical data of the standard product applies except for the ambient conditions.	
Ambient conditions		
Relative humidity	100%, condensation/frost permissible. No commissioning if condensation present.	
Biologically active substances, compliance with EN 60721-3-3	Class 3B2 mold and fungal spores (excluding fauna). The supplied plug covers must remain in place over the unused interfaces during operation!	
Chemically active substances, compliance with EN 60721-3-3	Class 3C4 incl. salt spray in accordance with EN 60068-2-52 (degree of severity 3). The supplied plug covers must remain in place over the unused interfaces during operation!	
Mechanically active substances, compliance with EN 60721-3-3	Class 3S4 incl. sand, dust. The supplied plug covers must remain in place over the unused interfaces during operation!	
Air pressure (depending on the highest positive temperature range specified)	1080 ... 795 hPa (-1000 ... +2000 m) see ambient temperature range 795 ... 658 hPa (+2000 ... +3500 m) derating 10 K 658 ... 540 hPa (+3500 ... +5000 m) derating 20 K	

For technical documentation on SIPLUS, see:
www.siemens.com/siplus-extreme

Ordering data

Order No.

SIPLUS CPU 317-2 PN/DP

(extended temperature range and medial exposure)

Main memory 1 MB, power supply 24 V DC, combined MPI/PROFIBUS DP master/slave interface, Ethernet/PROFINET interface;
MMC required

Additional conformance with EN 50155

6AG1 317-2EK14-7AB0

6AG1 317-2EK14-2AY0

Accessories

See SIMATIC CPU 317-2 PN/DP, page 5/12

SIMATIC S7-300

Central processing units

Compact CPUs

Overview CPU 312C



- The compact CPU with integral digital inputs/outputs
- For small applications with increased processing performance requirements
- With technological functions

SIMATIC Micro Memory Card required for operation of CPU.

Overview CPU 313C-2 PtP



- The compact CPU with integrated digital inputs/outputs as well as second serial interface
- For plants with high processing performance and response time requirements
- With technological functions

SIMATIC Micro Memory Card required for operation of the CPU.

Overview CPU 313C



- The compact CPU with integral digital and analog inputs/outputs
- For plants with high processing performance and response time requirements
- With technological functions

SIMATIC Micro Memory Card required for operation of the CPU.

Overview CPU 313C-2 DP



- The compact CPU with integral digital inputs/outputs and PROFIBUS DP master/slave interface
- For plants with high processing performance and response time requirements
- With technological functions
- For tasks with special functions
- For connecting distributed I/Os

SIMATIC Micro Memory Card required for operation of the CPU.

SIMATIC S7-300

Central processing units

Compact CPUs

Overview CPU 314C-2 PtP



- The compact CPU with integrated digital and analog inputs/outputs as well as second serial interface
- For plants with high processing performance and response time requirements
- With technological functions

SIMATIC Micro Memory Card required for operation of the CPU.

Overview CPU 314C-2 DP



- The compact CPU with integral digital and analog inputs/outputs and PROFIBUS DP master/slave interface
- With technological functions
- For plants with high processing performance and response time requirements
- For connecting distributed I/Os

SIMATIC Micro Memory Card required for operation of the CPU.

Overview CPU 314C-2 PN/DP



- The compact CPU with integral digital and analog inputs/outputs and technological functions
- High processing performance in binary and floating-point arithmetic
- For connecting distributed I/O via PROFIBUS and PROFINET
- Combined MPI/PROFIBUS DP master/slave interface
- PROFINET interface with 2-port switch
- PROFINET IO Controller for operating distributed I/O on PROFINET
- PROFINET I-Device for connecting the CPU as intelligent PROFINET device under a SIMATIC or third-party PROFINET I/O controller
- Component based Automation (CBA) on PROFINET
- PROFINET proxy for intelligent devices on PROFIBUS DP in Component based Automation (CBA)
- Integrated Web server with the option of creating user-defined web pages
- Isochronous mode on PROFINET

SIMATIC Micro Memory Card required for operation of CPU.

SIMATIC S7-300

Central processing units

Compact CPUs

Technical specifications

	6ES7 312-5BF04-0AB0	6ES7 313-5BG04-0AB0	6ES7 313-6BG04-0AB0	6ES7 313-6CG04-0AB0
General information				
Engineering with				
• Programming package	STEP 7 V5.5 + SP1 or higher or STEP 7 V5.3 + SP2 or higher with HSP 203	STEP 7 V5.5 + SP1 or higher or STEP 7 V5.3 + SP2 or higher with HSP 203	STEP7 as of V5.5 + SP1 or STEP 7 V5.3 + SP2 or higher with HSP 204	STEP 7 V5.5 + SP1 or higher or STEP 7 V5.3 + SP2 or higher with HSP 203
Supply voltage				
24 V DC	Yes	Yes	Yes	Yes
Power losses				
Power loss, typ.	8 W	12 W	9 W	9 W
Memory				
Work memory				
• integrated	64 kbyte	128 kbyte	128 kbyte	128 kbyte
• Size of retentive memory for retentive data blocks	64 kbyte	64 kbyte	64 kbyte	64 kbyte
Load memory				
• pluggable (MMC), max.	8 Mbyte	8 Mbyte	8 Mbyte	8 Mbyte
CPU processing times				
for bit operations, typ.	0.1 µs	0.07 µs	0.07 µs	0.07 µs
for word operations, typ.	0.24 µs	0.15 µs	0.15 µs	0.15 µs
for fixed point arithmetic, typ.	0.32 µs	0.2 µs	0.2 µs	0.2 µs
for floating point arithmetic, typ.	1.1 µs	0.72 µs	0.72 µs	0.72 µs
Counters, timers and their retentivity				
S7 counter				
• Number	256	256	256	256
IEC counter				
• present	Yes	Yes	Yes	Yes
S7 times				
• Number	256	256	256	256
IEC timer				
• present	Yes	Yes	Yes	Yes
Data areas and their retentivity				
Flag				
• Number, max.	256 byte	256 byte	256 byte	256 byte
Address area				
I/O address area				
• Inputs	1 024 byte	1 024 byte	1 024 byte	2 048 byte
• Outputs	1 024 byte	1 024 byte	1 024 byte	2 048 byte
Process image				
• Inputs, adjustable	1 024 byte	1 024 byte	1 024 byte	2 048 byte
• Outputs, adjustable	1 024 byte	1 024 byte	1 024 byte	2 048 byte
Time of day				
Clock				
• Hardware clock (real-time clock)		Yes	Yes	Yes
Operating hours counter				
• Number	1	1	1	1
Digital inputs				
integrated channels (DI)	10	24	16	16
Digital outputs				
integrated channels (DO)	6	16	16	16
Analog inputs				
Integrated channels (AI)	0	5; 4 x current/voltage, 1 x resistance	0	0
Input ranges				
• Voltage		Yes; ±10 V / 100 kΩ; 0 V to 10 V / 100 kΩ		
• Current		Yes; ±20 mA / 100 Ω; 0 mA to 20 mA / 100 Ω; 4 mA to 20 mA / 100 Ω		
• Resistance thermometer		Yes; Pt 100 / 10 MΩ		
• Resistance		Yes; 0 Ω to 600 Ω / 10 MΩ		

Technical specifications (continued)

	6ES7 312-5BF04-0AB0	6ES7 313-5BG04-0AB0	6ES7 313-6BG04-0AB0	6ES7 313-6CG04-0AB0
Analog outputs				
Integrated channels (AO)	0	2	0	0
Output ranges, voltage				
• 0 to 10 V		Yes		
• -10 to +10 V		Yes		
Output ranges, current				
• 0 to 20 mA		Yes		
• -20 to +20 mA		Yes		
• 4 to 20 mA		Yes		
1st interface				
Type of interface	Integrated RS 485 interface	Integrated RS 485 interface	Integrated RS 485 interface	Integrated RS 485 interface
Physics	RS 485	RS 485	RS 485	RS 485
Functionality				
• MPI	Yes	Yes	Yes	Yes
• DP master	No	No	No	No
• DP slave	No	No	No	No
• Point-to-point connection	No	No	No	No
2nd interface				
Type of interface			Integrated RS 422/485 interface	Integrated RS 485 interface
Physics			RS 422/RS 485 (X.27)	RS 485
Functionality				
• MPI			No	No
• DP master			No	Yes
• DP slave			No	Yes
• PROFINET IO Controller			No	No
• PROFINET IO Device			No	No
• PROFINET CBA			No	No
DP master				
• Number of DP slaves, max.				124
Communication functions				
PG/OP communication	Yes	Yes	Yes	Yes
Data record routing	No	No	No	Yes
Global data communication				
• supported	Yes	Yes	Yes	Yes
S7 basic communication				
• supported	Yes	Yes	Yes; Server	Yes
S7 communication				
• supported	Yes	Yes	Yes	Yes
S5-compatible communication				
• supported	Yes; via CP and loadable FC	Yes; via CP and loadable FC	Yes; via CP and loadable FC	Yes; via CP and loadable FC
Number of connections				
• overall	6	8	8	8

SIMATIC S7-300

Central processing units

Compact CPUs

Technical specifications (continued)

	6ES7 312-5BF04-0AB0	6ES7 313-5BG04-0AB0	6ES7 313-6BG04-0AB0	6ES7 313-6CG04-0AB0
Integrated Functions				
Number of counters	2; See "Technological Functions" manual	3; See "Technological Functions" manual	3; See "Technological Functions" manual	3; See "Technological Functions" manual
Counter frequency (counter) max.	10 kHz	30 kHz	30 kHz	30 kHz
Frequency measurement	Yes	Yes	Yes	Yes
Number of frequency meters	2; up to 10 kHz (see "Technological Functions" manual)	3; up to 30 kHz (see "Technological Functions" manual)	3; up to 30 kHz (see "Technological Functions" manual)	3; up to 30 kHz (see "Technological Functions" manual)
controlled positioning	No	No	No	No
Integrated function blocks (closed-loop control)	No	Yes; PID controller (see "Technological Functions" manual)	Yes; PID controller (see "Technological Functions" manual)	Yes; PID controller (see "Technological Functions" manual)
PID controller	No	Yes	Yes	Yes
Number of pulse outputs	2; Pulse width modulation up to 2.5 kHz (see "Technological Functions" Manual)	3; Pulse width modulation up to 2.5 kHz (see "Technological Functions" Manual)	3; Pulse width modulation up to 2.5 kHz (see "Technological Functions" Manual)	3; Pulse width modulation up to 2.5 kHz (see "Technological Functions" Manual)
Limit frequency (pulse)	2.5 kHz	2.5 kHz	2.5 kHz	2.5 kHz
Ambient conditions				
Operating temperature				
• Min.	0 °C	0 °C	0 °C	0 °C
• max.	60 °C	60 °C	60 °C	60 °C
Configuration				
programming				
• Programming language				
- LAD	Yes	Yes	Yes	Yes
- FBD	Yes	Yes	Yes	Yes
- STL	Yes	Yes	Yes	Yes
- SCL	Yes	Yes	Yes	Yes
- CFC	Yes	Yes	Yes	Yes
- GRAPH	Yes	Yes	Yes	Yes
- HiGraph®	Yes	Yes	Yes	Yes
Know-how protection				
• User program protection/ password protection	Yes	Yes	Yes	Yes
• Block encryption	Yes; With S7 block Privacy	Yes; With S7 block Privacy	Yes; With S7 block Privacy	Yes; With S7 block Privacy
Dimensions				
Width	80 mm	120 mm	80 mm	80 mm
Height	125 mm	125 mm	125 mm	125 mm
Depth	130 mm	130 mm	130 mm	130 mm
Weight				
Weight, approx.	410 g	660 g	500 g	500 g

Technical specifications (continued)

	6ES7 314-6BH04-0AB0	6ES7 314-6CH04-0AB0	6ES7 314-6EH04-0AB0
General information			
Engineering with • Programming package	STEP7 as of V5.5 + SP1 or STEP 7 V5.3 + SP2 or higher with HSP 204	STEP 7 V5.5 + SP1 or higher or STEP 7 V5.3 + SP2 or higher with HSP 203	STEP7 V5.5 or higher with HSP191
Supply voltage			
24 V DC	Yes	Yes	Yes
Power losses			
Power loss, typ.	13 W	13 W	14 W
Memory			
Work memory • integrated • Size of retentive memory for retentive data blocks	192 kbyte 64 kbyte	192 kbyte 64 kbyte	192 kbyte 64 kbyte
Load memory • pluggable (MMC), max.	8 Mbyte	8 Mbyte	8 Mbyte
CPU processing times			
for bit operations, typ.	0.06 µs	0.06 µs	0.06 µs
for word operations, typ.	0.12 µs	0.12 µs	0.12 µs
for fixed point arithmetic, typ.	0.16 µs	0.16 µs	0.16 µs
for floating point arithmetic, typ.	0.59 µs	0.59 µs	0.59 µs
Counters, timers and their retentivity			
S7 counter • Number	256	256	256
IEC counter • present	Yes	Yes	Yes
S7 times • Number	256	256	256
IEC timer • present	Yes	Yes	Yes
Data areas and their retentivity			
Flag • Number, max.	256 byte	256 byte	256 byte
Address area			
I/O address area • Inputs • Outputs	1 024 byte 1 024 byte	2 048 byte 2 048 byte	2 048 byte 2 048 byte
Process image • Inputs, adjustable • Outputs, adjustable	1 024 byte 1 024 byte	2 048 byte 2 048 byte	2 048 byte 2 048 byte
Time of day			
Clock • Hardware clock (real-time clock)	Yes	Yes	Yes
Operating hours counter • Number	1	1	1
Digital inputs			
integrated channels (DI)	24	24	24
Digital outputs			
integrated channels (DO)	16	16	16
Analog inputs			
Integrated channels (AI)	5; 4 x current/voltage, 1 x resistance	5; 4 x current/voltage, 1 x resistance	5; 4 x current/voltage, 1 x resistance
Input ranges • Voltage • Current • Resistance thermometer • Resistance	Yes; ±10 V / 100 kΩ; 0 V to 10 V / 100 kΩ Yes; ±20 mA / 100 Ω; 0 mA to 20 mA / 100 Ω; 4 mA to 20 mA / 100 Ω Yes; Pt 100 / 10 MΩ Yes; 0 Ω to 600 Ω / 10 MΩ	Yes; ±10 V / 100 kΩ; 0 V to 10 V / 100 kΩ Yes; ±20 mA / 100 Ω; 0 mA to 20 mA / 100 Ω; 4 mA to 20 mA / 100 Ω Yes; Pt 100 / 10 MΩ Yes; 0 Ω to 600 Ω / 10 MΩ	Yes; ±10 V / 100 kΩ; 0 V to 10 V / 100 kΩ Yes; ±20 mA / 100 Ω; 0 mA to 20 mA / 100 Ω; 4 mA to 20 mA / 100 Ω Yes; Pt 100 / 10 MΩ Yes; 0 Ω to 600 Ω / 10 MΩ

SIMATIC S7-300

Central processing units

Compact CPUs

Technical specifications (continued)

	6ES7 314-6BH04-0AB0	6ES7 314-6CH04-0AB0	6ES7 314-6EH04-0AB0
Analog outputs			
Integrated channels (AO)	2	2	2
Output ranges, voltage			
• 0 to 10 V	Yes	Yes	Yes
• -10 to +10 V	Yes	Yes	Yes
Output ranges, current			
• 0 to 20 mA	Yes	Yes	Yes
• -20 to +20 mA	Yes	Yes	Yes
• 4 to 20 mA	Yes	Yes	Yes
1st interface			
Type of interface	Integrated RS 485 interface	Integrated RS 485 interface	Integrated RS 485 interface
Physics	RS 485	RS 485	RS 485
Functionality			
• MPI	Yes	Yes	Yes
• DP master	No	No	Yes
• DP slave	No	No	Yes
• Point-to-point connection	No	No	No
DP master			
• Number of DP slaves, max.			124
2nd interface			
Type of interface	Integrated RS 422/ 485 interface	Integrated RS 485 interface	PROFINET
Physics	RS 422/RS 485 (X.27)	RS 485	Ethernet RJ45
Number of ports			2
Functionality			
• MPI	No	No	No
• DP master	No	Yes	No
• DP slave	No	Yes	No
• PROFINET IO Controller	No	No	Yes; Also simultaneously with IO-Device functionality
• PROFINET IO Device	No	No	Yes; Also simultaneously with IO Controller functionality
• PROFINET CBA	No	No	Yes
DP master			
• Number of DP slaves, max.		124	
PROFINET IO Controller			
• Max. number of connectable IO devices for RT			128
• Number of IO devices with IRT and the option "high flexibility"			128
• Number of IO Devices with IRT and the option "high performance", max.			64
Isochronous mode			
Isochronous operation (application synchronized up to terminal)			Yes; For PROFINET only
Communication functions			
PG/OP communication	Yes	Yes	Yes
Data record routing	No	Yes	Yes
Global data communication			
• supported	Yes	Yes	Yes
S7 basic communication			
• supported	Yes	Yes	Yes
S7 communication			
• supported	Yes	Yes	Yes
S5-compatible communication			
• supported	Yes; via CP and loadable FC	Yes; via CP and loadable FC	Yes; via CP and loadable FC

Technical specifications (continued)

	6ES7 314-6BH04-0AB0	6ES7 314-6CH04-0AB0	6ES7 314-6EH04-0AB0
Open IE communication			
• TCP/IP			Yes; via integrated PROFINET interface and loadable FBs 8
- Number of connections, max.			Yes; via integrated PROFINET interface and loadable FBs 8
• ISO-on-TCP (RFC1006)			Yes; via integrated PROFINET interface and loadable FBs 8
- Number of connections, max.			Yes; via integrated PROFINET interface and loadable FBs 8
• UDP			Yes; via integrated PROFINET interface and loadable FBs 8
- Number of connections, max.			
Web server			
• supported			Yes
Number of connections			
• overall	12	12	12
Integrated Functions			
Number of counters	4; See "Technological Functions" manual	4; See "Technological Functions" manual	4; See "Technological Functions" manual
Counter frequency (counter) max.	60 kHz	60 kHz	60 kHz
Frequency measurement	Yes	Yes	Yes
Number of frequency meters	4; up to 60 kHz (see "Technological Functions" manual)	4; up to 60 kHz (see "Technological Functions" manual)	4; up to 60 kHz (see "Technological Functions" manual)
controlled positioning	Yes	Yes	Yes
Integrated function blocks (closed-loop control)	Yes; PID controller (see "Technological Functions" manual)	Yes; PID controller (see "Technological Functions" manual)	Yes; PID controller (see "Technological Functions" manual)
PID controller	Yes	Yes	Yes
Number of pulse outputs	4; Pulse width modulation up to 2.5 kHz (see "Technological Functions" Manual)	4; Pulse width modulation up to 2.5 kHz (see "Technological Functions" Manual)	4; Pulse width modulation up to 2.5 kHz (see "Technological Functions" Manual)
Limit frequency (pulse)	2.5 kHz	2.5 kHz	2.5 kHz
Ambient conditions			
Operating temperature			
• Min.	0 °C	0 °C	0 °C
• max.	60 °C	60 °C	60 °C
Configuration			
programming			
• Programming language			
- LAD	Yes	Yes	Yes
- FBD	Yes	Yes	Yes
- STL	Yes	Yes	Yes
- SCL	Yes	Yes	Yes
- CFC	Yes	Yes	Yes
- GRAPH	Yes	Yes	Yes
- HiGraph®	Yes	Yes	Yes
Know-how protection			
• User program protection/password protection	Yes	Yes	Yes
• Block encryption	Yes; With S7 block Privacy	Yes; With S7 block Privacy	Yes; With S7 block Privacy
Dimensions			
Width	120 mm	120 mm	120 mm
Height	125 mm	125 mm	125 mm
Depth	130 mm	130 mm	130 mm
Weight			
Weight, approx.	680 g	680 g	730 g

SIMATIC S7-300

Central processing units

Compact CPUs

Ordering data	Order No.	Order No.
CPU 312C Compact CPU, 64 KB main memory, 24 V DC power supply, 10 DI/6 DO integrated, integrated functions, MPI; including slot number labels; MMC required	6ES7 312-5BF04-0AB0	6ES7 901-0BF00-0AA0
CPU 313C Compact CPU, 128 KB main memory, 24 V DC power supply, 24 DI/16 DO, 4 AI/2 AO integrated, integrated functions, MPI; MMC required	6ES7 313-5BG04-0AB0	6ES7 902-3AB00-0AA0 6ES7 902-3AC00-0AA0 6ES7 902-3AG00-0AA0
CPU 313C-2 PtP Compact CPU, 128 KB, 24 V DC power supply, 16 DI/16 DO integrated, integrated functions, MPI, RS 422/485 interface; MMC required	6ES7 313-6BG04-0AB0	6ES7 392-1AM00-0AA0 6ES7 392-1AM00-1AB0
CPU 313C-2 DP Compact CPU, 128 KB main memory, 24 V DC power supply, 16 DI/16 DO integrated, integrated functions, MPI, PROFIBUS DP master/slave interface; MMC required	6ES7 313-6CG04-0AB0	6ES7 392-1BM01-0AA0 6ES7 392-1BM01-1AB0
CPU 314C-2 PtP Compact CPU, 192 KB main memory, 24 V DC power supply, 24DI/16DO/4AI/2AO integrated, integrated functions, MPI, RS 422/485 interface; MMC required	6ES7 314-6BH04-0AB0	6ES7 912-0AA00-0AA0
CPU 314C-2 DP Compact CPU, 192 KB main memory, 24 V DC power supply, 24DI/16DO/4AI/2AO integrated, integrated functions, MPI, PROFIBUS DP master/slave interface; MMC required	6ES7 314-6CH04-0AB0	6ES7 398-8FA10-8AA0 6ES7 398-8FA10-8BA0
CPU 314C-2 PN/DP Compact CPU, 192 KB main memory, 24 V DC power supply, 24 DI/16 DO/4 AI/2 AO integrated, integrated functions, MPI; PROFIBUS DP master/slave interface; PROFINET IO Controller/I-Device interface, MMC is required	6ES7 314-6EH04-0AB0	6ES7 998-8XC01-8YE0
SIMATIC Micro Memory Card 64 KB 128 KB 512 KB 2 MB 4 MB 8 MB	6ES7 953-8LF20-0AA0 6ES7 953-8LG20-0AA0 6ES7 953-8LJ30-0AA0 6ES7 953-8LL31-0AA0 6ES7 953-8LM20-0AA0 6ES7 953-8LP20-0AA0	S7-300 manual Design, CPU data, module data, instruction list German 6ES7 398-8FA10-8AA0 English 6ES7 398-8FA10-8BA0 SIMATIC Manual Collection Electronic manuals on DVD, multilingual: LOGO!, SIMADYN, SIMATIC bus components, SIMATIC C7, SIMATIC distributed I/O, SIMATIC HMI, SIMATIC Sensors, SIMATIC NET, SIMATIC PC Based Automation, SIMATIC PCS 7, SIMATIC PG/PC, SIMATIC S7, SIMATIC Software, SIMATIC TDC SIMATIC Manual Collection update service for 1 year Current "Manual Collection" DVD and the three subsequent updates Power supply connector 10 units, spare part Labeling strips 10 units, spare part Label cover 10 units, spare part

Ordering data	Order No.	Order No.	
Labeling sheets for machine inscription For 32-channel signal modules, DIN A4, for printing with laser printer; 10 units petrol light-beige yellow red	6ES7 392-2AX10-0AA0 6ES7 392-2BX10-0AA0 6ES7 392-2CX10-0AA0 6ES7 392-2DX10-0AA0	PROFINET bus components IE FC TP Standard Cable GP 2x2 4-core, shielded TP installation cable for connection to IE FC Outlet RJ45/ IE FC RJ45 Plug; PROFINET-compatible; with UL approval; sold by the meter FO Standard Cable GP (50/125) Standard cable, splittable, UL approval, sold by the meter SCALANCE X204-2 Industrial Ethernet Switch Industrial Ethernet Switches with integral SNMP access, web diagnostics, copper cable diagnostics and PROFINET diagnostics for configuring line, star and ring topologies; four 10/100 Mbit/s RJ45 ports and two FO ports CSM 377 Compact Switch Module Unmanaged switch for connecting a SIMATIC S7-300, ET200 M and up to three other stations to Industrial Ethernet with 10/100 Mbit/s; 4 x RJ45 ports; external 24 V DC power supply, LED diagnostics, S7-300 module incl. electronic manual on CD-ROM IE FC RJ45 plugs RJ45 plug connector for Industrial Ethernet with a rugged metal enclosure and integrated insulation displacement contacts for connecting Industrial Ethernet FC installation cables IE FC RJ45 plug 180 180° cable outlet 1 unit 10 units 50 units PROFIBUS/PROFINET bus components For establishing MPI/PROFIBUS/PROFINET communication	6XV1 840-2AH10 6XV1 873-2A 6GK5 204-2BB10-2AA3 6GK7 377-1AA00-0AA0 6GK1 901-1BB10-2AA0 6GK1 901-1BB10-2AB0 6GK1 901-1BB10-2AE0 See catalogs IK PI, CA 01
PC adapter USB A2 For connecting a PG/PC or notebook to PROFIBUS or MPI, USB cable included in scope of supply	6GK1 571-0BA00-0AA0		
PROFIBUS DP bus connector RS 485 <ul style="list-style-type: none"> With 90° cable outlet, max. transfer rate 12 Mbit/s <ul style="list-style-type: none"> without PG interface with PG interface With 90° cable outlet for FastConnect connection system, max. transfer rate 12 Mbit/s <ul style="list-style-type: none"> without PG interface, 1 unit without PG interface, 100 units with PG interface, 1 unit with PG interface, 100 units With axial cable outlet for SIMATIC OP, for connecting to PPI, MPI, PROFIBUS 	6ES7 972-0BA12-0XA0 6ES7 972-0BB12-0XA0 6ES7 972-0BA52-0XA0 6ES7 972-0BA52-0XB0 6ES7 972-0BB52-0XA0 6ES7 972-0BB52-0XB0 6GK1 500-0EA02		
PROFIBUS Fast Connect bus cable Standard type with special design for quick mounting, 2-core, shielded, sold by the meter, max. delivery unit 1000 m, minimum ordering quantity 20 m	6XV1 830-0EH10		
RS 485 repeater for PROFIBUS Transmission rate up to 12 Mbit/s; 24 V DC; IP20 enclosure	6ES7 972-0AA02-0XA0		

SIMATIC S7-300

Central processing units

SIPLUS compact CPUs

Overview SIPLUS CPU 312C



- The compact CPU with integral digital inputs/outputs
- For small applications with increased processing performance requirements
- With technological functions

Micro Memory Card required for operation of CPU.

Note:

SIPLUS extreme products are based on Siemens Industry standard products. The contents listed here were taken from the respective standard products. SIPLUS extreme-specific information was added.

5

SIPLUS CPU 312C	6AG1 312-5BF04-7AB0	6AG1 312-5BF04-2AY0
Order No.	6AG1 312-5BF04-7AB0	6AG1 312-5BF04-2AY0
Order No. based on	6ES7 312-5BF04-0AB0	6ES7 312-5BF04-0AB0
Ambient temperature range	-25 ... +70 °C	-25 ... +60 °C
Conformal coating	Coating of the printed circuit boards and the electronic components	
Technical data	The technical data of the standard product applies except for the ambient conditions	
Conforms with standard for electronic equipment used on rolling stock (EN 50155, temperature T1, category 1).	No	Yes
Ambient conditions		
Relative humidity	100%, condensation/frost permissible. No commissioning if condensation present.	
Biologically active substances, compliance with EN 60721-3-3	Class 3B2 mold and fungal spores (excluding fauna). The supplied plug covers must remain in place over the unused interfaces during operation!	
Chemically active substances, compliance with EN 60721-3-3	Class 3C4 incl. salt spray in accordance with EN 60068-2-52 (degree of severity 3). The supplied plug covers must remain in place over the unused interfaces during operation!	
Mechanically active substances, compliance with EN 60721-3-3	Class 3S4 incl. sand, dust. The supplied plug covers must remain in place over the unused interfaces during operation!	
Air pressure (depending on the highest positive temperature range specified)	1080 ... 795 hPa (-1000 ... +2000 m) see ambient temperature range 795 ... 658 hPa (+2 000 ... +3 500 m) derating 10 K 658 ... 540 hPa (+3500 ... +5000 m) derating 20 K	

Technical documentation on SIPLUS can be found here:
www.siemens.com/siplus-extreme

Ordering data	Order No.
SIPLUS CPU 312C (extended temperature range and medial exposure) Compact CPU, 64 KB main memory, 24 V DC power supply, 10 DI/6 DO integrated, integrated functions, MPI; including slot number labels; MMC required Additional conformance with EN 50155	6AG1 312-5BF04-7AB0 6AG1 312-5BF04-2AY0
Accessories	See SIMATIC CPU 312C, page 5/26

Overview SIPLUS CPU 313C



- The compact CPU with integral digital and analog inputs/ outputs
- For plants with high processing performance and response time requirements
- With technological functions

Micro Memory Card required to operate the CPU.

Note:

SIPLUS extreme products are based on Siemens Industry standard products. The contents listed here were taken from the respective standard products. SIPLUS extreme-specific information was added.

Technical specifications

The technical data correspond to those of the based-on modules apart from the values listed in the table.

SIPLUS CPU 313C		
Order No.	6AG1 313-5BG04-2AY0	6AG1 313-5BG04-7AB0
Order No. based on	6ES7 313-5BG04-0AB0	6ES7 313-5BG04-0AB0
Ambient conditions		
Operating temperature		
• Min.	-25 °C; = Tmin	-25 °C; = Tmin
• max.	60 °C; = Tmax; the rated temperature range of -25 ... +55 °C (T1) applies for the use on railway vehicles according to EN50155	70 °C; = Tmax
Extended ambient conditions		
• Relative to ambient temperature-atmospheric pressure-installation altitude	Tmin ... Tmax at 1080 hPa ... 795 hPa (-1000 m ... +2000 m) // Tmin ... (Tmax - 10K) at 795 hPa ... 658 hPa (+2000 m ... +3500 m) // Tmin ... (Tmax - 20K) at 658 hPa ... 540 hPa (+3500 m ... +5000 m)	
• Relative humidity	100 %; RH incl. condensation/frost (no commissioning under condensation conditions)	
- With condensation/maximum/ tested in accordance with IEC 60068-2-38		
• Resistance	Yes; Class 3B2 mold, fungus and dry rot spores (with the exception of fauna). The supplied connector covers must remain on the unused interfaces during operation!	
- to biologically active substances	Yes; Class 3C4 (RH < 75%) incl. salt spray according to EN 60068-2-52 (degree of severity 3). The supplied connector covers must remain on the unused interfaces during operation!	
- to chemically active substances	Yes; Class 3S4 incl. sand, dust. The supplied connector covers must remain on the unused interfaces during operation!	
- to mechanically active substances		

Ordering data

Ordering data	Order No.
SIPLUS CPU 313C	
(extended temperature range and medial exposure)	
Compact CPU, 128 KB main memory, 24 V DC power supply, 24 DI/16 DO, 4 AI/2 AO integrated, integrated functions, MPI; MMC required	6AG1 313-5BG04-7AB0
Additional conformance with EN 50155	6AG1 313-5BG04-2AY0
Accessories	See SIMATIC CPU 313C, page 5/26

SIMATIC S7-300

Central processing units

SIPLUS compact CPUs

Overview SIPLUS CPU 313C-2DP



- The compact CPU with integral digital inputs/outputs and PROFIBUS DP master/slave interface
- With technological functions
- For tasks with special functions
- For connecting distributed I/O

Micro Memory Card required for operation of CPU.

Note:

SIPLUS extreme products are based on Siemens Industry standard products. The contents listed here were taken from the respective standard products. SIPLUS extreme-specific information was added.

SIPLUS CPU 313C-2 DP

Order No.	6AG1 313-6CG04-7AB0	6AG1 313-6CG04-2AY0
Order No. based on	6ES7 313-6CG04-0AB0	6ES7 313-6CG04-0AB0
Ambient temperature range	-25 ... +70 °C	-25 ... +60 °C
Conformal coating	Coating of the printed circuit boards and the electronic components	
Technical data	The technical data of the standard product applies, except for the ambient conditions	
Compliant with the standards for electronic equipment used on rolling stock (EN 50155, temperature T1, category 1).	No	Yes

Ambient conditions

Relative humidity	100%, condensation/frost permissible. No commissioning if condensation present.
Biologically active substances, compliance with EN 60721-3-3	Class 3B2 mold and fungal spores (excluding fauna). The supplied plug covers must remain in place over the unused interfaces during operation!
Chemically active substances, compliance with EN 60721-3-3	Class 3C4 incl. salt spray in accordance with EN 60068-2-52 (degree of severity 3). The supplied plug covers must remain in place over the unused interfaces during operation!
Mechanically active substances, compliance with EN 60721-3-3	Class 3S4 incl. sand, dust. The supplied plug covers must remain in place over the unused interfaces during operation!
Air pressure (depending on the highest positive temperature range specified)	1 080 ... 795 hPa (-1 000 ... +2 000 m) see ambient temperature range 795 ... 658 hPa (+2 000 ... +3 500 m) derating 10 K 658 ... 540 hPa (+3 500 ... +5 000 m) derating 20 K

Technical documentation on SIPLUS can be found here:
www.siemens.com/siplus-extreme

Ordering data

SIPLUS CPU 313C-2 DP

(extended temperature range and medial exposure)

Compact CPU, 128 KB work memory, power supply 24 V DC, 16 DI/16 DO integrated, integrated functions, MPI, PROFIBUS DP master/slave interface; MMC required

Additional conformance with EN 50155

Accessories

Order No.

6AG1 313-6CG04-7AB0

6AG1 313-6CG04-2AY0

See SIMATIC CPU 313C-2 DP, page 5/26

SIMATIC S7-300

Central processing units

SIPLUS compact CPUs

Overview SIPLUS CPU 314C-2 PtP



- The compact CPU with integrated digital and analog inputs/outputs as well as second serial interface
- For plants with high processing performance and response time requirements
- With technological functions

SIMATIC Micro Memory Card required for operation of CPU.

Note:

SIPLUS extreme products are based on Siemens Industry standard products. The contents listed here were taken from the respective standard products. SIPLUS extreme-specific information was added.

SIPLUS CPU 314C-2 PtP

Order No.	6AG1 314-6BH04-7AB0
Order No. based on	6ES7 314-6BH04-0AB0
Ambient temperature range	-25 ... +70 °C
Conformal coating	Coating of the printed circuit boards and the electronic components
Technical data	The technical data of the standard product applies except for the ambient conditions

Ambient conditions

Relative humidity	100%, condensation/frost permissible. No commissioning if condensation present.
Biologically active substances, compliance with EN 60721-3-3	Class 3B2 mold and fungal spores (excluding fauna). The supplied plug covers must remain in place over the unused interfaces during operation!
Chemically active substances, compliance with EN 60721-3-3	Class 3C4 incl. salt spray in accordance with EN 60068-2-52 (degree of severity 3). The supplied plug covers must remain in place over the unused interfaces during operation!
Mechanically active substances, compliance with EN 60721-3-3	Class 3S4 incl. sand, dust. The supplied plug covers must remain in place over the unused interfaces during operation!
Air pressure (depending on the highest positive temperature range specified)	1080 ... 795 hPa (-1000 ... +2000 m) see ambient temperature range 795 ... 658 hPa (+2000 ... +3500 m) derating 10 K 658 ... 540 hPa (+3500 ... +5000 m) derating 20 K

Technical documentation on SIPLUS can be found here:
www.siemens.com/siplus-extreme

Ordering data

Order No.

SIPLUS CPU 314C-2 PtP

(extended temperature range and medial exposure)

Compact CPU, 192 KB main memory, 24 V DC power supply, 24DI/16DO/4AI/2AO integrated, integrated functions, MPI, RS 422/485 interface; MMC required

6AG1 314-6BH04-7AB0

Accessories

See SIMATIC CPU 314C-2 PtP, page 5/26

SIMATIC S7-300

Central processing units

SIPLUS compact CPUs

Overview SIPLUS CPU 314C-2 DP



- The compact CPU with integral digital and analog inputs/ outputs and PROFIBUS DP master/slave interface
- With technological functions
- For tasks with special functions
- For connecting distributed I/O

Micro Memory Card required for operation of CPU.

Note:

SIPLUS extreme products are based on Siemens Industry standard products. The contents listed here were taken from the respective standard products. SIPLUS extreme-specific information was added.

SIPLUS CPU 314C-2 DP

Order No.	6AG1 314-6CH04-7AB0	6AG1 314-6CH04-2AY0
Order No. based on	6ES7 314-6CH04-0AB0	6ES7 314-6CH04-0AB0
Ambient temperature range	-25 ... +70 °C	-25 ... +60 °C
Conformal coating	Coating of the printed circuit boards and the electronic components	
Technical data	The technical data of the standard product applies except for the ambient conditions	
Conforms with standard for electronic equipment used on rolling stock (EN 50155).	No	Yes

Ambient conditions

Relative humidity	100%, condensation/frost permissible. No commissioning if condensation present.	
Biologically active substances, compliance with EN 60721-3-3	Class 3B2 mold and fungal spores (excluding fauna). The supplied plug covers must remain in place over the unused interfaces during operation!	
Chemically active substances, compliance with EN 60721-3-3	Class 3C4 incl. salt spray in accordance with EN 60068-2-52 (degree of severity 3). The supplied plug covers must remain in place over the unused interfaces during operation!	
Mechanically active substances, compliance with EN 60721-3-3	Class 3S4 incl. sand, dust. The supplied plug covers must remain in place over the unused interfaces during operation!	
Air pressure (depending on the highest positive temperature range specified)	1 080 ... 795 hPa (-1 000 ... +2 000 m) see ambient temperature range 795 ... 658 hPa (+2 000 ... +3 500 m) derating 10 K 658 ... 540 hPa (+3 500 ... +5 000 m) derating 20 K	

Technical documentation on SIPLUS can be found here:

www.siemens.com/siplus-extreme

Ordering data

SIPLUS CPU 314C-2 DP

(extended temperature range and medial exposure)

Compact CPU, 192 KB main memory, 24 V DC power supply, 24DI/16DO/4AI/2AO integrated, integrated functions, MPI, PROFIBUS DP master/slave interface; MMC required

Additional conformance with EN 50155

Accessories

Order No.

6AG1 314-6CH04-7AB0

6AG1 314-6CH04-2AY0

See SIMATIC CPU 314C-2 DP, page 5/26

SIMATIC S7-300

Central processing units

Fail-safe CPUs

Overview CPU 315F-2 DP



- Based on the SIMATIC CPU 315-2 DP
- For setting up a fail-safe automation system in plants with increased safety requirements
- Complies with safety requirements up to SIL 3 according to IEC 61508 and up to Cat. 4 according to EN 954-1
- Distributed fail-safe I/O modules can be connected through the integral PROFIBUS DP interface (PROFIsafe)
- Fail-safe I/O modules of the ET 200M range can also be centrally connected
- Central and distributed use of standard modules for non safety-oriented applications

SIMATIC Micro Memory Card required for operation of CPU.

- Fail-safe I/O modules in distributed stations can be connected through the integrated PROFINET interface (PROFIsafe) and/or through the integrated PROFIBUS DP interface (PROFIsafe);
- Fail-safe I/O modules of the ET 200M range can also be centrally connected
- Central and distributed use of standard modules for non safety-relevant applications
- Component Based Automation (CBA) on PROFINET
- PROFINET IO Controller for operating distributed I/O on PROFINET
- PROFINET interface with 2-port switch
- PROFINET proxy for intelligent devices on PROFIBUS DP in Component Based Automation (CBA)

SIMATIC Micro Memory Card required for operation of CPU.

Overview CPU 317F-2 DP



- The fail-safe CPU with a large program memory and quantity framework for demanding applications
- For constructing a fail-safe automation system for plants with increased safety requirements
- Satisfies safety requirements up to SIL 3 acc. to IEC 61508 and up to Cat. 4 acc. to EN 954-1
- Fail-safe I/O modules can be connected in a distributed configuration to both integral PROFIBUS DP interfaces (PROFIsafe)
- Fail-safe I/O modules of the ET 200M range can also be centrally connected
- Central and distributed use of standard modules for non safety-relevant applications

SIMATIC Micro Memory Card required for operation of CPU.

Overview CPU 315F-2 PN/DP



- Based on CPU 315-2 PN/DP
- The CPU with medium-sized program memory and quantity structures for setting up a fail-safe automation system in plants with increased safety requirements
- Complies with safety requirements up to SIL 3 according to IEC 61508, PL e according to ISO 13849, and up to Cat. 4 according to EN 954-1

SIMATIC S7-300

Central processing units

Fail-safe CPUs

Overview CPU 317F-2 PN/DP



- Based on CPU 317-2 PN/DP
- The fail-safe CPU with a large program memory and quantity framework for demanding applications; for setting up a fail-safe automation system in plants with increased safety requirements.
- Complies with safety requirements up to SIL 3 according to IEC 61508, PL e according to ISO 13849-1, and up to Cat. 4 according to EN 954-1
- Fail-safe I/O modules in distributed stations can be connected through the integrated PROFINET interface (PROFIsafe) and/or through the integrated PROFIBUS DP interface (PROFIsafe)
- Fail-safe I/O modules of the ET 200M range can also be centrally connected
- Central and distributed use of standard modules for non safety-relevant applications
- Component Based Automation (CBA) on PROFINET
- PROFINET IO Controller for operating distributed I/O on PROFINET
- PROFINET interface with 2-port switch
- PROFINET proxy for intelligent devices on PROFIBUS DP in Component Based Automation (CBA)

SIMATIC Micro Memory Card required for operation of CPU.

Overview CPU 319F-3 PN/DP



- The fail-safe CPU with high-performance command processing, large program memory and large quantity structure for demanding applications
- For constructing a fail-safe automation system for plants with increased safety requirements
- Complies with safety requirements up to SIL 3 according to IEC 61508, PL e according to 13849-1, and up to Cat. 4 according to EN 954-1
- Fail-safe I/O modules can be connected decentralized over the integrated PROFINET interface (PROFIsafe) and/or over the integrated PROFIBUS DP interface (PROFIsafe);
- Fail-safe I/O modules of ET200M can also be connected centrally
- Standard modules for non-safety-related applications can be operated centrally and decentralized
- Distributed intelligence in Component Based Automation (CBA) on PROFINET
- Isochronous mode on PROFIBUS
- PROFINET proxy for intelligent devices on PROFIBUS DP in Component based Automation (CBA)

SIMATIC Micro Memory Card required for operation of CPU.

Technical specifications

	6ES7 315-6FF04-0AB0	6ES7 315-2FJ14-0AB0	6ES7 317-6FF04-0AB0	6ES7 317-2FK14-0AB0	6ES7 318-3FL01-0AB0
General information Engineering with • Programming package	STEP 7 V5.5 + SP1 or higher or STEP7 V5.2 + SP1 or higher with HSP 218 + Distributed Safety	STEP 7 V 5.5 or higher, Distributed Safety V 5.4 SP4	STEP 7 V5.5 + SP1 or higher or STEP7 V5.2 + SP1 or higher with HSP 202 + Distributed Safety	STEP 7 V 5.5 or higher, Distributed Safety V 5.4 SP4	STEP 7 V 5.5 or higher, Distributed Safety V 5.4 SP4
Supply voltage 24 V DC	Yes	Yes	Yes	Yes	Yes
Power losses Power loss, typ.	4.5 W	4.65 W	4.5 W	4.65 W	14 W
Memory Work memory • integrated • Size of retentive memory for retentive data blocks	384 kbyte 128 kbyte	512 kbyte 128 kbyte	1 536 kbyte 256 kbyte	1 536 kbyte 256 kbyte	2 560 kbyte 700 kbyte
Load memory • pluggable (MMC), max.	8 Mbyte	8 Mbyte	8 Mbyte	8 Mbyte	8 Mbyte
CPU processing times for bit operations, typ.	0.05 µs	0.05 µs	0.025 µs	0.025 µs	0.004 µs
for word operations, typ.	0.09 µs	0.09 µs	0.03 µs	0.03 µs	0.01 µs
for fixed point arithmetic, typ.	0.12 µs	0.12 µs	0.04 µs	0.04 µs	0.01 µs
for floating point arithmetic, typ.	0.45 µs	0.45 µs	0.16 µs	0.16 µs	0.04 µs
Counters, timers and their retentivity S7 counter • Number	256	256	512	512	2 048
IEC counter • present	Yes	Yes	Yes	Yes	Yes
S7 times • Number	256	256	512	512	2 048
IEC timer • present	Yes	Yes	Yes	Yes	Yes
Data areas and their retentivity Flag • Number, max.	2 048 byte	2 048 byte	4 096 byte	4 096 byte	8 192 byte
Address area I/O address area • Inputs • Outputs	2 048 byte 2 048 byte	2 048 byte 2 048 byte	8 192 byte 8 192 byte	8 192 byte 8 192 byte	8 192 byte 8 192 byte
Process image • Inputs, adjustable • Outputs, adjustable	2 048 byte 2 048 byte	2 048 byte 2 048 byte	8 192 byte 8 192 byte	8 192 byte 8 192 byte	8 192 byte 8 192 byte
Time of day Clock • Hardware clock (real-time clock)	Yes	Yes	Yes	Yes	Yes
Operating hours counter • Number	1	1	4	4	4

SIMATIC S7-300

Central processing units

Fail-safe CPUs

Technical specifications (continued)

	6ES7 315-6FF04-0AB0	6ES7 315-2FJ14-0AB0	6ES7 317-6FF04-0AB0	6ES7 317-2FK14-0AB0	6ES7 318-3FL01-0AB0
1st interface					
Type of interface	Integrated RS 485 interface	Integrated RS 485 interface	Integrated RS 485 interface	Integrated RS 485 interface	Integrated RS 485 interface
Physics	RS 485	RS 485	RS 485	RS 485	RS 485
Functionality					
• MPI	Yes	Yes	Yes	Yes	Yes
• DP master	No	Yes	Yes	Yes	Yes
• DP slave	No	Yes	Yes; A DP slave at both interfaces simultaneously is not possible	Yes	Yes; A DP slave at both interfaces simultaneously is not possible
• Point-to-point connection	No	No	No	No	No
DP master					
• Number of DP slaves, max.		124	124	124	124
2nd interface					
Type of interface	Integrated RS 485 interface	PROFINET	Integrated RS 485 interface	PROFINET	Integrated RS 485 interface
Physics	RS 485	Ethernet RJ45	RS 485	Ethernet RJ45	RS 485
Number of ports		2		2	
Functionality					
• MPI	No	No	No	No	No
• DP master	Yes	No	Yes	No	Yes
• DP slave	Yes	No	Yes; A DP slave at both interfaces simultaneously is not possible	No	Yes; A DP slave at both interfaces simultaneously is not possible
• PROFINET IO Controller		Yes; Also simultaneously with IO-Device functionality		Yes; Also simultaneously with IO-Device functionality	No
• PROFINET IO Device		Yes; Also simultaneously with IO Controller functionality		Yes; Also simultaneously with IO Controller functionality	No
• PROFINET CBA		Yes		Yes	No
DP master					
• Number of DP slaves, max.	124; Per station		124		124
PROFINET IO Controller					
• Max. number of connectable IO devices for RT		128		128	
• Number of IO devices with IRT and the option "high flexibility"		128		128	
• Number of IO Devices with IRT and the option "high performance", max.		64		64	
3rd interface					
Type of interface					PROFINET
Physics					Ethernet RJ45
Number of ports					2
Functionality					
• MPI					No
• DP master					No
• DP slave					No
• PROFINET IO Controller					Yes; Also simultaneously with I-Device functionality
• PROFINET IO Device					Yes; Also simultaneously with IO Controller functionality
• PROFINET CBA					Yes
PROFINET IO Controller					
• Max. number of connectable IO devices for RT					256
• Number of IO devices with IRT and the option "high flexibility"					256
• Number of IO Devices with IRT and the option "high performance", max.					64

Technical specifications (continued)

	6ES7 315-6FF04-0AB0	6ES7 315-2FJ14-0AB0	6ES7 317-6FF04-0AB0	6ES7 317-2FK14-0AB0	6ES7 318-3FL01-0AB0
Isochronous mode					
Isochronous operation (application synchronized up to terminal)	Yes	Yes; Via PROFIBUS DP or PROFINET interface		Yes; Via PROFIBUS DP or PROFINET interface	Yes; Via 2nd PROFIBUS DP or PROFINET interface
Communication functions					
PG/OP communication	Yes	Yes	Yes	Yes	Yes
Data record routing	Yes	Yes	Yes	Yes	Yes
Global data communication					
• supported	Yes	Yes	Yes	Yes	Yes
S7 basic communication					
• supported	Yes	Yes	Yes	Yes	Yes
S7 communication					
• supported	Yes	Yes	Yes	Yes	Yes
S5-compatible communication					
• supported	Yes; via CP and loadable FC	Yes; via CP and loadable FC	Yes; via CP and loadable FC	Yes; via CP and loadable FC	Yes; via CP and loadable FC
Open IE communication					
• TCP/IP		Yes; via integrated PROFINET interface and loadable FBs 8		Yes; via integrated PROFINET interface and loadable FBs 16	Yes; via integrated PROFINET interface and loadable FBs 32
- Number of connections, max.		8		16	32
• ISO-on-TCP (RFC1006)		Yes; via integrated PROFINET interface and loadable FBs 8		Yes; via integrated PROFINET interface and loadable FBs 16	Yes; via integrated PROFINET interface and loadable FBs 32
- Number of connections, max.		8		16	32
• UDP		Yes; via integrated PROFINET interface and loadable FBs 8		Yes; via integrated PROFINET interface and loadable FBs 16	Yes; via integrated PROFINET interface and loadable FBs 32
- Number of connections, max.		8		16	32
Web server					
• supported		Yes; only read function		Yes	Yes
Number of connections					
• overall	16	16	32	32	32
Ambient conditions					
Operating temperature					
• Min.	0 °C	0 °C	0 °C	0 °C	0 °C
• max.	60 °C	60 °C	60 °C	60 °C	60 °C
Configuration					
programming					
• Programming language					
- LAD	Yes	Yes	Yes	Yes	Yes
- FBD	Yes	Yes	Yes	Yes	Yes
- STL	Yes	Yes	Yes	Yes	Yes
- SCL	Yes	Yes	Yes	Yes	Yes
- CFC	Yes	Yes	Yes	Yes	Yes
- GRAPH	Yes	Yes	Yes	Yes	Yes
- HiGraph®	Yes	Yes	Yes	Yes	Yes
Know-how protection					
• User program protection/password protection	Yes	Yes	Yes	Yes	Yes
• Block encryption	Yes; With S7 block Privacy	Yes; With S7 block Privacy	Yes; With S7 block Privacy	Yes; With S7 block Privacy	Yes; With S7 block Privacy
Dimensions					
Width	40 mm	40 mm	40 mm	40 mm	120 mm
Height	125 mm	125 mm	125 mm	125 mm	125 mm
Depth	130 mm	130 mm	130 mm	130 mm	130 mm
Weight					
Weight, approx.	290 g	340 g	360 g	340 g	1 250 g

SIMATIC S7-300

Central processing units

Fail-safe CPUs

Ordering data	Order No.	Order No.
CPU 315F-2 DP CPU for SIMATIC S7-300F; 384 KB RAM, power supply 24 V DC, MPI, PROFIBUS DP master/slave interface, incl. slot number labels; MMC required	6ES7 315-6FF04-0AB0	
CPU 317F-2 DP Main memory 1.5 MB, power supply 24 V DC, MPI, PROFIBUS DP master/slave interface, MMC required	6ES7 317-6FF04-0AB0	
CPU 315F-2 PN/DP CPU for SIMATIC S7-300F; 512 KB main memory, 24 V DC power supply, MPI/PROFIBUS DP master/slave interface, Industrial Ethernet/PROFINET interface; incl. slot number labels; MMC required	6ES7 315-2FJ14-0AB0	
CPU 317F-2 PN/DP Main memory 1.5 MB, 24 V DC power supply, MPI/PROFIBUS DP master/slave interface, Industrial Ethernet/PROFINET interface; MMC required	6ES7 317-2FK14-0AB0	
CPU 319F-3 PN/DP Main memory 2.5 MB, power supply 24 V DC, combined MPI/PROFIBUS DP master/slave interface, PROFIBUS DP master/slave interface, Ethernet/PROFINET interface; MMC required	6ES7 318-3FL01-0AB0	
Distributed Safety V5.4 programming tool Task: Software for configuring fail-safe user programs for SIMATIC S7-300F, S7-400F, ET 200S Requirement: STEP 7 V5.3 SP3 and higher Floating license Floating license for 1 user, license key download without software or documentation ¹⁾ ; email address required for delivery	6ES7 833-1FC02-0YA5 6ES7 833-1FC02-0YH5	
Distributed Safety Upgrade From V5.x to V5.4; Floating license for 1 user	6ES7 833-1FC02-0YE5	
STEP 7 Safety Advanced V11 Task: Engineering tool for configuring fail-safe user programs for SIMATIC S7-300F, S7-400F, WinAC RTX F, ET 200S, ET 200M, ET 200iSP, ET 200pro, ET 200eco Requirement: STEP 7 Professional V11 SP1 Floating license for 1 user Floating license for 1 user, license key download without software or documentation ¹⁾ ; email address required for delivery	6ES7 833-1FA11-0YA5 6ES7 833-1FA11-0YH5	
STEP 7 Safety Advanced Upgrade Distributed Safety V5.4 SP5 and STEP 7 Safety Advanced V11 for parallel use; incl. software on CD; Combo License for 1 user Distributed Safety V5.4 SP5 and STEP 7 Safety Advanced V11 for parallel use; includes software on CD; combo license for 1 user, license key download without software or documentation ¹⁾ ; email address required for delivery		6ES7 833-1FA11-0YE5 6ES7 833-1FA11-0YK5
SIMATIC Micro Memory Card 64 KB 128 KB 512 KB 2 MB 4 MB 8 MB		6ES7 953-8LF20-0AA0 6ES7 953-8LG20-0AA0 6ES7 953-8LJ30-0AA0 6ES7 953-8LL31-0AA0 6ES7 953-8LM20-0AA0 6ES7 953-8LP20-0AA0
MPI cable for connection of SIMATIC S7 and PG via MPI; 5 m in length		6ES7 901-0BF00-0AA0
Slot number plates		6ES7 912-0AA00-0AA0
S7-300 manual Design, CPU data, module data, instruction list German English		6ES7 398-8FA10-8AA0 6ES7 398-8FA10-8BA0
SIMATIC Manual Collection Electronic manuals on DVD, multilingual: LOGO1, SIMADYN, SIMATIC bus components, SIMATIC C7, SIMATIC distributed I/O, SIMATIC HMI, SIMATIC Sensors, SIMATIC NET, SIMATIC PC Based Automation, SIMATIC PCS 7, SIMATIC PG/PC, SIMATIC S7, SIMATIC Software, SIMATIC TDC		6ES7 998-8XC01-8YE0
SIMATIC Manual Collection update service for 1 year Current "Manual Collection" DVD and the three subsequent updates		6ES7 998-8XC01-8YE2
Power supply connector 10 units, spare part		6ES7 391-1AA00-0AA0
PC adapter USB A2 For connecting a PG/PC or notebook to PROFIBUS or MPI; USB cable included in scope of delivery		6GK1 571-0BA00-0AA0

¹⁾ For up-to-date information and download availability, see: www.siemens.com/tia-online-software-delivery

Ordering data	Order No.	Order No.	
PROFIBUS bus components PROFIBUS DP bus connector RS 485 <ul style="list-style-type: none"> with 90° cable outlet, max. transfer rate 12 Mbit/s <ul style="list-style-type: none"> without PG interface with PG interface with 90° cable outlet for FastConnect connection system, max. transfer rate 12 Mbit/s <ul style="list-style-type: none"> without PG interface, 1 unit without PG interface, 100 units with PG interface, 1 unit with PG interface, 100 units with axial cable outlet for SIMATIC OP, for connecting to PPI, MPI, PROFIBUS 	6ES7 972-0BA12-0XA0 6ES7 972-0BB12-0XA0 6ES7 972-0BA52-0XA0 6ES7 972-0BA52-0XB0 6ES7 972-0BB52-0XA0 6ES7 972-0BB52-0XB0 6GK1 500-0EA02	PROFINET bus components IE FC TP Standard Cable GP 2x2 4-core, shielded TP installation cable for connection to IE FC Outlet RJ45/ IE FC RJ45 Plug; PROFINET-compatible; with UL approval; sold by the meter FO Standard Cable GP (50/125) Standard cable, splittable, UL approval, sold by the meter SCALANCE X204-2 Industrial Ethernet Switch Industrial Ethernet Switches with integral SNMP access, web diagnostics, copper cable diagnostics and PROFINET diagnostics for configuring line, star and ring topologies; four 10/100 Mbit/s RJ45 ports and two FO ports CSM 377 Compact Switch Module Unmanaged switch for connecting a SIMATIC S7-300, ET200 M and up to three other stations to Industrial Ethernet with 10/100 Mbit/s; 4 x RJ45 ports; external 24 V DC power supply, LED diagnostics, S7-300 module incl. electronic manual on CD-ROM IE FC RJ45 plugs RJ45 plug connector for Industrial Ethernet with a rugged metal enclosure and integrated insulation displacement contacts for connecting Industrial Ethernet FC installation cables IE FC RJ45 plug 145 145° cable outlet 1 unit 10 units 50 units IE FC RJ45 plug 180 180° cable outlet 1 unit 10 units 50 units PROFIBUS/PROFINET bus components For establishing MPI/PROFIBUS/PROFINET communication	6XV1 840-2AH10 6XV1 873-2A 6GK5 204-2BB10-2AA3 6GK7 377-1AA00-0AA0 6GK1 901-1BB30-0AA0 6GK1 901-1BB30-0AB0 6GK1 901-1BB30-0AE0 6GK1 901-1BB10-2AA0 6GK1 901-1BB10-2AB0 6GK1 901-1BB10-2AE0 See catalogs IK PI, CA 01
PROFIBUS Fast Connect bus cable Standard type with special design for quick mounting, 2-core, shielded, sold by the meter, max. delivery unit 1000 m, minimum ordering quantity 20 m	6XV1 830-0EH10		
RS 485 repeater for PROFIBUS Transmission rate up to 12 Mbit/s; 24 V DC; IP20 enclosure	6ES7 972-0AA02-0XA0		

SIMATIC S7-300

Central processing units

SIPLUS fail-safe CPUs

Overview SIPLUS CPU 315F-2 DP



- For configuring a fail-safe automation system for plants with increased safety requirements
- Complies with safety requirements up to SIL 3 according to IEC 61508 and up to Cat. 4 according to EN 954-1
- Distributed fail-safe I/O modules can be connected through the integral PROFIBUS DP interface (PROFIsafe)
- The fail-safe I/O modules of ET 200M can be also centrally connected
- The standard modules for non-safety applications can be operated both centrally and locally

Micro Memory Card required for CPU operation.

Note:

SIPLUS extreme products are based on Siemens Industry standard products. The contents listed here were taken from the respective standard products. SIPLUS extreme-specific information was added.

	SIPLUS CPU 315F-2 DP	SIPLUS CPU 315F-2 DP (EN 50155)
Order number	6AG1 315-6FF04-2AB0	6AG1 315-6FF04-2AY0
Order number based on	6ES7 315-6FF04-0AB0	6ES7 315-6FF04-0AB0
Ambient temperature range	-25 ... +60 °C	
Conformal coating	Coating of the printed circuit boards and the electronic components	
Technical data	The technical data of the standard product applies except for the ambient conditions.	
Compliant with the standards for electronic equipment used on rolling stock (EN 50155, temperature T1, category 1).	No	Yes

Ambient conditions

Relative humidity 100%, condensation/frost permissible. No commissioning if condensation present.

For further technical documentation on SIPLUS, see:
www.siemens.com/siplus-extreme

Ordering data

Order No.

SIPLUS CPU 315F-2 DP

(extended temperature range and medial exposure)

CPU for SIPLUS S7-300F;
 384 KB work memory, 24 V DC supply voltage, MPI, PROFIBUS DP master/slave interface, incl. slot number labels; MMC required

Additional conformance with EN 50155

6AG1 315-6FF04-2AB0

6AG1 315-6FF04-2AY0

Accessories

See SIMATIC CPU 315F-2 DP, page 5/38

Overview SIPLUS CPU 315F-2 PN/DP



- The CPU with a medium sized program memory and quantity structures to build a fail-safe automation system for plants with increased safety requirements
- Complies with safety requirements up to SIL 3 according to IEC 61508, PL e in accordance with ISO 13849 and up to category 4 of EN 954-1
- The fail-safe I/O modules can be locally connected to the integrated PROFINET interface (PROFIsafe) and/or to the integrated PROFIBUS DP interface (PROFIsafe)
- The fail-safe I/O modules of ET 200M can be also centrally connected
- The standard modules for non-safety applications can be operated both centrally and locally
- Component based Automation (CBA) on PROFINET
- PROFINET IO Controller for operating distributed I/O on PROFINET
- PROFINET interface with 2-port switch
- PROFINET proxy for intelligent devices on PROFIBUS DP in Component based Automation (CBA)

Micro Memory Card required for operation of CPU.

Note:

SIPLUS extreme products are based on Siemens Industry standard products. The contents listed here were taken from the respective standard products. SIPLUS extreme-specific information was added.

SIPLUS CPU 315F-2 PN/DP		
Order No.	6AG1 315-2FJ14-2AB0	6AG1 315-2FJ14-2AY0
Order No. based on	6ES7 315-2FJ14-0AB0	6ES7 315-2FJ14-0AB0
Ambient temperature range	-25 ... +60 °C	
Conformal coating	Coating of the printed circuit boards and the electronic components	
Technical data	The technical data of the standard product applies except for the ambient conditions.	
Compliant with the standards for electronic equipment used on railway rolling stock (EN 50155, temperature T1, category 1).	No	Yes

Ambient conditions

Relative humidity 100%, condensation/frost permissible. No commissioning if condensation present.

Technical documentation on SIPLUS can be found here:

www.siemens.com/siplus-extreme

Ordering data

Ordering data	Order No.
CPU 315F-2 PN/DP	
CPU for SIPLUS S7-300F; work memory 512 KB, power supply 24 V DC, MPI/PROFIBUS DP master/slave interface, Industrial Ethernet/PROFINET interface; incl. slot number labels	6AG1 315-2FJ14-2AB0
Additional conformance with EN 50155	6AG1 315-2FJ14-2AY0
Accessories	See SIMATIC CPU 315F-2 PN/DP, page 5/38

SIMATIC S7-300

Central processing units

SIPLUS fail-safe CPUs

Overview SIPLUS CPU 317F-2 DP



- The fail-safe CPU with a large program memory and quantity framework for demanding applications
- For configuring a fail-safe automation system for plants with increased safety requirements
- Complies with safety requirements up to SIL 3 according to IEC 61508 and up to Cat. 4 according to EN 954-1
- Fail-safe I/O modules can be connected in a distributed configuration to both integral PROFIBUS DP interfaces (PROFIsafe)
- The fail-safe I/O modules of ET 200M can be also centrally connected
- The standard modules for non-safety applications can be operated both centrally and locally

Micro Memory Card required for operation of CPU.

Note:

SIPLUS extreme products are based on Siemens Industry standard products. The contents listed here were taken from the respective standard products. SIPLUS extreme-specific information was added.

SIPLUS CPU 317F-2 DP	
Order No.	6AG1 317-6FF04-2AB0
Order No. based on	6ES7 317-6FF04-0AB0
Ambient temperature range	-25 ... +60 °C
Conformal coating	Coating of the printed circuit boards and the electronic components.
Technical data	The technical data of the standard product applies except for the ambient conditions.
Compliant with the standards for electronic equipment used on rolling stock (EN 50155, temperature T1, category 1).	No
Technical data	The technical data are identical with those of the based-on modules.

Ambient conditions

Relative humidity	100%, condensation/frost permissible. No commissioning if condensation present.
-------------------	---

Technical documentation on SIPLUS can be found here:
www.siemens.com/siplus-extreme

Ordering data

Order No.

SIPLUS CPU 317F-2 DP

(extended temperature range and medial exposure)

Main memory 1.5 MB, power supply 24 V DC, MPI, PROFIBUS DP master/slave interface; MMC required

6AG1 317-6FF04-2AB0

Accessories

See SIMATIC CPU 317F-2 DP, page 5/38

Overview SIPLUS CPU 317F-2 PN/DP



- The failsafe CPU with a large program memory and quantity structures for demanding applications to build a fail-safe automation system for plants with increased safety requirements
- Complies with safety requirements up to SIL 3 according to IEC 61508, PL e in accordance with ISO 13849-1 and up to category 4 of EN 954-1
- The fail-safe I/O modules can be locally connected via the integrated PROFINET interface (PROFIsafe) and/or via the integrated PROFIBUS DP interface (PROFIsafe)
- The fail-safe I/O modules of ET 200M can be also centrally connected
- The standard modules for non-safety applications can be operated both centrally and locally
- Component Based Automation (CBA) on PROFINET
- PROFINET IO Controller for operating distributed I/O on PROFINET
- PROFINET interface with 2-port switch
- PROFINET proxy for intelligent devices on PROFIBUS DP in Component Based Automation (CBA)

SIMATIC Micro Memory Card required for operation of the CPU.

Note:

SIPLUS extreme products are based on Siemens Industry standard products. The contents listed here were taken from the respective standard products. SIPLUS extreme-specific information was added.

SIPLUS CPU 317F-2 PN/DP		
Order No.	6AG1 317-2FK14-2AB0	6AG1 317-2FK14-2AY0
Order number based on	6ES7 317-2FK14-0AB0	6ES7 317-2FK14-0AB0
Ambient temperature range	-25 ... +60 °C	
Conformal coating	Coating of the printed circuit boards and the electronic components	
Technical data	The technical data of the standard product applies except for the ambient conditions.	
Compliant with the standards for electronic equipment used on rolling stock (EN 50155, temperature T1, category 1).	No	Yes

Ambient conditions

Relative humidity 100%, condensation/frost permissible. No commissioning if condensation present.

Technical documentation on SIPLUS can be found here:
www.siemens.com/siplus-extreme

Ordering data	Order No.
SIPLUS CPU 317F-2 PN/DP (extended temperature range and medial exposure) Main memory 1.5 MB, power supply 24 V DC, MPI/PROFIBUS DP master/slave interface; Industrial Ethernet/PROFINET interface; MMC required Additional conformance with EN 50155	6AG1 317-2FK14-2AB0 6AG1 317-2FK14-2AY0
Accessories	See SIMATIC CPU 317F-2 PN/DP, page 5/38

SIMATIC S7-300

Central processing units

Technology CPUs

Overview CPU 315T-2 DP



- SIMATIC CPU with integral Technology/Motion Control functionality
- With full standard CPU 315-2 DP functionality
- For cross-industry automation tasks in series machine, special machine and plant construction
- Ideal for synchronized motion, such as coupling to a virtual/real master, gear synchronization, cam disk or print mark compensation
- 3D path interpolation with standard kinematics
- Position and pressure-regulated hydraulic axes
- Used as central controller in production lines with central and distributed I/O
- With integrated I/O for high-speed technology functions (e.g. camming, reference point acquisition)
- PROFIBUS DP (DRIVE) interface for isochronous connection of drive components
- One common S7 user program for control and motion control tasks (no additional programming language necessary for motion control)
- "S7-Technology" option package required

SIMATIC Micro Memory Card (8 MB) required for operation of the CPU.

Overview CPU 317T-2 DP



- SIMATIC CPU with integral Technology/Motion Control functionality
- With full standard CPU 317-2 DP functionality
- For cross-industry automation tasks in series machine, special machine and plant construction
- Ideal for synchronized motion, such as coupling to a virtual/real master, gear synchronization, cam disk, path interpolation, or print mark compensation
- 3D path interpolation with different kinematics
- Position and pressure-regulated hydraulic axes
- Used as central controller in production lines with central and distributed I/O
- Distributed intelligence in Component Based Automation (CBA) on PROFIBUS DP
- With integrated I/O for high-speed technology functions (e.g. camming, reference point acquisition)
- PROFIBUS DP (DRIVE) interface for isochronous connection of drive components
- One common S7 user program for control and motion control tasks (no additional programming language necessary for motion control)
- "S7-Technology" option package required

SIMATIC Micro Memory Card (8 MB) required for operation of the CPU.

Overview CPU 317TF-2 DP



- Failsafe SIMATIC CPU with integral Technology/Motion Control functionality
- With full functionality of the standard CPU 317-2 DP and CPU 317F-2 DP
- For cross-industry automation tasks in series machine, special machine and plant construction
- Ideal for synchronized motion, such as coupling to a virtual/real master, gear synchronization, cam disk, path interpolation, or print mark compensation
- 3D path interpolation with different kinematics
- Used as central controller in production lines with central and distributed I/O
- Distributed intelligence in Component Based Automation (CBA) on PROFIBUS DP
- With integrated I/O for high-speed technology functions (e.g. camming, reference point acquisition)
- PROFIBUS DP (DRIVE) interface for isochronous connection of drive components
- One common S7 user program for control and motion control tasks (no additional programming language necessary for motion control)
- "S7-Technology" option package required
- "S7 Distributed Safety" option package required

SIMATIC Micro Memory Card (8 MB) required for operation of the CPU.

Technical specifications

	6ES7 315-6TH13-0AB0	6ES7 317-6TK13-0AB0	6ES7 317-6TF14-0AB0
General information Engineering with • Programming package	STEP 7 V5.4 + SP5 (and higher) and Optional package S7-Technology V4.2	STEP 7 V5.4 + SP5 (and higher) and Optional package S7-Technology V4.2	STEP7 V 5.4 SP5 or higher, S7-Technology V4.2 or higher, Distributed Safety V5.4 SP5 or higher, S7-F Configuration Pack V5.5 SP7 or higher
Supply voltage 24 V DC	Yes	Yes	Yes
Power losses Power loss, typ.	6 W	6 W	6 W
Memory Work memory • integrated • Size of retentive memory for retentive data blocks	256 kbyte	1 024 kbyte	1 536 kbyte 256 kbyte
Load memory • pluggable (MMC), max.	8 Mbyte	8 Mbyte	8 Mbyte
CPU processing times for bit operations, typ.	0.1 µs	0.05 µs	0.05 µs
for word operations, typ.	0.2 µs	0.2 µs	0.2 µs
for fixed point arithmetic, typ.	2 µs	0.2 µs	0.2 µs
for floating point arithmetic, typ.	3 µs	1 µs	1 µs
Counters, timers and their retentivity S7 counter • Number	256; Number range: 0 to 255	512; Number range: 0 to 511	512; Number range: 0 to 511
IEC counter • present	Yes	Yes	Yes
S7 times • Number	256; Number range: 0 to 255	512; Number range: 0 to 511	512; Number range: 0 to 511
IEC timer • present	Yes	Yes	Yes

SIMATIC S7-300

Central processing units

Technology CPUs

Technical specifications (continued)

	6ES7 315-6TH13-0AB0	6ES7 317-6TK13-0AB0	6ES7 317-6TF14-0AB0
Data areas and their retentivity			
Flag			
• Number, max.	2 048 byte	4 096 byte	4 096 byte
Address area			
I/O address area			
• Inputs	2 048 byte	8 192 byte	8 192 byte
• Outputs	2 048 byte	8 192 byte	8 192 byte
Process image			
• Inputs, adjustable	2 048 byte	2 048 byte	2 048 byte
• Outputs, adjustable	2 048 byte	2 048 byte	2 048 byte
Time of day			
Clock			
• Hardware clock (real-time clock)	Yes	Yes	Yes
Operating hours counter			
• Number	1	4	4
1st interface			
Type of interface	Integrated RS 485 interface	Integrated RS 485 interface	Integrated RS 485 interface
Physics	RS 485	RS 485	RS 485
Functionality			
• MPI	Yes	Yes	Yes
• DP master	Yes	Yes	Yes
• DP slave	Yes	Yes	Yes
• Point-to-point connection	No	No	No
DP master			
• Number of DP slaves, max.	124	124	124
2nd interface			
Type of interface	Integrated RS 485 interface	Integrated RS 485 interface	Integrated RS 485 interface
Physics	RS 485	RS 485	RS 485
Functionality			
• MPI	No	No	No
• DP master	Yes; DP(DRIVE)-Master	Yes; DP(DRIVE)-Master	Yes; DP(DRIVE)-Master
• DP slave	No	No	No
DP master			
• Number of DP slaves, max.	64	64	64
Communication functions			
PG/OP communication	Yes	Yes	Yes
Global data communication			
• supported	Yes	Yes	Yes
S7 basic communication			
• supported	Yes	Yes	Yes
S7 communication			
• supported	Yes	Yes	Yes
S5-compatible communication			
• supported	Yes; via CP and loadable FC	Yes; via CP and loadable FC	Yes; via CP and loadable FC
Number of connections			
• overall	16	32	32
Ambient conditions			
Operating temperature			
• Min.	0 °C	0 °C	0 °C
• max.	60 °C	60 °C	60 °C

Technical specifications (continued)

	6ES7 315-6TH13-0AB0	6ES7 317-6TK13-0AB0	6ES7 317-6TF14-0AB0
Configuration			
programming			
• Programming language			
- LAD	Yes	Yes	Yes
- FBD	Yes	Yes	Yes
- STL	Yes	Yes	Yes
- SCL	Yes	Yes	Yes
- CFC	Yes	Yes	Yes
- GRAPH	Yes	Yes	Yes
- HiGraph®	Yes	Yes	Yes
Know-how protection			
• User program protection/password protection	Yes	Yes	Yes
Dimensions			
Width	160 mm	160 mm	160 mm
Height	125 mm	125 mm	125 mm
Depth	130 mm	130 mm	130 mm
Weight			
Weight, approx.	750 g	750 g	750 g

Ordering data

	Order No.		Order No.
CPU 315T-2 DP	6ES7 315-6TH13-0AB0	SIMATIC Micro Memory Card	
256 KB main memory, 24 V DC power supply, MPI, PROFIBUS DP master/slave interface, PROFIBUS DP(DRIVE) interface; with technology/motion control functions; MMC required		4 MB	6ES7 953-8LM20-0AA0
		8 MB	6ES7 953-8LP20-0AA0
		MPI cable	6ES7 901-0BF00-0AA0
		for connection of SIMATIC S7 and PG via MPI; 5 m in length	
CPU 317T-2 DP	6ES7 317-6TK13-0AB0	Front connector (1 unit)	
1024 KB main memory, 24 V DC power supply, MPI, PROFIBUS DP master/slave interface, PROFIBUS DP (DRIVE) interface; with technology/motion control functions; MMC required		40-pin, with screw contacts	
		• 1 unit	6ES7 392-1AM00-0AA0
		• 100 units	6ES7 392-1AM00-1AB0
		40-pin, with spring-loaded contacts	
		• 1 unit	6ES7 392-1BM01-0AA0
		• 100 units	6ES7 392-1BM01-1AB0
CPU 317TF-2 DP	6ES7 317-6TF14-0AB0	Slot number plates	6ES7 912-0AA00-0AA0
1.5 MB main memory, 24 V DC power supply, MPI, PROFIBUS DP master/slave interface, PROFIBUS DP(DRIVE) interface; with technology/motion control functions; MMC required		S7-300 manual	
		Design, CPU data, module data, instruction list	
		German	6ES7 398-8FA10-8AA0
		English	6ES7 398-8FA10-8BA0
S7-Technology V4.2	6ES7 864-1CC42-0YA5	SIMATIC Manual Collection	6ES7 998-8XC01-8YE0
Task: Option package for configuring and programming technology tasks with SIMATIC S7 CPU 31xT-2 DP and the SIMATIC S7 CPU 317TF-2 DP Requirement: STEP 7 V5.4 SP5 or higher Delivery package: on DVD; incl. documentation for CPU 31xT-2 DP, CPU 317TF-2 DP (included on DVD)		Electronic manuals on DVD, multilingual: LOGO!, SIMADYN, SIMATIC bus components, SIMATIC C7, SIMATIC distributed I/O, SIMATIC HMI, SIMATIC Sensors, SIMATIC NET, SIMATIC PC Based Automation, SIMATIC PCS 7, SIMATIC PG/PC, SIMATIC S7, SIMATIC Software, SIMATIC TDC	
		SIMATIC Manual Collection update service for 1 year	6ES7 998-8XC01-8YE2
		Current "Manual Collection" DVD and the three subsequent updates	

SIMATIC S7-300

Central processing units

Technology CPUs

Ordering data	Order No.	Order No.
Power supply connector 10 units, spare part	6ES7 391-1AA00-0AA0	
Labeling strips 10 units, spare part	6ES7 392-2XX00-0AA0	
Label cover 10 units, spare part	6ES7 392-2XY00-0AA0	
Labeling sheets for machine inscription For 32-channel signal modules, DIN A4, for printing with laser printer; 10 units petrol light-beige yellow red	6ES7 392-2AX10-0AA0 6ES7 392-2BX10-0AA0 6ES7 392-2CX10-0AA0 6ES7 392-2DX10-0AA0	
PC adapter USB A2 for connecting a PG/PC or notebook to PROFIBUS or MPI, USB cable included in scope of supply	6GK1 571-0BA00-0AA0	
PROFIBUS DP bus connector RS 485 • With 90° cable outlet, max. transfer rate 12 Mbit/s - Without PG interface - With PG interface • With 90° cable outlet for FastConnect connection system, max. transfer rate 12 Mbit/s - Without PG interface, 1 unit - Without PG interface, 100 units - With PG interface, 1 unit - With PG interface, 100 units • With axial cable outlet for SIMATIC OP, for connecting to PPI, MPI, PROFIBUS	6ES7 972-0BA12-0XA0 6ES7 972-0BB12-0XA0 6ES7 972-0BA52-0XA0 6ES7 972-0BA52-0XB0 6ES7 972-0BB52-0XA0 6ES7 972-0BB52-0XB0 6GK1 500-0EA02	
		PROFIBUS Fast Connect bus cable Standard type with special design for quick mounting, 2-core, shielded, sold by the meter, max. delivery unit 1000 m, minimum ordering quantity 20 m
		6XV1 830-0EH10
		RS 485 repeater for PROFIBUS Transmission rate up to 12 Mbit/s; 24 V DC; IP20 enclosure
		6ES7 972-0AA02-0XA0
		PROFIBUS bus components For establishing MPI/PROFIBUS communication
		See catalogs IK PI, CA 01

Overview



- Digital inputs
- For connecting standard switches and two-wire proximity switches

Technical specifications

	6ES7 321-1BH02-0AA0	6ES7 321-1BH50-0AA0	6ES7 321-1BL00-0AA0	6ES7 321-1BP00-0AA0	6ES7 321-1BH10-0AA0
Supply voltage					
Load voltage L+					
• Rated value (DC)	24 V	24 V	24 V	24 V	24 V
Input current					
from backplane bus 5 V DC, max.	10 mA	10 mA	15 mA	100 mA	110 mA
Power losses					
Power loss, typ.	3.5 W	3.5 W	6.5 W	7 W	3.8 W
Digital inputs					
Number/binary inputs	16	16	32	64	16
Input characteristic curve acc. to IEC 61131, Type 1	Yes	Yes	Yes	Yes	Yes
Number of simultaneously controllable inputs					
• horizontal installation					
- up to 40 °C, max.	16	16	32	64	16
- up to 60 °C, max.	16	16	16	32	16
• vertical installation					
- up to 40 °C, max.	16	16	32	32	16
Input voltage					
• Type of input voltage	DC	DC	DC	DC	DC
• Rated value, DC	24 V	24 V	24 V	24 V	24 V
• for signal "0"	-30 to +5 V	-5 to +30 V	-30 to +5 V	-30 to +5 V	-30 to +5 V
• for signal "1"	13 to 30 V	-13 to -30 V	13 to 30 V	13 to 30 V	13 to 30 V
Input current					
• for signal "1", typ.	7 mA	7 mA	7 mA	4.2 mA; Typical	7 mA
Input delay (for rated value of input voltage)					
• for standard inputs					
- Parameterizable	No	No	No	No	No
- at "0" to "1", min.	1.2 ms	1.2 ms	1.2 ms	1.2 ms	25 µs
- at "0" to "1", max.	4.8 ms	4.8 ms	4.8 ms	4.8 ms	75 µs
Cable length					
• Cable length, shielded, max.	1 000 m	1 000 m	1 000 m	1 000 m	1 000 m
• Cable length unshielded, max.	600 m	600 m	600 m	600 m	600 m
Encoder					
Connectable encoders					
• 2-wire sensor	Yes	Yes	Yes	No	Yes
- Permissible quiescent current (2-wire sensor), max.	1.5 mA	1.5 mA	1.5 mA		1.5 mA
Isochronous mode					
Isochronous operation (application synchronized up to terminal)	No	No	No	No	Yes

SIMATIC S7-300

Digital modules

SM 321 digital input modules

Technical specifications (continued)

	6ES7 321-1BH02-0AA0	6ES7 321-1BH50-0AA0	6ES7 321-1BL00-0AA0	6ES7 321-1BP00-0AA0	6ES7 321-1BH10-0AA0
Interrupts/diagnostics/status information					
Alarms					
• Alarms	No	No	No	No	No
• Diagnostic alarm	No	No	No	No	No
• Hardware interrupt	No	No	No	No	No
Diagnostic messages					
• Diagnostic functions	No	No	No	No	No
Diagnostics indication LED					
• Status indicator digital input (green)	Yes	Yes	Yes	Yes	Yes
Galvanic isolation					
Galvanic isolation digital inputs					
• between the channels	No	No	No	No	No
• between the channels, in groups of 16	16	16	16	16	16
• between the channels and the backplane bus	Yes; Optocoupler	Yes; Optocoupler	Yes; Optocoupler	Yes; Optocoupler	Yes; Optocoupler
Isolation					
Isolation checked with	500 V DC	500 V DC	500 V DC	500 V DC	500 V DC
Connection method					
required front connector	20-pin	20-pin	40-pin	Cable: 6ES7 392-4Bxx0-0AA0 terminal blocks: 6ES7 392-1xN00-0AA0	20-pin
Dimensions					
Width	40 mm	40 mm	40 mm	40 mm	40 mm
Height	125 mm	125 mm	125 mm	125 mm	125 mm
Depth	120 mm	120 mm	120 mm	112 mm	120 mm
Weight					
Weight, approx.	200 g	200 g	260 g	230 g; approx.	200 g
	6ES7 321-7BH01-0AB0	6ES7 321-1CH00-0AA0	6ES7 321-1CH20-0AA0	6ES7 321-1FH00-0AA0	
Supply voltage					
Load voltage L+					
• Rated value (DC)	24 V	24 V	48 V		
Load voltage L1					
• Rated value (AC)		24 V		230 V; 120/230 V AC; all load voltages must have the same phase.	
Input current					
from load voltage L+ (without load), max.	90 mA				
from backplane bus 5 V DC, max.	130 mA	100 mA	40 mA		29 mA
Power losses					
Power loss, typ.	4 W	1.5 W; at 24 V; 2.8 W at 48 V	4.3 W		4.9 W
Digital inputs					
Number/binary inputs	16	16	16		16
Input characteristic curve acc. to IEC 61131, Type 1		Yes	Yes		Yes
Input characteristic curve acc. to IEC 61131, Type 2	Yes				
Number of simultaneously controllable inputs					
• horizontal installation					
- up to 40 °C, max.	16	16	8		16
- up to 60 °C, max.	16	16	8; 6 to U_e 146 V		16
• vertical installation					
- up to 40 °C, max.	16	16	8		16

Technical specifications (continued)

	6ES7 321-7BH01-0AB0	6ES7 321-1CH00-0AA0	6ES7 321-1CH20-0AA0	6ES7 321-1FH00-0AA0
Input voltage • Type of input voltage • Rated value, AC • Rated value, DC • for signal "0" • for signal "1" • Frequency range	DC 24 V -30 to +5 V 13 to 30 V	AC/DC 24 V; AC 24 or 48 V 24 V; DC 24 or 48 V -5 to +5 V AC 14 to 60 V AC 0 to 63 Hz	DC 48 V; 48 to 125 V DC -146 to +15 V DC 30 to 146 V DC	AC 230 V; 120/230 V AC 0 to 40 V 79 to 264 V 47 to 63 Hz
Input current • for signal "1", typ.	7 mA	2.7 mA	3.5 mA	6.5 mA; (120V, 60Hz), 16mA (230V, 50Hz)
Input delay (for rated value of input voltage) • for standard inputs - Parameterizable - at "0" to "1", min. - at "0" to "1", max.	Yes; 0.1 / 0.5 / 3 / 15 / 20 ms	No 16 ms 16 ms	No 0.1 ms 3.5 ms	No 25 ms 25 ms
Cable length • Cable length, shielded, max. • Cable length unshielded, max.	1 000 m 600 m	1 000 m 600 m	1 000 m 600 m	1 000 m 600 m
Encoder Connectable encoders • 2-wire sensor - Permissible quiescent current (2-wire sensor), max.	Yes 2 mA	Yes 1 mA	Yes 1 mA	Yes 2 mA
Isochronous mode Isochronous operation (application synchronized up to terminal)	Yes	No	No	No
Interrupts/diagnostics/status information Alarms • Alarms • Diagnostic alarm • Hardware interrupt	Yes Yes; Parameterizable Yes; Parameterizable	No No No	No No No	No No No
Diagnostic messages • Diagnostic functions	Yes; Parameterizable	No	No	No
Diagnostics indication LED • Status indicator digital input (green)	Yes	Yes	Yes	Yes
Galvanic isolation Galvanic isolation digital inputs • between the channels • between the channels, in groups of • between the channels and the backplane bus	No 16 Yes; Optocoupler	Yes 1 Yes; Optocoupler	No 8 Yes; Optocoupler	No 4 Yes; Optocoupler
Isolation Isolation checked with	500 V DC	1500 V AC	1500 V DC	4000 VDC
Connection method required front connector	20-pin	40-pin	20-pin	20-pin
Dimensions Width Height Depth	40 mm 125 mm 120 mm	40 mm 125 mm 120 mm	40 mm 125 mm 120 mm	40 mm 125 mm 120 mm
Weight Weight, approx.	200 g	260 g	200 g	240 g

SIMATIC S7-300

Digital modules

SM 321 digital input modules

Technical specifications (continued)

	6ES7 321-1EL00-0AA0	6ES7 321-1FF01-0AA0	6ES7 321-1FF10-0AA0
Supply voltage			
Load voltage L1			
• Rated value (AC)	120 V	230 V; 120/230 V AC	230 V; 120/230 V AC; all load voltages must have the same phase.
Input current			
from backplane bus 5 V DC, max.	16 mA	29 mA	100 mA
Power losses			
Power loss, typ.	4 W	4.9 W	4.9 W
Digital inputs			
Number/binary inputs	32	8	8
Input characteristic curve acc. to IEC 61131, Type 1		Yes	Yes
Input characteristic curve acc. to IEC 61131, Type 2	Yes		
Number of simultaneously controllable inputs			
• horizontal installation			
- up to 40 °C, max.	32		
- up to 60 °C, max.	24	8	8
• vertical installation			
- up to 40 °C, max.	32	8	8
Input voltage			
• Type of input voltage	AC	AC	AC
• Rated value, AC	120 V	230 V; 120/230 V AC	120 V; 120/230 V AC
• for signal "0"	0 to 20 V	0 to 40 V	0 to 40 V
• for signal "1"	74 to 132 V	79 to 264 V	79 to 264 V
• Frequency range	47 to 63 Hz	47 to 63 Hz	47 to 63 Hz
Input current			
• for signal "1", typ.	21 mA	6.5 mA; (120 V); 11 mA (230 V)	7.5 mA; (120 V); 17.3 mA (230 V)
Input delay (for rated value of input voltage)			
• for standard inputs			
- Parameterizable	No	No	No
- at "0" to "1", max.	15 ms	25 ms	25 ms
Cable length			
• Cable length, shielded, max.	1 000 m	1 000 m	1 000 m
• Cable length unshielded, max.	600 m	600 m	600 m
Encoder			
Connectable encoders			
• 2-wire sensor	Yes	Yes	Yes
- Permissible quiescent current (2-wire sensor), max.	4 mA	2 mA	2 mA
Isochronous mode			
Isochronous operation (application synchronized up to terminal)	No	No	No

Technical specifications (continued)

	6ES7 321-1EL00-0AA0	6ES7 321-1FF01-0AA0	6ES7 321-1FF10-0AA0
Interrupts/diagnostics/status information			
Alarms			
• Alarms	No	No	No
• Diagnostic alarm	No	No	No
• Hardware interrupt	No	No	No
Diagnostic messages			
• Diagnostic functions	No	No	No
Diagnostics indication LED			
• Status indicator digital input (green)	Yes; per channel	Yes	Yes
Galvanic isolation			
Galvanic isolation digital inputs			
• between the channels	No	No	Yes
• between the channels, in groups of 8	8	2	1
• between the channels and the backplane bus	Yes; Optocoupler	Yes; Optocoupler	Yes; Optocoupler
Isolation			
Isolation checked with	2500 V DC	4000 VDC	1500 V AC
Connection method			
required front connector	40-pin	20-pin	40-pin
Dimensions			
Width	40 mm	40 mm	40 mm
Height	125 mm	125 mm	125 mm
Depth	120 mm	120 mm	120 mm
Weight			
Weight, approx.	300 g	240 g	240 g

SIMATIC S7-300

Digital modules

SM 321 digital input modules

Ordering data

SM 321 digital input modules

incl. labeling strips, bus connector

16 inputs, 24 V DC

16 inputs, 24 V DC, active low

32 inputs, 24 V DC

64 inputs, 24 V DC, active high/low

Note:

6ES7392-4...0-0AA0 connection cable and 6ES7392-1.N00-0AA0 terminal blocks necessary.

16 inputs, 24 to 48 V DC

16 inputs, 48 to 125 V DC

16 inputs, 24 V DC, for isochronous mode

32 inputs, 120 V AC

8 inputs, 120/230 V AC

8 inputs, 120/230 V AC, single root

16 inputs, 120/230 V AC

16 inputs, 24 V DC, for isochronous mode, diagnostics-capable

Front connector

20-pin, with screw contacts

- 1 unit
- 100 units

20-pin, with spring-loaded contacts

- 1 unit
- 100 units

40-pin, with screw contacts

- 1 unit
- 100 units

40-pin, with spring-loaded contacts

- 1 unit
- 100 units

S7-300 connecting cable

for 64-channel modules; 2 units

1 m

2.5 m

5 m

Terminal block

for 64-channel modules; 2 units

with screw contacts

with spring-loaded contacts

Front door, elevated design

e.g. for 32-channel modules; for connecting 1.3 mm²/16 AWG conductors; circuit diagram and nameplates in petrol

Order No.

6ES7 321-1BH02-0AA0

6ES7 321-1BH50-0AA0

6ES7 321-1BL00-0AA0

6ES7 321-1BP00-0AA0

6ES7 321-1CH00-0AA0

6ES7 321-1CH20-0AA0

6ES7 321-1BH10-0AA0

6ES7 321-1EL00-0AA0

6ES7 321-1FF01-0AA0

6ES7 321-1FF10-0AA0

6ES7 321-1FH00-0AA0

6ES7 321-7BH01-0AB0

6ES7 392-1AJ00-0AA0

6ES7 392-1AJ00-1AB0

6ES7 392-1BJ00-0AA0

6ES7 392-1BJ00-1AB0

6ES7 392-1AM00-0AA0

6ES7 392-1AM00-1AB0

6ES7 392-1BM01-0AA0

6ES7 392-1BM01-1AB0

6ES7 392-4BB00-0AA0

6ES7 392-4BC50-0AA0

6ES7 392-4BF00-0AA0

6ES7 392-1AN00-0AA0

6ES7 392-1BN00-0AA0

6ES7 328-0AA00-7AA0

Order No.

SIMATIC TOP connect

See page 5/224; for information about which components can be used for the respective module, see Industry Mall

Bus connectors

1 unit (spare part)

6ES7 390-0AA00-0AA0

Labeling strips

10 units (spare part)

for modules with 20-pin front connector

6ES7 392-2XX00-0AA0

for modules with 40-pin front connector

6ES7 392-2XX10-0AA0

Label cover

10 units (spare part)

for modules with 20-pin front connector

6ES7 392-2XY00-0AA0

for modules with 40-pin front connector

6ES7 392-2XY10-0AA0

Labeling sheets for machine inscription

for modules with 20-pin front connector, DIN A4, for printing with laser printer; 10 units

petrol

6ES7 392-2AX00-0AA0

light-beige

6ES7 392-2BX00-0AA0

yellow

6ES7 392-2CX00-0AA0

red

6ES7 392-2DX00-0AA0

for modules with 40-pin front connector, DIN A4, for printing with laser printer; 10 units

petrol

6ES7 392-2AX10-0AA0

light-beige

6ES7 392-2BX10-0AA0

yellow

6ES7 392-2CX10-0AA0

red

6ES7 392-2DX10-0AA0

SIMATIC Manual Collection

6ES7 998-8XC01-8YE0

Electronic manuals on DVD, multilingual: LOGO!, SIMADYN, SIMATIC bus components, SIMATIC C7, SIMATIC distributed I/O, SIMATIC HMI, SIMATIC Sensors, SIMATIC NET, SIMATIC PC Based Automation, SIMATIC PCS 7, SIMATIC PG/PC, SIMATIC S7, SIMATIC Software, SIMATIC TDC

SIMATIC Manual Collection update service for 1 year

6ES7 998-8XC01-8YE2

Current "Manual Collection" DVD and the three subsequent updates

S7-300 manual

Design, CPU data, module data, instruction list

German

6ES7 398-8FA10-8AA0

English

6ES7 398-8FA10-8BA0

Overview



- Digital outputs
- For connecting solenoid valves, contactors, low-power motors, lamps and motor starters

Technical specifications

	6ES7 322-1BH01-0AA0	6ES7 322-1BH10-0AA0	6ES7 322-1BL00-0AA0	6ES7 322-1BP00-0AA0	6ES7 322-1BP50-0AA0	6ES7 322-8BF00-0AB0
Supply voltage						
Load voltage L+						
• Rated value (DC)	24 V	24 V	24 V	24 V	24 V	24 V
Input current						
from load voltage L+ (without load), max.	80 mA	110 mA	160 mA	75 mA	75 mA	90 mA
from backplane bus 5 V DC, max.	80 mA	70 mA	110 mA	100 mA	100 mA	70 mA
Power losses						
Power loss, typ.	4.9 W	5 W	6.6 W	6 W	6 W	5 W
Digital outputs						
Number/binary outputs	16	16	32	64	64	8
Limitation of inductive shutdown voltage to	L+ (-53 V)	L+ (-53 V)	L+ (-53 V)	L+ (-53 V)	M+ (45 V)	L+ (-45 V)
Lamp load, max.	5 W	5 W	5 W	5 W	5 W	5 W
Load resistance range						
• lower limit	48 Ω	48 Ω	48 Ω	80 Ω	80 Ω	48 Ω
• upper limit	4 kΩ	4 kΩ	4 kΩ	10 kΩ	10 kΩ	3 kΩ
Output voltage						
• for signal "1", min.	L+ (-0.8 V)	L+ (-0.8 V)	L+ (-0.8 V)	L+ (-0.5 V)	M+ (0.5 V)	L+ (-0.8 to -1.6 V)
Output current						
• for signal "1" rated value	0.5 A	0.5 A	0.5 A	0.3 A	0.3 A	0.5 A
• for signal "1" permissible range, min.				2.4 mA	2.4 mA	
• for signal "1" permissible range, max.				0.36 A	0.36 A	
• for signal "1" permissible range for 0 to 40 °C, min.	5 mA	5 mA	5 mA			10 mA
• for signal "1" permissible range for 0 to 40 °C, max.	0.6 A	0.6 A	0.6 A			0.6 A
• for signal "1" permissible range for 40 to 60 °C, min.	5 mA	5 mA	5 mA			10 mA
• for signal "1" permissible range for 40 to 60 °C, max.	0.6 A	0.6 A	0.6 A			0.6 A
• for signal "1" minimum load current	5 mA	5 mA	5 mA			10 mA
• for signal "0" residual current, max.	0.5 mA	0.5 mA	0.5 mA	0.1 mA		0.5 mA
Switching frequency						
• with resistive load, max.	100 Hz	1 000 Hz	100 Hz	100 Hz	100 Hz	100 Hz
• with inductive load, max.	0.5 Hz	0.5 Hz	0.5 Hz	0.5 Hz	0.5 Hz	2 Hz
• on lamp load, max.	10 Hz	10 Hz	10 Hz	10 Hz	10 Hz	10 Hz

SIMATIC S7-300

Digital modules

SM 322 digital output modules

Technical specifications (continued)

	6ES7 322-1BH01-0AA0	6ES7 322-1BH10-0AA0	6ES7 322-1BL00-0AA0	6ES7 322-1BP00-0AA0	6ES7 322-1BP50-0AA0	6ES7 322-8BF00-0AB0
Aggregate current of outputs (per group)						
• horizontal installation						
- up to 40 °C, max.	4 A	4 A	4 A	1.6 A	1.6 A	4 A
- up to 60 °C, max.	3 A	3 A	3 A	1.2 A	1.2 A	3 A
• vertical installation						
- up to 40 °C, max.	2 A	2 A	2 A	1.6 A	1.6 A	4 A
Total current of the outputs (per module)						
• horizontal installation						
- up to 60 °C, max.				4.8 A	4.8 A	
• all other mounting positions						
- up to 40 °C, max.				6.4 A	6.4 A	
Cable length						
• Cable length, shielded, max.	1 000 m	1 000 m	1 000 m	1 000 m	1 000 m	1 000 m
• Cable length unshielded, max.	600 m	600 m	600 m	600 m	600 m	600 m
Interrupts/diagnostics/status information						
Alarms						
• Diagnostic alarm	No	No	No	No	No	Yes; Parameterizable
Diagnostic messages						
• Diagnostics	No	No	No	No	No	Yes
Galvanic isolation						
Galvanic isolation digital outputs						
• between the channels, in groups of	8	8	8	16	16	8
• between the channels and the backplane bus	Yes; Optocoupler	Yes; Optocoupler	Yes; Optocoupler	Yes; Optocoupler	Yes; Optocoupler	Yes; Optocoupler
Isolation						
Isolation checked with	500 V DC	500 V DC	500 V DC	500 V DC	500 V DC	500 V DC
Connection method						
required front connector	20-pin	20-pin	40-pin	Cable: 6ES7 392-4Bxx0-0AA0 terminal blocks: 6ES7 392-1xN00-0AA0	Cable: 6ES7 392-4Bxx0-0AA0 terminal blocks: 6ES7 392-1xN00-0AA0	20-pin
Dimensions						
Width	40 mm	40 mm	40 mm	40 mm	40 mm	40 mm
Height	125 mm	125 mm	125 mm	125 mm	125 mm	125 mm
Depth	120 mm	120 mm	120 mm	112 mm	112 mm	120 mm
Weight						
Weight, approx.	190 g	200 g	260 g	230 g	230 g	210 g

Technical specifications (continued)

	6ES7 322-5GH00-0AB0	6ES7 322-1CF00-0AA0	6ES7 322-1BF01-0AA0	6ES7 322-1FF01-0AA0	6ES7 322-5FF00-0AB0	6ES7 322-1FH00-0AA0
Supply voltage						
Load voltage L+						
• Rated value (DC)	24 V; 24 / 48	48 V; 48 to 125 V DC	24 V			
Load voltage L1						
• Rated value (AC)				230 V; 120/230 V AC	230 V; 120/230 V AC	230 V; 120/230 V AC
Input current						
from load voltage L+ (without load), max.	200 mA	2 mA	60 mA			2 mA
from load voltage L1 (without load), max.				2 mA	2 mA	3 mA
from backplane bus 5 V DC, max.	100 mA	100 mA	40 mA	100 mA	100 mA	200 mA
Power losses						
Power loss, typ.	2.8 W	7.2 W	6.8 W	8.6 W	8.6 W	8.6 W
Digital outputs						
Number/binary outputs	16	8	8	8	8	16
Limitation of inductive shutdown voltage to		M (-1 V)	L+ (-48 V)			
Lamp load, max.	2.5 W	15 W; 15 W (48 V) or 40 W (125 V)	10 W	50 W	50 W	50 W
Load resistance range						
• lower limit			12 Ω			
• upper limit			4 kΩ			
Output voltage						
• for signal "1", min.	L+ (-0.25 V)	L+ (-1.2 V)	L+ (-0.8 V)	L1 (-1.5 V)	L1 (-8.5 V)	
Output current						
• for signal "1" rated value	0.5 A	1.5 A	2 A	2 A	2 A	1 A
• for signal "1" permissible range for 0 to 40 °C, min.		10 mA	5 mA	10 mA	10 mA	10 mA
• for signal "1" permissible range for 0 to 40 °C, max.	0.5 A	1.5 A	2.4 A	2 A	2 A	1 A
• for signal "1" permissible range for 40 to 60 °C, min.		10 mA	5 mA	10 mA	10 mA	10 mA
• for signal "1" permissible range for 40 to 60 °C, max.	0.5 A	1.5 A	2.4 A	1 A	1 A	0.5 A
• for signal "1" minimum load current		10 mA	5 mA	10 mA	10 mA	10 mA
• for signal "1" permissible surge current, max.	1.5 A; for 50 ms, 1 A 2 s one-time	3 A; for 10 ms		20 A; max. 1 AC cycle	20 A; with 2 half waves	20 A; with 2 half waves
• for signal "0" residual current, max.	10 μA	0.5 mA	0.5 mA	2 mA	2 mA	2 mA
Switching frequency						
• with resistive load, max.	10 Hz	25 Hz	100 Hz	10 Hz	10 Hz	10 Hz
• with inductive load, max.	0.5 Hz	0.5 Hz	0.5 Hz	0.5 Hz	0.5 Hz	0.5 Hz
• on lamp load, max.	0.5 Hz	10 Hz	10 Hz	1 Hz	1 Hz	1 Hz
Aggregate current of outputs (per group)						
• horizontal installation						
- up to 40 °C, max.	0.5 A; (8 A per module)	6 A	4 A	4 A	8 A	4 A
- up to 50 °C, max.		4 A				
- up to 60 °C, max.	0.5 A; (8 A per module)	3 A	4 A	2 A	4 A	2 A
• vertical installation						
- up to 40 °C, max.	0.5 A; (8 A per module)	4 A	4 A	2 A	4 A	2 A
Cable length						
• Cable length, shielded, max.	1 000 m	1 000 m	1 000 m	1 000 m	1 000 m	1 000 m
• Cable length unshielded, max.	600 m	600 m	600 m	600 m	600 m	600 m

SIMATIC S7-300

Digital modules

SM 322 digital output modules

Technical specifications (continued)

	6ES7 322-5GH00-0AB0	6ES7 322-1CF00-0AA0	6ES7 322-1BF01-0AA0	6ES7 322-1FF01-0AA0	6ES7 322-5FF00-0AB0	6ES7 322-1FH00-0AA0
Interrupts/diagnostics/status information						
Alarms						
• Diagnostic alarm	Yes; Parameterizable	No	No	No	Yes; Parameterizable	No
Diagnostic messages						
• Diagnostics	Yes; Parameters can be assigned	No	No	Yes	Yes	Yes
Galvanic isolation						
Galvanic isolation digital outputs						
• between the channels, in groups of	1	4	4	4	1	8
• between the channels and the backplane bus	Yes; Optocoupler	Yes; Optocoupler	Yes; Optocoupler	Yes; Optocoupler	Yes; Optocoupler	Yes; Optocoupler
Isolation						
Isolation checked with	1500 V AC	1500 V AC	500 V DC	1500 V AC	1500 V AC	4000 VDC
Connection method						
required front connector	40-pin	20-pin	20-pin	20-pin	40-pin	20-pin
Dimensions						
Width	40 mm	40 mm	40 mm	40 mm	40 mm	40 mm
Height	125 mm	125 mm	125 mm	125 mm	125 mm	125 mm
Depth	120 mm	120 mm	120 mm	120 mm	120 mm	120 mm
Weight						
Weight, approx.	260 g	250 g	190 g	275 g	275 g	275 g
	6ES7 322-1FL00-0AA0	6ES7 322-1HF01-0AA0	6ES7 322-1HF10-0AA0	6ES7 322-5HF00-0AB0	6ES7 322-1HH01-0AA0	
Supply voltage						
Load voltage L+						
• Rated value (DC)		24 V	120 V	24 V	120 V	
Load voltage L1						
• Rated value (AC)	120 V; 120/230 V AC		230 V	230 V	230 V	
Input current						
from load voltage L+ (without load), max.		110 mA; Current consumption of relay				
from load voltage L1 (without load), max.	10 mA	110 mA				
from backplane bus 5 V DC, max.	190 mA	40 mA	40 mA	100 mA	100 mA	
Power losses						
Power loss, typ.	25 W	3.2 W	4.2 W	3.5 W	4.5 W	
Digital outputs						
Number/binary outputs	32	8; Relay	8; Relay	8; Relay	16; Relay	
Lamp load, max.	50 W	50 W	1 500 W; 230 V AC	1 500 W; 230 V AC	50 W; 230 V AC	
Output voltage						
• for signal "1", min.	L1 (-0.8 V)					
Output current						
• for signal "1" rated value	1 A	2 A	5 A	5 A	2 A	
• for signal "1" permissible range for 0 to 40 °C, min.	10 mA					
• for signal "1" permissible range for 0 to 40 °C, max.	1 A					
• for signal "1" permissible range for 40 to 60 °C, min.	10 mA					
• for signal "1" permissible range for 40 to 60 °C, max.	1 A					
• for signal "1" minimum load current	10 mA	5 mA	5 mA	10 mA	10 mA	
• for signal "1" permissible surge current, max.	10 A; per group (for 2 AC cycles)					
• for signal "0" residual current, max.	2 mA					

Technical specifications (continued)

	6ES7 322-1FL00-0AA0	6ES7 322-1HF01-0AA0	6ES7 322-1HF10-0AA0	6ES7 322-5HF00-0AB0	6ES7 322-1HH01-0AA0
Switching frequency					
• with resistive load, max.	10 Hz	2 Hz	2 Hz	2 Hz	1 Hz
• with inductive load, max.	0.5 Hz	0.5 Hz	0.5 Hz	0.5 Hz	0.5 Hz
• on lamp load, max.	1 Hz	2 Hz	2 Hz	2 Hz	1 Hz
• mechanical, max.		10 Hz	10 Hz	10 Hz	10 Hz
Aggregate current of outputs (per group)					
• horizontal installation					
- up to 40 °C, max.	4 A				
- up to 60 °C, max.	3 A		5 A	5 A	8 A
• vertical installation					
- up to 40 °C, max.	4 A		5 A	5 A	8 A
Relay outputs					
• Rated input voltage of relay coil L+ (DC)		24 V; 110 mA	24 V		24 V
• Number of operating cycles, max.		300 000; 230 V AC: 100000; 120 V AC: 200000; 24 V DC: 300000 (at 2 A)	300 000; 300000 (24 V DC, at 2 A); 200000 (120 V AC, at 3 A); 100000 (230 V AC, at 3 A)	100 000; 100000 (24 V DC, at 5 A), 100000 (230 V AC, at 5 A)	100 000; 50000 (24 V DC, at 2 A); 700000 (120 V AC, at 2 A); 100000 (230 V AC, at 2 A)
• Switching capacity of contacts					
- with inductive load, max.		2 A; 2 A (230 V AC), 2 A (24 V DC)	3 A; 3 A (230 V DC); 2 A (24 V AC)	5 A; 5 A (230 V DC); 5 A (24 V AC)	2 A; 2 A (230 V AC), 2 A (24 V DC)
- Switching frequency/contacts/at ohmic load/maximum		2 A	8 A; 8 A (230 V DC); 5 A (24 V AC)	5 A; 5 A (230 V DC); 5 A (24 V AC)	2 A; 2 A (230 V AC), 2 A (24 V DC)
Cable length					
• Cable length, shielded, max.	1 000 m	1 000 m	1 000 m	1 000 m	1 000 m
• Cable length unshielded, max.	600 m	600 m	600 m	600 m	600 m
Interrupts/diagnostics/status information					
Alarms					
• Diagnostic alarm	No	No	No	Yes; Parameterizable	No
Diagnostic messages					
• Diagnostics	Yes	No	No	Yes	No
Galvanic isolation					
Galvanic isolation digital outputs					
• between the channels, in groups of	8	2	1	1	8
• between the channels and the back-plane bus	Yes; Optocoupler	Yes; Optocoupler	Yes; Optocoupler	Yes; Optocoupler	Yes; Optocoupler
Isolation					
Isolation checked with	4000 VDC	1500 V AC	2000 V AC	1500 V AC	1500 V AC
Connection method					
required front connector	20-pin	20-pin	40-pin	40-pin	20-pin
Dimensions					
Width	80 mm	40 mm	40 mm	40 mm	40 mm
Height	125 mm	125 mm	125 mm	125 mm	125 mm
Depth	117 mm	120 mm	120 mm	120 mm	120 mm
Weight					
Weight, approx.	500 g	190 g	320 g	320 g	250 g

SIMATIC S7-300

Digital modules

SM 322 digital output modules

Ordering data

SM 322 digital output modules

incl. labeling strips, bus connector

8 outputs, 24 V DC, 2 A

16 outputs, 24 V DC, 0.5 A

16 outputs, 24 V DC, 0.5 A, high speed

32 outputs, 24 V DC, 0.5 A

64 outputs, 24 V DC, 0.3 A

Note:

6ES7392-4...0-0AA0 connection cable and 6ES7392-1.N00-0AA0 terminal blocks necessary.

64 outputs, 24 V DC, 0.3 A, sink output

Note:

6ES7392-4...0-0AA0 connection cable and 6ES7392-1.N00-0AA0 terminal blocks necessary.

8 outputs, 24 V DC, 0.5 A, diagnostics-capable

16 outputs, 24/48 V DC, 0.5 A

8 outputs, 48 to 125 V DC, 1.5 A

8 outputs, 120/230 V AC, 1 A

8 outputs, 120/230 V AC, 2 A

16 outputs, 120/230 V AC, 1 A

32 outputs, 120 V AC, 1 A

8 outputs, relay contacts, 2 A

8 outputs, relay contacts, 5 A

8 outputs, relay contacts, 5 A, with RC filter, overvoltage protection

16 outputs, relay contacts, 8 A

Front connector

20-pin, with screw contacts

- 1 unit
- 100 units

20-pin, with spring-loaded contacts

- 1 unit
- 100 units

40-pin, with screw contacts

- 1 unit
- 100 units

40-pin, with spring-loaded contacts

- 1 unit
- 100 units

S7-300 connecting cable

for 64-channel modules; 2 units

1 m

2.5 m

5 m

Terminal block

for 64-channel modules; 2 units

with screw contacts

with spring-loaded contacts

Order No.

6ES7 322-1BF01-0AA0

6ES7 322-1BH01-0AA0

6ES7 322-1BH10-0AA0

6ES7 322-1BL00-0AA0

6ES7 322-1BP00-0AA0

6ES7 322-1BP50-0AA0

6ES7 322-8BF00-0AB0

6ES7 322-5GH00-0AB0

6ES7 322-1CF00-0AA0

6ES7 322-1FF01-0AA0

6ES7 322-5FF00-0AB0

6ES7 322-1FH00-0AA0

6ES7 322-1FL00-0AA0

6ES7 322-1HF01-0AA0

6ES7 322-1HF10-0AA0

6ES7 322-5HF00-0AB0

6ES7 322-1HH01-0AA0

6ES7 392-1AJ00-0AA0

6ES7 392-1AJ00-1AB0

6ES7 392-1BJ00-0AA0

6ES7 392-1BJ00-1AB0

6ES7 392-1AM00-0AA0

6ES7 392-1AM00-1AB0

6ES7 392-1BM01-0AA0

6ES7 392-1BM01-1AB0

6ES7 392-4BB00-0AA0

6ES7 392-4BC50-0AA0

6ES7 392-4BF00-0AA0

6ES7 392-1AN00-0AA0

6ES7 392-1BN00-0AA0

Order No.

Front door, elevated design

e.g. for 32-channel modules; for connecting 1.3 mm²/16 AWG conductors

SIMATIC TOP connect

See page 5/224; for information about which components can be used for the respective module, see Industry Mall

Bus connectors

1 unit (spare part)

Set of fuses for SM 322

10 fuses 8 A quick-response, 2 fuse holders; for 6ES7 322-1FF01-0AA0, 6ES7 322-1FH00-0AA0

10 fuses 6.3 A; for 6ES7 322-1CF00-0AA0

Labeling strips

10 units (spare part)

for modules with 20-pin front connector

for modules with 40-pin front connector

Label cover

10 units (spare part)

for modules with 20-pin front connector

for modules with 40-pin front connector

Labeling sheets for machine inscription

for modules with 20-pin front connector, DIN A4, for printing with laser printer; 10 units

petrol

light-beige

yellow

red

for modules with 40-pin front connector, DIN A4, for printing with laser printer; 10 units

petrol

light-beige

yellow

red

SIMATIC Manual Collection

Electronic manuals on DVD, multilingual

SIMATIC Manual Collection update service for 1 year

Current "Manual Collection" DVD and the three subsequent updates

S7-300 manual

Design, CPU data, module data, instruction list

German

English

6ES7 328-0AA00-7AA0

6ES7 390-0AA00-0AA0

6ES7 973-1HD00-0AA0

6ES7 973-1GC00-0AA0

6ES7 392-2XX00-0AA0

6ES7 392-2XX10-0AA0

6ES7 392-2XY00-0AA0

6ES7 392-2XY10-0AA0

6ES7 392-2AX00-0AA0

6ES7 392-2BX00-0AA0

6ES7 392-2CX00-0AA0

6ES7 392-2DX00-0AA0

6ES7 392-2AX10-0AA0

6ES7 392-2BX10-0AA0

6ES7 392-2CX10-0AA0

6ES7 392-2DX10-0AA0

6ES7 998-8XC01-8YE0

6ES7 998-8XC01-8YE2

6ES7 398-8FA10-8AA0

6ES7 398-8FA10-8BA0

Overview



- Digital inputs and outputs
- For connecting standard switches, two-wire proximity switches, solenoid valves, contactors, low-power motors, lamps and motor starters

Technical specifications

	6ES7 323-1BH01-0AA0	6ES7 323-1BL00-0AA0	6ES7 327-1BH00-0AB0
Supply voltage			
Load voltage L+			
• Rated value (DC)	24 V	24 V	24 V
Input current			
from load voltage L+ (without load), max.	40 mA	80 mA	20 mA
from backplane bus 5 V DC, max.	40 mA	80 mA	60 mA
Power losses			
Power loss, typ.	3.5 W	6.5 W	3 W
Digital inputs			
Number/binary inputs	8	16	8; 8 hard-wired, 8 others individually parameterizable
Input characteristic curve acc. to IEC 61131, Type 1	Yes	Yes	Yes
Number of simultaneously controllable inputs			
• all mounting positions			
- up to 40 °C, max.	8	16	16
- up to 60 °C, max.	8	8	16
Input voltage			
• Type of input voltage	DC	DC	DC
• Rated value, DC	24 V	24 V	24 V
• for signal "0"	-30 to +5 V	-30 to +5 V	-30 to +5 V
• for signal "1"	13 to 30 V	13 to 30 V	15 to 30 V
Input current			
• for signal "1", typ.	7 mA	7 mA	6 mA
Input delay (for rated value of input voltage)			
• for standard inputs			
- at "0" to "1", min.	1.2 ms	1.2 ms	1.2 ms
- at "0" to "1", max.	4.8 ms	4.8 ms	4.8 ms
- at "1" to "0", min.	1.2 ms	1.2 ms	1.2 ms
- at "1" to "0", max.	4.8 ms	4.8 ms	4.8 ms
Cable length			
• Cable length, shielded, max.	1 000 m	1 000 m	1 000 m
• Cable length unshielded, max.	600 m	600 m	600 m

SIMATIC S7-300

Digital modules

SM 323/SM 327 digital input/output modules

Technical specifications (continued)

	6ES7 323-1BH01-0AA0	6ES7 323-1BL00-0AA0	6ES7 327-1BH00-0AB0
Digital outputs			
Number/binary outputs	8	16	8; can also be parameterized individually as DI
Functionality/short-circuit strength • Response threshold, typ.	Yes; Electronic 1 A	Yes; Electronic 1 A	Yes; Electronic 1 A
Limitation of inductive shutdown voltage to	L+ (-53 V)	L+ (-48 V)	L+ (-54 V)
Lamp load, max.	5 W	5 W	5 W
Controlling a digital input	Yes	Yes	Yes
Load resistance range • lower limit • upper limit	48 Ω 4 kΩ	48 Ω 4 kΩ	48 Ω 4 kΩ
Output voltage • for signal "1", min.	L+ (-0.8 V)	L+ (-0.8 V)	L+ (-1.5 V)
Output current • for signal "1" rated value • for signal "1" permissible range for 0 to 60 °C, min. • for signal "1" permissible range for 0 to 60 °C, max. • for signal "1" minimum load current • for signal "0" residual current, max.	0.5 A 5 mA 0.6 A 5 mA 0.5 mA	0.5 A 5 mA 0.6 A 5 mA 0.5 mA	0.5 A 5 mA 0.6 A 5 mA 0.5 mA
Output delay with resistive load • "0" to "1", max. • "1" to "0", max.	100 μs 500 μs	100 μs 500 μs	350 μs 500 μs
Parallel switching of 2 outputs • for increased power • for redundant control of a load	No Yes; only outputs of the same group	No Yes; only outputs of the same group	No Yes; only outputs of the same group
Switching frequency • with resistive load, max. • with inductive load, max. • on lamp load, max.	100 Hz 0.5 Hz 10 Hz	100 Hz 0.5 Hz 100 Hz	100 Hz 0.5 Hz 10 Hz
Aggregate current of outputs (per group) • horizontal installation - up to 40 °C, max. - up to 60 °C, max. • vertical installation - up to 40 °C, max.	4 A 4 A 4 A	4 A 3 A 2 A	4 A 3 A 2 A
Cable length • Cable length, shielded, max. • Cable length unshielded, max.	1 000 m 600 m	1 000 m 600 m	1 000 m 600 m
Encoder			
Connectable encoders • 2-wire sensor - Permissible quiescent current (2-wire sensor), max.	Yes 2 mA	Yes 1.5 mA	Yes 1.5 mA
Isochronous mode			
Isochronous operation (application synchronized up to terminal)	No	No	No
Interrupts/diagnostics/status information			
Alarms • Alarms	No	No	No
Diagnostic messages • Diagnostic functions	No	No	No
Diagnostics indication LED • Status indicator digital output (green) • Status indicator digital input (green)	Yes Yes	Yes Yes	Yes Yes

Technical specifications (continued)

	6ES7 323-1BH01-0AA0	6ES7 323-1BL00-0AA0	6ES7 327-1BH00-0AB0
Galvanic isolation			
Galvanic isolation digital inputs			
• between the channels	Yes	Yes	No
• between the channels, in groups of	8	16	
• between the channels and the backplane bus	Yes; Optocoupler	Yes; Optocoupler	Yes; Optocoupler
Galvanic isolation digital outputs			
Galvanic isolation digital outputs			
• between the channels	Yes	Yes	No
• between the channels, in groups of	8	8	
• between the channels and the backplane bus	Yes; Optocoupler	Yes; Optocoupler	Yes; Optocoupler
Permissible potential difference			
between different circuits	75 VDC / 60 VAC	75 VDC / 60 VAC	75 VDC / 60 VAC
Isolation			
Isolation checked with	500 V DC	500 V DC	500 V DC
Connection method			
required front connector	20-pin	40-pin	20-pin
Dimensions			
Width	40 mm	40 mm	40 mm
Height	125 mm	125 mm	125 mm
Depth	120 mm	120 mm	120 mm
Weight			
Weight, approx.	220 g	260 g	200 g

SIMATIC S7-300

Digital modules

SM 323/SM 327 digital input/output modules

Ordering data	Order No.		Order No.
SM 323 digital input/output modules incl. labeling strips, bus connector 8 inputs, 8 outputs 16 inputs, 16 outputs	6ES7 323-1BH01-0AA0 6ES7 323-1BL00-0AA0	Labeling sheets for machine inscription for modules with 20-pin front connector, DIN A4, for printing with laser printer; 10 units petrol light-beige yellow red for modules with 40-pin front connector, DIN A4, for printing with laser printer; 10 units petrol light-beige yellow red	6ES7 392-2AX00-0AA0 6ES7 392-2BX00-0AA0 6ES7 392-2CX00-0AA0 6ES7 392-2DX00-0AA0 6ES7 392-2AX10-0AA0 6ES7 392-2BX10-0AA0 6ES7 392-2CX10-0AA0 6ES7 392-2DX10-0AA0
SM 327 digital input/output modules incl. labeling strips, bus connector 8 inputs, 8 inputs or outputs (can be configured)	6ES7 327-1BH00-0AB0	SIMATIC Manual Collection Electronic manuals on DVD, multilingual: LOGO!, SIMADYN, SIMATIC bus components, SIMATIC C7, SIMATIC distributed I/O, SIMATIC HMI, SIMATIC Sensors, SIMATIC NET, SIMATIC PC Based Automation, SIMATIC PCS 7, SIMATIC PG/PC, SIMATIC S7, SIMATIC Software, SIMATIC TDC	6ES7 998-8XC01-8YE0
Front connector 20-pin, with screw contacts <ul style="list-style-type: none"> • 1 unit • 100 units 20-pin, with spring-loaded contacts <ul style="list-style-type: none"> • 1 unit • 100 units 40-pin, with screw contacts <ul style="list-style-type: none"> • 1 unit • 100 units 40-pin, with spring-loaded contacts <ul style="list-style-type: none"> • 1 unit • 100 units 	6ES7 392-1AJ00-0AA0 6ES7 392-1AJ00-1AB0 6ES7 392-1BJ00-0AA0 6ES7 392-1BJ00-1AB0 6ES7 392-1AM00-0AA0 6ES7 392-1AM00-1AB0 6ES7 392-1BM01-0AA0 6ES7 392-1BM01-1AB0	SIMATIC Manual Collection update service for 1 year Current "Manual Collection" DVD and the three subsequent updates	6ES7 998-8XC01-8YE2
Front door, elevated design e.g. for 32 channel modules; enables connection of 1.3 mm ² /16 AWG wires	6ES7 328-0AA00-7AA0	S7-300 manual Design, CPU data, module data, instruction list German English	6ES7 398-8FA10-8AA0 6ES7 398-8FA10-8BA0
SIMATIC TOP connect See page 5/224; for information about which components can be used for the respective module, see Industry Mall			
Bus connectors 1 unit (spare part)	6ES7 390-0AA00-0AA0		
Labeling strips 10 units (spare part) for modules with 20-pin front connector for modules with 40-pin front connector	6ES7 392-2XX00-0AA0 6ES7 392-2XX10-0AA0		
Label cover 10 units (spare part) for modules with 20-pin front connector for modules with 40-pin front connector	6ES7 392-2XY00-0AA0 6ES7 392-2XY10-0AA0		

Overview



- Digital inputs
- For connection of switches and 2-wire proximity switches (BEROs)

Note:

SIPLUS extreme products are based on Siemens Industry standard products. The contents listed here were taken from the respective standard products. SIPLUS extreme-specific information was added.

SIPLUS SM 321	16 DI 24 V DC 1 X 20-pin	32 DI 24 V DC 1 X 40-pin	16 DI 48-125 V DC 1 X 20-pin
Order number	6AG1 321-1BH02-2AA0	6AG1 321-1BL00-2AA0	6AG1 321-1CH20-2AA0
Order No. based on	6ES7 321-1BH02-0AA0	6ES7 321-1BL00-0AA0	6ES7 321-1CH20-0AA0
Ambient temperature range	-40 ... +70 °C	-40 ... +70 °C	-25 ... +70 °C
Compliant with the standards for electronic equipment used on rolling stock (EN 50155, temperature T1, category 1).	Yes	Yes	Yes
Conformal coating	Coating of the printed circuit boards and the electronic components		
Technical data	The technical data of the standard product applies except for the ambient conditions.		
SIPLUS SM 321	8 DI 120/230 V AC 1 X 20-pin	8 DI 120/230 V AC 1 X 40-pin	16 DI 120/230 V AC 1 X 20-pin
Order number	6AG1 321-1FF01-2AA0	6AG1 321-1FF10-7AA0	6AG1 321-1FH00-7AA0
Order No. based on	6ES7 321-1FF01-0AA0	6ES7 321-1FF10-0AA0	6ES7 321-1FH00-0AA0
Ambient temperature range	-40 ... +70 °C	-25 ... +70 °C	-40 ... +70 °C
Compliant with the standards for electronic equipment used on rolling stock (EN 50155, temperature T1, category 1).	Yes	No	No
Conformal coating	Coating of the printed circuit boards and the electronic components		
Technical data	The technical data of the standard product applies except for the ambient conditions.		
SIPLUS SM 321	16 DI 24 V DC 1 X 20-pin	16 DI 24 V DC, 1 X 20-pin (0-1 threshold)	16 DI 24 V DC DIAGNOSTICS
Order number	6AG1 321-7BH01-2AB0	6AG1 321-7BH01-4AS0	6AG1 321-7TH00-4AB0
Order No. based on	6ES7 321-7BH01-0AB0	6ES7 321-7BH01-0AB0	6ES7 321-7TH00-0AB0
Ambient temperature range	- 25 ... +70 °C	0 ... +60 °C	0 ... +60 °C
Compliant with the standards for electronic equipment used on rolling stock (EN 50155, temperature T1, category 1).	Yes	No	No
Conformal coating	Coating of the printed circuit boards and the electronic components		
Technical data	The technical data of the standard product applies except for the ambient conditions.		

SIMATIC S7-300

SIPLUS digital modules

SIPLUS SM 321 digital input modules

Overview (continued)

Ambient conditions

Relative humidity	100%, condensation/frost permissible. No commissioning if condensation present.
Biologically active substances, compliance with EN 60721-3-3	Class 3B2 mold and fungal spores (excluding fauna). The supplied plug covers must remain in place over the unused interfaces during operation!
Chemically active substances, compliance with EN 60721-3-3	Class 3C4 incl. salt spray in accordance with EN 60068-2-52 (degree of severity 3). The supplied plug covers must remain in place over the unused interfaces during operation!
Mechanically active substances, compliance with EN 60721-3-3	Class 3S4 incl. sand, dust. The supplied plug covers must remain in place over the unused interfaces during operation!
Air pressure (depending on the highest positive temperature range specified)	1080 ... 795 hPa (-1000 ... +2000 m) see ambient temperature range 795 ... 658 hPa (+2000 ... +3500 m) derating 10 K 658 ... 540 hPa (+3500 ... +5000 m) derating 20 K

The technical documentation on SIPLUS can be found here:
www.siemens.com/siplus-extreme

Ordering data

SIPLUS SM 321 digital input modules

(extended temperature range and medial exposure)

incl. labeling strips, bus connector

16 inputs, 24 V DC

32 inputs, 24 V DC

16 inputs, 48 to 120 V DC

8 inputs, 120/230 V AC

8 inputs, 120/230 V AC, single root

16 inputs, 120/230 V AC

16 inputs, 24 V DC, diagnostics-capable

16 inputs, 24 V DC (0-1 threshold)

16 inputs, NAMUR, redundant design possible

Accessories

Order No.

6AG1 321-1BH02-2AA0

6AG1 321-1BL00-2AA0

6AG1 321-1CH20-2AA0

6AG1 321-1FF01-2AA0

6AG1 321-1FF10-7AA0

6AG1 321-1FH00-7AA0

6AG1 321-7BH01-2AB0

6AG1 321-7BH01-4AS0

6AG1 321-7TH00-4AB0

See SIMATIC S7-300 digital input modules, page 5/54

Overview



- Digital outputs
- For connecting solenoid valves, contactors, small-power motors, lamps and motor starters

Note:

SIPLUS extreme products are based on Siemens Industry standard products. The contents listed here were taken from the respective standard products. SIPLUS extreme-specific information was added.

SIPLUS SM 322	8 DO 24 V DC, 2 A, 1 X 20-pin	16 DO 24 V DC, 0.5 A, 1 X 20-pin	32 DO 24 V DC, 0.5 A, 1 X 40-pin
Order number	6AG1 322-1BF01-2XB0	6AG1 322-1BH01-2AA0	6AG1 322-1BL00-2AA0
Order No. based on	6ES7 322-1BF01-0AA0	6ES7 322-1BH01-0AA0	6ES7 322-1BL00-0AA0
Ambient temperature range	-25 ... +70 °C	-25 ... +70 °C	-25 ... +70 °C
Compliant with the standards for electronic equipment used on rolling stock (EN 50155, temperature T1, category 1).	No	Yes	Yes
Conformal coating	Coating of the printed circuit boards and the electronic components		
Technical data	The technical data of the standard product applies except for the ambient conditions.		
SIPLUS SM 322	8 DO 48 - 125 V DC 1.5 A, 1 X 20 pin	8 DO 120/230 V AC 1 A, 1 X 20 pin	16 DO, 120/230 V AC 1 A, 1 X 20-pin
Order number	6AG1 322-1CF00-7AA0	6AG1 322-1FF01-7AA0	6AG1 322-1FH00-7AA0
Order No. based on	6ES7 322-1CF00-0AA0	6ES7 322-1FF01-0AA0	6ES7 322-1FH00-0AA0
Ambient temperature range	-25 ... +70 °C	-40 ... +70 °C	-40 ... +70 °C
Compliant with the standards for electronic equipment used on rolling stock (EN 50155, temperature T1, category 1).	No	No	No
Conformal coating	Coating of the printed circuit boards and the electronic components		
Technical data	The technical data of the standard product applies except for the ambient conditions.		
SIPLUS SM 322	8 DO (relay) 24 V DC, 5 A/230 V AC 5 A, 1 X 40-pin	16 RO relay contacts, 1 X 20-pin	8 DO 120/230 V AC 2 A, 1 X 40 pin
Order number	6AG1 322-1HF10-2AA0	6AG1 322-1HH01-2AA0	6AG1 322-5FF 00-4AB0
Order No. based on	6ES7 322-1HF10-0AA0	6ES7 322-1HH01-0AA0	6ES7 322-5FF00-0AB0
Ambient temperature range	-25 ... +60 °C	-40 ... +70 °C	0 ... +60 °C
Compliant with the standards for electronic equipment used on rolling stock (EN 50155, temperature T1, category 1).	Yes	Yes	No
Conformal coating	Coating of the printed circuit boards and the electronic components		
Technical data	The technical data of the standard product applies except for the ambient conditions.		

SIMATIC S7-300

SIPLUS digital modules

SIPLUS SM 322 digital output modules

Overview (continued)

SIPLUS SM 322	8 RO (relay), 24 V DC, 120 - 230 V AC, 5 A, 1 X 40 pin	8 DO 24 V DC, 0.5 A, short-circuit protection, diagnostics, 1 X 20-pin	16 DO 24 V DC, 0.5 A, diagnostics, wire-break detection 0/1 signal, 1 X 40-pin
Order number	6AG1 322-5HF00-4AB0	6AG1 322-8BF00-2AB0	6AG1 322-8BH01-2AB0
Order No. based on	6ES7 322-5HF00-0AB0	6ES7 322-8BF00-0AB0	6ES7 322-8BH01-0AB0
Ambient temperature range	0 ... +60 °C	-25 ... +70 °C	-25 ... +70 °C
Compliant with the standards for electronic equipment used on rolling stock (EN 50155, temperature T1, category 1).	No	Yes	No
Conformal coating	Coating of the printed circuit boards and the electronic components		
Technical data	The technical data of the standard product applies except for the ambient conditions.		

5

Ambient conditions

Relative humidity	100%, condensation/frost permissible. No commissioning if condensation present.
Biologically active substances, compliance with EN 60721-3-3	Class 3B2 mold and fungal spores (excluding fauna). The supplied plug covers must remain in place over the unused interfaces during operation!
Chemically active substances, compliance with EN 60721-3-3	Class 3C4 incl. salt spray in accordance with EN 60068-2-52 (degree of severity 3). The supplied plug covers must remain in place over the unused interfaces during operation!
Mechanically active substances, compliance with EN 60721-3-3	Class 3S4 incl. sand, dust. The supplied plug covers must remain in place over the unused interfaces during operation!
Air pressure (depending on the highest positive temperature range specified)	1080 ... 795 hPa (-1000 ... +2000 m) see ambient temperature range 795 ... 658 hPa (+2000 ... +3500 m) derating 10 K 658 ... 540 hPa (+3500 ... +5000 m) derating 20 K

Ordering data

SIPLUS SM 322 digital output modules

(extended temperature range and medial exposure)

incl. labeling strips, bus connector

8 outputs, 24 V DC, 2 A

6AG1 322-1BF01-2XB0

8 outputs, 24 V DC, 0.5 A, diagnostics-capable

6AG1 322-8BF00-2AB0

16 outputs, 24 V DC, 0.5 A

6AG1 322-1BH01-2AA0

32 outputs, 24 V DC, 0.5 A

6AG1 322-1BL00-2AA0

8 outputs, 48 to 125 V DC, 1.5 A

6AG1 322-1CF00-7AA0

8 outputs, relay contacts, 5 A

6AG1 322-1HF10-2AA0

8 outputs, relay contacts, 5 A, with RC filter, overvoltage protection

6AG1 322-5HF00-4AB0

8 outputs, 120/230 V AC, 1 A

6AG1 322-1FF01-7AA0

8 outputs, 120/230 V AC, 2 A

6AG1 322-5FF00-4AB0

16 outputs, 120/230 V AC, 1 A

6AG1 322-1FH00-7AA0

16 outputs, relay contacts, 8 A

6AG1 322-1HH01-2AA0

16 outputs, 24 V DC / 0.5 A, redundant design possible

6AG1 322-8BH01-2AB0

Accessories

See SIMATIC S7-300 digital output modules, page 5/60

The technical documentation on SIPLUS can be found here:
www.siemens.com/siplus-extreme

SIMATIC S7-300

SIPLUS digital modules

SIPLUS SM 323 digital input/output modules

Overview



- Digital inputs and outputs
- For connection of switches, 2-wire proximity switches (BERO), solenoid valves, contactors, low-power motors, lamps and motor starters

Note:

SIPLUS extreme products are based on Siemens Industry standard products. The contents listed here were taken from the respective standard products. SIPLUS extreme specific information was added.

SIPLUS SM 322	8 DI/8 DO 24 V DC, 0.5 A Total current 2 A, 1 X 20-pin
Order No.	6AG1 323-1BH01-2AA0
Order number based on	6ES7 323-1BH01-0AA0
Ambient temperature range	-40 ... +70 °C
Compliant with the standards for electronic equipment used on rolling stock (EN 50155, temperature T1, category 1).	Yes
Conformal coating	Coating of the printed circuit boards and the electronic components
Technical data	The technical data of the standard product applies except for the ambient conditions.
Ambient conditions	
Relative humidity	100%, condensation/frost permissible. No commissioning if condensation present.
Biologically active substances, compliance with EN 60721-3-3	Class 3B2 mold and fungal spores (excluding fauna). The supplied plug covers must remain in place over the unused interfaces during operation!
Chemically active substances, compliance with EN 60721-3-3	Class 3C4 incl. salt spray in accordance with EN 60068-2-52 (degree of severity 3). The supplied plug covers must remain in place over the unused interfaces during operation!
Mechanically active substances, compliance with EN 60721-3-3	Class 3S4 incl. sand, dust. The supplied plug covers must remain in place over the unused interfaces during operation!
Air pressure (depending on the highest positive temperature range specified)	1 080 ... 795 hPa (-1 000 ... +2 000 m) see ambient temperature range 795 ... 658 hPa (+2 000 ... +3 500 m) derating 10 K 658 ... 540 hPa (+3 500 ... +5 000 m) derating 20 K

For technical documentation on SIPLUS, see:
www.siemens.com/siplus-extreme

Ordering data	Order No.
SIPLUS SM 323 digital input/output module (extended temperature range and medial exposure) incl. labeling strips, bus connector 8 inputs, 8 outputs	6AG1 323-1BH01-2AA0
Accessories	See SIMATIC S7-300 digital input/output modules, page 5/64

SIMATIC S7-300

Analog modules

SM 331 analog input modules

Overview



- Analog inputs
- For connection of voltage and current sensors, thermocouples, resistors and resistance thermometers

5

Technical specifications

	6ES7 331-7KF02-0AB0	6ES7 331-7HF01-0AB0	6ES7 331-1KF02-0AB0	6ES7 331-7KB02-0AB0
Supply voltage				
Load voltage L+				
• Rated value (DC)	24 V	24 V		24 V
• Reverse polarity protection	Yes	Yes		Yes
Input current				
from load voltage L+ (without load), max.	200 mA	50 mA		80 mA
from backplane bus 5 V DC, max.	50 mA	60 mA	90 mA	50 mA
Power losses				
Power loss, typ.	1 W	1.5 W	0.4 W	1.3 W
Analog inputs				
Number of analog inputs	8	8	8	2
Number of analog inputs for resistance measurement	4		8	1
permissible input voltage for voltage input (destruction limit), max.	20 V; continuous; 75 V for max. 1 s (mark to space ratio 1:20)	20 V; 20 V DC permanent, 75 V DC for max. 1 s (duty factor 1:20)	30 V; 12 V continuous, 30 V for max. 1 s	20 V; continuous; 75 V for max. 1 s (mark to space ratio 1:20)
permissible input current for current input (destruction limit), max.	40 mA	40 mA	40 mA	40 mA
Input ranges (rated values), voltages				
• 0 to +10 V	No	No	Yes	No
• 1 to 5 V	Yes	Yes	Yes	Yes
• 1 to 10 V	No		No	No
• -1 V to +1 V	Yes	Yes	Yes	Yes
• -10 V to +10 V	Yes	Yes	Yes	Yes
• -2.5 V to +2.5 V	Yes		No	Yes
• -250 mV to +250 mV	Yes		No	Yes
• -5 V to +5 V	Yes	Yes	Yes	Yes
• -50 mV to +50 mV	No		Yes	No
• -500 mV to +500 mV	Yes	Yes	Yes	Yes
• -80 mV to +80 mV	Yes	Yes	No	Yes
Input ranges (rated values), currents				
• 0 to 20 mA	Yes	Yes	Yes	Yes
• -10 to +10 mA	Yes		No	Yes
• -20 to +20 mA	Yes	Yes	Yes	Yes
• -3.2 to +3.2 mA	Yes		No	Yes
• 4 to 20 mA	Yes	Yes	Yes	Yes

Technical specifications (continued)

	6ES7 331-7KF02-0AB0	6ES7 331-7HF01-0AB0	6ES7 331-1KF02-0AB0	6ES7 331-7KB02-0AB0
Input ranges (rated values), thermoelements				
• Type B	No		No	No
• Type E	Yes		No	Yes
• Type J	Yes		No	Yes
• Type K	Yes		No	Yes
• Type L	Yes		No	No
• Type N	Yes		No	Yes
• Type R	No		No	No
• Type S	No		No	No
• Type T	No		No	No
• Type U	No		No	No
• Type TXK/TXK(L) to GOST	No		No	No
Input ranges (rated values), resistance thermometers				
• Cu 10	No		No	No
• Ni 100	Yes; Standard		Yes; Standard/climate	Yes
• Ni 1000	No		Yes	No
• LG-Ni 1000	No		Yes; Standard/climate	No
• Ni 120	No		No	No
• Ni 200	No		No	No
• Ni 500	No		No	No
• Pt 100	Yes; Standard		Yes; Standard/climate	Yes
• Pt 1000	No		No	No
• Pt 200	No		No	No
• Pt 500	No		No	No
Input ranges (rated values), resistors				
• 0 to 150 ohms	Yes		No	Yes
• 0 to 300 ohms	Yes		No	Yes
• 0 to 600 ohms	Yes		Yes	Yes
• 0 to 6000 ohms	No		Yes	No
Thermocouple (TC)				
• for thermocouples	Type E, J, K, L, N		No	Type E, J, K, L, N
• Temperature compensation				
- Parameterizable	Yes		No	Yes
- internal temperature compensation	Yes		No	Yes
- external temperature compensation with compensations socket	Yes		No	Yes
Resistance thermometer (RTD)				
• Characteristic linearization				
- for resistance thermometer	Pt100 (standard, climatic range), Ni100 (standard, climatic range)		yes; Pt100 standard/air con.; Ni100 standard/air con.; Ni1000 standard/air con.; LG-Ni1000 standard/air con.	Pt100 (standard, climatic range), Ni100 (standard, climatic range)
Characteristic linearization				
• Parameterizable	Yes		Yes	Yes
Cable length				
• Cable length, shielded, max.	200 m; 50 m at 80 mV and thermocouples	200 m	200 m; max. 50 m at 50 mV	200 m; 50 m at 80 mV and thermocouples
Analog value creation				
Measurement principle	integrating	Actual value encryption	integrating	integrating
Integrations and conversion time/ resolution per channel				
• Resolution with overrange (bit including sign), max.	15 bit; Unipolar: 9/12/12/14 bits; bipolar: 9 bits + sign / 12 bits + sign / 12 bits + sign/14 bits + sign	14 bit; Unipolar: 14 bits; bipolar: 13 bits + sign	13 bit	15 bit; Unipolar: 9/12/12/14 bits; bipolar: 9 bits + sign / 12 bits + sign / 12 bits + sign / 14 bits + sign
• Integration time, parameterizable	Yes; 2.5/ 16.67/ 20/ 100 ms	Yes	Yes; 60 / 50 ms	Yes; 2.5/ 16.67/ 20/ 100 ms
• Basic conversion time, ms	3 / 17 / 22 /102 ms	52 µs per channel	66 / 55 ms	3 / 17 / 22 /102 ms
• Interference voltage suppression for interference frequency f1 in Hz	400 / 60 / 50 / 10 Hz	400 / 60 / 50 / 10 Hz	50 / 60 Hz	400 / 60 / 50 / 10 Hz

SIMATIC S7-300

Analog modules

SM 331 analog input modules

Technical specifications (continued)

	6ES7 331-7KF02-0AB0	6ES7 331-7HF01-0AB0	6ES7 331-1KF02-0AB0	6ES7 331-7KB02-0AB0
Encoder				
Connection of signal encoders				
• for current measurement as 2-wire transducer	Yes	Yes	Yes; with external supply	Yes
• for current measurement as 4-wire transducer	Yes	Yes	Yes	Yes
• for resistance measurement with 2-conductor connection	Yes		Yes	Yes
• for resistance measurement with 3-conductor connection	Yes		Yes	Yes
• for resistance measurement with 4-conductor connection	Yes		Yes	Yes
Errors/accuracies				
Operational limit in overall temperature range				
• Voltage, relative to input area	+/- 1 %; +/-1% (80 mV); +/-0.6% (250 to 1000 mV); +/-0.8% (2.5 to 10 V)	+/- 0,4 %	+/- 0,6 %; +/-0.6% (+/-5 V, 10 V, 1 to 5 V, 0 to 10 V); +/-0.5% (+/-50 mV, 500 mV, 1 V)	+/- 1 %; +/-1% (80 mV); +/-0.6% (250 to 1000 mV); +/-0.8% (2.5 to 10 V)
• Current, relative to input area	+/- 0,7 %; From 3.2 to 20 mA	+/- 0,3 %	+/- 0,5 %; +/-20 mA, 0 to 20 mA, 4 to 20 mA	+/- 0,7 %; From 3.2 to 20 mA
• Impedance, relative to input area	+/- 0,7 %; 150, 300, 600 Ohm		+/- 0,5 %; 0 to 6 kohms, 0 to 600 kohms	+/- 0,7 %; 150, 300, 600 Ohm
• Resistance-type thermometer, relative to input area	+/- 0,7 %; +/-0.7% (Pt100/ Ni100); +/-0.8% (Pt100 climate)		1 Kelvin (Pt100, Ni100, climatic; Ni1000, LG-Ni1000, standard; Ni1000, LG-Ni1000, climatic); 1.2 Kelvin (Pt100, Ni100, standard)	+/- 0,7 %; +/-0.7% (Pt100/ Ni100); +/-0.8% (Pt100 climate)
Basic error limit (operational limit at 25 °C)				
• Voltage, relative to input area	+/- 0,6 %; +/-0.4% (250 to 1000 mV); +/-0.6 % (2.5 to 10 mV); +/-0.7 % (80 mV)	+/- 0,25 %	+/- 0,4 %; 0.4% (+/-5 V, 10 V, 1 to 5 V, 0 to 10 V); 0.3% (+/-50 mV, 500 mV, 1 V)	+/- 0,6 %; +/-0.6% (80 mV, 2.5 to 10 V); +/-0.4% (250 to 1000 mV)
• Current, relative to input area	+/- 0,5 %; 3.2 to 20 mA	+/- 0,2 %	+/- 0,3 %; +/-20 mA, 0 to 20 mA, 4 to 20 mA	+/- 0,5 %; 3.2 to 20 mA
• Impedance, relative to input area	+/- 0,5 %; 150, 300, 600 Ohm		+/- 0,3 %; 0 to 6 kohms, 0 to 600 kohms	+/- 0,5 %; 150, 300, 600 Ohm
• Resistance-type thermometer, relative to input area	+/- 0,6 %; +/-0.5% (Pt100/ Ni100); +/-0.6% (Pt100 climate)		1 Kelvin (Pt100, Ni100, standard); 0.8 Kelvin (Pt100, Ni100, climatic; Ni1000, LG-Ni1000, standard; Ni1000, LG-Ni1000, climatic)	+/- 0,6 %; +/-0.5% (Pt100/ Ni100); +/-0.6% (Pt100 climate)
Isochronous mode				
Isochronous operation (application synchronized up to terminal)	No	Yes	No	No
Interrupts/diagnostics/status information				
Alarms				
• Diagnostic alarm	Yes; Parameterizable, channels 0 and 2	Yes; Parameterizable	No	Yes
• Limit value alarm	Yes; Parameterizable	Yes; Parameterizable, channels 0 and 2	No	Yes; Parameterizable, channel 0
Diagnostic messages				
• Diagnostic information readable	Yes	Yes	No	Yes
Galvanic isolation				
Galvanic isolation analog inputs				
• between the channels	No	No	No	No
• between the channels and the backplane bus	Yes	Yes	Yes	Yes
Isolation				
Isolation checked with	500 V DC	500 V DC	500 V DC	500 V DC
Connection method				
required front connector	20-pin	20-pin	40-pin	20-pin
Dimensions				
Width	40 mm	40 mm	40 mm	40 mm
Height	125 mm	125 mm	125 mm	125 mm
Depth	120 mm	120 mm	117 mm	120 mm
Weight				
Weight, approx.	250 g	200 g	250 g	250 g

Technical specifications (continued)

	6ES7 331-7PF01-0AB0	6ES7 331-7PF11-0AB0	6ES7 331-7PE10-0AB0	6ES7 331-7NF00-0AB0	6ES7 331-7NF10-0AB0
Supply voltage					
Load voltage L+					
• Rated value (DC)	24 V	24 V	24 V		24 V
• Reverse polarity protection	Yes	Yes	Yes		Yes
Input current					
from load voltage L+ (without load), max.	240 mA	200 mA	150 mA		200 mA
from backplane bus 5 V DC, max.	100 mA	100 mA	100 mA	130 mA	100 mA
Power losses					
Power loss, typ.	4.6 W	3 W	2.2 W	0.6 W	3 W
Analog inputs					
Number of analog inputs	8	8	6	8	8
Number of analog inputs for resistance measurement	8				
permissible input voltage for voltage input (destruction limit), max.	75 V; 35 V continuous, 75 V for max. 1 s (mark to space ratio 1:20)	75 V; 20 V DC permanent, 75 V DC for max. 1 s (duty factor 1:20)	35 V; 35 V continuous, 75 V for max. 1 s (mark to space ratio 1:20)	50 V; Permanent	75 V; 35 V continuous, 75 V for max. 1 s (mark to space ratio 1:20)
permissible input current for current input (destruction limit), max.				32 mA	40 mA
Input ranges (rated values), voltages					
• 0 to +10 V	No	No	No	No	No
• 1 to 5 V	No	No	No	Yes	Yes
• 1 to 10 V	No	No	No	No	No
• -1 V to +1 V	No	No	Yes	No	No
• -10 V to +10 V	No	No	No	Yes	Yes
• -2.5 V to +2.5 V	No	No	No	No	No
• -250 mV to +250 mV	No	No	Yes	No	No
• -5 V to +5 V	No	No	No	Yes	Yes
• -50 mV to +50 mV	No	No	Yes	No	No
• -500 mV to +500 mV	No	No	Yes	No	No
• -80 mV to +80 mV	No	No	Yes	No	No
Input ranges (rated values), currents					
• 0 to 20 mA	No	No	No	Yes	Yes
• -10 to +10 mA	No	No	No	No	No
• -20 to +20 mA	No	No	No	Yes	Yes
• -3.2 to +3.2 mA	No	No	No	No	No
• 4 to 20 mA	No	No	No	Yes	Yes
Input ranges (rated values), thermoelements					
• Type B	No	Yes	Yes	No	No
• Type E	No	Yes	Yes	No	No
• Type J	No	Yes	Yes	No	No
• Type K	No	Yes	Yes	No	No
• Type L	No	Yes	Yes	No	No
• Type N	No	Yes	Yes	No	No
• Type R	No	Yes	Yes	No	No
• Type S	No	Yes	Yes	No	No
• Type T	No	Yes	Yes	No	No
• Type U	No	Yes	Yes	No	No
• Type TXK/TXK(L) to GOST	No	Yes	Yes	No	No
• Input resistance (Type TXK/TXK(L) to GOST)			10 MΩ		

SIMATIC S7-300

Analog modules

SM 331 analog input modules

Technical specifications (continued)

	6ES7 331-7PF01-0AB0	6ES7 331-7PF11-0AB0	6ES7 331-7PE10-0AB0	6ES7 331-7NF00-0AB0	6ES7 331-7NF10-0AB0
Input ranges (rated values), resistance thermometers					
• Cu 10	Yes	No	No	No	No
• Ni 100	Yes	No	No	No	No
• Ni 1000	Yes	No	No	No	No
• LG-Ni 1000	Yes	No	No	No	No
• Ni 120	Yes	No	No	No	No
• Ni 200	Yes	No	No	No	No
• Ni 500	Yes	No	No	No	No
• Pt 100	Yes	No	No	No	No
• Pt 1000	Yes	No	No	No	No
• Pt 200	Yes	No	No	No	No
• Pt 500	Yes	No	No	No	No
Input ranges (rated values), resistors					
• 0 to 150 ohms	Yes	No	No	No	No
• 0 to 300 ohms	Yes	No	No	No	No
• 0 to 600 ohms	Yes	No	No	No	No
• 0 to 6000 ohms		No	No	No	No
Thermocouple (TC)					
• for thermocouples		Type B, E, J, K, L, N, R, S, T, U, C	Type B, E, J, K, L, N, R, S, T, U, C, TXK, XK(L)		
• Temperature compensation					
- Parameterizable		Yes	Yes		
- internal temperature compensation		Yes	Yes		
- external temperature compensation with compensations socket		Yes	Yes		
- external temperature compensation with Pt100		Yes	Yes		
Resistance thermometer (RTD)					
• Characteristic linearization - for resistance thermometer	Pt100, Pt200, Pt500, Pt1000, Ni100, Ni120, Ni200, Ni500, Ni1000, Cu10; (standard/climate)		No		
Characteristic linearization					
• Parameterizable	Yes	Yes	Yes		
Cable length					
• Cable length, shielded, max.	200 m	100 m	200 m	200 m	200 m
Analog value creation					
Measurement principle	integrating	integrating	integrating	integrating	integrating
Integrations and conversion time/ resolution per channel					
• Resolution with overrange (bit including sign), max.	16 bit; Two's complement	16 bit; Two's complement	16 bit; Two's complement	16 bit; Unipolar: 15/15/15/15 bits; bipolar: 15 bits + sign / 15 bits + sign / 15 bits + sign / 15 bits + sign	16 bit; Unipolar: 15/15/15/15 bits; bipolar: 15 bits + sign / 15 bits + sign / 15 bits + sign / 15 bits + sign
• Integration time, parameterizable	Yes	Yes	Yes	Yes; 10/ 16.67/ 20/ 100 ms	Yes; 23/ 72/ 83/ 95 ms
• Basic conversion time, ms	up to 4 channels: 10 ms per module, over 5 channels: 190 ms per module, 8 channels: 80 ms	Up to 4 channels: 10 ms per module, 5 channels upwards: 190 ms per module	30 / 50 / 60 / 300		10 ms (4-channel mode); 95/83/72/23 ms (8-channel mode)
• Integration time, ms			10 / 16,67 / 20 / 100		
• Interference voltage suppression for interference frequency f1 in Hz	400 / 60 / 50 Hz	400 / 60 / 50 Hz		400 / 60 / 50 / 10 Hz	400 / 60 / 50 Hz, combinations of 400, 60, 50 Hz

Technical specifications (continued)

	6ES7 331-7PF01-0AB0	6ES7 331-7PF11-0AB0	6ES7 331-7PE10-0AB0	6ES7 331-7NF00-0AB0	6ES7 331-7NF10-0AB0
Encoder Connection of signal encoders • for current measurement as 2-wire transducer • for current measurement as 4-wire transducer • for resistance measurement with 2-conductor connection • for resistance measurement with 3-conductor connection • for resistance measurement with 4-conductor connection	Yes; without resistance correction Yes Yes			Yes; with external transmitter; possible with separate supply for transmitter Yes	Yes; with external transmitter, current supply; possible with separate supply for transmitter Yes
Errors/accuracies Operational limit in overall temperature range • Voltage, relative to input area • Current, relative to input area • Impedance, relative to input area • Resistance-type thermometer, relative to input area	+/- 0,1 % +/- 1 K	+/- 1 K	+/- 1 %/K	+/- 0,1 %; +/-0.7% +/- 0,3 %; +/-0.9%	+/- 0,1 % +/- 0,1 %
Basic error limit (operational limit at 25 °C) • Voltage, relative to input area • Current, relative to input area • Impedance, relative to input area • Resistance-type thermometer, relative to input area	+/- 0,05 % +/- 0.5 K			+/- 0,05 % +/- 0,05 %	+/- 0,05 % +/- 0,05 %
Isochronous mode Isochronous operation (application synchronized up to terminal)	No	No	No	No	No
Interrupts/diagnostics/status information Alarms • Diagnostic alarm • Limit value alarm	Yes; Parameterizable per group Yes; Parameterizable	Yes; Parameterizable per group Yes; Parameterizable	Yes; channel by channel Yes; Parameterizable	Yes; Parameterizable Yes; Parameterizable, channels 0 and 2	Yes; Parameterizable Yes; Parameterizable all channels (end of cycle interrupt is also supported across modules)
Diagnostic messages • Diagnostic information readable	Yes	Yes	Yes	Yes	Yes
Galvanic isolation Galvanic isolation analog inputs • between the channels • between the channels, in groups of 2 • between the channels and the backplane bus	No 2 Yes	No 2 Yes	Yes 1 Yes	No 2 Yes	No 2 Yes
Isolation Isolation checked with	500 V DC	500 V DC	2500 V DC	500 V DC	500 V AC
Connection method required front connector	40-pin	40-pin	40-pin	40-pin	40-pin
Dimensions Width	40 mm	40 mm	40 mm	40 mm	40 mm
Height	125 mm	125 mm	125 mm	125 mm	125 mm
Depth	120 mm	120 mm	120 mm	120 mm	120 mm
Weight Weight, approx.	272 g	272 g	272 g	272 g	272 g

SIMATIC S7-300

Analog modules

SM 331 analog input modules

Ordering data

SM 331 analog input modules

Including labeling strips, bus connector, measuring range modules

8 inputs, 13-bit resolution

6ES7 331-1KF02-0AB0

8 inputs, resolution 9/12/14 bits

6ES7 331-7KF02-0AB0

2 inputs, resolution 9/12/14 bits

6ES7 331-7KB02-0AB0

8 inputs, enhanced resolution 16 bits

6ES7 331-7NF00-0AB0

8 inputs, enhanced resolution 16 bits, 4-channel mode

6ES7 331-7NF10-0AB0

8 inputs, resolution 14 bits, for isochronous mode

6ES7 331-7HF01-0AB0

6 inputs, for thermal resistors, resolution 16 bits

6ES7 331-7PE10-0AB0

8 inputs, for thermal resistors

6ES7 331-7PF01-0AB0

8 inputs, for thermoelements

6ES7 331-7PF11-0AB0

Measuring range module for analog inputs

6ES7 974-0AA00-0AA0

1 module for 2 analog inputs; 2 units (spare part)

Front connector

20-pin, with screw contacts

- 1 unit
- 100 units

6ES7 392-1AJ00-0AA0
6ES7 392-1AJ00-1AB0

20-pin, with spring-loaded contacts

- 1 unit
- 100 units

6ES7 392-1BJ00-0AA0
6ES7 392-1BJ00-1AB0

40-pin, with screw contacts

- 1 unit
- 100 units

6ES7 392-1AM00-0AA0
6ES7 392-1AM00-1AB0

40-pin, with spring-loaded contacts

- 1 unit
- 100 units

6ES7 392-1BM01-0AA0
6ES7 392-1BM01-1AB0

Front door, elevated design

6ES7 328-0AA00-7AA0

e.g. for 32-channel modules; for connecting 1.3 mm²/16 AWG wires

SIMATIC TOP connect

See page 5/224; for information about which components can be used for the respective module, see Industry Mall

Bus connectors

6ES7 390-0AA00-0AA0

1 unit (spare part)

Shield connecting element

6ES7 390-5AA00-0AA0

80 mm wide, with 2 rows for 4 terminal elements each

Terminal elements

2 units

For 2 cables with 2 mm to 6 mm diameter

6ES7 390-5AB00-0AA0

For 1 cable with 3 mm to 8 mm diameter

6ES7 390-5BA00-0AA0

For 1 cable with 4 mm to 13 mm diameter

6ES7 390-5CA00-0AA0

Label cover

10 units (spare part), for modules with 20-pin front connector

6ES7 392-2XY00-0AA0

Labeling strips

10 units (spare part), for modules with 20-pin front connector

6ES7 392-2XX00-0AA0

Labeling sheets for machine labeling

For modules with 20-pin front connector, DIN A4, for printing with laser printer; 10 units

petrol

6ES7 392-2AX00-0AA0

light-beige

6ES7 392-2BX00-0AA0

yellow

6ES7 392-2CX00-0AA0

red

6ES7 392-2DX00-0AA0

For modules with 40-pin front connector, DIN A4, for printing with laser printer; 10 units

petrol

6ES7 392-2AX10-0AA0

light-beige

6ES7 392-2BX10-0AA0

yellow

6ES7 392-2CX10-0AA0

red

6ES7 392-2DX10-0AA0

SIMATIC Manual Collection

6ES7 998-8XC01-8YE0

Electronic manuals on DVD, multilingual: LOGO!, SIMADYN, SIMATIC bus components, SIMATIC C7, SIMATIC distributed I/O, SIMATIC HMI, SIMATIC Sensors, SIMATIC NET, SIMATIC PC Based Automation, SIMATIC PCS 7, SIMATIC PG/PC, SIMATIC S7, SIMATIC Software, SIMATIC TDC

SIMATIC Manual Collection update service for 1 year

6ES7 998-8XC01-8YE2

Current "Manual Collection" DVD and the three subsequent updates

S7-300 manual

Design, CPU data, module data, instruction list

German

6ES7 398-8FA10-8AA0

English

6ES7 398-8FA10-8BA0

Overview



- Analog outputs
- For the connection of analog actuators

Technical specifications

	6ES7 332-5HB01-0AB0	6ES7 332-5HD01-0AB0	6ES7 332-5HF00-0AB0	6ES7 332-7ND02-0AB0
Supply voltage				
Load voltage L+				
• Rated value (DC)	24 V	24 V	24 V	24 V
Input current				
from load voltage L+ (without load), max.	135 mA	240 mA	340 mA	290 mA
from backplane bus 5 V DC, max.	60 mA	60 mA	100 mA	120 mA
Power losses				
Power loss, typ.	3 W	3 W	6 W	3 W
Analog outputs				
Number of analog outputs	2	4	8	4; Isochronous mode
Voltage output, short-circuit protection	Yes	Yes	Yes	Yes
Voltage output, short-circuit current, max.	25 mA	25 mA	25 mA	40 mA
Current output, no-load voltage, max.	18 V	18 V	18 V	18 V
Output ranges, voltage				
• 0 to 10 V	Yes	Yes	Yes	Yes
• 1 to 5 V	Yes	Yes	Yes	Yes
• -10 to +10 V	Yes	Yes	Yes	Yes
Output ranges, current				
• 0 to 20 mA	Yes	Yes	Yes	Yes
• -20 to +20 mA	Yes	Yes	Yes	Yes
• 4 to 20 mA	Yes	Yes	Yes	Yes
Load impedance (in rated range of output)				
• with voltage outputs, min.	1 k Ω	1 k Ω	1 k Ω	1 k Ω
• with voltage outputs, capacitive load, max.	1 μ F	1 μ F	1 μ F	1 μ F
• with current outputs, max.	500 Ω	500 Ω	500 Ω	500 Ω
• with current outputs, inductive load, max.	10 mH	10 mH	10 mH	1 mH
Cable length				
• Cable length, shielded, max.	200 m	200 m	200 m	200 m

SIMATIC S7-300

Analog modules

SM 332 analog output modules

Technical specifications (continued)

	6ES7 332-5HB01-0AB0	6ES7 332-5HD01-0AB0	6ES7 332-5HF00-0AB0	6ES7 332-7ND02-0AB0
Analog value creation				
Integrations and conversion time/ resolution per channel				
• Resolution with overrange (bit including sign), max.	12 bit; +/-10 V, +/-20 mA, 4 to 20 mA, 1 to 5 V: 11 bits + sign; 0 to 10 V, 0 to 20 mA: 12 bits	12 bit; +/-10 V, +/-20 mA, 4 to 20 mA, 1 to 5 V: 11 bits + sign; 0 to 10 V, 0 to 20 mA: 12 bits	12 bit; +/-10 V, +/-20 mA, 4 to 20 mA, 1 to 5 V: 11 bits + sign; 0 to 10 V, 0 to 20 mA: 12 bits	16 bit
• Conversion time (per channel)	0.8 ms	0.8 ms	0.8 ms	200 µs; in isochronous mode 640 µs
Settling time				
• for resistive load	0.2 ms	0.2 ms	0.2 ms	0.2 ms
• for capacitive load	3.3 ms	3.3 ms	3.3 ms	3.3 ms
• for inductive load	0.5 ms; 0.5 ms (1 mH); 3.3 ms (10 mH)	0.5 ms; 0.5 ms (1 mH); 3.3 ms (10 mH)	0.5 ms; 0.5 ms (1 mH); 3.3 ms (10 mH)	0.5 ms
Errors/accuracies				
Operational limit in overall temperature range				
• Voltage, relative to output area	+/- 0,5 %	+/- 0,5 %	+/- 0,5 %	+/- 0,12 %
• Current, relative to output area	+/- 0,6 %	+/- 0,6 %	+/- 0,6 %	+/- 0,18 %
Basic error limit (operational limit at 25 °C)				
• Voltage, relative to output area	+/- 0,4 %	+/- 0,4 %	+/- 0,4 %	+/- 0,02 %
• Current, relative to output area	+/- 0,5 %	+/- 0,5 %	+/- 0,5 %	+/- 0,02 %
Interrupts/diagnostics/status information				
Substitute values connectable	Yes; Parameterizable	Yes; Parameterizable	Yes; Parameterizable	Yes; Parameterizable
Alarms				
• Diagnostic alarm	Yes; Parameterizable	Yes; Parameterizable	Yes; Parameterizable	Yes; Parameterizable
Diagnostic messages				
• Diagnostic information readable	Yes	Yes	Yes	Yes
Galvanic isolation				
Galvanic isolation analog outputs				
• between the channels and the backplane bus	Yes	Yes	Yes	Yes
Isolation				
Isolation checked with	500 V DC	500 V DC	500 V DC	1500 V DC
Connection method				
required front connector	20-pin	20-pin	40-pin	20-pin
Dimensions				
Width	40 mm	40 mm	40 mm	40 mm
Height	125 mm	125 mm	125 mm	125 mm
Depth	120 mm	120 mm	120 mm	120 mm
Weight				
Weight, approx.	220 g	220 g	272 g	220 g

Ordering data	Order No.	Order No.
SM 332 analog output modules incl. labeling strips, bus connector 4 outputs, 11/12 bit 4 outputs, 16 bit 2 outputs, 11/12 bit 8 outputs, 11/12 bit	6ES7 332-5HD01-0AB0 6ES7 332-7ND02-0AB0 6ES7 332-5HB01-0AB0 6ES7 332-5HF00-0AB0	
Front connector 20-pin, with screw contacts • 1 unit • 100 units 20-pin, with spring-loaded contacts • 1 unit • 100 units 40-pin, with screw contacts • 1 unit • 100 units 40-pin, with spring-loaded contacts • 1 unit • 100 units	6ES7 392-1AJ00-0AA0 6ES7 392-1AJ00-1AB0 6ES7 392-1BJ00-0AA0 6ES7 392-1BJ00-1AB0 6ES7 392-1AM00-0AA0 6ES7 392-1AM00-1AB0 6ES7 392-1BM01-0AA0 6ES7 392-1BM01-1AB0	
Front door, elevated design e.g. for 32-channel modules; for connecting 1.3 mm ² /16 AWG wires	6ES7 328-0AA00-7AA0	
SIMATIC TOP connect	See page 5/224; for information about which components can be used for the respective module, see Industry Mall	
Bus connectors 1 unit (spare part)	6ES7 390-0AA00-0AA0	
Shield connecting element 80 mm wide, with 2 rows for 4 terminal elements each	6ES7 390-5AA00-0AA0	
Terminal elements 2 units for 2 cables with 2 mm to 6 mm diameter for 1 cable with 3 mm to 8 mm diameter for 1 cable with 4 mm to 13 mm diameter	6ES7 390-5AB00-0AA0 6ES7 390-5BA00-0AA0 6ES7 390-5CA00-0AA0	
Label cover 10 units (spare part), for modules with 20-pin front connector	6ES7 392-2XY00-0AA0	
Labeling strips 10 units (spare part), for modules with 20-pin front connector	6ES7 392-2XX00-0AA0	
	Labeling sheets for machine labeling for modules with 20-pin front connector, DIN A4, for printing with laser printer; 10 units petrol light-beige yellow red for modules with 40-pin front connector, DIN A4, for printing with laser printer; 10 units petrol light-beige yellow red SIMATIC Manual Collection Electronic manuals on DVD, multilingual: LOGO!, SIMADYN, SIMATIC bus components, SIMATIC C7, SIMATIC distributed I/O, SIMATIC HMI, SIMATIC Sensors, SIMATIC NET, SIMATIC PC Based Automation, SIMATIC PCS 7, SIMATIC PG/PC, SIMATIC S7, SIMATIC Software, SIMATIC TDC SIMATIC Manual Collection update service for 1 year Current "Manual Collection" DVD and the three subsequent updates S7-300 manual Design, CPU data, module data, instruction list German English	6ES7 392-2AX00-0AA0 6ES7 392-2BX00-0AA0 6ES7 392-2CX00-0AA0 6ES7 392-2DX00-0AA0 6ES7 392-2AX10-0AA0 6ES7 392-2BX10-0AA0 6ES7 392-2CX10-0AA0 6ES7 392-2DX10-0AA0 6ES7 998-8XC01-8YE0 6ES7 998-8XC01-8YE2
		6ES7 398-8FA10-8AA0 6ES7 398-8FA10-8BA0

SIMATIC S7-300

Analog modules

SM 334 analog input/output modules

Overview



- Analog inputs and outputs
- For the connection of analog sensors and actuators

5

Technical specifications

	6ES7 334-0CE01-0AA0	6ES7 334-0KE00-0AB0
Supply voltage		
Load voltage L+		
• Rated value (DC)	24 V	24 V
Input current		
from load voltage L+ (without load), max.	110 mA	80 mA
from backplane bus 5 V DC, max.	55 mA	60 mA
Power losses		
Power loss, typ.	3 W	2 W
Analog inputs		
Number of analog inputs	4	4
Number of analog inputs for voltage measurement	4	2
Number of analog inputs for resistance measurement		4
permissible input voltage for voltage input (destruction limit), max.	20 V	20 V; continuous; 75 V for max. 1 s (mark to space ratio 1:20)
permissible input current for current input (destruction limit), max.	40 mA	
Cycle time (all channels) max.	5 ms	85 ms
Input ranges (rated values), voltages		
• 0 to +10 V	Yes	Yes
Input ranges (rated values), currents		
• 0 to 20 mA	Yes	
Input ranges (rated values), resistance thermometers		
• Pt 100		Yes; only climatic range
Input ranges (rated values), resistors		
• 0 to 10000 ohms		Yes
Analog outputs		
Number of analog outputs	2	2
Voltage output, short-circuit protection	Yes	Yes
Voltage output, short-circuit current, max.	11 mA	10 mA
Current output, no-load voltage, max.	15 V	
Output ranges, voltage		
• 0 to 10 V	Yes	Yes
Output ranges, current		
• 0 to 20 mA	Yes	

Technical specifications (continued)

	6ES7 334-0CE01-0AA0	6ES7 334-0KE00-0AB0
Load impedance (in rated range of output) <ul style="list-style-type: none"> • with voltage outputs, min. • with voltage outputs, capacitive load, max. • with current outputs, max. • with current outputs, inductive load, max. 	5 kΩ 1 μF 300 Ω 1 mH	2.5 kΩ 1 μF
Cable length <ul style="list-style-type: none"> • Cable length, shielded, max. 	200 m	100 m
Analog value creation Integrations and conversion time/ resolution per channel <ul style="list-style-type: none"> • Resolution with overrange (bit including sign), max. • Integration time, ms 	8 bit	12 bit 16.67/20 ms
Settling time <ul style="list-style-type: none"> • for resistive load • for capacitive load • for inductive load 	0.3 ms 3 ms 0.3 ms	0.8 ms 0.8 ms
Encoder Connection of signal encoders <ul style="list-style-type: none"> • for current measurement as 4-wire transducer • for resistance measurement with 2-conductor connection • for resistance measurement with 3-conductor connection • for resistance measurement with 4-conductor connection 	Yes	Yes Yes Yes
Errors/accuracies Operational limit in overall temperature range <ul style="list-style-type: none"> • Voltage, relative to input area • Current, relative to input area • Impedance, relative to input area • Resistance-type thermometer, relative to input area • Voltage, relative to output area • Current, relative to output area 	+/- 0,9 % +/- 0,8 % +/- 0,6 % +/- 1 %	+/- 0,7 %; 0 to 10 V +/- 3,5 %; 10 kOhm +/- 1 % +/- 1 %
Basic error limit (operational limit at 25 °C) <ul style="list-style-type: none"> • Voltage, relative to input area • Current, relative to input area • Impedance, relative to input area • Resistance-type thermometer, relative to input area • Voltage, relative to output area • Current, relative to output area 	+/- 0,7 % +/- 0,6 % +/- 0,5 % +/- 0,5 %	+/- 0,5 %; 0 to 10 V +/- 2,8 %; 10 kOhm +/- 0,8 % +/- 0,85 %
Interrupts/diagnostics/status information Alarms <ul style="list-style-type: none"> • Alarms 	No	No
Diagnostic messages <ul style="list-style-type: none"> • Diagnostic functions 	No	No

SIMATIC S7-300

Analog modules

SM 334 analog input/output modules

Technical specifications (continued)

	6ES7 334-0CE01-0AA0	6ES7 334-0KE00-0AB0
Galvanic isolation		
Galvanic isolation analog inputs		
• between the channels and the backplane bus	No	Yes
Galvanic isolation analog outputs		
• between the channels and the backplane bus	No	Yes
Isolation		
Isolation checked with	500 V DC	500 V DC
Connection method		
required front connector	20-pin	20-pin
Dimensions		
Width	40 mm	40 mm
Height	125 mm	125 mm
Depth	120 mm	120 mm
Weight		
Weight, approx.	285 g	200 g

Ordering data

SM 334 analog input/output modules

incl. labeling strips, bus connector

4 inputs, 2 outputs

6ES7 334-0CE01-0AA0

4 inputs, 2 outputs, resistance measurement, Pt 100

6ES7 334-0KE00-0AB0

Front connector

20-pin, with screw contacts

- 1 unit
- 100 units

6ES7 392-1AJ00-0AA0

6ES7 392-1AJ00-1AB0

20-pin, with spring-loaded terminals

- 1 unit
- 100 units

6ES7 392-1BJ00-0AA0

6ES7 392-1BJ00-1AB0

Front door, elevated design

e.g. for 32-channel modules; for connecting 1.3 mm²/16 AWG wires

6ES7 328-0AA00-7AA0

SIMATIC TOP connect

See page 5/224; for information about which components can be used for the respective module, see Industry Mall

Bus connectors

1 unit (spare part)

6ES7 390-0AA00-0AA0

Shield connecting element

80 mm wide, with 2 rows for 4 terminal elements each

6ES7 390-5AA00-0AA0

Terminal elements

2 units

for 2 cables with 2 mm to 6 mm diameter

6ES7 390-5AB00-0AA0

for 1 cable with 3 mm to 8 mm diameter

6ES7 390-5BA00-0AA0

for 1 cable with 4 mm to 13 mm diameter

6ES7 390-5CA00-0AA0

Label cover

10 units (spare part), for modules with 20-pin front connector

6ES7 392-2XY00-0AA0

Labeling strips

10 units (spare part), for modules with 20-pin front connector

6ES7 392-2XX00-0AA0

Labeling sheets for machine labeling

for modules with 20-pin front connector, DIN A4, for printing with laser printer; 10 units

petrol

6ES7 392-2AX00-0AA0

light-beige

6ES7 392-2BX00-0AA0

yellow

6ES7 392-2CX00-0AA0

red

6ES7 392-2DX00-0AA0

SIMATIC Manual Collection

Electronic manuals on DVD, multilingual: LOGO!, SIMADYN, SIMATIC bus components, SIMATIC C7, SIMATIC distributed I/O, SIMATIC HMI, SIMATIC Sensors, SIMATIC NET, SIMATIC PC Based Automation, SIMATIC PCS 7, SIMATIC PG/PC, SIMATIC S7, SIMATIC Software, SIMATIC TDC

6ES7 998-8XC01-8YE0

SIMATIC Manual Collection update service for 1 year

Current "Manual Collection" DVD and the three subsequent updates

6ES7 998-8XC01-8YE2

S7-300 manual

Design, CPU data, module data, instruction list

German

6ES7 398-8FA10-8AA0

English

6ES7 398-8FA10-8BA0

Overview



- Analog inputs
- For connecting voltage sensors and current sensors, thermocouples, resistors and resistance thermometers

Note:

SIPLUS extreme products are based on Siemens Industry standard products. The contents listed here were taken from the respective standard products. SIPLUS extreme specific information was added.

SIPLUS SM 331	8 AI, 1 X 40-pin	8 AI, 1 X 40-pin	2 AI, 1 X 20-pin
Order number	6AG1 331-1KF02-4AB0	6AG1 331-1KF02-7AB0	6AG1 331-7KB02-2AB0
Order No. based on	6ES7 331-1KF02-0AB0	6ES7 331-1KF02-0AB0	6ES7 331-7KB02-0AB0
Ambient temperature range	0 ... +60 °C	-25 ... +70 °C	-25 ... +70 °C
Compliant with the standards for electronic equipment used on rolling stock (EN 50155, temperature T1, category 1).	No	No	No
Conformal coating	Coating of the printed circuit boards and the electronic components		
Technical data	The technical data of the standard product applies except for the ambient conditions.		
SIPLUS SM 331	8 AI, 1 X 20-pin	8 AI, 1 X 40-pin	8 AI, 1 X 20-pin
Order number	6AG1 331-7KF02-2AB0	6AG1 331-7NF00-2AB0	6AG1 331-7NF10-2AB0
Order No. based on	6ES7 331-7KF02-0AB0	6ES7 331-7NF00-0AB0	6ES7 331-7NF10-0AB0
Ambient temperature range	-25 ... +70 °C	-25 ... +70 °C	-25 ... +60 °C
Compliant with the standards for electronic equipment used on rolling stock (EN 50155, temperature T1, category 1).	Yes	Yes	No
Conformal coating	Coating of the printed circuit boards and the electronic components		
Technical data	The technical data of the standard product applies except for the ambient conditions.		
SIPLUS SM 331	8 AI, 1 X 40-pin	8 AI, 1 X 40-pin	
Order number	6AG1 331-7PF01-4AB0	6AG1 331-7PF11-4AB0	
Order No. based on	6ES7 331-7PF01-0AB0	6ES7 331-7PF11-0AB0	
Ambient temperature range	0 ... +60 °C	0 ... +60 °C	
Compliant with the standards for electronic equipment used on rolling stock (EN 50155, temperature T1, category 1).	No	No	
Conformal coating	Coating of the printed circuit boards and the electronic components		
Technical data	The technical data of the standard product applies except for the ambient conditions.		

SIMATIC S7-300

SIPLUS analog modules

SIPLUS SM 331 analog input modules

Overview (continued)

Ambient conditions

Relative humidity	100%, condensation/frost permissible. No commissioning if condensation present.
Biologically active substances, compliance with EN 60721-3-3	Class 3B2 mold and fungal spores (excluding fauna). The supplied plug covers must remain in place over the unused interfaces during operation!
Chemically active substances, compliance with EN 60721-3-3	Class 3C4 incl. salt spray in accordance with EN 60068-2-52 (degree of severity 3). The supplied plug covers must remain in place over the unused interfaces during operation!
Mechanically active substances, compliance with EN 60721-3-3	Class 3S4 incl. sand, dust. The supplied plug covers must remain in place over the unused interfaces during operation!
Air pressure (depending on the highest positive temperature range specified)	1080 ... 795 hPa (-1000 ... +2000 m) see ambient temperature range 795 ... 658 hPa (+2000 ... +3500 m) derating 10 K 658 ... 540 hPa (+3500 ... +5000 m) derating 20 K

For technical documentation on SIPLUS, see:
www.siemens.com/siplus-extreme

Ordering data

Order No.

SIPLUS SM 331 analog input modules

(extended temperature range and medial exposure)

Including labeling strips, bus connector, measuring range modules

8 inputs, resolution 13 bit; only medial exposure

6AG1 331-1KF02-4AB0

8 inputs, resolution 13 bit

6AG1 331-1KF02-7AB0

2 inputs, resolution 9/12/14 bit

6AG1 331-7KB02-2AB0

8 inputs, resolution 9/12/14 bit

6AG1 331-7KF02-2AB0

8 inputs, enhanced resolution 16 bit

6AG1 331-7NF00-2AB0

8 inputs, enhanced resolution 16 bit, 4-channel mode

6AG1 331-7NF10-2AB0

8 inputs, for thermal resistors

6AG1 331-7PF01-4AB0

8 inputs, for thermocouples

6AG1 331-7PF11-4AB0

Accessories

See SIMATIC S7-300 analog input modules, page 5/76

Overview



- Analog outputs
- For connection of analog actuators

Note:

SIPLUS extreme products are based on Siemens Industry standard products. The contents listed here were taken from the respective standard products. SIPLUS extreme specific information was added.

SIPLUS SM 332	2 AO 1 X 20-pin	4 AO 1 X 20-pin	8 AO 1 X 40-pin
Order number	6AG1 332-5HB01-2AB0	6AG1 332-5HD01-7AB0	6AG1 332-5HF00-2AB0
Order No. based on	6ES7 332-5HB01-0AB0	6ES7 332-5HD01-0AB0	6ES7 332-5HF00-0AB0
Ambient temperature range	-25 ... +70 °C	-25 ... +70 °C	-25 ... +70 °C
Compliant with the standards for electronic equipment used on rolling stock (EN 50155, temperature T1, category 1).	Yes	No	No
Conformal coating	Coating of the printed circuit boards and the electronic components		
Technical data	The technical data of the standard product applies except for the ambient conditions.		
SIPLUS SM 332	8 AO 1 X 40-pin	4 AO 1 X 20-pin	
Order number	6AG1 332-5HF00-4AB0	6AG1332-7ND02-4AB0	
Order No. based on	6ES7 332-5HF00-0AB0	6ES7 332-7ND02-0AB0	
Ambient temperature range	0 ... +60 °C	0 ... +60 °C	
Compliant with the standards for electronic equipment used on rolling stock (EN 50155, temperature T1, category 1).	No	No	
Conformal coating	Coating of the printed circuit boards and the electronic components		
Technical data	The technical data of the standard product applies except for the ambient conditions.		

SIMATIC S7-300

SIPLUS analog modules

SIPLUS SM 332 analog output modules

Overview (continued)

Ambient conditions

Relative humidity	100%, condensation/frost permissible. No commissioning if condensation present.
Biologically active substances, compliance with EN 60721-3-3	Class 3B2 mold and fungal spores (excluding fauna). The supplied plug covers must remain in place over the unused interfaces during operation!
Chemically active substances, compliance with EN 60721-3-3	Class 3C4 incl. salt spray in accordance with EN 60068-2-52 (degree of severity 3). The supplied plug covers must remain in place over the unused interfaces during operation!
Mechanically active substances, compliance with EN 60721-3-3	Class 3S4 incl. sand, dust. The supplied plug covers must remain in place over the unused interfaces during operation!
Air pressure (depending on the highest positive temperature range specified)	1080 ... 795 hPa (-1000 ... +2000 m) see ambient temperature range 795 ... 658 hPa (+2000 ... +3500 m) derating 10 K 658 ... 540 hPa (+3500 ... +5000 m) derating 20 K

For technical documentation on SIPLUS, see:
www.siemens.com/siplus-extreme

Ordering data

SIPLUS SM 332 analog output modules

(extended temperature range and medial exposure)

incl. labeling strips, bus connector

4 outputs, 11/12 bit

4 outputs, 16 bit;
only medial exposure

2 outputs, 11/12 bit

8 outputs, 11/12 bit

8 outputs, 11/12 bit;
only medial exposure

Accessories

Order No.

6AG1 332-5HD01-7AB0

6AG1 332-7ND02-4AB0

6AG1 332-5HB01-2AB0

6AG1 332-5HF00-2AB0

6AG1 332-5HF00-4AB0

See SIMATIC S7-300 analog output modules, page 5/79

SIMATIC S7-300

SIPLUS analog modules

SIPLUS SM 334 analog input/output modules

Overview



- Analog inputs and outputs
- For connection of analog sensors and actuators

Note:

SIPLUS extreme products are based on Siemens Industry standard products. The contents listed here were taken from the respective standard products. SIPLUS extreme specific information was added.

SIPLUS SM 334	2 AO
Order number	6AG1 334-0KE00-7AB0
Order No. based on	6ES7 334-0KE00-0AB0
Ambient temperature range	-25 ... +70 °C
Conformal coating	Coating of the printed circuit boards and the electronic components
Technical data	The technical data of the standard product applies except for the ambient conditions.
Compliant with the standards for electronic equipment used on railway rolling stock (EN 50155, temperature T1, category 1).	No
Ambient conditions	
Relative humidity	100%, condensation/frost permissible. No commissioning if condensation present.
Biologically active substances, compliance with EN 60721-3-3	Class 3B2 mold and fungal spores (excluding fauna). The supplied plug covers must remain in place over the unused interfaces during operation!
Chemically active substances, compliance with EN 60721-3-3	Class 3C4 incl. salt spray in accordance with EN 60068-2-52 (degree of severity 3). The supplied plug covers must remain in place over the unused interfaces during operation!
Mechanically active substances, compliance with EN 60721-3-3	Class 3S4 incl. sand, dust. The supplied plug covers must remain in place over the unused interfaces during operation!
Air pressure (depending on the highest positive temperature range specified)	1080 ... 795 hPa (-1000 ... +2000 m) see ambient temperature range 795 ... 658 hPa (+2000 ... +3500 m) derating 10 K 658 ... 540 hPa (+3500 ... +5000 m) derating 20 K

For technical documentation on SIPLUS, see:
www.siemens.com/siplus-extreme

Ordering data	Order No.
SIPLUS SM 334 analog input/output modules (extended temperature range and medial exposure) incl. labeling strips, bus connector 4 inputs, 2 outputs, resistance measurement, Pt 100	6AG1 334-0KE00-7AB0
Accessories	

SIMATIC S7-300

F digital / analog modules

SM 326 F digital input modules - Safety Integrated

Overview



- Digital inputs for the fail-safe SIMATIC S7 systems
- For connecting:
 - Switches and 2-wire proximity switches
 - Sensors according to NAMUR and mechanical contacts, also for signals from hazardous areas
- With integral safety functions for fail-safe operation
- Can be used in fail-safe operation
 - Centrally: with S7-31xF-2 DP
 - Distributed in ET 200M: with SIMATIC IM 151-7 F-CPU, S7-31xF-2 DP, S7-416F-2 and S7-400F/FH
- In standard operation can be used in the same way as S7-300 modules

Technical specifications

	6ES7 326-1RF00-0AB0	6ES7 326-1BK02-0AB0
Supply voltage		
Rated value (DC)	24 V	24 V
Input current		
from load voltage L+ (without load), max.	160 mA	450 mA
from backplane bus 5 V DC, max.	90 mA	100 mA
Encoder supply		
Number of outputs	8	4; Isolated
Output voltage	8.2 V DC	
Output current, rated value		400 mA
Power losses		
Power loss, typ.	4.5 W	10 W
Digital inputs		
Number/binary inputs	8; 8 (one-channel); 4 (two-channel)	24
Number of simultaneously controllable inputs		
• all mounting positions		
- up to 40 °C, max.	8; vertical setup	24
- up to 60 °C, max.	8; horizontal set up	24; (at 24 V) or 18 (at 28.8 V)
Input voltage		
• Type of input voltage	DC	
• Rated value, DC	in accordance with DIN 19234 or NAMUR	24 V
• for signal "0"		-30 to +5 V
• for signal "1"		11 to 30 V
Input current		
• for signal "0", max. (permissible quiescent current)	0.35 to 1.2 mA	2 mA
• for signal "1", typ.	2.1 to 7 mA	10 mA
Input delay (for rated value of input voltage)		
• for standard inputs		
- at "0" to "1", max.		3.4 ms
- at "1" to "0", max.		3.4 ms
• for NAMUR inputs		
- at "0" to "1", max.	1.2 to 3 ms	
- at "1" to "0", max.	1.2 to 3 ms	
Cable length		
• Cable length, shielded, max.	200 m	200 m
• Cable length unshielded, max.	100 m	100 m

Technical specifications (continued)

	6ES7 326-1RF00-0AB0	6ES7 326-1BK02-0AB0
Encoder		
Connectable encoders		
<ul style="list-style-type: none"> • 2-wire sensor - Permissible quiescent current (2-wire sensor), max. 		Yes; if short-circuit test is deactivated 2 mA
Interrupts/diagnostics/status information		
Alarms		
<ul style="list-style-type: none"> • Diagnostic alarm 	Yes	Yes
Diagnostic messages		
<ul style="list-style-type: none"> • Diagnostic information readable 	Yes	Yes
Ex(i) characteristics		
Module for Ex(i) protection	Yes	
Max. values of input circuits (per channel)		
<ul style="list-style-type: none"> • Co (permissible external capacity), max. • Io (short-circuit current), max. • Lo (permissible external inductivity), max. • Po (power of load), max. • Uo (output no-load voltage), max. • Um (fault voltage), max. • Ta (permissible ambient temperature), max. 	3 µF 13.9 mA 80 mH 33.1 mW 10 V 60 V DC/30 V AC 60 °C	60 °C
Galvanic isolation		
Galvanic isolation digital inputs		
<ul style="list-style-type: none"> • between the channels • between the channels, in groups of • between the channels and the back-plane bus 	Yes Yes Yes	Yes 12 Yes
Isolation		
Isolation checked with	500 V DC	500 V DC / 350 V AC
Standards, approvals, certificates		
Highest safety class achievable in safety mode		
<ul style="list-style-type: none"> • acc. to DIN VDE 0801 • acc. to EN 954 • acc. to IEC 61508 	AK 4 (one channel), AK 5 und 6 (two channel) 4 SIL 2 (single-channel), SIL 3 (two-channel)	AK 6 SIL 3
Use in hazardous areas		
<ul style="list-style-type: none"> • Test number KEMA 	99 ATEX 2671 X	
Connection method		
required front connector	40-pin	40-pin
Dimensions		
Width	80 mm	80 mm
Height	125 mm	125 mm
Depth	120 mm	120 mm
Weight		
Weight, approx.	482 g	442 g

SIMATIC S7-300

F digital / analog modules

SM 326 F digital input modules - Safety Integrated

Ordering data	Order No.	Order No.
SM 326 F digital input module 24 inputs, 24 V DC 8 inputs, 24 V DC, NAMUR	6ES7 326-1BK02-0AB0 6ES7 326-1RF00-0AB0	
S7 Distributed Safety V5.4 programming tool Task: Configuration software for configuring fail-safe user programs for SIMATIC S7-300F, S7-400F, ET 200S Requirement: STEP 7 V5.3 SP3 and higher Floating License Floating license for 1 user, license key download without software or documentation ¹⁾ ; email address required for delivery	6ES7 833-1FC02-0YA5 6ES7 833-1FC02-0YH5	Active bus module BM 1 x 80 for 1 module with 80 mm width SITOP power supply module For ET 200M; 120/230 V AC, 24 V DC, 5 A; Type PS 307-1E Front connectors 40-pin, with screw contacts • 1 unit • 100 units 40-pin, with spring-loaded contacts • 1 unit • 100 units Front door, higher version, for F-modules For F-modules; for connecting 1.3 mm ² /16 AWG wires; wiring diagram and labels in yellow
S7 Distributed Safety upgrade From V5.x to V5.4; Floating license for 1 user	6ES7 833-1FC02-0YE5	Labeling strips For fail-safe modules (spare part); 10 units Label cover For fail-safe modules (spare part); 10 units LK 393 cable guide For F modules; L+ and M connections; 5 units S7-300 manual Design, CPU data, module data, instruction list German English
STEP 7 Safety Advanced V11 Task: Engineering tool for configuring fail-safe user programs for SIMATIC S7-300F, S7-400F, WinAC RTX F, ET 200S, ET 200M, ET 200iSP, ET 200pro, ET 200eco Requirement: STEP 7 Professional V11 SP1 Floating license for 1 user Floating license for 1 user, license key download without software or documentation ¹⁾ ; email address required for delivery	6ES7 833-1FA11-0YA5 6ES7 833-1FA11-0YH5	SIMATIC Manual Collection Electronic manuals on DVD, multilingual: LOGO!, SIMADYN, SIMATIC bus components, SIMATIC C7, SIMATIC distributed I/O, SIMATIC HMI, SIMATIC Sensors, SIMATIC NET, SIMATIC PC Based Automation, SIMATIC PCS 7, SIMATIC PG/PC, SIMATIC S7, SIMATIC Software, SIMATIC TDC SIMATIC Manual Collection update service for 1 year Current "Manual Collection" DVD and the three subsequent updates
STEP 7 Safety Advanced Upgrade Distributed Safety V5.4 SP5 and STEP 7 Safety Advanced V11 for parallel use; incl. software on CD; Combo License for 1 user Distributed Safety V5.4 SP5 and STEP 7 Safety Advanced V11 for parallel use; includes software on CD; combo license for 1 user, license key download without software or documentation ¹⁾ ; email address required for delivery	6ES7 833-1FA11-0YE5 6ES7 833-1FA11-0YK5	
DIN rail for active bus modules For max. 5 active bus modules for hot swapping function • 483 mm (19") long • 530 mm long • 620 mm long • 2000 mm long	6ES7 195-1GA00-0XA0 6ES7 195-1GF30-0XA0 6ES7 195-1GG30-0XA0 6ES7 195-1GC00-0XA0	

¹⁾ For up-to-date information and download availability, see: www.siemens.com/tia-online-software-delivery

SIMATIC S7-300

F digital / analog modules

SM 326 F digital output modules -
Safety Integrated

Overview



- Digital outputs for the fail-safe SIMATIC S7 systems
- Two versions (1 x current sourcing, 1 x current sinking)
- For connecting solenoid valves, DC contactors and indicator lights
- With integral safety functions for fail-safe operation
- Can be used in fail-safe operation
 - Centrally: with S7-31xF DP, S7-31xF PN/DP
 - Distributed in ET 200M: with SIMATIC IM 151-7 F-CPU, S7-31xF-2 DP, S7-41xF-2 and S7-400F/FH

5

Technical specifications

	6ES7 326-2BF10-0AB0	6ES7 326-2BF41-0AB0
Supply voltage		
Load voltage L+		
• Rated value (DC)	24 V; 1L+, 2L+, 3L+	24 V; 1L+, 2L+, 3L+
Input current		
from load voltage 1L+, max.	100 mA; from supply voltage	75 mA; from supply voltage
from load voltage 2L+ (without load), max.	100 mA	100 mA
from load voltage 3L+ (without load), max.	100 mA	100 mA
from backplane bus 5 V DC, max.	100 mA	100 mA
Power losses		
Power loss, typ.	6 W	12 W
Digital outputs		
Number/binary outputs	10	8
Functionality/short-circuit strength	Yes; Electronic	Yes; Electronic
Limitation of inductive shutdown voltage to		L+ (-33 V)
Lamp load, max.	5 W	5 W
Output voltage		
• for signal "1" without series diode, min.		L+ (-1.0 V)
Output current		
• for signal "1" rated value	2 A	2 A
• for signal "1" permissible range for 0 to 40 °C, min.	7 mA	7 mA
• for signal "1" permissible range for 0 to 40 °C, max.	2.4 A	2 A; 2 A for horizontal installation, 1 A for vertical installation
• for signal "1" permissible range for 40 to 60 °C, min.	7 mA	7 mA
• for signal "1" permissible range for 40 to 60 °C, max.	2.4 A	1 A; for horizontal installation
• for signal "0" residual current, max.	0.5 mA	0.5 mA
Switching frequency		
• with resistive load, max.	25 Hz	30 Hz
• with inductive load, max.	25 Hz	2 Hz
• on lamp load, max.	10 Hz	10 Hz
Aggregate current of outputs (per group)		
• horizontal installation		
- up to 40 °C, max.	10 A	7.5 A
- up to 60 °C, max.	6 A	5 A
• vertical installation		
- up to 40 °C, max.	5 A	5 A
Cable length		
• Cable length, shielded, max.	1 000 m	200 m; 200 m for SIL3, AK 6, Cat 4
• Cable length unshielded, max.	600 m	200 m

SIMATIC S7-300

F digital / analog modules

SM 326 F digital output modules - Safety Integrated

Technical specifications (continued)

	6ES7 326-2BF10-0AB0	6ES7 326-2BF41-0AB0
Interrupts/diagnostics/status information		
Alarms		
• Diagnostic alarm	Yes	Yes; Parameterizable
Diagnostic messages		
• Diagnostic information readable	Yes	Yes
Galvanic isolation		
Galvanic isolation digital outputs		
• between the channels	Yes	Yes
• between the channels, in groups of	5	4
• between the channels and the backplane bus	Yes	Yes
• between the channels and the power supply of the electronics	Yes	Yes
Isolation		
Isolation checked with	370 V for 1 min	500 V DC / 350 V AC
Standards, approvals, certificates		
Highest safety class achievable in safety mode		
• acc. to DIN VDE 0801	AK 5 and 6	
• acc. to IEC 61508	SIL 3	SIL 3
Connection method		
required front connector	40-pin	40-pin
Dimensions		
Width	40 mm	80 mm
Height	125 mm	125 mm
Depth	120 mm	120 mm
Weight		
Weight, approx.	330 g	465 g

SIMATIC S7-300

F digital / analog modules

SM 326 F digital output modules - Safety Integrated

Ordering data	Order No.	Order No.
SM 326 F digital output module 10 outputs, 24 V DC, 2 A PP; width 40 mm 8 outputs, 24 V DC, 2 A PM; width 80 mm	6ES7 326-2BF10-0AB0 6ES7 326-2BF41-0AB0	SITOP power supply module For ET 200M; 120/230 V AC, 24 V DC, 5 A; Type PS 307-1E 6ES7 307-1EA01-0AA0
S7 Distributed Safety V5.4 programming tool Task: Configuration software for configuring fail-safe user programs for SIMATIC S7-300F, S7-400F, ET 200S Requirement: STEP 7 V5.3 SP3 and higher Floating License Floating license for 1 user, license key download without software or documentation ¹⁾ ; email address required for delivery	6ES7 833-1FC02-0YA5 6ES7 833-1FC02-0YH5	Front connectors 40-pin, with screw contacts • 1 unit • 100 units 40-pin, with spring-loaded contacts • 1 unit • 100 units Front door, higher version, for F-modules For F-modules; for connecting 1.3 mm ² /16 AWG wires; wiring diagram and labels in yellow
S7 Distributed Safety upgrade From V5.x to V5.4; Floating license for 1 user	6ES7 833-1FC02-0YE5	Labeling strips For fail-safe modules (spare part), 10 units Label cover For fail-safe modules (spare part), 10 units
STEP 7 Safety Advanced V11 Task: Engineering tool for configuring fail-safe user programs for SIMATIC S7-300F, S7-400F, WinAC RTX F, ET 200S, ET 200M, ET 200iSP, ET 200pro, ET 200eco Requirement: STEP 7 Professional V11 SP1 Floating license for 1 user Floating license for 1 user, license key download without software or documentation ¹⁾ ; email address required for delivery	6ES7 833-1FA11-0YA5 6ES7 833-1FA11-0YH5	LK 393 cable guide For F modules; L+ and M connections, 5 units S7-300 manual Design, CPU data, module data, instruction list German English
STEP 7 Safety Advanced Upgrade Distributed Safety V5.4 SP5 and STEP 7 Safety Advanced V11 for parallel use; incl. software on CD; Combo License for 1 user Distributed Safety V5.4 SP5 and STEP 7 Safety Advanced V11 for parallel use; includes software on CD; combo license for 1 user, license key download without software or documentation ¹⁾ ; email address required for delivery	6ES7 833-1FA11-0YE5 6ES7 833-1FA11-0YK5	SIMATIC Manual Collection Electronic manuals on DVD, multilingual: LOGO!, SIMADYN, SIMATIC bus components, SIMATIC C7, SIMATIC distributed I/O, SIMATIC HMI, SIMATIC Sensors, SIMATIC NET, SIMATIC PC Based Automation, SIMATIC PCS 7, SIMATIC PG/PC, SIMATIC S7, SIMATIC Software, SIMATIC TDC
DIN rail for active bus modules For max. 5 active bus modules, for function "Insertion and removal" • 483 mm (19") long • 530 mm long • 620 mm long • 2000 mm long	6ES7 195-1GA00-0XA0 6ES7 195-1GF30-0XA0 6ES7 195-1GG30-0XA0 6ES7 195-1GC00-0XA0	SIMATIC Manual Collection update service for 1 year Current "Manual Collection" DVD and the three subsequent updates
Active bus modules BM 2 x 40 for accepting 2 IO modules each 40 mm wide BM 1 x 80 for accepting 1 IO module 80 mm wide	6ES7 195-7HB00-0XA0 6ES7 195-7HC00-0XA0	

¹⁾ For up-to-date information and download availability, see: www.siemens.com/tia-online-software-delivery

SIMATIC S7-300

F digital / analog modules

SM 336 F analog input modules - Safety Integrated

Overview



- Analog inputs for the fail-safe SIMATIC S7 systems
- Applicable in the ET 200M distributed I/O device with IM 153-2 HF as well as centrally with SIMATIC S7-31xF-2 DP
- Properties of the SM 336; F-AI 6 x 0/4 - 20 mA HART:
 - 6 analog inputs with galvanic isolation between channels and backplane bus
 - Input ranges: 0 to 20 mA, 4 to 20 mA
 - Short-circuit proof power supply from 2 or 4-wire transducer via the module
 - External encoder supply possible
 - Applicable in safety mode
 - HART communication
 - Firmware update using HW Config
 - Identification data

5

Technical specifications

Order No.	6ES7 336-4GE00-0AB0
Product-type designation	SM 336 F-AI 6x0/4 to 20 mA HART
Supply voltage	
Load voltage L+	24 V
• Rated value (DC)	Yes
• Reverse polarity protection	Yes
Input current	
from backplane bus 5 V DC, max.	90 mA
from supply voltage L+, max.	150 mA; Typical
Power losses	
Power loss, typ.	4.5 W
Analog inputs	
Number of analog inputs	6
permissible input current for current input (destruction limit), max.	40 mA
Input ranges (rated values), currents	
• 0 to 20 mA	Yes
• 4 to 20 mA	Yes
Cable length	
• Cable length, shielded, max.	1 000 m
Analog value creation	
Integrations and conversion time/ resolution per channel	
• Resolution with overrange (bit including sign), max.	16 bit; 15 bits + sign
• Integration time, ms	20 at 50 Hz 16.7 at 60 Hz
• Interference voltage suppression for interference frequency f1 in Hz	f=n x (f1±0.5%)
Encoder	
Connection of signal encoders	
• for current measurement as 2-wire transducer	Yes
• for current measurement as 4-wire transducer	Yes

Order No.	6ES7 336-4GE00-0AB0
Product-type designation	SM 336 F-AI 6x0/4 to 20 mA HART
Errors/accuracies	
Operational limit in overall temperature range	
• Current, relative to input area	+/- 0,2 %; 40 µA
Basic error limit (operational limit at 25 °C)	
• Current, relative to input area	+/- 0,1 %
Interrupts/diagnostics/status information	
Alarms	
• Diagnostic alarm	Yes
Diagnostic messages	
• Diagnostic information readable	Yes
Galvanic isolation	
Galvanic isolation analog inputs	
• between the channels	Yes
• between the channels and the backplane bus	Yes
• between the channels and the power supply of the electronics	Yes
Isolation	
Isolation checked with	370 V for 1 min
Standards, approvals, certificates	
Highest safety class achievable in safety mode	
• acc. to DIN V 19250	old 4
• acc. to EN 954	SIL 3
• acc. to IEC 61508	
Connection method	
required front connector	20-pin
Dimensions	
Width	40 mm
Height	125 mm
Depth	120 mm
Weight	
Weight, approx.	350 g

Ordering data	Order No.	Order No.
SM 336 F analog input module 6 inputs, 15 bit, 0/4 - 20 mA HART	6ES7 336-4GE00-0AB0	SITOP power supply module For ET 200M; 120/230 V AC, 24 V DC, 5 A; Type PS 307-1E
S7 Distributed Safety V5.4 programming tool Task: Configuration software for configuring fail-safe user programs for SIMATIC S7-300F, S7-400F, ET 200S Requirement: STEP 7 V5.3 SP3 and higher Floating License Floating license for 1 user, license key download without software or documentation ¹⁾ ; email address required for delivery	6ES7 833-1FC02-0YA5 6ES7 833-1FC02-0YH5	Front connector 20-pin, with screw contacts • 1 unit • 100 units 20-pin, with spring-loaded contacts • 1 unit • 100 units
S7 Distributed Safety upgrade From V5.x to V5.4; Floating license for 1 user	6ES7 833-1FC02-0YE5	Front door, higher version, for F-modules For F-modules; for connecting 1.3 mm ² /16 AWG wires; wiring diagram and labels in yellow
STEP 7 Safety Advanced V11 Task: Engineering tool for configuring fail-safe user programs for SIMATIC S7-300F, S7-400F, WinAC RTX F, ET 200S, ET 200M, ET 200iSP, ET 200pro, ET 200eco Requirement: STEP 7 Professional V11 SP1 Floating license for 1 user Floating license for 1 user, license key download without software or documentation ¹⁾ ; email address required for delivery	6ES7 833-1FA11-0YA5 6ES7 833-1FA11-0YH5	Labeling strips For fail-safe modules (spare part), 10 units
STEP 7 Safety Advanced Upgrade Distributed Safety V5.4 SP5 and STEP 7 Safety Advanced V11 for parallel use; incl. software on CD; Combo License for 1 user Distributed Safety V5.4 SP5 and STEP 7 Safety Advanced V11 for parallel use; includes software on CD; combo license for 1 user, license key download without software or documentation ¹⁾ ; email address required for delivery	6ES7 833-1FA11-0YE5 6ES7 833-1FA11-0YK5	Label cover For fail-safe modules (spare part), 10 units
DIN rail for active bus modules For max. 5 active bus modules for hot swapping function • 483 mm long • 530 mm long • 620 mm long • 2000 mm long	6ES7 195-1GA00-0XA0 6ES7 195-1GF30-0XA0 6ES7 195-1GG30-0XA0 6ES7 195-1GC00-0XA0	LK 393 cable guide For F modules; L+ and M connections, 5 units
Active bus module BM 2x40 Bus module for accepting 2 IO modules each 40 mm wide	6ES7 195-7HB00-0XA0	S7-300 manual Design, CPU data, module data, instruction list German 6ES7 398-8FA10-8AA0 English 6ES7 398-8FA10-8BA0
		SIMATIC Manual Collection Electronic manuals on DVD, multilingual: LOGO!, SIMADYN, SIMATIC bus components, SIMATIC C7, SIMATIC distributed I/O, SIMATIC HMI, SIMATIC Sensors, SIMATIC NET, SIMATIC PC Based Automation, SIMATIC PCS 7, SIMATIC PG/PC, SIMATIC S7, SIMATIC Software, SIMATIC TDC
		SIMATIC Manual Collection update service for 1 year Current "Manual Collection" DVD and the three subsequent updates

¹⁾ For up-to-date information and download availability, see:
www.siemens.com/tia-online-software-delivery

SIMATIC S7-300

F digital / analog modules

Isolation module

Overview



- Supports mixed operation of fail-safe signal modules in safety mode and S7-300 standard modules in an ET 200M when Cat. 4 or SIL 3 has to be achieved.
- The isolation module is not required if the safety class or safety category to be achieved is less than SIL 3 or Cat. 4, respectively.

When Cat. 4/SIL 3 is required, the isolation module must be implemented in the following situations:

Application	Isolation module must be used
Central use after CPU 31xF-2 DP or CPU 31xF-2 PN/DP <ul style="list-style-type: none"> • Only fail-safe modules in the tier • Standard and fail-safe modules in the tier 	Yes, behind the CPU Yes, after the last standard module and before the first fail-safe module
Central use after CPU 31xF-2 DP or CPU 31xF-2 PN/DP in an expansion rack <ul style="list-style-type: none"> • Only fail-safe modules in the tier • Standard and fail-safe modules in the tier 	Yes, after the IM 36x Yes, after the last standard module and before the first fail-safe module
Distributed behind the IM 153-2 with copper connection <ul style="list-style-type: none"> • Only fail-safe modules in the station • Standard and fail-safe modules in the station 	Yes, after the IM 153-2 Yes, after the last standard module and before the first fail-safe module
Distributed behind the IM 153-2 with fiber-optic connection <ul style="list-style-type: none"> • Only fail-safe modules in the station • Standard and fail-safe modules in the station 	No Yes, after the last standard module and before the first fail-safe module

Technical specifications

	6ES7 195-7KF00-0XA0
Weight	
Weight, approx.	10 g

Ordering data

	Order No.
Isolation module	6ES7 195-7KF00-0XA0
for simultaneous operation of fail-safe and standard modules in an ET 200M	
Isolation bus module	6ES7 195-7HG00-0XA0
for accommodating the isolation module in an ET 200M	

SIMATIC S7-300

SIPLUS F digital / analog modules

SIPLUS SM 326 F digital input modules -
Safety Integrated

Overview



- Digital inputs for the fail-safe SIPLUS S7 systems
- For connecting:
 - Switches and 2-wire proximity switches
 - Sensors according to NAMUR and mechanical contacts, also for signals from hazardous areas
- With integral safety functions for fail-safe operation
- Can be used in fail-safe operation
 - Centrally: With S7-31xF-2 DP
 - Distributed in ET 200M: With SIMATIC IM 151-7 F-CPU, S7-31xF-2 DP, S7-416F-2 and S7-400F/FH
- In standard operation can be used in the same way as S7-300 modules

Note:

SIPLUS extreme products are based on Siemens Industry standard products. The contents listed here were taken from the respective standard products. SIPLUS extreme specific information was added.

SIPLUS SM 326 F digital input module			
Order No.	6AG1 326-1BK02-2AB0	6AG1 326-1BK02-2AY0	6AG1 326-1RF00-4AB0
Order number based on	6ES7 326-1BK02-0AB0	6ES7 326-1BK02-0AB0	6AG1 326-1RF00-0AB0
Ambient temperature range	- 25 ... +60 °C		0 ... +60 °C
Conformal coating	Coating of the printed circuit boards and the electronic components		
Technical data	The technical data of the standard product applies except for the ambient conditions.		
Compliant with the standards for electronic equipment used on rolling stock (EN 50155, temperature T1, category 1)	No	Yes	No

Ambient conditions

Relative humidity 100%, condensation/frost permissible. No commissioning if condensation present.

For technical documentation on SIPLUS, see:
www.siemens.com/siplus-extreme

Ordering data

Ordering data	Order No.
SIPLUS SM 326 F digital input (extended temperature range and medial exposure)	
24 inputs, 24 V DC	6AG1 326-1BK02-2AB0
24 inputs, 24 V DC (EN 50155 compliant)	6AG1 326-1BK02-2AY0
8 inputs, 24 V DC, NAMUR	6AG1 326-1RF00-4AB0
Accessories	See SIMATIC SM 326 F digital input, page 5/90

SIMATIC S7-300

SIPLUS F digital / analog modules

SIPLUS SM 326 F digital output modules - Safety Integrated

Overview



- Digital outputs for the fail-safe SIMATIC S7 systems
- For connection of solenoid valves, DC contactors and indicator lights
- With integral safety functions for fail-safe operation
- Can be used in fail-safe mode
 - Centrally: With S7-31xF-2 DP
 - Distributed in ET 200M: With SIMATIC IM 151-7 F-CPU, S7-31xF-2 DP, S7-416F-2 and S7-400F/FH

Note:

SIPLUS extreme products are based on Siemens Industry standard products. The contents listed here were taken from the respective standard products. SIPLUS extreme specific information was added.

SIPLUS SM 326 F digital output module

Order No.	6AG1 326-2BF10-2AB0	6AG1 326-2BF10-2AY0	6AG1 326-2BF41-2AB0	6AG1 326-2BF41-2AY0
Order No. based on	6ES7 326-2BF10-0AB0	6ES7 326-2BF10-0AB0	6ES7 326-2BF41-0AB0	6ES7 326-2BF41-0AB0
Ambient temperature range	-25 ... +60 °C, condensation permissible			
Conformal coating	Coating of the printed circuit boards and the electronic components			
Technical data	The technical data of the standard product applies except for the ambient conditions			
Conforms with standards for electronic equipment used on rolling stock (EN 50155, temperature T1, category 1).	No	Yes	No	Yes

Ambient conditions

Relative humidity 100%, condensation/frost permissible. No commissioning if condensation present.

For technical documentation on SIPLUS, see:

www.siemens.com/siplus-extreme

Ordering data

SIPLUS SM 326 F digital output module

(extended temperature range and medial exposure)

10 outputs, 24 V DC

10 outputs, 24 V DC
(according to EN 50155)

8 outputs, 24 V DC, 2 A

8 outputs, 24 V DC, 2 A
(according to EN 50155)

Order No.

6AG1 326-2BF10-2AB0

6AG1 326-2BF10-2AY0

6AG1 326-2BF41-2AB0

6AG1 326-2BF41-2AY0

Order No.

Accessories

Active bus modules

(extended temperature range and medial exposure)

BM 2 x 40 for accepting
2 IO modules each 40 mm wide

BM 1 x 80 for accepting
1 IO module 80 mm wide

6AG1 195-7HB00-7XA0

6AG1 195-7HC00-2XA0

Further accessories

See SIMATIC SM 326 F digital output module, page 5/93

SIMATIC S7-300

SIPLUS F digital / analog modules

SIPLUS SM 336 F analog input modules - Safety Integrated

Overview



- Analog inputs for fail-safe SIPLUS S7 systems
- Applicable in the ET 200M distributed I/O device with IM 153-2 HF as well as centrally with SIPLUS S7-31xF-2 DP
- Properties of the SM 336; F-AI 6 x 0/4 ... 20 mA HART:
 - 6 analog inputs with galvanic isolation between channels and backplane bus
 - Input ranges: 0 mA to 20 mA, 4 mA to 20 mA
 - Short-circuit proof power supply of 2 or 4-wire transmitter via the module
 - External encoder supply possible
 - Applicable in safety mode
 - HART communication
 - Firmware update using HW Config
 - Identification data

Note:

SIPLUS extreme products are based on Siemens Industry standard products. The contents listed here were taken from the respective standard products. SIPLUS extreme specific information was added.

SIPLUS SM 336 F analog input module

Order number	6AG1 336-4GE00-4AB0
Order No. based on	6ES7 336-4GE00-0AB0
Ambient temperature range	0 ... +60 °C
Conformal coating	Coating of the printed circuit boards and the electronic components
Technical data	The technical data of the standard product applies except for the ambient conditions.

Ambient conditions

Relative humidity	100%, condensation/frost permissible. No commissioning if condensation present.
-------------------	---

For technical documentation on SIPLUS, see:
www.siemens.com/siplus-extreme

Ordering data

Order No.

SIPLUS SM 336 F analog input module	
(medial exposure)	
6 inputs, 15 bit, 0/4 - 20 mA HART	6AG1 336-4GE00-4AB0
Accessories	See SIMATIC SM 336 F analog input module, page 5/95

SIMATIC S7-300

Ex digital modules

Ex digital input modules

Overview



- Digital inputs for signals from the Ex field
- For the connection of intrinsically safe digital equipment from the Ex field
- 4 DI NAMUR
- 4 digital inputs in 4 channel modules (single-channel isolation)
- Connectable encoder in accordance with DIN EN 60947-5-6 and NAMUR, optionally with wired or unwired mechanical contacts
- Diagnostics and diagnostics alarm programmable

Technical specifications

6ES7 321-7RD00-0AB0	
Supply voltage	
Load voltage L+	
• Rated value (DC)	24 V
Input current	
from load voltage L+ (without load), max.	50 mA
from backplane bus 5 V DC, max.	80 mA
Encoder supply	
Output voltage	via the inputs
Power losses	
Power loss, typ.	1.1 W
Digital inputs	
Number of NAMUR inputs	4
Input voltage	
• Rated value, DC	8.2 V; from internal power circuit supply
Input current	
• on wire break, max.	0.1 mA
• on short -circuit, max.	8.5 mA
• for NAMUR encoders	
- for signal "0"	0.35 to 1.2 mA
- for signal "1"	2.1 to 7 mA
Input delay (for rated value of input voltage)	
• Input frequency (with a time delay of 0.1 ms), max.	2 kHz
• for NAMUR inputs	
- Parameterizable	Yes; 0.1 / 0.5 / 3 / 15 / 20 ms (plus 0.25 ms preparation time)
Cable length	
• Cable length unshielded, max.	200 m

6ES7 321-7RD00-0AB0	
Encoder	
Connectable encoders	
• NAMUR encoder	Yes; Two-wire connection
Interrupts/diagnostics/status information	
Diagnostic messages	
• Diagnostic information readable	Yes
Ex(i) characteristics	
Max. values of input circuits (per channel)	
• Co (permissible external capacity), max.	3 µF
• Io (short-circuit current), max.	14.1 mA
• Lo (permissible external inductivity), max.	100 mH
• Po (power of load), max.	33.7 mW
• Uo (output no-load voltage), max.	10 V
Galvanic isolation	
Galvanic isolation digital inputs	
• Galvanic isolation digital inputs	Yes
• between the channels, in groups of	1
Standards, approvals, certificates	
Use in hazardous areas	
• Type of protection acc. to EN 50020 (CENELEC)	[EEx ib] IIC
• Type of protection acc. to FM	Class II, Division 2, Group A, B, C, D T4 Ex-96.D.2094X
• Test number PTB	
Connection method	
required front connector	20-pin
Weight	
Weight, approx.	230 g

SIMATIC S7-300

Ex digital modules

Ex digital input modules

Ordering data	Order No.	Ordering data	Order No.
Ex digital input module 4 inputs, isolated, NAMUR	6ES7 321-7RD00-0AB0	Labeling sheets for machine inscription for modules with 20-pin front connector, DIN A4, for printing with laser printer; 10 units	
Front connector 20-pin, with screw contacts • 1 unit • 100 units	6ES7 392-1AJ00-0AA0 6ES7 392-1AJ00-1AB0	petrol	6ES7 392-2AX00-0AA0
Front door, elevated design e.g. for 32 channel modules; enables connection of 1.3 mm ² /16 AWG wires	6ES7 328-0AA00-7AA0	light-beige	6ES7 392-2BX00-0AA0
LK 393 cable guide Mandatory for operation in Ex-hazard areas	6ES7 393-4AA00-0AA0	yellow	6ES7 392-2CX00-0AA0
Labeling strips 10 units (spare part), for modules with 20-pin front connector	6ES7 392-2XX00-0AA0	red	6ES7 392-2DX00-0AA0
Label cover 10 units (spare part), for modules with 20-pin front connector	6ES7 392-2XY00-0AA0	SIMATIC Manual Collection Electronic manuals on DVD, multilingual: LOGO!, SIMADYN, SIMATIC bus components, SIMATIC C7, SIMATIC distributed I/O, SIMATIC HMI, SIMATIC Sensors, SIMATIC NET, SIMATIC PC Based Automation, SIMATIC PCS 7, SIMATIC PG/PC, SIMATIC S7, SIMATIC Software, SIMATIC TDC	6ES7 998-8XC01-8YE0
		SIMATIC Manual Collection update service for 1 year Current "Manual Collection" DVD and the three subsequent updates	6ES7 998-8XC01-8YE2

SIMATIC S7-300

Ex digital modules

Ex digital output modules

Overview



- Digital outputs for signals from the Ex field
- For the connection of intrinsically safe digital equipment from the Ex field
- 4 DO DC 24 V/10mA or 4 DO DC 15 V/20 mA
- 4 digital outputs in 4 channel modules (single-channel isolation)
- Diagnostics and diagnostics alarm programmable
- Substitute value behavior programmable

5

Technical specifications

	6ES7 322-5SD00-0AB0	6ES7 322-5RD00-0AB0
Supply voltage		
Load voltage L+		
• Rated value (DC)	24 V	24 V
Input current		
from load voltage L+ (without load), max.	160 mA	160 mA
from backplane bus 5 V DC, max.	70 mA	70 mA
Power losses		
Power loss, typ.	3 W	3 W
Digital outputs		
Number/binary outputs	4	4
Functionality/short-circuit strength	Yes; Electronic	Yes; Electronic
• Response threshold, typ.	Output current with short-circuit protection, min. 10 mA + 10 %	Output current with short-circuit protection, min. 20.5 mA + 10 %
Load resistance range		
• upper limit	390 Ω; Two-wire connection	200 Ω; Two-wire connection
Output voltage		
• Rated value (DC)	24 V	15 V
Output current		
• for signal "1" permissible range for 0 to 60 °C, max.	10 mA; +/-10 %	20 mA; +/-10 %
Switching frequency		
• with resistive load, max.	100 Hz	100 Hz
Cable length		
• Cable length unshielded, max.	200 m	200 m
Interrupts/diagnostics/status information		
Diagnostic messages		
• Diagnostic information readable	Yes	Yes
• Short circuit	Yes	Yes
• Group error	Yes	Yes
Ex(i) characteristics		
Max. values of output circuits (per channel)		
• Co (permissible external capacity), max.	90 nF	500 nF
• Io (short-circuit current), max.	70 mA	85 mA
• Lo (permissible external inductivity), max.	6.7 mH	5 mH
• Po (power of load), max.	440 mW	335 mW
• Uo (output no-load voltage), max.	25.2 V	15.75 V

Technical specifications (continued)

	6ES7 322-5SD00-0AB0	6ES7 322-5RD00-0AB0
Galvanic isolation		
Galvanic isolation digital outputs		
• Galvanic isolation digital outputs	Yes	Yes
• between the channels, in groups of	1	1
Standards, approvals, certificates		
Use in hazardous areas		
• Type of protection acc. to EN 50020 (CENELEC)	[EEx ib] IIC	[EEx ib] IIC
• Type of protection acc. to FM	Class I, Division 2, Group A, B, C, D T4	AIS CL.1, DIV 1, GP A, B, C, D; CL.I, DIV 2, GP A, B, C, D T4
• Test number PTB	Ex-96.D.2093X	Ex-96.D.2102X
Connection method		
required front connector	20-pin	20-pin
Weight		
Weight, approx.	230 g	230 g

Ordering data

	Order No.		Order No.
Ex digital output modules		Labeling sheets for machine inscription	
4 outputs, isolated, 24 V DC, 10 mA	6ES7 322-5SD00-0AB0	for modules with 20-pin front connector, DIN A4, for printing with laser printer; 10 units	
4 outputs, isolated, 15 V DC, 20 mA	6ES7 322-5RD00-0AB0	petrol	6ES7 392-2AX00-0AA0
Front connector		light-beige	6ES7 392-2BX00-0AA0
20-pin, with screw contacts		yellow	6ES7 392-2CX00-0AA0
• 1 unit	6ES7 392-1AJ00-0AA0	red	6ES7 392-2DX00-0AA0
• 100 units	6ES7 392-1AJ00-1AB0	SIMATIC Manual Collection	6ES7 998-8XC01-8YE0
Front door, elevated design		Electronic manuals on DVD, multilingual: LOGO!, SIMADYN, SIMATIC bus components, SIMATIC C7, SIMATIC distributed I/O, SIMATIC HMI, SIMATIC Sensors, SIMATIC NET, SIMATIC PC Based Automation, SIMATIC PCS 7, SIMATIC PG/PC, SIMATIC S7, SIMATIC Software, SIMATIC TDC	
e.g. for 32 channel modules; enables connection of 1.3 mm ² /16 AWG wires	6ES7 328-0AA00-7AA0	SIMATIC Manual Collection update service for 1 year	6ES7 998-8XC01-8YE2
LK 393 cable guide	6ES7 393-4AA00-0AA0	Current "Manual Collection" DVD and the three subsequent updates	
Mandatory for operation in Ex-hazard areas			
Labeling strips	6ES7 392-2XX00-0AA0		
10 units (spare part), for modules with 20-pin front connector			
Label cover	6ES7 392-2XY00-0AA0		
10 units (spare part), for modules with 20-pin front connector			

SIMATIC S7-300

Ex analog modules

Ex analog input modules

Overview



- Analog inputs for signals from the Ex field
- For the connection of intrinsically safe analog equipment from the Ex field
- 8 or 4 analog inputs in 4 channel groups (single-channel isolation)
- Measurement type and range can be selected for each channel
- Diagnostics and diagnostics alarm programmable
- Programmable threshold alarm
- HART-compatible inputs (only 6ES7331-7RD00-0AB0)

5

Technical specifications

	6ES7 331-7RD00-0AB0	6ES7 331-7SF00-0AB0
Supply voltage		
Load voltage L+		
• Rated value (DC)	24 V	24 V
Input current		
from backplane bus 5 V DC, max.	60 mA	120 mA
from supply voltage L+, max.	150 mA	
Output voltage		
Power supply to the transmitters		
• present	Yes	
• Rated value (DC)	13 V; at 22 mA	
• No-load voltage (DC)	25.2 V	
Power losses		
Power loss, typ.	3 W	0.6 W
Analog inputs		
Number of analog inputs	4	8; 8x thermocouples; 4x RTD thermoresistors
permissible input current for current input (destruction limit), max.	40 mA	
Input ranges (rated values), currents		
• 0 to 20 mA	Yes	
• 4 to 20 mA	Yes	
Input ranges (rated values), thermoelements		
• Type B		Yes
• Type E		Yes
• Type J		Yes
• Type K		Yes
• Type L		Yes
• Type N		Yes
• Type R		Yes
• Type S		Yes
• Type T		Yes
• Type U		Yes
Input ranges (rated values), resistance thermometers		
• Ni 100		Yes
• Pt 100		Yes
• Pt 200		Yes
Cable length		
• Cable length, shielded, max.	200 m	200 m; TC: 50m

Technical specifications (continued)

	6ES7 331-7RD00-0AB0	6ES7 331-7SF00-0AB0
Analog value creation		
Measurement principle	Sigma Delta	Sigma Delta
Integrations and conversion time/ resolution per channel		
• Resolution with overrange (bit including sign), max.	16 bit; 10 to 15 bits + sign	16 bit; 10 to 15 bits + sign
• Integration time, parameterizable	Yes; 2.5 to 100 ms	Yes; 2.5 to 100 ms
• Interference voltage suppression for interference frequency f1 in Hz	10 to 400 Hz	10 to 400 Hz
Encoder		
Connection of signal encoders		
• for current measurement as 2-wire transducer	Yes	Yes
• for current measurement as 4-wire transducer	Yes	Yes
Errors/accuracies		
Temperature error (relative to input area)		Temperature error: 0.001 to 0.002 %/K
Operational limit in overall temperature range		
• Current, relative to input area	+/- 0,45 %	
• Resistance-type thermometer, relative to input area		0.09 to 0.04%
Basic error limit (operational limit at 25 °C)		
• Current, relative to input area	+/- 0,1 %	
• Resistance-type thermometer, relative to input area		+/- 0,1 %
Interference voltage suppression for $f = n \times (f1 \pm 1\%)$, f1 = interference frequency		
• Series mode interference (peak value of interference < rated value of input range), min.	60 dB	60 dB
• Common mode interference, min.	130 dB	130 dB
Interrupts/diagnostics/status information		
Diagnostic messages		
• Diagnostic information readable	Yes	Yes
• Overrange	Yes	Yes
• Wire break in signal transmitter cable	Yes	Yes
• Short circuit of the signal encoder cable	Yes	Yes
Ex(i) characteristics		
Max. values of input circuits (per channel)		
• Co (permissible external capacity), max.	90 nF	43 µF
• Io (short-circuit current), max.	68.5 mA	28.8 mA
• Lo (permissible external inductivity), max.	7.5 mH	40 mH
• Po (power of load), max.	431 mW	41.4 mW
• Ri, max.	50 Ω	
• Uo (output no-load voltage), max.	25.2 V	5.9 V
Galvanic isolation		
Galvanic isolation analog inputs		
• Galvanic isolation analog inputs	Yes	Yes
Permissible potential difference		
between the inputs (UCM)	60 V DC/30 V AC when used in the hazardous area; 400 V DC/250 V AC when used in NON-hazardous area	60 V DC/30 V AC when used in the hazardous area; 400 V DC/250 V AC when used in NON-hazardous area
between inputs and MANA (UCM)	60 V DC/30 V AC when used in the hazardous area; 400 V DC/250 V AC when used in NON-hazardous area	60 V DC/30 V AC when used in the hazardous area; 400 V DC/250 V AC when used in NON-hazardous area

SIMATIC S7-300

Ex analog modules

Ex analog input modules

Technical specifications (continued)

	6ES7 331-7RD00-0AB0	6ES7 331-7SF00-0AB0
Standards, approvals, certificates		
Use in hazardous areas		
• Type of protection acc. to EN 50020 (CENELEC)	[EEx ib] IIC	[EEx ib] IIC
• Type of protection acc. to FM	Class I, Division 2, Group A, B, C, D T4	Class I, Division 2, Group A, B, C, D T4
• Test number PTB	Ex-96.D.2092X	Ex-96.D.2108X
Connection method		
required front connector	20-pin	20-pin
Weight		
Weight, approx.	290 g	210 g

Ordering data

	Order No.		Order No.
Ex analog input modules		Labeling sheets for machine inscription	
4 inputs, isolated, 0/4 to 20 mA, 15 bit	6ES7 331-7RD00-0AB0	for modules with 20-pin front connector, DIN A4, for printing with laser printer; 10 units	
8/4 inputs, isolated, for thermocouples and Pt100, Pt200, Ni100	6ES7 331-7SF00-0AB0	petrol	6ES7 392-2AX00-0AA0
Front connector		light-beige	6ES7 392-2BX00-0AA0
20-pin, with screw contacts		yellow	6ES7 392-2CX00-0AA0
• 1 unit	6ES7 392-1AJ00-0AA0	red	6ES7 392-2DX00-0AA0
• 100 units	6ES7 392-1AJ00-1AB0	SIMATIC Manual Collection	6ES7 998-8XC01-8YE0
Front door, elevated design		Electronic manuals on DVD, multilingual: LOGO!, SIMADYN, SIMATIC bus components, SIMATIC C7, SIMATIC distributed I/O, SIMATIC HMI, SIMATIC Sensors, SIMATIC NET, SIMATIC PC Based Automation, SIMATIC PCS 7, SIMATIC PG/PC, SIMATIC S7, SIMATIC Software, SIMATIC TDC	
e.g. for 32 channel modules; enables connection of 1.3 mm ² /16 AWG wires	6ES7 328-0AA00-7AA0	SIMATIC Manual Collection update service for 1 year	6ES7 998-8XC01-8YE2
LK 393 cable guide	6ES7 393-4AA00-0AA0	Current "Manual Collection" DVD and the three subsequent updates	
Mandatory for operation in Ex-hazard areas			
Labeling strips	6ES7 392-2XX00-0AA0		
10 units (spare part), for modules with 20-pin front connector			
Label cover	6ES7 392-2XY00-0AA0		
10 units (spare part), for modules with 20-pin front connector			

5

Overview



- Analog outputs for signals from the Ex field
- For the connection of intrinsically safe analog equipment from the Ex field
- 4 analog outputs in 4 channel modules (single-channel isolation)
- Diagnostics and diagnostics alarm programmable

5

Technical specifications

6ES7 332-5RD00-0AB0	
Supply voltage	
Load voltage L+	
• Rated value (DC)	24 V
Input current	
from load voltage L+ (without load), max.	180 mA
from backplane bus 5 V DC, max.	80 mA
Power losses	
Power loss, typ.	4 W
Analog outputs	
Number of analog outputs	4
Voltage output, short-circuit protection	Yes
Voltage output, short-circuit current, max.	70 mA
Current output, no-load voltage, max.	14 V
Output ranges, current	
• 0 to 20 mA	Yes
• 4 to 20 mA	Yes
Connection of actuators	
• for current output 2-conductor connection	Yes
Load impedance (in rated range of output)	
• with current outputs, max.	500 Ω
Cable length	
• Cable length, shielded, max.	200 m
Analog value creation	
Integrations and conversion time/ resolution per channel	
• Resolution with overrange (bit including sign), max.	15 bit
• Basic conversion time, ms	2.5 ms
Errors/accuracies	
Operational limit in overall temperature range	
• Current, relative to output area	+/- 0,55 %
Basic error limit (operational limit at 25 °C)	
• Current, relative to output area	+/- 0,2 %

6ES7 332-5RD00-0AB0	
Interrupts/diagnostics/status information	
Diagnostic messages	
• Diagnostic information readable	Yes
• Overrange	Yes
• Wire break in actuator cable	Yes
• Group error	Yes
Ex(i) characteristics	
Max. values of output circuits (per channel)	
• Co (permissible external capacity), max.	850 nF
• Io (short-circuit current), max.	70 mA
• Lo (permissible external inductivity), max.	6.6 mH
• Po (power of load), max.	440 mW
• Uo (output no-load voltage), max.	14 V
Galvanic isolation	
Galvanic isolation analog outputs	
• Galvanic isolation analog outputs	Yes
Permissible potential difference	
between outputs and MANA (UCM)	60 V DC/30 V AC when used in the hazardous area; 400 V DC/250 V AC when used in NON-hazardous area
between the outputs (UCM)	60 V DC/30 V AC when used in the hazardous area; 400 V DC/250 V AC when used in NON-hazardous area
Standards, approvals, certificates	
Use in hazardous areas	
• Type of protection acc. to EN 50020 (CENELEC)	[EEx ib] IIC
• Type of protection acc. to FM	Class I, Division 2, Group A, B, C, D T4
• Test number PTB	Ex-96.D.2026X
Connection method	
required front connector	20-pin
Weight	
Weight, approx.	280 g

SIMATIC S7-300

Ex analog modules

Ex analog output modules

Ordering data

Order No.

Ex analog output module

4 outputs, isolated, 0/4 to 20 mA

6ES7 332-5RD00-0AB0**Front connector**

20-pin, with screw contacts

- 1 unit
- 100 units

6ES7 392-1AJ00-0AA0
6ES7 392-1AJ00-1AB0
Front door, elevated designe.g. for 32 channel modules;
enables connection of
1.3 mm²/16 AWG wires**6ES7 328-0AA00-7AA0****LK 393 cable guide**Mandatory for operation in
Ex-hazard areas**6ES7 393-4AA00-0AA0****Labeling strips**10 units (spare part), for modules
with 20-pin front connector**6ES7 392-2XX00-0AA0****Label cover**10 units (spare part), for modules
with 20-pin front connector**6ES7 392-2XY00-0AA0**

Order No.

Labeling sheets for machine inscriptionfor modules with 20-pin front
connector, DIN A4, for printing with
laser printer; 10 units

petrol

6ES7 392-2AX00-0AA0

light-beige

6ES7 392-2BX00-0AA0

yellow

6ES7 392-2CX00-0AA0

red

6ES7 392-2DX00-0AA0**SIMATIC Manual Collection**Electronic manuals on DVD,
multilingual: LOGO!, SIMADYN,
SIMATIC bus components,
SIMATIC C7,
SIMATIC distributed I/O,
SIMATIC HMI, SIMATIC Sensors,
SIMATIC NET, SIMATIC PC Based
Automation, SIMATIC PCS 7,
SIMATIC PG/PC, SIMATIC S7,
SIMATIC Software, SIMATIC TDC**6ES7 998-8XC01-8YE0****SIMATIC Manual Collection
update service for 1 year**Current "Manual Collection" DVD
and the three subsequent updates**6ES7 998-8XC01-8YE2**

Overview



- One-channel intelligent counter module for simple counting tasks
- For direct connection of incremental encoders
- Comparison function with 2 specifiable comparison values
- Integrated digital outputs to output the response upon reaching the comparison value.
- Operating modes:
 - Continuous counting
 - One-shot counting
 - Periodic counting
- Special functions:
 - Set counter
 - Latch counter
- Start/stop counter with gate function

Note:

Incremental encoders and pre-assembled connecting cables for counting and positioning functions are offered under SIMODRIVE Sensor or Motion Connect 500.

www.siemens.com/simatic-technology

Technical specifications

6ES7 350-1AH03-0AE0	
Supply voltage	
Aux. voltage 1L+, load voltage 2 L+	
• Rated value (DC)	24 V
• Permissible range (ripple included)	
- dynamic, lower limit (DC)	18.5 V
- dynamic, upper limit (DC)	30.2 V
- static, lower limit (DC)	20.4 V
- static, upper limit (DC)	28.8 V
• non-periodic skip	
- Duration	500 ms
- Recovery time	50 s
- Value	35 V
Input current	
from load voltage 1L+ (without load), max.	40 mA
from backplane bus 5 V DC, max.	160 mA
Encoder supply	
5 V encoder supply	
• 5 V	Yes; 5.2 V +/-2%
• Output current, max.	300 mA
24 V encoder supply	
• 24 V	Yes; 1L+ (-3 V)
• Output current, max.	400 mA
Power losses	
Power loss, typ.	4.5 W
Digital inputs	
Number/binary inputs	3
Functions	1 for gate start, 1 for gate stop, 1 for setting the counter
Input voltage	
• for signal "0"	-28.8 to +5 V
• for signal "1"	+11 to +28.8 V
Input current	
• for signal "1", typ.	9 mA

6ES7 350-1AH03-0AE0	
Digital outputs	
Number/binary outputs	2
Functionality/short-circuit strength	Yes; Clocked electronically
Limitation of inductive shutdown voltage to	2L+ (-39 V)
Output voltage	
• for signal "0", max.	3 V
• for signal "1", min.	2L+ (-1.5 V)
Output current	
• for signal "1" rated value	0.5 A
• for signal "1" permissible range for 0 to 60 °C, min.	5 mA
• for signal "1" permissible range for 0 to 60 °C, max.	0.6 A
Output delay with resistive load	
• "0" to "1", max.	300 µs
Encoder	
Connectable encoders	
• Incremental encoder (symmetrical)	Yes; With 2 pulse trains offset by 90°
• Incremental encoder (asymmetrical)	Yes
• 24 V initiator	Yes
• 24 V directional element	Yes; 1 pulse train, 1 direction level
Counter	
Number of counter inputs	1
Counting range, description	32 bit or +/-31 bit
Minimum pulse width, adjustable	Yes; 2.5 or 25 µs
Counter input 5 V	
• Type	RS 422
• Terminating resistor	220 Ω
• Differential input voltage	1.3 V
• Counting frequency, max.	500 kHz
Counter input 24 V	
• Input voltage, for signal "0"	-28.8 to +5 V
• Input voltage, for signal "1"	+11 to +28.8 V
• Input current, for signal "1", typ.	9 mA
• Counting frequency, max.	200 kHz
• Minimum pulse width	2.5 µs

SIMATIC S7-300

Function modules

FM 350-1 counter modules

Technical specifications (continued)

6ES7 350-1AH03-0AE0	
Galvanic isolation	
Galvanic isolation digital inputs	
• between the channels and the backplane bus	Yes; Optocoupler
Galvanic isolation digital outputs	
• between the channels and the backplane bus	Yes; Optocoupler
Galvanic isolation counter	
• between the channels and the backplane bus	Yes; Optocoupler
Permissible potential difference between different circuits	75 VDC / 60 VAC

6ES7 350-1AH03-0AE0	
Isolation	
Isolation checked with	500 V
Connection method	
required front connector	1x 20-pin
Dimensions	
Width	40 mm
Height	125 mm
Depth	120 mm
Weight	
Weight, approx.	250 g

5

Ordering data

Ordering data	Order No.
FM 350-1 counter module with 1 channel, max. 500 kHz; for incremental encoder	6ES7 350-1AH03-0AE0
Coding plug - Range card for analog inputs Spare part	6ES7 974-0AA00-0AA0
Front connector	
20-pin, with screw contacts	
• 1 unit	6ES7 392-1AJ00-0AA0
• 100 units	6ES7 392-1AJ00-1AB0
20-pin, with spring-loaded contacts	
• 1 unit	6ES7 392-1BJ00-0AA0
• 100 units	6ES7 392-1BJ00-1AB0
Bus connectors	6ES7 390-0AA00-0AA0
1 unit (spare part)	
Labeling strips	6ES7 392-2XX00-0AA0
10 units (spare part)	
Labeling sheets for machine inscription	See under "Accessories", page 5/248
Slot number label	6ES7 912-0AA00-0AA0
Spare part	
Shield connection element	6ES7 390-5AA00-0AA0
80 mm wide, with 2 rows for 4 terminals each	
Terminal elements	
2 units	
For 2 cables with 2 mm to 6 mm diameter	6ES7 390-5AB00-0AA0
For 1 cable with 3 mm to 8 mm diameter	6ES7 390-5BA00-0AA0
For 1 cable with 4 mm to 13 mm diameter	6ES7 390-5CA00-0AA0

Order No.

Connectable incremental encoders 6FX2 001-2...

Refer to the Industry Mall under SIMODRIVE Sensor or Motion Connect 500 (see also www.siemens.com/simatic-technology)

Signal cable

Pre-assembled for HTL and TTL encoder, without sub D connector, UL/DESINA

Length code:

0 m
100 m
200 m
0 m
10 m
20 m
30 m
40 m
50 m
60 m
70 m
80 m
90 m

6FX5 002-2CA12-

0

1
2
3

A
B
C
D
E
F
G
H
J
K

A
B
C
D
E
F
G
H
J
K

Overview



- 8-channel intelligent counter module for universal counting and measuring
- To directly connect 24 V incremental encoders, direction sensors, initiators or NAMUR encoders.
- Check function with preselectable set points (number depends on mode)
- Integrated digital outputs to output the response when the setpoint is reached
- Modes:
 - Continuous/one-off/periodic counting
 - Frequency/speed measurement
 - Cycle duration measurement
 - Dosing

Note:

Incremental encoder and prefabricated connecting cables for counter and positioning function are offered under SIMODRIVE Sensor and Motion Connect 500.

www.siemens.com/simatic-technology

Technical specifications

6ES7 350-2AH01-0AE0	
Supply voltage	
Aux. voltage 1L+, load voltage 2 L+	
• Rated value (DC)	24 V
• permissible range, lower limit (DC)	20.4 V
• permissible range, upper limit (DC)	28.8 V
Input current	
from load voltage L+ (without load), max.	150 mA
from backplane bus 5 V DC, max.	100 mA
Encoder supply	
Output voltage	NAMUR-encoder supply: 8.2 V +/-2%
Output current, rated value	200 mA
Output current	
• Short-circuit protection	Yes
Power losses	
Power loss, typ.	10 W
Digital inputs	
Number/binary inputs	8
Functions	1 each for gate start/ gate stop
Input voltage	
• for signal "0"	-3 to +5 V
• for signal "1"	11 to 30.2 V
Input current	
• for signal "0", max. (permissible quiescent current)	2 mA
• for signal "1", typ.	9 mA
Input delay (for rated value of input voltage)	
• for standard inputs - at "0" to "1", max.	50 µs
Cable length	
• Cable length, shielded, max.	100 m

6ES7 350-2AH01-0AE0	
Digital outputs	
Number/binary outputs	8
Functionality/short-circuit strength	Yes
Limitation of inductive shutdown voltage to	L+ (-40 V)
Output voltage	
• for signal "1", min.	L+ (-0.8 V)
Output current	
• for signal "1" rated value	0.5 A
• for signal "0" residual current, max.	0.5 mA
Output delay with resistive load	
• "0" to "1", max.	300 µs
Switching frequency	
• with resistive load, max.	500 Hz
• with inductive load, max.	0.5 Hz
Aggregate current of outputs (per group)	
• horizontal installation	
- up to 40 °C, max.	4 A
- up to 60 °C, max.	2 A
• all other mounting positions	
- up to 40 °C, max.	2 A
Cable length	
• Cable length, shielded, max.	600 m
• Cable length unshielded, max.	100 m
Encoder	
Connectable encoders	
• Incremental encoder (asymmetrical)	Yes
• 24 V initiator	Yes
• 24 V directional element	Yes
• NAMUR encoder	Yes
• 2-wire sensor	Yes
NAMUR encoder	
• Number of NAMUR inputs	8
• Input signal	to DIN 19 234
• Input current, for signal "0", max.	1.2 mA
• Input current, for signal "1", min.	2.1 mA
• Input delay, max.	50 µs
• Input frequency, max.	20 kHz
• Cable length, shielded, max.	100 m

SIMATIC S7-300

Function modules

FM 350-2 counter modules

Technical specifications (continued)

6ES7 350-2AH01-0AE0	
Interrupts/diagnostics/status information	
Alarms	
• Diagnostic alarm	Yes; Parameterizable
• Hardware interrupt	Yes; Parameterizable
Diagnostic messages	
• Diagnostic functions	Yes; Diagnostic information readable
Counter	
Counter input 24 V	
• Number	8; 32 bit or +/-31 bit
• Input voltage, for signal "0"	-3 to +5 V
• Input voltage, for signal "1"	11 to 30.2 V
• Input current, for signal "0", max. (permissible quiescent current)	2 mA
• Input current, for signal "1", typ.	9 mA
• Input delay, max.	50 µs
• Counting frequency, max.	20 kHz; Incremental encoder: 10 kHz
• Cable length, max.	100 m

6ES7 350-2AH01-0AE0	
Galvanic isolation	
Galvanic isolation digital inputs	
• between the channels and the backplane bus	Yes; and shielding
• between the channels and the backplane bus (NAMUR)	yes, against backplane bus and shielding
Galvanic isolation digital outputs	
• between the channels and the backplane bus	Yes; and shielding
Galvanic isolation counter	
• between the channels and the backplane bus	Yes; and shielding
Connection method	
required front connector	1x 40-pin
Dimensions	
Width	80 mm
Height	125 mm
Depth	120 mm
Weight	
Weight, approx.	460 g

Ordering data

Ordering data	Order No.
FM 350-2 counter module	6ES7 350-2AH01-0AE0
With 8 channels, max. 20 kHz; for 24 V incremental encoders and NAMUR encoders; incl. configuration package and electronic documentation on CD	
Front connector	
40-pin, with screw contacts	
• 1 unit	6ES7 392-1AM00-0AA0
• 100 units	6ES7 392-1AM00-1AB0
40-pin, with spring-loaded contacts	
• 1 unit	6ES7 392-1BM01-0AA0
• 100 units	6ES7 392-1BM01-1AB0
Bus connectors	6ES7 390-0AA00-0AA0
1 unit (spare part)	
Labeling strips	6ES7 392-2XX10-0AA0
10 units (spare part)	
Labeling sheets for machine inscription	See under "Accessories", page 5/248
Slot number label	6ES7 912-0AA00-0AA0
Spare part	
Shield connection element	6ES7 390-5AA00-0AA0
80 mm wide, with 2 rows for 4 terminals each	
Terminal elements	
2 units	
For 2 cables with 2 mm to 6 mm diameter	6ES7 390-5AB00-0AA0
For 1 cable with 3 mm to 8 mm diameter	6ES7 390-5BA00-0AA0
For 1 cable with 4 mm to 13 mm diameter	6ES7 390-5CA00-0AA0

Ordering data	Order No.
Signal cable	
Pre-assembled for HTL and TTL encoder, without sub D connector, UL/DESINA	6FX5 002-2CA12- 0
Length code:	
0 m	1
100 m	2
200 m	3
0 m	A
10 m	B
20 m	C
30 m	D
40 m	E
50 m	F
60 m	G
70 m	H
80 m	J
90 m	K
0 m	A
1 m	B
2 m	C
3 m	D
4 m	E
5 m	F
6 m	G
7 m	H
8 m	J
9 m	K

Overview



- Two-channel positioning module for rapid-traverse/creep-speed drives
- 4 digital outputs per channel for motor control
- Incremental or synchro-serial position decoding

Note:

SIMODRIVE Sensor/Motion Connect 500 feature position-measuring systems and preassembled connecting cables for counting and positioning functions.

www.siemens.com/simatic-technology

Technical specifications

6ES7 351-1AH02-0AE0	
Supply voltage	
24 V DC	Yes
permissible range, lower limit (DC)	20.4 V
permissible range, upper limit (DC)	28.8 V
Load voltage L+	
• Rated value (DC)	24 V
• permissible range, lower limit (DC)	20.4 V
• permissible range, upper limit (DC)	28.8 V
Input current	
Current consumption, max.	350 mA
from backplane bus 5 V DC, max.	150 mA; max.
Encoder supply	
5 V encoder supply	
• 5 V	Yes
• Output current, max.	350 mA
• Cable length, max.	32 m
24 V encoder supply	
• 24 V	Yes
• Output current, max.	400 mA; Per channel
• Cable length, max.	100 m
Digital inputs	
Number/binary inputs	8
Functions	Reference cams, reversing cams, flying actual value setting, start/stop positioning
Input voltage	
• Rated value, DC	24 V
• for signal "0"	-3 to +5 V
• for signal "1"	11 to 30 V
Input current	
• for 2-wire sensor	
- for signal "0", typ.	2 mA
- for signal "1", typ.	6 mA

6ES7 351-1AH02-0AE0	
Digital outputs	
Number/binary outputs	8
Functions	Rapid traverse, creep, run right, run left
Functionality/short-circuit strength	Yes
Output voltage	
• Rated value (DC)	24 V
• for signal "1", min.	UP - 0.8 V
Output current	
• for signal "1" permissible range for 0 to 60 °C, min.	5 mA; with UPmax
• for signal "1" permissible range for 0 to 60 °C, max.	600 mA; with UPmax
• for signal "0" residual current, max.	0.5 mA
Encoder	
Connectable encoders	
• Incremental encoder (symmetrical)	Yes
• Incremental encoder (asymmetrical)	Yes
• Absolute encoder (SSI)	Yes
• 2-wire sensor	Yes
- Permissible quiescent current (2-wire sensor), max.	2 mA; on signal "0", max. 2 mA; on signal "1", max. 6 mA
Encoder signals, incremental encoder (symmetrical)	
• Trace mark signals	A, notA, B, notB
• Zero mark signal	N, notN
• Input signal	5 V difference signal (phys. RS 422)
• Input frequency, max.	0.5 MHz
Encoder signals, incremental encoder (asymmetrical)	
• Trace mark signals	A, B
• Zero mark signal	N
• Input voltage	24 V
• Input frequency, max.	50 kHz; 50 kHz for 25 m cable length; 25 kHz for 100 m cable length
Encoder signals, absolute encoder (SSI)	
• Input signal	5 V difference signal (phys. RS 422)
• Data signal	DATA, notDATA
• Clock signal	CL, notCL
• Message frame length, parameterizable	13 or 25 bit
• Clock frequency, max.	1.5 MHz
• Gray code	Yes
• Cable length, shielded, max.	200 m; At max. 188 kHz

SIMATIC S7-300

Function modules

FM 351 positioning modules

Technical specifications (continued)

6ES7 351-1AH02-0AE0	
Galvanic isolation	
Galvanic isolation digital inputs	
• Galvanic isolation digital inputs	Yes
Galvanic isolation digital outputs	
• Galvanic isolation digital outputs	Yes
Connection method	
required front connector	1x 20-pin

6ES7 351-1AH02-0AE0	
Dimensions	
Width	80 mm
Height	125 mm
Depth	120 mm
Weight	
Weight, approx.	550 g

Ordering data

FM 351 positioning module	6ES7 351-1AH02-0AE0
For rapid traverse and creep speed drives	
Front connector	
20-pin, with screw contacts	
• 1 unit	6ES7 392-1AJ00-0AA0
• 100 units	6ES7 392-1AJ00-1AB0
20-pin, with spring-loaded contacts	
• 1 unit	6ES7 392-1BJ00-0AA0
• 100 units	6ES7 392-1BJ00-1AB0
Bus connectors	6ES7 390-0AA00-0AA0
1 unit (spare part)	
Labeling strips	6ES7 392-2XX00-0AA0
10 units (spare part)	
Slot number label	6ES7 912-0AA00-0AA0
Labeling sheets for machine inscription	See under "Accessories", page 5/248
Spare part	
Shield connection element	6ES7 390-5AA00-0AA0
80 mm wide, with 2 rows for 4 terminals each	
Terminal elements	
2 units	
For 2 cables with 2 mm to 6 mm diameter	6ES7 390-5AB00-0AA0
For 1 cable with 3 mm to 8 mm diameter	6ES7 390-5BA00-0AA0
For 1 cable with 4 mm to 13 mm diameter	6ES7 390-5CA00-0AA0

Signal cables

Pre-assembled for HTL encoder, UL/DESINA

6FX5 0 2-2AL00-

Pre-assembled for SSI absolute encoder, UL/DESINA

6FX5 0 2-2CC11-

Pre-assembled for TTL encoder 6FX2001-1, UL/DESINA

6FX5 0 2-2CD01-

Pre-assembled for TTL encoder 24 V, UL/DESINA

6FX5 0 2-2CD24-

Not crimped

0

Module end crimped, connector case supplied

1

Motor end crimped, connector case supplied

4

0 m

100 m

200 m

1

2

3

0 m

10 m

20 m

30 m

40 m

50 m

60 m

70 m

80 m

90 m

A

B

C

D

E

F

G

H

J

K

0 m

1 m

2 m

3 m

4 m

5 m

6 m

7 m

8 m

0 m

A

B

C

D

E

F

G

H

J

K

0.0 m

0.1 m

0.2 m

0.3 m

0.4 m

0.5 m

0.6 m

0.7 m

0.8 m

0

1

2

3

4

5

6

7

8

Overview



- Extremely high-speed electronic cam controller
- Low-cost alternative to mechanical cam controllers
- 32 cam tracks, 13 onboard digital outputs for direct output of actions
- Incremental or synchro-serial position decoding

Note:

SIMODRIVE Sensor/Motion Connect 500 feature position-measuring systems and preassembled connecting cables for counting and positioning functions.

www.siemens.com/simatic-technology

Technical specifications

6ES7 352-1AH02-0AE0	
Supply voltage 24 V DC	Yes
Input current from load voltage L+ (without load), max.	200 mA
from backplane bus 5 V DC, max.	100 mA
Encoder supply 5 V encoder supply	Yes
• Output current, max.	300 mA
• Cable length, max.	32 m
24 V encoder supply	Yes
• Output current, max.	300 mA
• Cable length, max.	100 m
Digital inputs Number/binary inputs	4
Functions	Reference point switch, set floating actual value/length measurement, brake release, enable track output no. 3
Input voltage • Rated value, DC • for signal "0" • for signal "1"	24 V -30 to +5 V 11 to 30 V
Input current • for 2-wire sensor - for signal "0", typ. - for signal "1", typ.	2 mA 7 mA
Digital outputs Number/binary outputs	13
Functions	Cam track
Functionality/short-circuit strength	Yes
Output voltage • Rated value (DC) • for signal "1", min.	24 V UP - 0.8 V
Output current • for signal "1" permissible range for 0 to 60 °C, min. • for signal "1" permissible range for 0 to 60 °C, max. • for signal "0" residual current, max.	5 mA; with UPmax 600 mA; with UPmax 0.5 mA

6ES7 352-1AH02-0AE0	
Encoder Connectable encoders	
• Incremental encoder (symmetrical)	Yes
• Incremental encoder (asymmetrical)	Yes
• Absolute encoder (SSI)	Yes
• 2-wire sensor	Yes
- Permissible quiescent current (2-wire sensor), max.	2 mA
Encoder signals, incremental encoder (symmetrical) • Trace mark signals • Zero mark signal • Input signal • Input frequency, max.	A, notA, B, notB N, notN 5 V difference signal (phys. RS 422) 1 MHz
Encoder signals, incremental encoder (asymmetrical) • Trace mark signals • Zero mark signal • Input voltage • Input frequency, max.	A, B N 24 V 50 kHz; 50 kHz for 25 m cable length; 25 kHz for 100 m cable length
Encoder signals, absolute encoder (SSI) • Data signal • Clock signal • Message frame length, parameterizable • Clock frequency, max. • Gray code • Cable length, shielded, max.	DATA, notDATA CL, notCL 13 or 25 bit 1 MHz 1 320 m; at max. 125 kHz
Galvanic isolation Galvanic isolation digital inputs • Galvanic isolation digital inputs	No
Galvanic isolation digital outputs • Galvanic isolation digital outputs	No
Connection method required front connector	1x 20-pin
Dimensions Width	80 mm
Height	125 mm
Depth	120 mm
Weight Weight, approx.	550 g

SIMATIC S7-300

Function modules

FM 352 cam controllers

5

Ordering data	Order No.	Order No.
FM352 electronic cam controller	6ES7 352-1AH02-0AE0	
Sub D connector 15-pin, male	6ES5 750-2AA21	
Front connector 20-pin, with screw contacts • 1 unit • 100 units	6ES7 392-1AJ00-0AA0 6ES7 392-1AJ00-1AB0	
20-pin, with spring-loaded contacts • 1 unit • 100 units	6ES7 392-1BJ00-0AA0 6ES7 392-1BJ00-1AB0	
Bus connectors 1 unit (spare part)	6ES7 390-0AA00-0AA0	
Labeling strips 10 units (spare part)	6ES7 392-2XX00-0AA0	
Labeling sheets for machine inscription	See under "Accessories", page 5/248	
Slot number label Spare part	6ES7 912-0AA00-0AA0	
Shield connection element 80 mm wide, with 2 rows for 4 terminals each	6ES7 390-5AA00-0AA0	
Terminal elements 2 units For 2 cables with 2 mm to 6 mm diameter	6ES7 390-5AB00-0AA0	
For 1 cable with 3 mm to 8 mm diameter	6ES7 390-5BA00-0AA0	
For 1 cable with 4 mm to 13 mm diameter	6ES7 390-5CA00-0AA0	
	Signal cable	
	Pre-assembled for HTL encoder, UL/DESINA	6FX5 0 2-2AL00-
	Pre-assembled for SSI absolute encoder, UL/DESINA	6FX5 0 2-2CC11-
	Pre-assembled for TTL encoder 6FX2001-1, UL/DESINA	6FX5 0 2-2CD01-
	Pre-assembled for TTL encoder 24 V, UL/DESINA	6FX5 0 2-2CD24-
	Not crimped	0
	Module end crimped, connector case supplied	1
	Motor end crimped, connector case supplied	4
	0 m	1
	100 m	2
	200 m	3
	0 m	A
	10 m	B
	20 m	C
	30 m	D
	40 m	E
	50 m	F
	60 m	G
	70 m	H
	80 m	J
	90 m	K
	0 m	A
	1 m	B
	2 m	C
	3 m	D
	4 m	E
	5 m	F
	6 m	G
	7 m	H
	8 m	J
	0 m	K
	0.0 m	0
	0.1 m	1
	0.2 m	2
	0.3 m	3
	0.4 m	4
	0.5 m	5
	0.6 m	6
	0.7 m	7
	0.8 m	8

Overview



- The FM 352-5 high-speed Boolean processor provides extremely fast binary control and also some of the fastest switching processes ever possible (cycle time: 1 μ s).
- Programming is possible with LAD or FBD.
- The available set of statements comprises bit statements (partial statement set of STEP 7), timers, counters, frequency dividers, frequency generators, shift registers.
- 12 integral DI / 8 integral DO.
- 2 versions: Current sinking or current sourcing digital outputs.
- 1 channel for connection of a 24-V incremental encoder, a 5-V incremental encoder (RS422) or an SSI absolute-value sensor.

Micro memory card required for use of the FM 352-5

Note:

Displacement measuring systems and precut/preassembled cables for counting and positioning functions are available under SIMODRIVE Sensor or Motion Connect 500.

www.siemens.com/simatic-technology

5

Technical specifications

	6ES7 352-5AH01-0AE0	6ES7 352-5AH11-0AE0
Supply voltage 24 V DC	Yes	Yes
Load voltage L+		
• Rated value (DC)	24 V	24 V
• permissible range, lower limit (DC)	20.4 V	20.4 V
• permissible range, upper limit (DC)	28.8 V	28.8 V
• Reverse polarity protection	Yes	Yes
Input current from load voltage 1L+, max.	150 mA; typ. 60 mA	150 mA; typ. 60 mA
from load voltage 2L+ (without load), max.	200 mA; typ. 60 mA, DI/DO supply	200 mA; typ. 60 mA, DI/DO supply
from load voltage 3L+ (with encoder), max.	600 mA; typ. 80 mA plus encoder supply	600 mA; typ. 80 mA plus encoder supply
from load voltage 3L+ (without encoder), max.	200 mA; typ. 80 mA	200 mA; typ. 80 mA
from backplane bus 5 V DC, max.	135 mA; typ.	135 mA; typ.
Encoder supply 5 V encoder supply		
• 5 V	Yes	Yes
• Short-circuit protection	Yes; Electronic overload protection; no protection on applying a normal or counter voltage.	Yes; Electronic overload protection; no protection on applying a normal or counter voltage.
• Output current, max.	250 mA	250 mA
24 V encoder supply		
• 24 V	Yes	Yes
• Short-circuit protection	Yes; Overvoltage and overheating protection if overloaded; diagnostics if output reaches temperature limit; no protection on applying a normal or counter voltage	Yes; Overvoltage and overheating protection if overloaded; diagnostics if output reaches temperature limit; no protection on applying a normal or counter voltage
• Output current, max.	400 mA	400 mA
Power losses Power loss, typ.	6.5 W	6.5 W
Memory Memory card, RAM	128 kbyte; required for operation, MMC	128 kbyte; required for operation, MMC

SIMATIC S7-300

Function modules

FM 352-5 high-speed Boolean processor

Technical specifications (continued)

	6ES7 352-5AH01-0AE0	6ES7 352-5AH11-0AE0
Digital inputs		
Number/binary inputs	8; Standard and up to 12 with 24 V DC encoder inputs as digital inputs	8; Standard and up to 12 with 24 V DC encoder inputs as digital inputs
Input voltage		
• Rated value, DC	24 V	24 V
• for signal "0"	-30 to +5 V	-30 to +5 V
• for signal "1"	11 to 30 V	11 to 30 V
Input current		
• for signal "0", max. (permissible quiescent current)	1.5 mA	1.5 mA
• for signal "1", typ.	3.8 mA	3.8 mA
Input delay (for rated value of input voltage)		
• Input frequency (with a time delay of 0.1 ms), max.	200 kHz	200 kHz
• Programmable digital filter delay	None, 5 µs, 10 µs, 15 µs, 20 µs, 50 µs, 1.6 ms	None, 5 µs, 10 µs, 15 µs, 20 µs, 50 µs, 1.6 ms
• Minimum pulse width for program reactions	1 µs, 5 µs, 10 µs, 15 µs, 20 µs, 50 µs, 1.6 ms	1 µs, 5 µs, 10 µs, 15 µs, 20 µs, 50 µs, 1.6 ms
• for standard inputs - at "0" to "1", max.	3 µs; typ. 1.5 µs	3 µs; typ. 1.5 µs
Cable length		
• Cable length, shielded, max.	600 m	600 m
• Cable length unshielded, max.	100 m; Shielded cable recommended if filtering delay is set to less than 1.6 ms	100 m; Shielded cable recommended if filtering delay is set to less than 1.6 ms
Digital outputs		
Number/binary outputs	8	8
Current-sinking	Yes	No
Current-sourcing	No	Yes
Functionality/short-circuit strength	Yes; Overvoltage protection, thermal protection	Yes; Overvoltage protection, thermal protection
• Response threshold, typ.	1.7 to 3.5 A	1.7 to 3.5 A
Limitation of inductive shutdown voltage to	2M -45 V typ., (-40 to -55 V); comment: no protection against inductive kickback >55mJ	2M -45 V typ., (-40 to -55 V); comment: no protection against inductive kickback >55mJ
Lamp load, max.	5 W	5 W
Controlling a digital input	No	Yes
Output voltage		
• Rated value (DC)	24 V	24 V
• for signal "0", max.	28.8 V	28.8 V
• for signal "1", max.	0.5 V	0.5 V
Output current		
• for signal "1" rated value	0.5 A; At 60 °C	0.5 A; At 60 °C
• for signal "1" permissible range for 0 to 60 °C, min.	5 mA	5 mA
• for signal "1" permissible range for 0 to 60 °C, max.	600 mA	600 mA
• for signal "0" residual current, max.	1 mA	1 mA
Output delay with resistive load		
• "0" to "1", max.	1 µs; 0.6 µs 50 mA / 1.0 µs 0.5 A	1 µs; 0.6 µs 50 mA / 1.0 µs 0.5 A
• "1" to "0", max.	1.5 µs; 1.7 µs 50 mA / 1.5 µs 0.5 A	1.5 µs; 1.7 µs 50 mA / 1.5 µs 0.5 A
Parallel switching of 2 outputs		
• for increased power	Yes; 2	Yes; 2
Switching frequency		
• with resistive load, max.	100 kHz; 20 kHz at 0.5 A; 100 kHz at 0.25 A	100 kHz; 20 kHz at 0.5 A; 100 kHz at 0.25 A
• with inductive load, max.	2 Hz; 2 Hz at 0.5 A with external commutator diodes; 0.5 Hz at 0.5 A without external commutator diodes	2 Hz; 2 Hz at 0.5 A with external commutator diodes; 0.5 Hz at 0.5 A without external commutator diodes
• on lamp load, max.	10 Hz	10 Hz
Cable length		
• Cable length, shielded, max.	600 m	600 m
• Cable length unshielded, max.	100 m	100 m

Technical specifications (continued)

	6ES7 352-5AH01-0AE0	6ES7 352-5AH11-0AE0
Encoder		
Connectable encoders		
• Incremental encoder (symmetrical)	Yes	Yes
• Incremental encoder (asymmetrical)	Yes	Yes
• Absolute encoder (SSI)	Yes	Yes
• 2-wire sensor	Yes	Yes
- Permissible quiescent current (2-wire sensor), max.	1.5 mA	1.5 mA
Encoder signals, incremental encoder (symmetrical)		
• Trace mark signals	A, notA, B, notB	A, notA, B, notB
• Zero mark signal	N, notN	N, notN
• Input signal	5 V difference signal (phys. RS 422)	5 V difference signal (phys. RS 422)
• Input frequency, max.	500 kHz	500 kHz
• Cable length, shielded, max.	100 m; 100 m with 24 V supply and 500 kHz; 32 m with 5 V supply and 500 kHz	100 m; 100 m with 24 V supply and 500 kHz; 32 m with 5 V supply and 500 kHz
Encoder signals, incremental encoder (asymmetrical)		
• Trace mark signals	A, B	A, B
• Zero mark signal	N	N
• Input voltage	24 V	24 V
• Input frequency, max.	200 kHz	200 kHz
• Cable length, shielded, max.	50 m; Cable length, HTL incremental encoder, Siemens, type 6FX2001-4: 50 kHz, 25 m shielded, max., 25 kHz, 50 m shielded, max.	50 m; Cable length, HTL incremental encoder, Siemens, type 6FX2001-4: 50 kHz, 25 m shielded, max., 25 kHz, 50 m shielded, max.
Encoder signals, absolute encoder (SSI)		
• Data signal	DATA, notDATA	DATA, notDATA
• Clock signal	CK, notCK	CK, notCK
• Message frame length, parameterizable	13 or 25 bit	13 or 25 bit
• Clock frequency, max.	1 MHz; 125 kHz, 250 kHz, 500 kHz or 1 MHz	1 MHz; 125 kHz, 250 kHz, 500 kHz or 1 MHz
• Cable length, shielded, max.	320 m; At 125 kHz	320 m; At 125 kHz
• Monoflop time	settable: 16/32/48/64 µs	settable: 16/32/48/64 µs
• Listening mode	Yes; one or two stations	Yes; one or two stations
• Multiturn	Yes; 25 bit message frame	Yes; 25 bit message frame
Encoder signal evaluation		
• Counting direction, forward	Yes	Yes
• Counting direction, backward	Yes	Yes
Response times		
Input and output response time	5 V input to 24 V output, 0 filter: 1 to 4 µs (typ.); 24 V input to 24 V output, 0 filter: 2 to 6 µs (typ.)	5 V input to 24 V output, 0 filter: 1 to 4 µs (typ.); 24 V input to 24 V output, 0 filter: 2 to 6 µs (typ.)
Interfaces		
Point-to-point		
• Updating time	PLC interface: 1.7 ms	PLC interface: 1.7 ms
Interrupts/diagnostics/status information		
Alarms		
• Diagnostic alarm	Yes; 1L, 2L, 3L missing; MMC error; output overload (8); encoder supply overload; differential wire break; parameterization error; SSI message frame overflow	Yes; 1L, 2L, 3L missing; MMC error; output overload (8); encoder supply overload; differential wire break; parameterization error; SSI message frame overflow
• Hardware interrupt	Yes; 8 available; for generation by user program	Yes; 8 available; for generation by user program
Diagnostic messages		
• Wire break in signal transmitter cable	Yes	Yes
• Overflow/underflow	Yes	Yes
• Missing load voltage	Yes	Yes

SIMATIC S7-300

Function modules

FM 352-5 high-speed Boolean processor

Technical specifications (continued)

	6ES7 352-5AH01-0AE0	6ES7 352-5AH11-0AE0
Counter		
Counting range, description	Counting range (16-bit counters): -32,768 to 32,767 (user-specific within this range); counting range (32-bit counters): -2,147,483,648 to 2,147,483,647 (user-specific within this range)	Counting range (16-bit counters): -32,768 to 32,767 (user-specific within this range); counting range (32-bit counters): -2,147,483,648 to 2,147,483,647 (user-specific within this range)
Counting range, lower limit	-2147480000	-2147480000
Counting range, upper limit	2 147 480 000	2 147 480 000
Counting mode		
• Counting mode, individual	Yes	Yes
• Counting mode, continuous	Yes	Yes
• Counting mode, periodic	Yes	Yes
Galvanic isolation		
between 1L and 2L and 3L	Yes; 75 VDC / 60 VAC	Yes; 75 VDC / 60 VAC
between digital I/O and 2L and encoder I/O and 3L	Yes (75 V DC, 60 V AC)	Yes (75 V DC, 60 V AC)
between backplane bus and digital encoder I/O & 1L & 2L & 3L	Yes (75 V DC, 60 V AC)	Yes (75 V DC, 60 V AC)
Galvanic isolation digital inputs		
• Galvanic isolation digital inputs	Yes; Yes CPU, I/O and sensor units are isolated	Yes; Yes CPU, I/O and sensor units are isolated
Configuration		
programming		
• Program cycle time (scan)	1 µs	1 µs
Connection method		
required front connector	1x 40-pin	1x 40-pin
Dimensions		
Width	80 mm	80 mm
Height	125 mm	125 mm
Depth	120 mm	120 mm
Weight		
Weight, approx.	434 g; Module weight: approx. 434 g (with 1L connection and without I/O connection or MMC); shipping weight: approx. 500 g (with bus and 1L connection and without I/O connection or MMC)	434 g; Module weight: approx. 434 g (with 1L connection and without I/O connection or MMC); shipping weight: approx. 500 g (with bus and 1L connection and without I/O connection or MMC)

Ordering data

FM 352-5 high-speed Boolean processor

with current sinking digital outputs
with current sourcing digital outputs

6ES7 352-5AH01-0AE0

6ES7 352-5AH11-0AE0

Micro Memory Card

128 KB
512 KB
2 MB

6ES7 953-8LG20-0AA0

6ES7 953-8LJ30-0AA0

6ES7 953-8LL31-0AA0

Front connector

40-pin, with screw contacts

- 1 unit
- 100 units

40-pin, with spring-loaded contacts

- 1 unit
- 100 units

6ES7 392-1AM00-0AA0

6ES7 392-1AM00-1AB0

6ES7 392-1BM01-0AA0

6ES7 392-1BM01-1AB0

Signal cables

To HTL and TTL encoders, preassembled, without Sub-D connector

6FX5 002-2CA12-■■■■ 0

To SSI absolute encoders 6FX2 001-5, preassembled, without Sub-D connector

6FX5 002-2CC12-■■■■

Length code:

See FM 351, page 5/114

Overview



- Positioning module for stepper motors in machines with high clock-pulse rates
- Can be used for simple point-to-point positioning and for complex traversing profiles

5

Technical specifications

6ES7 353-1AH01-0AE0	
Supply voltage	
24 V DC	Yes
permissible range, lower limit (DC)	20.4 V
permissible range, upper limit (DC)	28.8 V
Input current	
Current consumption, max.	300 mA
Digital inputs	
Number/binary inputs	4; (+ 1 input for message signal)
Functions	Reference cams, flying actual value setting, flying measurement, start/stop positioning, external block change
Input voltage	
• Rated value, DC	24 V
• for signal "0"	-3 to +5 V
• for signal "1"	11 to 30 V
Input current	
• for signal "0", max. (permissible quiescent current)	2 mA
• for signal "1", typ.	6 mA; 6 to 15 mA
Digital outputs	
Number/binary outputs	4
Functions	Position reached: stop, axis travels forward, axis travels back, change M-function M97, change M-function M98, start enable, direct output via data record
Functionality/short-circuit strength	Yes
Output voltage	
• Rated value (DC)	24 V
• for signal "1", min.	UP -3 V
Output current	
• for signal "1" permissible range for 0 to 55 °C, max.	0.6 A; with UPmax
• for signal "0" residual current, max.	2 mA

6ES7 353-1AH01-0AE0	
Drive interface	
Signal input I	
• Function	"Power section ready"
Signal output I	
• Type	5 V difference signal (phys. RS 422)
• Function	Direction, enable, clock pulse, current control
• Differential output voltage, min.	2 V; RL = 100 Ohm
• Differential output voltage for signal "0", max.	1 V; lo = 20 mA
• Differential output voltage, for signal "1", min.	3.7 V; lo = -20 mA
• Cable length, max.	35 m
Galvanic isolation	
Galvanic isolation digital inputs	
• Galvanic isolation digital inputs	No
Galvanic isolation digital outputs	
• Galvanic isolation digital outputs	No
Connection method	
required front connector	1x 20-pin
Dimensions	
Width	80 mm
Height	125 mm
Depth	118 mm
Weight	
Weight, approx.	500 g

SIMATIC S7-300

Function modules

FM 353 positioning modules

Ordering data

FM 353 positioning module
For stepper motors;
incl. configuration package on
CD-ROM (Ge, En, Fr, It) comprising

- FM 353 manual, electronic
- Standard function blocks (STEP 7 interface software)
- Screen form-based configuration software for FM 353
- Standard interactive screen forms for OP7/OP17

Order No.

6ES7 353-1AH01-0AE0

FM 353 manual

German
English
French
Italian

6ES7 353-1AH01-8AG0

6ES7 353-1AH01-8BG0

6ES7 353-1AH01-8CG0

6ES7 353-1AH01-8EG0

Edit FM

Program editor for editing, loading
and saving NC programs with the
standard programming device/PC;
German/English, on CD-ROM

6FC5 263-0AA03-0AB0

Connecting cables

To stepper motor power section

6FX8 0 2-3AC02-■ ■ ■ ■ 0

Length code

See page 5/114

Connecting cables and encoders

See catalog NC 60, CA 01 or in the
Industry Mall

Sub D connector

15-pin, socket

6ES5 750-2AB21

Front connector

20-pin, with screw contacts

- 1 unit
- 100 units

6ES7 392-1AJ00-0AA0

6ES7 392-1AJ00-1AB0

20-pin, with spring-loaded contacts

- 1 unit
- 100 units

6ES7 392-1BJ00-0AA0

6ES7 392-1BJ00-1AB0

Order No.

Bus connectors

1 unit (spare part)

6ES7 390-0AA00-0AA0

Labeling strips

10 units (spare part)

6ES7 392-2XX00-0AA0

Labeling sheets for machine inscription

See under "Accessories",
page 5/248

Slot number label

Spare part

6ES7 912-0AA00-0AA0

Shield connection element

80 mm wide, with 2 rows for
4 terminals each

6ES7 390-5AA00-0AA0

Terminal elements

2 units

For 2 cables with
2 mm to 6 mm diameter

6ES7 390-5AB00-0AA0

For 1 cable with
3 mm to 8 mm diameter

6ES7 390-5BA00-0AA0

For 1 cable with
4 mm to 13 mm diameter

6ES7 390-5CA00-0AA0

Overview



- Positioning module for servo motors in machines with high clock pulse rates
- Can be used for point-to-point positioning tasks and for complex traversing patterns

Note:

SIMODRIVE Sensor/Motion Connect 500 feature position-measuring systems and preassembled connecting cables for counting and positioning functions.

www.siemens.com/simatic-technology

Technical specifications

6ES7 354-1AH01-0AE0	
Supply voltage 24 V DC	Yes
Input current Current consumption, max.	350 mA
Encoder supply 5 V encoder supply	Yes
• 5 V	Yes
• Output current, max.	220 mA
• Cable length, max.	35 m
24 V encoder supply	Yes
• 24 V	Yes
• Output current, max.	300 mA
• Cable length, max.	100 m
Digital inputs Number/binary inputs	4
Functions	Reference cams, flying actual value setting, flying measurement, start/stop positioning, external block change
Input voltage	
• Rated value, DC	24 V
• for signal "0"	-3 to +5 V
• for signal "1"	11 to 30 V
Input current	
• for signal "0", max.	2 mA
• (permissible quiescent current)	
• for signal "1", typ.	6 mA; 6 to 15 mA
Digital outputs Number/binary outputs	4
Functions	Position reached: stop, axis travels forward, axis travels back, change M-function M97, change M-function M98, start enable, direct output via data record
Functionality/short-circuit strength	Yes
Output voltage	
• Rated value (DC)	24 V
• for signal "1", min.	UP -3 V
Output current	
• for signal "1" permissible range for 0 to 55 °C, max.	0.6 A; with UPmax
• for signal "0" residual current, max.	2 mA

6ES7 354-1AH01-0AE0	
Encoder	
Connectable encoders	
• Incremental encoder (symmetrical)	Yes
• Absolute encoder (SSI)	Yes
Encoder signals, incremental encoder (symmetrical)	
• Trace mark signals	A, notA, B, notB
• Zero mark signal	N, notN
• Input signal	5 V difference signal (phys. RS 422)
• Input frequency, max.	1 MHz
Encoder signals, absolute encoder (SSI)	
• Input signal	5 V difference signal (phys. RS 422)
• Data signal	DATA, notDATA
• Clock signal	CL, notCL
• Message frame length, parameterizable	13, 21 or 25 bit
• Clock frequency, max.	1.25 Mbit/s
• Cable length, shielded, max.	100 m; 10 m at 1.25 Mbit/s, 100 m at max. 125 kbit/s
Drive interface	
Signal input I	
• Type	Input loop controller message, isolated (optocoupler) "Drive ready"
• Function	
• Input voltage, rated value (DC)	24 V
• Input voltage, for signal "0"	-3 to +5 V
• Input voltage, for signal "1"	15 to 30 V
• Input current, for signal "1"	2 to 6 mA
Signal output II	
• Type	Output closed-loop controller enable (contact)
• Function	Drive disconnection for operation via contact relay
• Load	1 A/50 V/30 VA DC
Signal output III	
• Type	Analog output
• Function	Setpoint output for drive
• Output voltage	-10 to +10 V
• Output current	-3 to +3 mA
• Cable length, max.	35 m

SIMATIC S7-300

Function modules

FM 354 positioning modules

Technical specifications (continued)

6ES7 354-1AH01-0AE0	
Galvanic isolation	
Galvanic isolation digital inputs	
• Galvanic isolation digital inputs	No
Galvanic isolation digital outputs	
• Galvanic isolation digital outputs	No
Connection method	
required front connector	1x 20-pin

6ES7 354-1AH01-0AE0	
Dimensions	
Width	80 mm
Height	125 mm
Depth	118 mm
Weight	
Weight, approx.	550 g

Ordering data

Ordering data	Order No.
FM 354 positioning module for servo motors, incl. configuration package on CD-ROM (Ge, En, Fr, It) comprising	6ES7 354-1AH01-0AE0
<ul style="list-style-type: none"> FM 354 manual, electronic Standard function blocks (STEP 7 interface software) Screen form-based configuration software for FM 354 Standard interactive screen forms for OP7/OP17 	
FM 354 manual	
German	6ES7 354-1AH01-8AG0
English	6ES7 354-1AH01-8BG0
French	6ES7 354-1AH01-8CG0
Italian	6ES7 354-1AH01-8EG0
Edit FM	6FC5 263-0AA03-0AB0
Program editor for editing, loading and saving NC programs with the standard programming device/PC; German/English, on CD-ROM	
Connecting cables	
To SSI absolute encoders 6FX2 001-5, preassembled	6FX5 0 2-2CC11-■■■■■
To incremental encoders 6FX2 001-1, preassembled	6FX5 0 2-2CD01-■■■■■
For 24 V incremental encoders, preassembled	6FX5 0 2-2CD24-■■■■■
To SIMODRIVE 611A, preassembled	6FX5 0 2-2CJ00-■■■■■
To SIMODRIVE 611U, preassembled	6FX5 0 2-2CJ10-■■■■■
To SSI absolute encoders 6FX2 001-5, preassembled, without Sub-D connector	6FX5 002-2CC12-■■■■■
To SSI absolute encoders 6FX2 001-5, preassembled, suitable for trailing	6FX8 0 2-2CC11-■■■■■
To incremental encoders 6FX2 001-2, preassembled, suitable for trailing	6FX8 0 2-2CD01-■■■■■
To SIMODRIVE 611A, preassembled, suitable for trailing	6FX8 0 2-2CJ00-■■■■■
To SIMODRIVE 611U, preassembled, suitable for trailing, 1 free end	6FX8 0 2-2CJ10-■■■■■
To SIMODRIVE 611A, preassembled, suitable for trailing, free ends	6FX8 0 2-3AB01-■■■■■
Length code	See page 5/114

Order No.

Ordering data	Order No.
Encoders	See catalog NC 60, CA 01 or in the Industry Mall
Front connector	
20-pin, with screw contacts	
• 1 unit	6ES7 392-1AJ00-0AA0
• 100 units	6ES7 392-1AJ00-1AB0
20-pin, with spring-loaded contacts	
• 1 unit	6ES7 392-1BJ00-0AA0
• 100 units	6ES7 392-1BJ00-1AB0
Bus connectors	6ES7 390-0AA00-0AA0
1 unit (spare part)	
Labeling strips	6ES7 392-2XX00-0AA0
10 units (spare part)	
Labeling sheets for machine inscription	See under "Accessories", page 5/248
Slot number label	6ES7 912-0AA00-0AA0
Spare part	
Shield connection element	6ES7 390-5AA00-0AA0
80 mm wide, with 2 rows for 4 terminals each	
Terminal elements	
2 units	
For 2 cables with 2 mm to 6 mm diameter	6ES7 390-5AB00-0AA0
For 1 cable with 3 mm to 8 mm diameter	6ES7 390-5BA00-0AA0
For 1 cable with 4 mm to 13 mm diameter	6ES7 390-5CA00-0AA0

Overview



- Path and positioning control for intelligent motion control of up to 4 axes
- Comprehensive range of application, from independent single positioning axes right up to interpolatory multi-axis path control
- For controlling stepper drives and controlled servo drive axes
- User-friendly commissioning with convenient parameterization tool
- Interface for SIMODRIVE 611U and MASTERDRIVES MC via isochronous PROFIBUS (not for FM 357-2H in conjunction with HT6)

Note:

Position measuring systems and preassembled connecting cables for counting and positioning functions are available under SIMODRIVE Sensor or Motion Connect 500.

Additional information is available on the Internet at:

www.siemens.com/simatic-technology

Technical specifications

6ES7 357-4AH01-0AE0	
Supply voltage 24 V DC	Yes
Input current from backplane bus 5 V DC, max.	100 mA
Encoder supply 5 V encoder supply	Yes
• 5 V	Yes
• Output current, max.	210 mA
• Cable length, max.	35 m
24 V encoder supply	Yes
• 24 V	Yes
• Output current, max.	300 mA
• Cable length, max.	100 m
Power Power consumption, typ.	24 W
Memory NC program memory	750 kbyte
Digital inputs Number/binary inputs	18
Functions	4 Bero, 2 probes, 12 for any use
Input voltage	24 V
• Rated value, DC	24 V
• for signal "0"	-3 to +5 V
• for signal "1"	11 to 30 V
Input current	2 mA
• for signal "0", max. (permissible quiescent current)	2 mA
• for signal "1", typ.	6 mA; 6 to 30 mA

6ES7 357-4AH01-0AE0	
Digital outputs Number/binary outputs	8
Functions	8 for any purpose
Output voltage	24 V
• Rated value (DC)	24 V
• for signal "1", min.	UP -3 V
Output current	0.5 A; with UPmax
• for signal "1" permissible range for 0 to 55 °C, max.	0.5 A; with UPmax
• for signal "0" residual current, max.	2 mA
Encoder Connectable encoders	Yes
• Incremental encoder (symmetrical)	Yes
• Absolute encoder (SSI)	Yes
Encoder signals, incremental encoder (symmetrical)	A, notA, B, notB
• Trace mark signals	N, notN
• Zero mark signal	5 V difference signal (phys. RS 422)
• Input signal	1 MHz
• Input frequency, max.	1 MHz
Encoder signals, absolute encoder (SSI)	5 V difference signal (phys. RS 422)
• Input signal	DATA, notDATA
• Data signal	CL, notCL
• Clock signal	13, 21 or 25 bit
• Message frame length, parameterizable	1.5 Mbit/s
• Clock frequency, max.	250 m; At max. 187.5 kbit/s
• Cable length, shielded, max.	
Positioning Programmable traverse speed, max.	1 000 m/min

SIMATIC S7-300

Function modules

FM 357-2 positioning modules

Technical specifications (continued)

6ES7 357-4AH01-0AE0	
Drive interface	
Signal output I	
• Type	5 V difference signal (phys. RS 422)
• Function	Direction, enable, clock pulse
• Differential output voltage, min.	2 V; RL = 100 Ohm
• Differential output voltage, for signal "0", max.	1 V; Io = 20 mA
• Differential output voltage, for signal "1", min.	3.7 V; Io = -20 mA
• Pulse frequency	750 kHz
• Cable length, max.	50 m; 35 m in hybrid mode with servo axes
Signal output II	
• Type	Controller release (contact), FM-READY output (contact)
• Function	Drive disconnection for operation via contact relay, Data set ready for link with Emergency STOP
• Load	1 A/50 V/30 VA DC
Signal output III	
• Type	Analog output
• Function	Drive interface for analog drives: setpoint output for drive
• Output voltage	-10 to +10 V
• Output current	-3 to +3 mA
• Cable length, max.	35 m

6ES7 357-4AH01-0AE0	
Galvanic isolation	
Galvanic isolation digital inputs	
• Galvanic isolation digital inputs	Yes
Galvanic isolation digital outputs	
• Galvanic isolation digital outputs	Yes
Connection method	
required front connector	1x 40-pin
Dimensions	
Width	200 mm
Height	125 mm
Depth	118 mm
Weight	
Weight, approx.	1 200 g

Ordering data

Ordering data	Order No.
FM 357-2 positioning module	6ES7 357-4AH01-0AE0
Basic unit	
System firmware	
incl. configuration package on CD-ROM, German, English, French, Italian, consisting of equipment manual (electronic), configuring software (parameterization screenforms, standard blocks, operator control and monitoring screenforms for OP17/OP27)	
FM 357-2L system firmware	6ES7 357-4AH03-3AE0
On memory card	
FM 357-2LX system firmware	6ES7 357-4BH03-3AE0
With additional functions; on memory card	
FM 357-H system firmware	6ES7 357-4CH03-3AE0
With additional functions for the handling sector; on memory card	
FM 357-2 manual	
German	6ES7 357-4AH00-8AG0
English	6ES7 357-4AH00-8BG0
French	6ES7 357-4AH00-8CG0
Italian	6ES7 357-4AH00-8EG0
Edit FM	6FC5 263-0AA03-0AB0
Program editor for editing, loading and saving NC programs with the standard programming device/PC; German/English, on CD-ROM	

Order No.

Connecting cables and encoders	See catalog NC 60, CA 01 or in the Industry Mall
Front connector	
40-pin, with screw contacts	
• 1 unit	6ES7 392-1AM00-0AA0
• 100 units	6ES7 392-1AM00-1AB0
40-pin, with spring-loaded contacts	
• 1 unit	6ES7 392-1BM01-0AA0
• 100 units	6ES7 392-1BM01-1AB0
Back-up battery	6ES7 971-1AA00-0AA0
Li-Ion, 3.6 V/0.95 Ah	
Signal cable	
Pre-assembled for SSI absolute encoder, UL/DESINA	6FX5 0 2-2CC11-■■■■■
Pre-assembled for TTL encoder 6FX2001-1, UL/DESINA	6FX5 0 2-2CD01-■■■■■
Pre-assembled for TTL encoder 24 V, UL/DESINA	6FX5 0 2-2CD24-■■■■■
Length code	see page 5/114

Overview



- 4-channel closed-loop control module for universal control tasks
- Can be used for temperature, pressure, flow and level controls
- Convenient online self-optimization for temperature controls
- Predefined controller structures
- 2 control algorithms
- 2 versions:
 - FM 355 C as continuous controller;
 - FM 355 S as step or pulse controller
- With 4 analog outputs (FM 355 C) or 8 digital outputs (FM 355 S) for direct control of the most common actuators
- Continuation of control mode also possible with CPU stop or failure

Technical specifications

	6ES7 355-0VH10-0AE0	6ES7 355-1VH10-0AE0
Supply voltage		
Load voltage L+		
• Rated value (DC)	24 V	24 V
• permissible range, lower limit (DC)	20.4 V	20.4 V
• permissible range, upper limit (DC)	28.8 V	28.8 V
Input current		
from load voltage L+ (without load), max.	310 mA; Typ. 260 mA	270 mA; typ. 220 mA
from backplane bus 5 V DC, max.	75 mA; typ. 50 mA	75 mA; typ. 50 mA
Power losses		
Power loss, typ.	6.5 W	5.5 W
Power loss, max.	7.8 W	6.9 W
Digital inputs		
Number/binary inputs	8	8
Input characteristic curve acc. to IEC 61131, Type 2	Yes	Yes
Input voltage		
• Rated value, DC	24 V	24 V
• for signal "0"	-3 to +5 V	-3 to +5 V
• for signal "1"	13 to 30 V	13 to 30 V
Input current		
• for signal "1", typ.	7 mA	7 mA
Cable length		
• Cable length, shielded, max.	1 000 m	1 000 m
• Cable length unshielded, max.	600 m	600 m
Digital outputs		
Number/binary outputs		8
Functionality/short-circuit strength		Yes; Electronic
Limitation of inductive shutdown voltage to		L+ (-1.5 V)
Lamp load, max.		5 W
Controlling a digital input		Yes
Load resistance range		
• lower limit		240 Ω
• upper limit		4 kΩ
Output voltage		
• for signal "1", min.		L+ (-2.5 V)

SIMATIC S7-300

Function modules

FM 355 controller modules

Technical specifications (continued)

	6ES7 355-0VH10-0AE0	6ES7 355-1VH10-0AE0
Output current		
• for signal "1" rated value		100 mA
• for signal "1" permissible range for 0 to 60 °C, min.		5 mA
• for signal "1" permissible range for 0 to 60 °C, max.		150 mA
• for signal "0" residual current, max.		0.5 mA
Parallel switching of 2 outputs		
• for logic links		Yes
Switching frequency		
• with resistive load, max.		100 Hz
• with inductive load, max.		0.5 Hz
• on lamp load, max.		100 Hz
Aggregate current of outputs (per group)		
• all mounting positions - up to 60 °C, max.		400 mA
Cable length		
• Cable length, shielded, max.		1 000 m
• Cable length unshielded, max.		600 m
Analog inputs		
Number of analog inputs	4	4
permissible input voltage for voltage input (destruction limit), max.	30 V	30 V
permissible input current for current input (destruction limit), max.	40 mA	40 mA
Input ranges (rated values), voltages		
• 0 to +10 V	Yes	Yes
• -1.75 to +11.75 V	Yes	Yes
• -80 mV to +80 mV	Yes	Yes
Input ranges (rated values), currents		
• 0 to 20 mA	Yes	Yes
• 0 to 23.5 mA	Yes	Yes
• -3.5 to +23.5 mA	Yes	Yes
• 4 to 20 mA	Yes	Yes
Input ranges (rated values), thermoelements		
• Type B	Yes	Yes
• Type J	Yes	Yes
• Type K	Yes	Yes
• Type R	Yes	Yes
• Type S	Yes	Yes
Input ranges (rated values), resistance thermometers		
• Pt 100	Yes	Yes
Thermocouple (TC)		
• for thermocouples	Type B, J, K, R, S	Type B, J, K, R, S
• Temperature compensation		
- internal temperature compensation	Yes	Yes
- external temperature compensation with Pt100	Yes	Yes
Resistance thermometer (RTD)		
• Characteristic linearization		
- for resistance thermometer	Pt100 (standard)	Pt100 (standard)
Characteristic linearization		
• Parameterizable	Yes	Yes
Cable length		
• Cable length, shielded, max.	200 m; 50 m at 80 mV and thermocouples	200 m; 50 m at 80 mV and thermocouples

Technical specifications (continued)

	6ES7 355-0VH10-0AE0	6ES7 355-1VH10-0AE0
Analog outputs		
Number of analog outputs	4	
Voltage output, short-circuit protection	Yes	
Voltage output, short-circuit current, max.	25 mA	
Current output, no-load voltage, max.	18 V	
Output ranges, voltage		
• 0 to 10 V	Yes	
• -10 to +10 V	Yes	
Output ranges, current		
• 0 to 20 mA	Yes	
• 4 to 20 mA	Yes	
Connection of actuators		
• for voltage output 2-conductor connection	Yes	
• for current output 2-conductor connection	Yes	
Load impedance (in rated range of output)		
• with voltage outputs, min.	1 k Ω	
• with voltage outputs, capacitive load, max.	1 μ F	
• with current outputs, max.	500 Ω	
• with current outputs, inductive load, max.	1 mH	
Cable length		
• Cable length, shielded, max.	200 m; 50 m at 80 mV and thermocouples	
Analog value creation		
Measurement principle	integrating	integrating
Integrations and conversion time/ resolution per channel		
• Resolution with overrange (bit including sign), max.	14 bit; 12 or 14 bit, parameterizable	14 bit; 12 or 14 bit, parameterizable
• Conversion time (per channel)	16.67 ms; for 12 bit: 16 2/3 ms for 60 Hz, 20 ms for 50 Hz; for 14 bit: 100 ms for 50 and 60 Hz	16.67 ms; for 12 bit: 16 2/3 ms for 60 Hz, 20 ms for 50 Hz; for 14 bit: 100 ms for 50 and 60 Hz
Settling time		
• for resistive load	0.2 ms	0.1 ms
• for capacitive load	3.3 ms	3.3 ms
• for inductive load	0.5 ms	0.5 ms
Encoder		
Connection of signal encoders		
• for voltage measurement	Yes	Yes
• for current measurement as 4-wire transducer	Yes	Yes
Connectable encoders		
• 2-wire sensor	Yes	Yes
- Permissible quiescent current (2-wire sensor), max.	1.5 mA	1.5 mA
Errors/accuracies		
Linearity error (relative to input area)	+/- 0,05 %	+/- 0,05 %
Temperature error (relative to input area)	+/- 0,005 %/K	+/- 0,005 %/K
Linearity error (relative to output area)	+/- 0,05 %	
Temperature error (relative to output area)	+/- 0,02 %/K	

SIMATIC S7-300

Function modules

FM 355 controller modules

Technical specifications (continued)

	6ES7 355-0VH10-0AE0	6ES7 355-1VH10-0AE0
Operational limit in overall temperature range		
<ul style="list-style-type: none"> • Voltage, relative to input area • Current, relative to input area • Resistance-type thermometer, relative to input area • Voltage, relative to output area • Current, relative to output area 	+/- 0,6 %; +/-0.6 to +/-1% +/- 0,6 %; +/-0.6 to +/-1% +/- 0,6 %; +/-0.6 to +/-1% +/- 0,5 % +/- 0,6 %	+/- 0,6 %; +/-0.6 to +/-1% +/- 0,6 %; +/-0.6 to +/-1% +/- 0,6 %; +/-0.6 to +/-1% +/- 0,5 % +/- 0,6 %
Basic error limit (operational limit at 25 °C)		
<ul style="list-style-type: none"> • Voltage, relative to input area • Current, relative to input area • Resistance-type thermometer, relative to input area • Voltage, relative to output area • Current, relative to output area 	+/- 0,4 %; 80 mV: +/-0.6%; 250 to 1000 mV: +/-0.4%; 2.5 to 10 V: +/-0.6%; 3.2 to 20 mA: +/-0.5% +/- 0,4 %; +/-0.4 to +/-0.6 % +/- 0,4 %; +/-0.4 to +/-0.6 % +/- 0,3 % +/- 0,5 %	+/- 0,4 %; 80 mV: +/-0.6%; 250 to 1000 mV: +/-0.4%; 2.5 to 10 V: +/-0.6%; 3.2 to 20 mA: +/-0.5% +/- 0,4 %; +/-0.4 to +/-0.6 % +/- 0,4 %; +/-0.4 to +/-0.6 %
Interference voltage suppression for $f = n \times (f_1 \pm 1\%)$, f_1 = interference frequency		
<ul style="list-style-type: none"> • Series mode interference (peak value of interference < rated value of input range), min. • common mode voltage (USS < 2.5 V), min. 	40 dB 70 dB	40 dB 70 dB
Interrupts/diagnostics/status information		
Substitute values connectable	Yes; Parameterizable	Yes; Parameterizable
Control technology		
Number of closed-loop controllers	4	4
Galvanic isolation		
Galvanic isolation controller		
<ul style="list-style-type: none"> • between the channels • between the channels and the backplane bus 	No Yes; Optocoupler	No Yes; Optocoupler
Permissible potential difference		
between inputs and MANA (UCM)	2.5 V DC	2.5 V DC
between M internally and the inputs	75 VDC / 60 VAC	75 VDC / 60 VAC
Isolation		
Isolation checked with	500 V DC	500 V DC
Connection method		
required front connector	2x 20-pin	2x 20-pin
Dimensions		
Width	80 mm	80 mm
Height	125 mm	125 mm
Depth	120 mm	120 mm
Weight		
Weight, approx.	470 g	470 g

SIMATIC S7-300

Function modules

FM 355 controller modules

Ordering data	Order No.	Ordering data	Order No.
FM 355 C controller module with 4 analog outputs for 4 continuous-action controllers	6ES7 355-0VH10-0AE0	Labeling sheets for machine inscription	See under "Accessories", page 5/248
FM 355 S controller module with 8 digital outputs for 4 step or pulse controllers	6ES7 355-1VH10-0AE0	Slot number label	6ES7 912-0AA00-0AA0
Front connector 20-pin, with screw contacts • 1 unit • 100 units	6ES7 392-1AJ00-0AA0 6ES7 392-1AJ00-1AB0	Spare part	
20-pin, with spring-loaded contacts • 1 unit • 100 units	6ES7 392-1BJ00-0AA0 6ES7 392-1BJ00-1AB0	Shield connection element 80 mm wide, with 2 rows for 4 terminals each	6ES7 390-5AA00-0AA0
Bus connectors 1 unit (spare part)	6ES7 390-0AA00-0AA0	Terminal elements 2 units	
Labeling strips 10 units (spare part)	6ES7 392-2XX00-0AA0	For 2 cables with 2 mm to 6 mm diameter	6ES7 390-5AB00-0AA0
		For 1 cable with 3 mm to 8 mm diameter	6ES7 390-5BA00-0AA0
		For 1 cable with 4 mm to 13 mm diameter	6ES7 390-5CA00-0AA0

SIMATIC S7-300

Function modules

FM 355-2 temperature controller modules

Overview



- 4-channel closed-loop controller module specifically for temperature controls
- Including integrated and easy-to-use online self-optimization
- Heating and cooling controllers as well as combined controllers with heating and active cooling function feasible
- Ready-to-use controller structures
- 2 versions:
 - FM 355-2 C as a continuous controller;
 - FM 355-2 S as step or pulse controllers
- With 4 analog outputs (FM 355-2 C) or 8 digital inputs (FM 355-2 S) to directly control the most common final control elements
- It is possible to continue closed-loop control operation even if the CPU stops or fails

Technical specifications

	6ES7 355-2CH00-0AE0	6ES7 355-2SH00-0AE0
Supply voltage		
Load voltage L+		
• Rated value (DC)	24 V	24 V
• permissible range, lower limit (DC)	20.4 V	20.4 V
• permissible range, upper limit (DC)	28.8 V	28.8 V
Input current		
from load voltage L+ (without load), max.	310 mA; Typ. 260 mA	270 mA; typ. 220 mA
from backplane bus 5 V DC, max.	75 mA; typ. 50 mA	75 mA; typ. 50 mA
Power losses		
Power loss, typ.	6.5 W	5.5 W
Power loss, max.	7.8 W	6.9 W
Digital inputs		
Number/binary inputs	8	8
Input characteristic curve acc. to IEC 61131, Type 2	Yes	Yes
Input voltage		
• Rated value, DC	24 V	24 V
• for signal "0"	-3 to +5 V	-3 to +5 V
• for signal "1"	13 to 30 V	13 to 30 V
Input current		
• for signal "1", typ.	7 mA	7 mA
Cable length		
• Cable length, shielded, max.	1 000 m	1 000 m
• Cable length unshielded, max.	600 m	600 m
Digital outputs		
Number/binary outputs		8
Functionality/short-circuit strength		Yes; Electronic
Limitation of inductive shutdown voltage to		L+ (-1.5 V)
Lamp load, max.		5 W
Controlling a digital input		Yes
Load resistance range		
• lower limit		240 Ω
• upper limit		4 kΩ

Technical specifications (continued)

	6ES7 355-2CH00-0AE0	6ES7 355-2SH00-0AE0
Output voltage • for signal "1", min.		L+ (-2.5 V)
Output current • for signal "1" rated value • for signal "1" permissible range for 0 to 60 °C, min. • for signal "1" permissible range for 0 to 60 °C, max. • for signal "0" residual current, max.		0.1 A 5 mA 150 mA 0.5 mA
Parallel switching of 2 outputs • for logic links		Yes
Switching frequency • with resistive load, max. • with inductive load, max. • on lamp load, max.		100 Hz 0.5 Hz 100 Hz
Aggregate current of outputs (per group) • all mounting positions - up to 60 °C, max.		400 mA
Cable length • Cable length, shielded, max. • Cable length unshielded, max.		1 000 m 600 m
Analog inputs		
Number of analog inputs	4	4
permissible input voltage for voltage input (destruction limit), max.	20 V	20 V
permissible input current for current input (destruction limit), max.	40 mA	40 mA
Input ranges (rated values), voltages • 0 to +10 V • -1.75 to +11.75 V	Yes Yes	Yes Yes
Input ranges (rated values), currents • 0 to 20 mA • 0 to 23.5 mA • -3.5 to +23.5 mA • 4 to 20 mA	Yes Yes Yes Yes	Yes Yes Yes Yes
Input ranges (rated values), thermoelements • Type B • Type E • Type J • Type K • Type R • Type S	Yes Yes Yes Yes Yes Yes	Yes Yes Yes Yes Yes Yes
Input ranges (rated values), resistance thermometers • Pt 100	Yes	Yes
Thermocouple (TC) • for thermocouples • Temperature compensation - internal temperature compensation - external temperature compensation with Pt100	Type B, E, J, K, R, S Yes Yes	Type B, E, J, K, R, S Yes Yes
Resistance thermometer (RTD) • Characteristic linearization - for resistance thermometer	Pt100 (standard)	Pt100 (standard)
Characteristic linearization • Parameterizable	Yes	Yes
Cable length • Cable length, shielded, max.	200 m; 50 m at 80 mV and thermocouples	200 m; 50 m at 80 mV and thermocouples

SIMATIC S7-300

Function modules

FM 355-2 temperature controller modules

Technical specifications (continued)

	6ES7 355-2CH00-0AE0	6ES7 355-2SH00-0AE0
Analog outputs		
Number of analog outputs	4	
Voltage output, short-circuit protection	Yes	
Voltage output, short-circuit current, max.	25 mA	
Current output, no-load voltage, max.	18 V	
Output ranges, voltage		
• 0 to 10 V	Yes	
• -10 to +10 V	Yes	
Output ranges, current		
• 0 to 20 mA	Yes	
• 4 to 20 mA	Yes	
Connection of actuators		
• for voltage output 2-conductor connection	Yes	
• for current output 2-conductor connection	Yes	
Load impedance (in rated range of output)		
• with voltage outputs, min.	1 k Ω	
• with voltage outputs, capacitive load, max.	1 μ F	
• with current outputs, max.	500 Ω	
• with current outputs, inductive load, max.	1 mH	
Cable length		
• Cable length, shielded, max.	200 m; 50 m at 80 mV and thermocouples	
Analog value creation		
Measurement principle	integrating	integrating
Integrations and conversion time/ resolution per channel		
• Resolution with overrange (bit including sign), max.	14 bit	14 bit
• Conversion time (per channel)	100 ms; At 50/60 Hz	100 ms; At 50/60 Hz
Settling time		
• for resistive load	0.2 ms	0.1 ms
• for capacitive load	3.3 ms	3.3 ms
• for inductive load	0.5 ms	0.5 ms
Encoder		
Connection of signal encoders		
• for voltage measurement	Yes	Yes
• for current measurement as 4-wire transducer	Yes	Yes
Connectable encoders		
• 2-wire sensor	Yes	Yes
- Permissible quiescent current (2-wire sensor), max.	1.5 mA	1.5 mA

Technical specifications (continued)

	6ES7 355-2CH00-0AE0	6ES7 355-2SH00-0AE0
Errors/accuracies		
Linearity error (relative to input area)	+/- 0,05 %	+/- 0,05 %
Temperature error (relative to input area)	+/- 0,005 %/K	+/- 0,005 %/K
Linearity error (relative to output area)	+/- 0,05 %	
Temperature error (relative to output area)	+/- 0,02 %/K	
Operational limit in overall temperature range		
• Voltage, relative to input area	+/- 0,6 %; +/-0.6 to +/-0.7%	+/- 0,06 %; +/-0.06 to +/-0.7%
• Current, relative to input area	+/- 0,6 %; +/-0.6 to +/-0.7%	+/- 0,06 %; +/-0.06 to +/-0.7%
• Resistance-type thermometer, relative to input area	+/- 0,6 %; +/-0.6 to +/-0.7%	+/- 0,06 %; +/-0.06 to +/-0.7%
• Voltage, relative to output area	+/- 0,5 %	
• Current, relative to output area	+/- 0,6 %	
Basic error limit (operational limit at 25 °C)		
• Voltage, relative to input area	+/- 0,04 %; +/-0.04 to +/-0.5%	+/- 0,04 %; +/-0.04 to +/-0.5%
• Current, relative to input area	+/- 0,04 %; +/-0.04 to +/-0.5%	+/- 0,04 %; +/-0.04 to +/-0.5%
• Resistance-type thermometer, relative to input area	+/- 0,04 %; +/-0.04 to +/-0.5%	+/- 0,04 %; +/-0.04 to +/-0.5%
• Voltage, relative to output area	+/- 0,4 %	
• Current, relative to output area	+/- 0,5 %	
Interference voltage suppression for $f = n \times (f_1 \pm 1\%)$, f_1 = interference frequency		
• Series mode interference (peak value of interference < rated value of input range), min.	40 dB	40 dB
• common mode voltage (USS < 2.5 V), min.	70 dB	70 dB
Interrupts/diagnostics/status information		
Substitute values connectable	Yes; Parameterizable	Yes; Parameterizable
Control technology		
Number of closed-loop controllers	4	4
Galvanic isolation		
Galvanic isolation controller		
• between the channels	No	No
• between the channels and the backplane bus	Yes; Optocoupler	Yes; Optocoupler
Permissible potential difference		
between inputs and MANA (UCM)	2.5 V DC	2.5 V DC
between M internally and the inputs	75 VDC / 60 VAC	75 VDC / 60 VAC
Isolation		
Isolation checked with	500 V DC	500 V DC
Connection method		
required front connector	2x 20-pin	2x 20-pin
Dimensions		
Width	80 mm	80 mm
Height	125 mm	125 mm
Depth	120 mm	120 mm
Weight		
Weight, approx.	470 g	470 g

SIMATIC S7-300

Function modules

FM 355-2 temperature controller modules

Ordering data

FM 355-2 C temperature controller module

with 4 analog outputs for
4 continuous-action controllers

Order No.

6ES7 355-2CH00-0AE0

FM 355-2 S temperature controller module

with 8 digital outputs for 4 step or
pulse controllers

6ES7 355-2SH00-0AE0

Front connector

20-pin, with screw contacts

- 1 unit
- 100 units

6ES7 392-1AJ00-0AA0
6ES7 392-1AJ00-1AB0

20-pin, with spring-loaded contacts

- 1 unit
- 100 units

6ES7 392-1BJ00-0AA0
6ES7 392-1BJ00-1AB0

Bus connectors

1 unit (spare part)

6ES7 390-0AA00-0AA0

Labeling strips

10 units (spare part)

6ES7 392-2XX00-0AA0

Labeling sheets for machine inscription

See under "Accessories",
page 5/248

Slot number label

Spare part

6ES7 912-0AA00-0AA0

Shield connection element

80 mm wide, with 2 rows for
4 terminals each

6ES7 390-5AA00-0AA0

Terminal elements

2 units

For 2 cables with 2 mm to 6 mm
diameter

6ES7 390-5AB00-0AA0

For 1 cable with 3 mm to 8 mm
diameter

6ES7 390-5BA00-0AA0

For 1 cable with 4 mm to 13 mm
diameter

6ES7 390-5CA00-0AA0

Overview



- Interface between max. 3 absolute-value sensors (SSI) and the CPU
- For provision of the displacement encoder values for further processing in STEP 7 programs
- Enables direct response of controller to encoder values in moving systems

Note:

Displacement measuring systems and precut/preassembled cables for counting and positioning functions are available under SIMODRIVE Sensor or Motion Connect 500.

www.siemens.com/simatic-technology

Technical specifications

6ES7 338-4BC01-0AB0	
Supply voltage	
Load voltage L+	
• Rated value (DC)	24 V
• permissible range, lower limit (DC)	20.4 V
• permissible range, upper limit (DC)	28.8 V
Input current	
from load voltage L+ (without load), max.	100 mA
from backplane bus 5 V DC, max.	160 mA
Encoder supply	
24 V encoder supply	
• 24 V	Yes; L+ (-0.8 V)
• Output current, max.	900 mA
Power losses	
Power loss, typ.	3 W
Digital inputs	
Input voltage	
• for signal "0"	-3 to +5 V
• for signal "1"	11 to 30.2 V
Input current	
• for signal "0", max. (permissible quiescent current)	2 mA
• for signal "1", typ.	9 mA
Input delay (for rated value of input voltage)	
• for standard inputs - at "0" to "1", min.	300 µs
Cable length	
• Cable length, shielded, max.	600 m

6ES7 338-4BC01-0AB0	
Encoder	
Number of connectable encoders, max.	3
Connectable encoders	
• Absolute encoder (SSI)	Yes
• 2-wire sensor	Yes
Encoder signals, absolute encoder (SSI)	
• Cable length, shielded, max.	320 m; 320 m at 125 kHz; 160 m at 250 kHz; 60 m at 500 kHz; 20 m at 1 MHz
Interrupts/diagnostics/status information	
Alarms	
• Diagnostic alarm	Yes
Galvanic isolation	
Galvanic isolation	No
Connection method	
required front connector	20-pin
Dimensions	
Width	40 mm
Height	125 mm
Depth	120 mm
Weight	
Weight, approx.	235 g

SIMATIC S7-300

Function modules

SM 338 POS input modules

Ordering data

SM 338 POS input module **6ES7 338-4BC01-0AB0**

For position sensing with 3 SSI encoders

Front connector

20-pin, with screw contacts

- 1 unit
- 100 units

6ES7 392-1AJ00-0AA0
6ES7 392-1AJ00-1AB0

20-pin, with spring-loaded contacts

- 1 unit
- 100 units

6ES7 392-1BJ00-0AA0
6ES7 392-1BJ00-1AB0

Front door, elevated design **6ES7 328-0AA00-7AA0**

e.g. for 32-channel modules;
for connecting 1.3 mm²/16 AWG
conductors

SIMATIC Manual Collection **6ES7 998-8XC01-8YE0**

Electronic manuals on DVD,
multilingual: LOGO!, SIMADYN,
SIMATIC bus components,
SIMATIC C7,
SIMATIC distributed I/O,
SIMATIC HMI, SIMATIC Sensors,
SIMATIC NET, SIMATIC PC Based
Automation, SIMATIC PCS 7,
SIMATIC PG/PC, SIMATIC S7,
SIMATIC Software, SIMATIC TDC

**SIMATIC Manual Collection
update service for 1 year** **6ES7 998-8XC01-8YE2**

Current "Manual Collection" DVD
and the three subsequent updates

S7-300 manual

Design, CPU data, module data,
instruction list

German

6ES7 398-8FA10-8AA0

English

6ES7 398-8FA10-8BA0

Signal cable

Pre-assembled for SSI absolute
encoder 6FX2001-5, without Sub-D
connector, UL/DESINA

6FX5 002-2CC12-■■■■

Length code

See page 5/114

Overview



- For connecting up to 4 drives with analog setpoint interface or pulse-direction interface to a controller
- Operation with isochronous PROFIBUS DP
- Connectable drives:
 - Electrical drives
 - Hydraulic drives
 - Stepper drives
- Can be used with:
 - SIMATIC CPU 41x-2 DP, CPU 31x-2 DP, CPU 31xT-2 DP, WinAC RTX 2008
 - SIMOTION C2xx, SIMOTION P350, SIMOTION D4x5
- Can also be used with external encoders

Technical specifications

6ES7 174-0AA10-0AA0	
Supply voltage	
24 V DC	Yes
permissible range, lower limit (DC)	20.4 V
permissible range, upper limit (DC)	28.8 V
Input current	
Current consumption, max.	500 mA
from backplane bus 5 V DC, max.	100 mA
Encoder supply	
5 V encoder supply	
• 5 V	Yes
• Output current, max.	1.2 A
• Cable length, max.	25 m
24 V encoder supply	
• 24 V	Yes
• Output current, max.	1.4 A
• Cable length, max.	100 m
Absolute encoder (SSI) encoder supply	
• Absolute encoder (SSI)	Yes
• Short-circuit protection	Yes
Power losses	
Power loss, typ.	12 W
Digital inputs	
Number/binary inputs	10
Input voltage	
• for signal "0"	-3 to +5 V
• for signal "1"	11 to 30 V
Input current	
• for signal "0", max. (permissible quiescent current)	2 mA
• for signal "1", typ.	8 mA
Input delay (for rated value of input voltage)	
• for standard inputs	
- at "0" to "1", min.	15 µs
Cable length	
• Cable length, shielded, max.	100 m

6ES7 174-0AA10-0AA0	
Digital outputs	
Number/binary outputs	8
Functionality/short-circuit strength	Yes
Lamp load, max.	30 W
Switching capacity of the outputs	
• with resistive load, max.	1 A
• on lamp load, max.	30 W
Output voltage	
• Rated value (DC)	24 V; L+
• for signal "1", min.	L+ (-3 V)
• for signal "1", max.	3 V
Output current	
• for signal "1" permissible range for 0 to 55 °C, min.	5 mA
• for signal "1" permissible range for 0 to 55 °C, max.	300 mA
• for signal "0" residual current, max.	0.4 mA
Output delay with resistive load	
• "0" to "1", max.	500 µs
Switching frequency	
• with resistive load, max.	500 Hz
• with inductive load, max.	0.5 Hz
Relay outputs	
• Number of relay outputs	4
• Number of operating cycles, max.	50 000
• Switching capacity of contacts	
- Switching frequency/contacts/ at ohmic load/maximum	1 A
Cable length	
• Cable length, shielded, max.	600 m
Analog outputs	
Number of analog outputs	4
Output ranges, voltage	
• -10 to +10 V	Yes
Analog value creation	
Integrations and conversion time/ resolution per channel	
• Resolution with overrange (bit including sign), max.	15 bit

SIMATIC S7-300

Function modules

IM 174 PROFIBUS modules

Technical specifications (continued)

6ES7 174-0AA10-0AA0	
Encoder	
Number of connectable encoders, max.	4
Connectable encoders	
• Incremental encoder (symmetrical)	Yes
• Absolute encoder (SSI)	Yes
• 2-wire sensor	Yes
- Permissible quiescent current (2-wire sensor), max.	2 mA
Encoder signals, incremental encoder (symmetrical)	
• Trace mark signals	A, notA, B, notB
• Zero mark signal	N, notN
• Input signal	5 V difference signal (phys. RS 422)
• Input frequency, max.	1 MHz
• Cable length, shielded, max.	35 m; 35 m at max. 500 kHz; 10 m at max. 1 MHz
Encoder signals, absolute encoder (SSI)	
• Input signal	5 V difference signal (phys. RS 422)
• Data signal	DATA, notDATA
• Clock signal	CL, notCL
• Message frame length, parameterizable	13, 21, 24 bit
• Clock frequency, max.	1.5 MHz; 187.5 KHz 1.5 MHz (parameterizable)
• Binary code	1
• Gray code	1
• Cable length, shielded, max.	250 m; 250 m at 187.5 kHz, 10 m at 1.5 MHz
Isochronous mode	
Isochronous operation (application synchronized up to terminal)	Yes
shortest clock pulse	1.5 ms
Interrupts/diagnostics/status information	
Alarms	
• Diagnostic alarm	Yes
Drive interface	
Number of drive interfaces	4
Analog drive	
• Setpoint signal	
- Short circuit proof	Yes; max. 45 mA, min. 3.3 kOhm load impedance
- Range of rated voltage	-10.5 V to +10.5 V
- Output current	-3 to +3 mA
• Output controller release	
- Number of relay contacts	4
- Switching voltage, max.	30 V
- Switching current, max.	1 A
- Switching capacity, max.	30 V·A
- Number of switching cycles, min.	50 000; at 30 V DC, 1 A
- Cable length (shielded), max.	35 m

6ES7 174-0AA10-0AA0	
Signal output I	
• Type	
- Number of relay contacts	2
• Differential output voltage, min.	
- Switching voltage, max.	30 V
• Differential output voltage for signal "0", max.	
- Switching current, max.	1 A
• Differential output voltage, for signal "1", min.	
- Switching capacity, max.	30 V·A
- Number of switching cycles, min.	50 000; at 30 V DC, 1 A
• Load impedance	
- Cable length (shielded), max.	35 m
Signal output II	
• Differential output voltage, min.	2 V; R = 100 Ohm
• Differential output voltage for signal "1", min.	3.7 V; 3.7 V at I = -20 mA; 4.5 V at I = -100 µA,
• Differential output voltage for signal "0", max.	1 V; For I = -20 mA
• Load resistance, min.	55 Ω
• Output current, max.	60 mA
Signal output III	
• Pulse frequency	750 kHz
• Cable length (shielded), max.	50 m; in hybrid operation with analog axes 35 m, in asymmetrical transmission 10 m
Galvanic isolation	
Galvanic isolation digital inputs	
• Galvanic isolation digital inputs	Yes; to encoders, analog outputs, DP interface; no to other DI/DOS
Galvanic isolation digital outputs	
• Galvanic isolation digital outputs	Yes; to encoders, analog outputs, DP interface; no to other DI/DOS
Connection method	
required front connector	40-pin
Dimensions	
Width	160 mm
Height	125 mm
Depth	118 mm
Weight	
Weight, approx.	1 kg

Ordering data

IM 174 PROFIBUS module
PROFIBUS module for connecting analog drives and stepper drives to a controller

Order No.

6ES7 174-0AA10-0AA0

Setpoint cable

for the connection between IM 174 and SIMODRIVE 611-A

for the connection between IM 174 with 3 stepper drives and one SIMODRIVE (end of cable cut off)

Length code

Order No.

6FX2 002-3AD01-■■■■

6FX2 002-3AD02-■■■■

See page 5/114

Overview



SIWAREX U is a versatile weighing module for all simple weighing and force measuring tasks. The compact module is easy to install in all SIMATIC automation systems. Complete data access is then possible via the SIMATIC.

5

Technical specifications

SIWAREX U	
Integration in automation systems:	
• S7-300	Direct integration
• S7-400 (H)	Via ET 200M
• PCS 7 (H)	Via ET 200M
• C7	Via IM or ET 200M
• Automation systems from other vendors	Via ET 200M
• Stand-alone (without SIMATIC CPU)	Possible with IM 153-1
Communication interfaces	<ul style="list-style-type: none"> • SIMATIC S7 (P bus) • RS 232 • TTY
Connection of remote displays (through TTY serial interface)	Gross, channel 1, 2 or default value 1, 2
Adjustment of scales settings	over SIMATIC (P bus) or PC using SIWATOOL U (RS 232)
Measuring properties	
Error limit to DIN 1319-1 of full-scale value at 20 °C ± 10 K	0.05 %
Internal resolution ADC	65535
Data format of weight values	2 byte (fixed-point)
Number of measurements/second	50
Digital filter	0.05 - 5 Hz (in 7 steps), mean-value filter
Weighing functions	
Weight values	Gross
Limit values	2 (min./max.)
Zero setting function	Per command
Load cells	Strain gages in 4-wire or 6-wire system

SIWAREX U	
Load cell powering	
Supply voltage U_s (rated value)	6 V DC ¹⁾
Max. supply current	≤ 150 mA per channel
Permissible load impedance	
• R_{Lmin}	> 40 Ω per channel
• R_{Lmax}	< 4010 Ω
With Ex(i) interface:	
• R_{Lmin}	> 87 Ω per channel
• R_{Lmax}	< 4010 Ω
Permissible load cell characteristic	Up to 4 mV/V
Max. distance of load cells	500 m ²⁾ 150/500 m for gas group IIC 500 m ²⁾ for gas group IIB (see SIWAREX IS Manual)
Intrinsically-safe load cell powering	Optional (Ex interface) with SIWAREX IS
Supply voltage 24 V DC	
Rated voltage	24 V DC
Max. current consumption	150 mA (single-channel) / 240 mA (two-channel)
Voltage supply from backplane bus	≤ 100 mA
Certification	ATEX 95, FM, cUL _{US} Haz. Loc.
IP degree of protection to DIN EN 60529; IEC 60529	IP20
Climatic requirements	
T_{min} (IND) to T_{max} (IND) (operating temperature)	
Vertical installation	0 ... +60 °C
Horizontal installation	0 ... +40 °C
EMC requirements according to	NAMUR NE21, Part 1 EN 61326
Dimensions	40 x 125 x 130 mm

¹⁾ Supply of load cells compared to 7MH4601-1AA01 or ... 1BA01 changed to 6 V DC.

²⁾ Up to 1000 m possible under certain conditions, provided the recommended cable is used (see Accessories).

SIMATIC S7-300

Function modules

SIWAREX U

Ordering data	Order No.	Order No.
SIWAREX U for SIMATIC S7 and ET 200M, incl. bus connector, weight 0.3 kg <ul style="list-style-type: none"> • Single-channel version¹⁾ for connecting one scale • Two-channel version²⁾ for connecting two scales 	7MH4950-1AA01 7MH4950-2AA01	Installation material (mandatory) 20-pin front plug with screw contacts (required for each SIWAREX U module) Shield contact element Sufficient for two SIWAREX U modules Shield connection terminal Contents: 2 units (suitable for cable with diameter 4 ... 13 mm) Note: one shield connection terminal each is required for: <ul style="list-style-type: none"> • Scale connection • RS 485 interface • RS 232 interface
SIWAREX U Manual <ul style="list-style-type: none"> • available in a range of languages Free download on the Internet at: www.siemens.com/weighing-technology		6ES7392-1AJ00-0AA0 6ES7390-5AA00-0AA0 6ES7390-5CA00-0AA0
SIWAREX U configuration package for SIMATIC S7 version 5.4 or higher on CD-ROM <ul style="list-style-type: none"> • PC SIWATOOL U software (available in a range of languages), new design • Sample program "Getting started" – ready to use application for SIMATIC S7 • SIWAREX U Manual on CD (in a range of languages), new design • HSP Hardware Support Package for integrating SIWAREX U in STEP 7 	7MH4950-1AK01	S7 DIN rail <ul style="list-style-type: none"> • 160 mm • 480 mm • 530 mm • 830 mm • 2000 mm
SIWAREX U configuration package for PCS 7, version 6.x suitable for 7MH4601-1*A01 and 7MH4950-*AA01 In German and English on CD-ROM, module for the CFC and faceplate	7MH4683-3BA64	Accessories (optional) PS 307 load power supplies (only required if 24 V DC not available) 120/230 V AC; 24 V DC, incl. power connector PS 307-1B; 2 A PS 307-1E; 5 A PS 307-1K; 10 A Labeling strips (10 units, spare part)
SIWAREX U configuration package for PCS7 version 7.0 and V7.1 suitable for 7MH4950-1AA01 and 7MH4950-2AA01 on CD-ROM <ul style="list-style-type: none"> • HSP Hardware Support • Package for integration of SIWAREX U in STEP 7 • Function block for the CFC chart • Faceplate • SIWATOOL U setting software • Manual 	7MH4950-3AK61	6ES7390-1AB60-0AA0 6ES7390-1AE80-0AA0 6ES7390-1AF30-0AA0 6ES7390-1AJ30-0AA0 6ES7390-1BC00-0AA0
SIWATOOL cable from SIWAREX U/CS with serial PC interface, for 9-pin PC interfaces (RS 232), 3 m long	7MH4607-8CA	Remote displays (option) The digital remote displays can be connected directly to SIWAREX U through a TTY interface. The following remote displays can be used: S102, S302 Siebert Industrieelektronik GmbH P.O. Box 1180 D-66565 Eppelborn Tel.: +49 6806/980-0 Fax: +49 6806/980-999 Internet: www.siebert.de Detailed information available from manufacturer.

¹⁾ Compatible with 7MH4601-1AA01; supply of load cells changed to 6 V DC.

²⁾ Compatible with 7MH4601-1BA01; supply of load cells changed to 6 V DC.

Ordering data	Order No.	Order No.
SIWAREX JB junction box, aluminium housing for connecting up to 4 load cells in parallel, and for connecting several junction boxes	7MH4710-1BA	
SIWAREX JB junction box, stainless steel housing for connecting up to 4 load cells in parallel	7MH4710-1EA	
Ex interface, type SIWAREX Pi With UL and FM approvals, but without ATEX approval for intrinsically-safe connection of load cells, suitable for the SIWAREX U, CS, MS, FTA and FTC weighing modules. Not approved for use in the EU.	7MH4710-5AA	
Manual for Ex interface type SIWAREX Pi	C71000-T5974-C29	
SIWAREX IS Ex interface With ATEX approval, but without UL and FM approvals , for intrinsically-safe connection of load cells, including manual, suitable for the SIWAREX U, CS, MS, FTA, FTC and CF weighing modules. Approved for use in the EU. <ul style="list-style-type: none"> • With short-circuit current < 199 mA DC • With short-circuit current < 137 mA DC 	7MH4710-5BA 7MH4710-5CA	
		Cable (optional) Cable Li2Y 1 x 2 x 0.75 ST + 2 x (2 x 0.34 ST) - CY, orange sheath to connect SIWAREX U, CS, MS, FTA, FTC and CF to the junction box (JB), extension box (EB) or Ex interface (Ex-I) or between two JB's, for fixed laying, occasional bending permitted, 10.8 mm outer diameter, for ambient temperature -40 to +80 °C
		7MH4702-8AG
		Cable Li2Y 1 x 2 x 0.75 ST + 2 x (2 x 0.34 ST) - CY, blue sheath to connect the junction box (JB) or extension box (EB) in a potentially explosive atmosphere to the Ex interface (Ex-I), for fixed laying, occasional bending permitted, blue PVC insulating sheath, approx. 10.8 mm outer diameter, for ambient temperature -40 to +80 °C
		7MH4702-8AF
		Cable LiYCY 4 x 2 x 0.25 mm² for TTY (connect 2 pairs of conductors in parallel), for connection of a remote display
		7MH4407-8BD0

SIMATIC S7-300

Function modules

SIWAREX FTA

Overview



The SIWAREX FTA (Flexible Technology, Automatic Weighing Instrument) is a versatile and flexible weighing module for industrial use. It can be used for automatic and non-automatic weighing, e.g. for the production of mixtures, filling, loading, monitoring and bagging.

It has been assigned appropriate scale approvals and is also suitable for calibration plants.

The SIWAREX FTA function module is integrated in SIMATIC S7/PCS7, and uses the features of this modern automation system, such as integral communication, diagnostics and configuration tools.

Technical specifications

SIWAREX FTA	
Use in automation systems	
S7-300	Directly or via ET 200M
S7-400 (H)	Via ET 200M
PCS 7 (H)	Via ET 200M
Communication interface	
S7	Through backplane bus
RS 232	For Siwatool or printer connection
RS 485	For remote display or digital load cell
Module parameterization	
	Using SIMATIC S7
	Using SIWATOOL FTA software (RS 232)
Measuring properties	
EU type approval as non-automatic weighing machine, trade class III	3 x 6000 d $\geq 0.5 \mu\text{V/e}$
Internal resolution	16 million parts
Internal/external updating rate	400/100 Hz
Several parameterizable digital filters	
	Critically dampened, Bessel, Butterworth (0.05 ... 20 Hz), mean-value filter
Weighing functions	
Non-automatic weighing machine	OIML R76
Automatic weighing machine	OIML R51, R61, R107
Load cells	
	Strain gages in 4-wire or 6-wire system
3 characteristic value ranges	1, 2 or 4 mV/V
Load cell powering	
Supply voltage U_S (rated value)	10.3 V DC
Max. supply current	184 mA
Permissible load cell resistance	
• $R_{L\text{min}}$	$> 56 \Omega$
• $R_{L\text{max}}$	$> 87 \Omega$ with Ex interface $\leq 4010 \Omega$

SIWAREX FTA	
Max. distance of load cells	
When using the recommended cable:	
Standard	1000 m (500 m legal-for-trade)
In hazardous area ¹⁾	
• For gases of group IIC	300 m
• For gases of group IIB	1000 m
Connection to load cells in Ex zone 1	
	Optionally via SIWAREX IS Ex interface
Ex approvals zone 2 and safety	
	ATEX 95, FM, cUL _{US} Haz. Loc.
Power supply	
Rated voltage	24 V DC
Max. current consumption	500 mA
Current consumption from backplane bus	Typ. 55 mA
Inputs/outputs	
Digital inputs	7 DI electrically isolated
Digital outputs	8 DO electrically isolated
Counter input	Up to 10 kHz
Analog output	
• Current range	0/4 ... 20 mA
• Updating rate	100 Hz
Approvals	
	EU type approval (CE, OIML R76)
	EU prototype test to MID (OIML R51, R61, R107)
Degree of protection to EN 60529; IEC 60529	
	IP20
Climatic requirements	
T_{min} (IND) ... T_{max} (IND) (operating temperature)	
Vertical installation	-10 ... 60 °C
Horizontal installation	-10 ... 40 °C
EMC requirements	
	EN 61326, EN 45501, NAMUR NE21, Part 1
Dimensions	
	80 x 125 x 130 mm
Weight	
	600 g

¹⁾ For further details, see Ex interface, type SIWAREX IS

Ordering data	Order No.	Order No.
SIWAREX FTA Legal-for-trade weighing electronics for automatic scales for S7-300 and ET 200M. EU type approval 3 x 6000 d Applications: proportioning, filling, bagging, loading. Note: Observe approval conditions for applications with obligation of verification. We recommend using our calibration set and contacting our SIWAREX hotline.	7MH4900-2AA01	
SIWAREX FTA Manual <ul style="list-style-type: none"> • available in a range of languages Free download from the Internet at: www.siemens.com/weighing-technology		
SIWAREX FTA "Getting started" Sample software shows beginners how to program the scales in STEP 7. Free download from the Internet at: www.siemens.com/weighing-technology		
SIWAREX FTA configuration package for SIMATIC S7 on CD-ROM <ul style="list-style-type: none"> • HSP Hardware Support Package for integrating SIWAREX FTA/FTC in STEP 7 • SIWAREX FTA "Getting started" • SIWATOOL FTA commissioning software • Flexible software for legal-for-trade display in WinCC • Manual 	7MH4900-2AK01	
SIWAREX FTA configuration package for PCS 7 V6.x on CD-ROM <ul style="list-style-type: none"> • HSP Hardware Support Package for integrating SIWAREX FTA/FTC in STEP 7 • Function block for CFC • Faceplate • SIWATOOL FTA commissioning software • Manual 	7MH4900-2AK61	
SIWAREX FTA configuration package for PCS 7 V7.0 on CD-ROM <ul style="list-style-type: none"> • HSP Hardware Support Package for integrating SIWAREX FTA/FTC in STEP 7 • Function block for CFC • Faceplate • SIWATOOL FTA commissioning software • Manual 	7MH4900-2AK62	
Calibration set for SIWAREX FTA For verification of up to 5 scales comprising: <ul style="list-style-type: none"> • 3 x inscription foil for labeling • 1 x protection foil • 10 x EU verification marks (black M on green background) • Guidelines for verification, verification certificates and approvals, adaptable label, SIWAREX FTA Manual on CD-ROM 	7MH4900-2AY10	
		SIWAREX Multiscale STEP 7 software for SIWAREX FTA. Control of one or more scales for a scalable number of components and any number of recipes. Applications: batching plants, mixers in production process, CD-ROM
		SIWAREX Multifill STEP 7 software for SIWAREX FTA. Control of filling and bagging processes for one or more filling stations and any number of materials, CD-ROM
		SIWATOOL cable from SIWAREX FTA with serial PC interface, for 9-pin PC interfaces (RS 232) <ul style="list-style-type: none"> • 2 m long • 5 m long
		40-pin front plug with screw contacts (required for each SIWAREX module), alternatively with spring-loaded contacts
		40-pin front plug with spring-loaded contacts (required for each SIWAREX module), alternatively with screw contacts
		Shield contact element Sufficient for one SIWAREX FTA module
		Shield connection terminal Contents: 2 units (suitable for cable with diameter 4 ... 13 mm) Note: one shield connection terminal each is required for: <ul style="list-style-type: none"> • Scale connection • RS 485 interface • RS 232 interface
		S7 DIN rail <ul style="list-style-type: none"> • 160 mm • 480 mm • 530 mm • 830 mm • 2000 mm
		PS 307 load power supply (only required if DC 24 V is not available) 120/230 V AC; 24 V DC <ul style="list-style-type: none"> • PS 307-1B; 2 A • PS 307-1E; 5 A • PS 307-1K; 10 A
		MMC memory for data recording up to 16 MB
		7MH4900-2AL01
		7MH4900-2AM01
		7MH4702-8CA 7MH4702-8CB
		6ES7392-1AM00-0AA0
		6ES7392-1BM01-0AA0
		6ES7390-5AA00-0AA0
		6ES7390-5CA00-0AA0
		6ES7390-1AB60-0AA0 6ES7390-1AE80-0AA0 6ES7390-1AF30-0AA0 6ES7390-1AJ30-0AA0 6ES7390-1BC00-0AA0
		6ES7307-1BA00-0AA0 6ES7307-1EA00-0AA0 6ES7307-1KA00-0AA0
		7MH4900-2AY20

SIMATIC S7-300

Function modules

SIWAREX FTA

Ordering data

Remote display (optional)

The Siebert S102 and S302 remote digital display can be directly connected to the SIWAREX FTA via an RS 485 interface.

Siebert Industrieelektronik GmbH
P.O. Box 1180
D-66565 Eppelborn
Tel.: +49 6806/980-0
Fax: +49 6806/980-999
Internet: www.siebert.de

Detailed information available from manufacturer.

SIWAREX JB junction box, aluminium housing

7MH4710-1BA

for connecting up to 4 load cells in parallel, and for connecting several junction boxes

SIWAREX JB junction box, stainless steel housing

7MH4710-1EA

for connecting up to 4 load cells in parallel

Ex interface, type SIWAREX Pi

7MH4710-5AA

With UL and FM approvals, but **without ATEX approval** for intrinsically-safe connection of load cells, suitable for the SIWAREX U, CS, MS, FTA and FTC weighing modules. Not approved for use in the EU.

Manual for Ex interface type SIWAREX Pi

C71000-T5974-C29

Ex interface, type SIWAREX IS

With ATEX approval, but **without UL and FM approvals** for intrinsically-safe connection of load cells, including manual, suitable for the SIWAREX U, CS, MS, FTA, FTC and CF weighing modules. Approved for use in the EU.

- With short-circuit current < 199 mA DC
- With short-circuit current < 137 mA DC

7MH4710-5BA

7MH4710-5CA

Cable (optional)

Cable Li2Y 1 x 2 x 0.75 ST + 2 x (2 x 0.34 ST) - CY, orange sheath

to connect SIWAREX U, CS, MS, FTA, FTC and CF to the junction box (JB), extension box (EB) or Ex interface (Ex-I) or between two JBs, for fixed laying, occasional bending permitted, 10.8 mm outer diameter, for ambient temperature -40 to +80 °C

7MH4702-8AG

Cable Li2Y 1 x 2 x 0.75 ST + 2 x (2 x 0.34 ST) - CY, blue sheath

to connect the junction box (JB) or extension box (EB) in a potentially explosive atmosphere to the Ex interface (Ex-I), for fixed laying, occasional bending permitted, blue PVC insulating sheath, approx. 10.8 mm outer diameter, for ambient temperature -40 ... +80 °C

7MH4702-8AF

Cable LiYCY 4 x 2 x 0.25 mm²

7MH4407-8BD0

for TTY (connect 2 pairs of conductors in parallel), for connection of a remote display

Overview



The SIWAREX FTC (Flexible Technology for Continuous Weighing) is a versatile and flexible weighing module for conveyor scales, loss-in-weigh scales and bulk flow meters. It can also be used to record weights and measure force. The SIWAREX FTC function module is integrated in SIMATIC S7/PCS7, and uses the features of this modern automation system, such as integral communication, diagnostics and configuration tools.

Technical specifications

SIWAREX FTC	
Use in automation systems	
S7-300	Directly or via ET 200M
S7-400 (H)	Via ET 200M
PCS 7 (H)	Via ET 200M
Communication interfaces	
S7	Through backplane bus
RS 232	For SIWATOOL or printer connection
RS 485	For remote display or digital load cell
Module parameterization	Using SIMATIC S7 Using SIWATOOL FTC software (RS 232)
Measuring properties	
Accuracy to EN 45501	3 x 6000 d ≥ 0.5 μV/e
Internal resolution	+/- 8 million parts
Internal/external updating rate	400/100 Hz
Several parameterizable digital filters	Critically dampened, Bessel, Butterworth (0.05 ... 20 Hz), mean-value filter
Weighing functions	<ul style="list-style-type: none"> • Non-automatic weighing machine, force measurement • Conveyor scale • Differential proportioning weigher • Bulk flow meter
Load cells	Strain gages in 4-wire or 6-wire system
3 characteristic value ranges	1, 2 or 4 mV/V
Load cell powering	
Supply voltage U_S (rated value)	10.3 V DC
Max. supply current	184 mA
Permissible load cell resistance	
• R_{Lmin}	> 56 Ω
• R_{Lmax}	> 87 Ω with Ex interface ≤ 4010 Ω

SIWAREX FTC	
Max. distance of load cells	
When using the recommended cable:	
Standard	1000 m
In hazardous area ¹⁾	
• For gases of group IIC	300 m
• For gases of group IIB	1000 m
Connection to load cells in Ex zone 1	Optionally via SIWAREX IS Ex interface
Ex approvals zone 2 and safety	ATEX 95, FM, cUL _{US} Haz. Loc.
Power supply	
Rated voltage	24 V DC
Max. current consumption	500 mA
Current consumption from backplane bus	Typ. 55 mA
Inputs/outputs	
Digital inputs	7 DI electrically isolated
Digital outputs	8 DO electrically isolated
Counter input	Up to 10 kHz
Analog output	
• Current range	0/4 ... 20 mA
• Updating rate	100 Hz
Degree of protection to DIN EN 60529; IEC 60529	IP20
Climatic requirements	
T_{min} (IND) ... T_{max} (IND) (operating temperature)	
Vertical installation	-10 ... 60 °C
Horizontal installation	-10 ... 40 °C
EMC requirements	EN 61326, EN 45501, NAMUR NE21, Part 1
Dimensions	80 x 125 x 130 mm
Weight	600 g

¹⁾ For further details, see Ex interface, type SIWAREX IS

SIMATIC S7-300

Function modules

SIWAREX FTC

Ordering data

Order No.

Order No.

SIWAREX FTC

Weighing electronics for S7-300 and ET 200M.

Applications: Belt scales, force measurement, loss-in-weight scales and bulk flow meters

SIWAREX FTC_B Manual for belt scales

- Available in a range of languages

Free download from the Internet at: www.siemens.com/weighing-technology

SIWAREX FTC_L Manual for bulk flow meters and loss-in-weight scales

- Available in a range of languages

Free download from the Internet at: www.siemens.com/weighing-technology

SIWAREX FTC "Getting started" for belt scales

Sample software shows beginners how to program the scales in STEP 7 for belt scale mode

Free download from the Internet at: www.siemens.com/weighing-technology

SIWAREX FTC "Getting started" for bulk flow meters

Sample software shows beginners how to program the scales in STEP 7 for bulk flow meter mode

Free download from the Internet at: www.siemens.com/weighing-technology

SIWAREX FTC "Getting started" for loss-in-weight scales

Sample software shows beginners how to program the scales in STEP 7 for loss-in-weight scale mode

Free download from the Internet at: www.siemens.com/weighing-technology

SIWAREX FTC_B configuration package for SIMATIC S7 on CD-ROM (belt scale)

- HSP Hardware Support Package for integrating SIWAREX FTA/FTC in STEP 7
- "Getting started" for belt scales
- Commissioning software SIWATOOL FTC_B for belt scales
- Manual

SIWAREX FTC_L configuration package for SIMATIC S7 on CD-ROM (bulk flow meter, loss-in-weight feeder)

- HSP Hardware Support Package for integrating SIWAREX FTA/FTC in STEP 7
- "Getting started" for bulk flow meters
- "Getting started" for loss-in-weight feeders
- Commissioning software SIWATOOL_L for bulk flow meters and loss-in-weight feeders
- Manual

7MH4900-3AA01

7MH4900-3AK01

7MH4900-3AK02

SIWAREX FTC_B configuration package for PCS 7 V6.x on CD-ROM (belt scale)

- HSP Hardware Support Package for integrating SIWAREX FTA/FTC in STEP 7
- Function block for CFC
- Faceplate
- Commissioning software SIWATOOL FTC_B for belt scales
- Manual

SIWAREX FTC_B configuration package for PCS 7 V7.0 on CD-ROM (belt scale)

- HSP Hardware Support Package for integrating SIWAREX FTA/FTC in STEP 7
- Function block for CFC
- Faceplate
- Commissioning software SIWATOOL FTC_B for belt scales
- Manual

SIWAREX FTC_L configuration package for PCS 7 V7.0 and V7.1 on CD-ROM (loss-in-weight feeder)

- HSP Hardware Support Package for integrating SIWAREX FTA/FTC in STEP 7
- Function block for CFC
- Faceplate
- Commissioning software SIWATOOL FTC_L for bulk flow meters and loss-in-weight feeders
- Manual

SIWATOOL cable from SIWAREX FTC with serial PC inter- face, for 9-pin PC interfaces (RS 232)

- 2 m long
- 5 m long

40-pin front plug with screw contacts

(required for each SIWAREX module), alternatively with spring-loaded contacts

40-pin front plug with spring-loaded contacts

(required for each SIWAREX module), alternatively with screw contacts

Shield contact element

Sufficient for one SIWAREX FTC module

Shield connection terminal

Contents: 2 units (suitable for cable with diameter 4 ... 13 mm)

Note:
one shield connection terminal each is required for:

- Scale connection
- RS 485 interface
- RS 232 interface

S7 DIN rail

- 160 mm
- 480 mm
- 530 mm
- 830 mm
- 2000 mm

7MH4900-3AK61

7MH4900-3AK63

7MH4900-3AK64

7MH4702-8CA
7MH4702-8CB

6ES7392-1AM00-0AA0

6ES7392-1BM01-0AA0

6ES7390-5AA00-0AA0

6ES7390-5CA00-0AA0

6ES7390-1AB60-0AA0
6ES7390-1AE80-0AA0
6ES7390-1AF30-0AA0
6ES7390-1AJ30-0AA0
6ES7390-1BC00-0AA0

Ordering data	Order No.	Order No.
<p>PS 307 load power supply (only required if DC 24 V is not available)</p> <p>120/230 V AC; 24 V DC</p> <ul style="list-style-type: none"> • PS 307-1B; 2 A • PS 307-1E; 5 A • PS 307-1K; 10 A 	<p>6ES7307-1BA00-0AA0 6ES7307-1EA00-0AA0 6ES7307-1KA00-0AA0</p>	
<p>MMC memory for data recording up to 16 MByte</p>	7MH4900-2AY20	
<p>Remote display (optional)</p> <p>The Siebert S102 and S302 remote digital display can be directly connected to the SIWAREX FTC via an RS 485 interface. (not suitable for mode "Belt scale")</p> <p>Siebert Industrieelektronik GmbH P.O. Box 1180 D-66565 Eppelborn Tel.: +49 6806/980-0 Fax: +49 6806/980-999 Internet: www.siebert.de</p> <p>Detailed information available from manufacturer.</p>		
<p>SIWAREX JB junction box, aluminium housing</p> <p>for connecting up to 4 load cells in parallel, and for connecting several junction boxes</p>	7MH4710-1BA	
<p>SIWAREX JB junction box, stainless steel housing</p> <p>for connecting up to 4 load cells in parallel</p>	7MH4710-1EA	
<p>Ex interface, type SIWAREX Pi</p> <p>With UL and FM approvals, but without ATEX approval for intrinsically-safe connection of load cells, suitable for the SIWAREX U, CS, MS, FTA and FTC weighing modules. Not approved for use in the EU.</p>	7MH4710-5AA	
<p>Manual for Ex interface type SIWAREX Pi</p>	C71000-T5974-C29	
<p>Ex interface, type SIWAREX IS</p> <p>With ATEX approval, but without UL and FM approvals for intrinsically-safe connection of load cells, including manual, suitable for the SIWAREX U, CS, MS, FTA, FTC and CF weighing modules. Approved for use in the EU.</p> <ul style="list-style-type: none"> • With short-circuit current < 199 mA DC • With short-circuit current < 137 mA DC 	<p>7MH4710-5BA</p> <p>7MH4710-5CA</p>	
		<p>Cable (optional)</p> <p>Cable Li2Y 1 x 2 x 0.75 ST + 2 x (2 x 0.34 ST) - CY, orange sheath</p> <p>to connect SIWAREX U, CS, MS, FTA, FTC and CF to the junction box (JB), extension box (EB) or Ex interface (Ex-I) or between two JBs, for fixed laying, occasional bending permitted, 10.8 mm outer diameter, for ambient temperature -40 ... +80 °C</p>
		7MH4702-8AG
		<p>Cable Li2Y 1 x 2 x 0.75 ST + 2 x (2 x 0.34 ST) - CY, blue sheath</p> <p>to connect the junction box (JB) or extension box (EB) in a potentially explosive atmosphere to the Ex interface (Ex-I), for fixed laying, occasional bending permitted, blue PVC insulating sheath, approx. 10.8 mm outer diameter, for ambient temperature -40 ... +80 °C</p>
		7MH4702-8AF
		<p>Cable LiYCY 4 x 2 x 0.25 mm²</p> <p>for TTY (connect 2 pairs of conductors in parallel), for connection of a remote display</p>
		7MH4407-8BD0

SIMATIC S7-300

Function modules

SIFLOW FC070

Overview



SIFLOW FC070 is based on the latest developments within the digital processing technology – engineered for high performance, fast flow step response, immunity against process generated noise, easy to install, commission and maintain.

SIFLOW FC070 is available in two versions:

- SIFLOW FC070 Standard
- SIFLOW FC070 Ex CT

The SIFLOW FC070 transmitter delivers true multi-parameter measurements i.e. mass flow, volume flow, density, temperature and fraction.

SIFLOW FC070 is designed for integration in a variety of automation systems, i.e.:

- Central mounted in S7-300, C7
- Decentralized in ET 200M for use with S7-300 and S7-400 as PROFIBUS DP/PROFINET masters
- Decentralized in ET 200M for use with any automation system using standardized PROFIBUS DP/PROFINET masters
- Stand-alone via a Modbus RTU master, i.e. SIMATIC PDM

The SIFLOW FC070 transmitter can be connected to all sensors of types MASS 2100, MC2, FCS200 and FC300.

Technical specifications

Measurement of	Mass flow, volume flow, density, sensor temperature, fraction A flow, fraction B flow, fraction A in %
Measurement functions	<ul style="list-style-type: none"> • Totalizer 1 • Totalizer 2 • Single and 2-stage batch function • 4 programmable limits
Digital input	<p>Start batch, stop batch, start/stop batch, hold/continue batch, reset totalizer 1, reset totalizer 2, reset totalizer 1 and 2, zero adjust, force frequency output, freeze frequency output</p> <p>High signal</p> <ul style="list-style-type: none"> • Nominal voltage: 24 V DC • Lower limit: 15 V DC • Upper limit: 30 V DC • Current: 2 ... 15 mA <p>Low signal</p> <ul style="list-style-type: none"> • Nominal voltage: 0 V DC • Lower limit: -3 V DC • Upper limit: 5 V DC • Current: -15 ... +15 mA <p>Input</p> <p>Switching</p> <p>Approx. 10 kΩ</p> <p>Max. 100 Hz</p>

Digital output 1 and 2	
Functions	<ul style="list-style-type: none"> • Output 1: Pulse, frequency, redundancy pulse, redundancy frequency, 2-stage batch, batch • Output 2: Redundancy pulse, redundancy frequency, 2-stage batch
Voltage supply	3 ... 30 V DC (passive output)
Switching current	Max. 30 mA at 30 V DC
Voltage drop	≤ 3 V DC at max. current
Leakage current	≤ 0.4 mA at max. voltage 30 V DC
Load resistance	1 ... 10 kΩ
Switching frequency	0 ... 12 kHz 50 % duty cycle
Functions	Pulse, frequency, redundancy pulse, redundancy frequency, 2-stage batch, batch
Communication	
Modbus RS 232C	<ul style="list-style-type: none"> • Max. baudrate: 115 200 baud • Max. line length: 15 m at 115 200 baud • Signal level: according to EIA-RS232C
Modbus RS 485	<ul style="list-style-type: none"> • Max. baudrate: 115 200 baud • Max. line length: 1200 m at 115 200 baud • Signal level: according to EIA-RS485 • Bus termination: Integrated. Can be enabled by inserting wire jumpers.
Galvanic isolation	All inputs, outputs and communication interfaces are galvanically isolated. Isolation voltage: 500 V.

Technical specifications (continued)

Power		Approvals Custody transfer	
Supply	24 V DC nominal	SIFLOW FC070 Ex CT	PTB Germany approval no.: 5.4.11/11.22
Tolerance	20.4 V DC ... 28.8 V DC		OIML R 139 - Compressed gaseous fuel measuring systems for vehicles
Consumption	Max. 7.2 W	Electromagnetic compatibility	
Fuse	T1 A/125 V, not replaceable by operator		Requirements of EMC law; Noise immunity according to IEC 61000-6-2, tested according to: IEC 61000-4-2, IEC 61000-4-3, IEC 61000-4-4, IEC 61000-4-5, IEC 61000-4-6
Environment			Emitted interference according to EN 50081-2, tested according to: EN 55011, class A, group 1
Ambient temperature	Storage -40 °C ... +70 °C (-40 °F ... +158 °F)	NAMUR	
Operation conditions	Horizontally mounted rail. For SIFLOW FC070 Std.: 0 ... 60 °C (32 ... 140 °F) For SIFLOW FC070 Ex CT: -40 ... +60 °C (-40 ... +140 °F)		Within the limits according to "General requirements" with error criteria A in accordance with NE21
	Vertically mounted rail For SIFLOW FC070 Std.: 0 ... 45 °C (32 ... 113 °F) For SIFLOW FC070 Ex CT: -40 ... +45 °C (-40 ... +113 °F)	Programming tools	
Altitude	Operation: -1000 ... 2000 m (pressure 795 ... 1080 hPa)	SIMATIC S7	Configuration through backplane P-BUS, PLC program and WinCC flexible
Enclosure		SIMATIC PCS7	Configuration through backplane P-BUS and PLC/WinCC faceplates, certified driver
Material	Noryl, color: anthracite	SIMATIC PDM	Through Modbus port RS 232C and RS 485, certified driver
Rating	IP20/NEMA 2 according to IEC 60529		
Mechanical load	According to SIMATIC standards (S7-300 devices)		
Approvals Ex			
SIFLOW FC070 Standard	CE, C-UL, ATEX II 3G Ex nA IIC		
SIFLOW FC070 Ex CT	CE, C-UL, UL Haz.Loc., FM Class I, Div. 2 Groups A, B, C, D, ATEX II (1)G [Ex ia] IIC Ga / II 3G Ex nA IIC T4 Gc and IEC Ex Ex nA [ia] IIC T4		

SIMATIC S7-300

Function modules

SIFLOW FC070

Ordering data	Order No.
SIFLOW FC070 flow transmitter Remember to order 40-pin front plug connector.	7ME4120-2DH20-0EA0
40-pin front plug with screw contacts	6ES7392-1AM00-0AA0
40-pin plug with spring contacts	6ES7392-1BM01-0AA0
SIFLOW FC070 Ex flow transmitter Remember to order 20 pin front plug connector.	7ME4120-2DH21-0EA0
20-pin front plug with screw contacts	6ES7392-1AJ00-0AA0
20-pin plug with spring contacts	6ES7392-1BJ00-0AA0
Operating instructions for SITRANS F C SIFLOW FC070	
SIFLOW FC070 system manual • English • German	A5E00924779 A5E00924776
SIFLOW FC070 with S7 • English • German • French	A5E02254228 A5E02665536 A5E02591639
SIFLOW FC070 with PCS 7 • English	A5E03694109

This device is shipped with a Quick Start guide and a CD containing further SITRANS F literature.

All literature is also available for free at:

www.siemens.com/flowdocumentation

Accessories

Cable with multiplug

for connecting MASS 2100, FCS200 and FC300 sensors, 5 x 2 x 0.34 mm² twisted and screened in pairs.
Temperature range
-20 °C ... +110 °C (-4 °F ... +230 °F)

- 5 m (16.4 ft)
- 10 m (32.8 ft)
- 25 m (82 ft)
- 50 m (164 ft)
- 75 m (246 ft)
- 150 m (492 ft)

FDK:083H3015
FDK:083H3016
FDK:083H3017
FDK:083H3018
FDK:083H3054
FDK:083H3055

Cable without multiplug

for connecting MC2 sensors, 5 x 2 x 0.34 mm² twisted and screened in pairs.
Temperature range
-20 °C ... +110 °C (-4 °F ... +230 °F)

- 10 m (32.8 ft)
- 25 m (82 ft)
- 75 m (246 ft)
- 150 m (492 ft)

FDK:083H3001
FDK:083H3002
FDK:083H3003
FDK:083H3004

SIMATIC S7-300 rail

The mechanical mounting rack of the SIMATIC S7-300

- 160 mm (6.3")
- 482 mm (18.9")
- 530 mm (20.8")
- 830 mm (32.7")
- 2000 mm (78.7")

6ES7390-1AB60-0AA0
6ES7390-1AE80-0AA0
6ES7390-1AF30-0AA0
6ES7390-1AJ30-0AA0
6ES7390-1BC00-0AA0

SIFLOW FC070 Demo suitcase with MASS 2100 DI 1.5 sensor and SIMATIC HMI TP 177B touch panel

A5E01075465

SIMATIC S7-300, stabilized power supply PS307

6ES7307-1BA01-0AA0

Input: 120/230 V AC

Output: 24 V DC/2 A

SIMATIC S7-300

SIPLUS function modules

SIPLUS FM 350-1 counter modules

Overview



- Single-channel, intelligent counter module for simple counting tasks
- For direct connection of incremental encoders
- Comparison function with 2 definable comparison values
- Integrated digital outputs for output of the response on reaching the comparison value
- Operating modes:
 - Continuous counting
 - Single count
 - Periodic count
- Special functions:
 - Set counter
 - Latch counter
- Start/stop counter by gate function

Note:

SIPLUS extreme products are based on Siemens Industry standard products. The contents listed here were taken from the respective standard products. SIPLUS extreme specific information was added.

SIPLUS FM 350-1		
Order No.	6AG1 350-1AH03-2AE0	6AG1 350-1AH03-2AY0
Order No. based on	6ES7 350-1AH03-0AE0	6ES7 350-1AH03-0AE0
Ambient temperature range	-25 ... +60 °C	-25 ... +60 °C
Conformal coating	Coating of the printed circuit boards and the electronic components	
Technical data	The technical data of the standard product applies except for the ambient conditions.	
Conforms with standard for electronic equipment used on rolling stock (EN 50155).	No	Yes
Ambient conditions		
Relative humidity	100%, condensation/frost permissible. No commissioning if condensation present.	
Biologically active substances, compliance with EN 60721-3-3	Class 3B2 mold and fungal spores (excluding fauna). The supplied plug covers must remain in place over the unused interfaces during operation!	
Chemically active substances, compliance with EN 60721-3-3	Class 3C4 incl. salt spray in accordance with EN 60068-2-52 (degree of severity 3). The supplied plug covers must remain in place over the unused interfaces during operation!	
Mechanically active substances, compliance with EN 60721-3-3	Class 3S4 incl. sand, dust. The supplied plug covers must remain in place over the unused interfaces during operation!	
Air pressure (depending on the highest positive temperature range specified)	1 080 ... 795 hPa (-1 000 ... +2 000 m), see ambient temperature range 795 ... 658 hPa (+2 000 ... +3 500 m) derating 10 K 658 ... 540 hPa (+3 500 ... +5 000 m) derating 20 K	

For further technical documentation on SIPLUS, see:
www.siemens.com/siplus-extreme

Ordering data	Order No.
SIPLUS FM 350-1 counter module (extended temperature range and medial exposure) with 1 channel, max. 500 kHz; for incremental encoder without conformity to EN 50155	6AG1 350-1AH03-2AE0
Conformity to EN 50155	6AG1 350-1AH03-2AY0
Accessories	See SIMATIC S7-300 FM 350-1 counter module, page 5/110

SIMATIC S7-300

SIPLUS function modules

SIPLUS FM 350-2 counter modules

Overview



- 8-channel intelligent counter module for universal counting and measuring tasks
- For the direct connection of 24 V incremental encoders, directional encoders, initiators or NAMUR encoders
- Comparison function with predefined comparison values (number depending on operating mode)
- Integrated digital outputs for output of the response on reaching the comparison value
- Operating modes:
 - Continuous / single / periodic counting
 - Frequency and speed control
 - Period measurement
 - Dosing

Note:

SIPLUS extreme products are based on Siemens Industry standard products. The contents listed here were taken from the respective standard products. SIPLUS extreme specific information was added.

SIPLUS FM 350-2 counter module	
Order No.	6AG1 350-2AH01-4AE0
Order number based on	6ES7 350-2AH01-0AE0
Conformal coating	Coating of the printed circuit boards and the electronic components
Ambient temperature range	0... +60 °C
Ambient conditions	Suitable for extraordinary medial exposure (e.g. chlorine sulfur atmosphere)
Technical data	The technical data of the standard product applies except for the ambient conditions.
Ambient conditions	
Relative humidity	100%, condensation/frost permissible. No commissioning if condensation present.
Biologically active substances, compliance with EN 60721-3-3	Class 3B2 mold and fungal spores (excluding fauna). The supplied plug covers must remain in place over the unused interfaces during operation!
Chemically active substances, compliance with EN 60721-3-3	Class 3C4 incl. salt spray in accordance with EN 60068-2-52 (degree of severity 3). The supplied plug covers must remain in place over the unused interfaces during operation!
Mechanically active substances, compliance with EN 60721-3-3	Class 3S4 incl. sand, dust. The supplied plug covers must remain in place over the unused interfaces during operation!
Air pressure (depending on the highest positive temperature range specified)	1 080...795 hPa (-1 000 ... +2 000 m) See ambient temperature range 795...658 hPa (+2 000 ... +3 500m) derating 10 K 658 ... 540 hPa (+3 500 ... +5 000 m) derating 20 K

For technical documentation on SIPLUS, see:
www.siemens.com/siplus-extreme

Ordering data	Order No.
SIPLUS FM 350-2 counter module (medial exposure) With 8 channels, max. 20 kHz; for 24 V incremental encoders and NAMUR encoders; incl. configuration package and electronic documentation on CD	6AG1 350-2AH01-4AE0
Accessories	See SIMATIC FM 350-2 counter module, page 5/112

SIMATIC S7-300

SIPLUS function modules

SIPLUS SIWAREX U

Overview



SIPLUS SIWAREX U electronic weighing system

SIPLUS SIWAREX U is a flexible weighing module for all simple weighing and force measuring tasks. The compact module can be integrated into SIPLUS automation systems without any problems.

Note:

SIPLUS extreme products are based on Siemens Industry standard products. The contents listed here were taken from the respective standard products. SIPLUS extreme specific information was added.

SIPLUS SIWAREX U electronic weighing system

Order No.	6AG1 950-2AA01-4AA0
Order No. based on	7MH4 950-2AA01
Range of ambient temperature	0 ... +60 °C
Conformal coating	Coating of the printed circuit boards and the electronic components
Technical data	The technical data of the standard product applies except for the ambient conditions.

Ambient conditions

Relative humidity	100%, condensation/frost permissible. No commissioning if condensation present.
-------------------	---

For technical documentation on SIPLUS, see:
www.siemens.com/siplus-extreme

Ordering data

SIPLUS SIWAREX U

(medial exposure)
 Electronic weighing system for SIMATIC S7 and ET 200M, incl. bus connector

Accessories

Order No.

6AG1 950-2AA01-4AA0

See SIWAREX U, page 5/142

SIMATIC S7-300

SIPLUS function modules

SIPLUS DCF 77 radio clock module

Overview



This module can be used to synchronize the real-time clock of the SIMATIC S7-200, S7-300 and S7-400 automation systems with the official time of the DCF 77 time signal transmitter of the Physikalisch-Technische Bundesanstalt Braunschweig.

The time is received by means of a DCF receiver (antenna with electronics) which is connected via two digital inputs on the SIMATIC and SIPLUS together with a software driver included in the scope of delivery (function block FB). The function blocks are available on the Internet for downloading.

www.siemens.com/siplus - Support - Tools and Downloads!

Technical specifications

SIPLUS DCF 77 radio clock module

Radio frequency	77.5 Hz
Power supply	24 V DC (20.4 to 28.8 DC)
Power consumption, typ.	50 mA
Dimensions (W x H x D)	75 mm x 125 mm ¹⁾ x 75 mm

¹⁾ Additionally 25 mm (0.98 in) for heavy duty threaded joint and bending radius for cables

Ordering data

Order No.

SIPLUS DCF 77 radio clock module

6AG1 057-1AA03-0AA0

For synchronizing SIMATIC S7-200, S7-300 and S7-400 with the official time of the DCF 77 time signal transmitter of the Physikalisch-Technische Bundesanstalt Braunschweig

Overview



- Simulator module for program testing during commissioning and ongoing operation
- For the simulation of sensor signals using switches
- For display of signal conditions on the outputs using LED
- Simulation of
 - 16 inputs or
 - 16 outputs or
 - 8 inputs and 8 outputs
- Function can be directly adjusted on the module using a screwdriver

Technical specifications

6ES7 374-2XH01-0AA0	
Input current	
from backplane bus 5 V DC, max.	80 mA
Power losses	
Power loss, typ.	0.35 W
Digital inputs	
Number/binary inputs	16; Switch
Digital outputs	
Number/binary outputs	16; LEDs
Galvanic isolation	
Galvanic isolation digital inputs	
• between the channels and the backplane bus	No
Galvanic isolation digital outputs	
• between the channels and the backplane bus	No
Dimensions	
Width	40 mm
Height	125 mm
Depth	120 mm
Weight	
Weight, approx.	190 g

Ordering data

Ordering data	Order No.
SM 374 simulator module	6ES7 374-2XH01-0AA0
incl. bus connectors, labeling strips	
Bus connectors	6ES7 390-0AA00-0AA0
1 unit, spare part	
Labeling strips	6ES7 392-2XX00-0AA0
10 units (spare part)	
Label cover	6ES7 392-2XY00-0AA0
10 units (spare part)	
Labeling sheets for machine inscription	
for modules with 20-pin front connector, DIN A4, for printing with laser printer; 10 units	
petrol	6ES7 392-2AX00-0AA0
light-beige	6ES7 392-2BX00-0AA0
yellow	6ES7 392-2CX00-0AA0
red	6ES7 392-2DX00-0AA0

SIMATIC S7-300

Special modules

DM 370 dummy modules

Overview



- Dummy module for reserving slots for non-parameterized signal modules
- Structure and address allocation is retained when replaced with a signal module

Technical specifications

6ES7 370-0AA01-0AA0	
Input current	
from backplane bus 5 V DC, max.	5 mA
Power losses	
Power loss, max.	0.03 W
Digital inputs	
Number/binary inputs	0
Digital outputs	
Number/binary outputs	0
Dimensions	
Width	40 mm
Height	125 mm
Depth	120 mm
Weight	
Weight, approx.	180 g

Ordering data

Order No.

DM 370 dummy module	6ES7 370-0AA01-0AA0
incl. bus connectors, labeling strips	
Bus connectors	6ES7 390-0AA00-0AA0
1 unit, spare part	
Labeling strips	6ES7 392-2XX00-0AA0
10 units (spare part)	
Label cover	6ES7 392-2XY00-0AA0
10 units (spare part)	
Labeling sheets for machine inscription	
for modules with 20-pin front connector, DIN A4, for printing with laser printer; 10 units	
petrol	6ES7 392-2AX00-0AA0
light-beige	6ES7 392-2BX00-0AA0
yellow	6ES7 392-2CX00-0AA0
red	6ES7 392-2DX00-0AA0

Overview



- The economical complete solution for serial communication via point-to-point links.
- 3 versions with different transmission interfaces:
 - RS 232C (V.24)
 - 20 mA (TTY)
 - RS 422/RS 485 (X.27)
- Implemented protocols:
 - ASCII
 - 3964 (R) (not for RS 485)
 - Printer driver
- Simple parameterization via a parameterization tool integrated into STEP 7

Technical specifications

	6ES7 340-1AH02-0AE0	6ES7 340-1BH02-0AE0	6ES7 340-1CH02-0AE0
Supply voltage 24 V DC	No; Power supply via backplane bus 5V	No; Power supply via backplane bus 5V	No; Power supply via backplane bus 5V
Input current from backplane bus 5 V DC, max.	165 mA	190 mA	165 mA
Power losses Power loss, typ.	0.6 W	0.85 W	0.6 W
Power loss, max.	0.85 W	0.95 W	0.85 W
Interfaces Number of interfaces	1; Isolated	1; Isolated	1; Isolated
Interface physics, 20 mA (TTY)		Yes	
Interface physics, RS 232C (V.24)	Yes		
Interface physics, RS 422/RS 485 (X.27)			Yes
Transmission rate, max.	19.2 kbit/s	19.2 kbit/s	19.2 kbit/s
Transmission rates, min.	2.4 kbit/s	2.4 kbit/s	2.4 kbit/s
Point-to-point			
• Cable length, max.	15 m	1 000 m; (100 m active, 1000 m passive)	1 200 m
• supported printers	HP-Deskjet, HP-Laserjet, IBM-Proprinter, user-defined 9-pin sub D connector	HP-Deskjet, HP-Laserjet, IBM-Proprinter, user-defined 9-pin sub D socket	HP-Deskjet, HP-Laserjet, IBM-Proprinter, user-defined 15-pin sub D socket
• PtP			
• Integrated protocol driver			
- 3964 (R)	Yes	Yes	Yes
- ASCII	Yes	Yes	Yes
- RK512	No	No	No
- customer-specific drivers reloadable	No	No	No
• Telegram length, max.			
- 3964 (R)	1 024 byte	1 024 byte	1 024 byte
- ASCII	1 024 byte	1 024 byte	1 024 byte
• Transmission speed, 20 mA (TTY)			
- with 3964 (R) protocol, max.		19.2 kbit/s	
- with ASCII protocol, max.		9.6 kbit/s	
- with printer driver, max.,		9.6 kbit/s	
• Transmission speed, RS 422/485			
- with 3964 (R) protocol, max.			19.2 kbit/s
- with ASCII protocol, max.			9.6 kbit/s
- with printer driver, max.,			9.6 kbit/s
• Transmission speed, RS232			
- with 3964 (R) protocol, max.	19.2 kbit/s		
- with ASCII protocol, max.	9.6 kbit/s		
- with printer driver, max.,	9.6 kbit/s		

SIMATIC S7-300

Communication

CP 340

Technical specifications (continued)

	6ES7 340-1AH02-0AE0	6ES7 340-1BH02-0AE0	6ES7 340-1CH02-0AE0
Software			
Block			
• FB length in RAM, max.	2 700 byte; Data communication, sending and receiving	2 700 byte; Data communication, sending and receiving	2 700 byte; Data communication, sending and receiving
Connection method			
Power supply	Over backplane bus	Over backplane bus	Over backplane bus
Dimensions			
Width	40 mm	40 mm	40 mm
Height	125 mm	125 mm	125 mm
Depth	120 mm	120 mm	120 mm
Weight			
Weight, approx.	300 g	300 g	300 g

5

Ordering data

Ordering data	Order No.	Ordering data	Order No.
CP 340 communications module	6ES7 340-1AH02-0AE0	CP 340 communications module	6ES7 340-1CH02-0AE0
With one RS 232 C (V.24) interface		With one RS 422/485 (X.27) interface	
RS 232 connecting cable		RS 422/485 connecting cable	
For linking to SIMATIC S7		For linking to SIMATIC S7	
5 m	6ES7 902-1AB00-0AA0	5 m	6ES7 902-3AB00-0AA0
10 m	6ES7 902-1AC00-0AA0	10 m	6ES7 902-3AC00-0AA0
15 m	6ES7 902-1AD00-0AA0	50 m	6ES7 902-3AG00-0AA0
CP 340 communications module	6ES7 340-1BH02-0AE0		
With one 20 mA (TTY) interface			
20 mA (TTY) connecting cable			
For linking to SIMATIC S7			
5 m	6ES7 902-2AB00-0AA0		
10 m	6ES7 902-2AC00-0AA0		
50 m	6ES7 902-2AG00-0AA0		

Overview



- For quick, high-performance data exchange via point-to-point coupling
- 3 versions with different transmission physics:
 - RS 232C (V.24),
 - 20 mA (TTY),
 - RS 422/RS 485 (X.27)
- Implemented protocols: ASCII, 3964 (R), RK 512
- The following protocols can also be loaded: Modbus RTU
- Easy configuration using a parameterizing tool integrated in STEP 7

Technical specifications

Order No.	6ES7 341-1AH02-0AE0	6ES7 341-1BH02-0AE0	6ES7 341-1CH02-0AE0
Product-type designation	CP341 V2 RS232	CP341 V2 TTY	CP341 V2 RS422/485
Supply voltage 24 V DC	Yes	Yes	Yes
Input current from backplane bus 5 V DC, max.	70 mA	70 mA	70 mA
from supply voltage L+, max.	100 mA	100 mA	100 mA
Power losses Power loss, typ.	1.6 W	1.6 W	1.6 W
Power loss, max.	2.4 W	2.4 W	2.4 W
Interfaces Number of interfaces	1; Isolated	1; Isolated	1; Isolated
Interface physics, 20 mA (TTY)		Yes	
Interface physics, RS 232C (V.24)	Yes		
Interface physics, RS 422/RS 485 (X.27)			Yes
Transmission rate, max.	115.2 kbit/s	19.2 kbit/s	115.2 kbit/s
Transmission rates, min.	0.3 kbit/s	0.3 kbit/s	0.3 kbit/s
Point-to-point • Cable length, max.	15 m	1 000 m	1 200 m
• supported printers	Serial printers	Serial printers	Serial printers
• PtP	9-pin sub D connector	9-pin sub D socket	15-pin sub D socket
• Integrated protocol driver - 3964 (R)	Yes	Yes	Yes; not with RS 485
- ASCII	Yes	Yes	Yes
- RK512	Yes	Yes	Yes; not with RS 485
• Telegram length, max. - 3964 (R)	4 096 byte	4 096 byte	4 096 byte
- ASCII	4 096 byte	4 096 byte	4 096 byte
- RK 512	4 096 byte	4 096 byte	4 096 byte
• Transmission speed, 20 mA (TTY) - with 3964 (R) protocol, max.		19.2 kbit/s	
- with ASCII protocol, max.		19.2 kbit/s	
- with printer driver, max.,		19.2 kbit/s	
- with RK 512 protocol, max.		19.2 kbit/s	
• Transmission speed, RS 422/485 - with 3964 (R) protocol, max.			115.2 kbit/s
- with ASCII protocol, max.			115.2 kbit/s
- with printer driver, max.,			115.2 kbit/s
- with RK 512 protocol, max.			115.2 kbit/s
• Transmission speed, RS232 - with 3964 (R) protocol, max.	115.2 kbit/s		
- with ASCII protocol, max.	115.2 kbit/s		
- with printer driver, max.,	115.2 kbit/s		
- with RK 512 protocol, max.	115.2 kbit/s		

SIMATIC S7-300

Communication

CP 341

Technical specifications (continued)

Order No.	6ES7 341-1AH02-0AE0	6ES7 341-1BH02-0AE0	6ES7 341-1CH02-0AE0
Product-type designation	CP341 V2 RS232	CP341 V2 TTY	CP341 V2 RS422/485
Software Block • FB length in RAM, max.	6 100 byte; Data communication, sending and receiving	6 100 byte; Data communication, sending and receiving	6 100 byte; Data communication, sending and receiving
Connection method Power supply	3 screw-type terminals: L+, M, GND	3 screw-type terminals: L+, M, GND	3 screw-type terminals: L+, M, GND
Dimensions Width	40 mm	40 mm	40 mm
Height	125 mm	125 mm	125 mm
Depth	120 mm	120 mm	120 mm
Weight Weight, approx.	300 g	300 g	300 g

Ordering data

Ordering data	Order No.	Ordering data	Order No.
CP 341 communications module With one RS 232 C (V.24) interface	6ES7 341-1AH02-0AE0	CP 341 communications module With one RS 422/485 (X.27) interface	6ES7 341-1CH02-0AE0
RS 232 connecting cable For linking to SIMATIC S7		RS 422/485 connecting cable For linking to SIMATIC S7	
5 m	6ES7 902-1AB00-0AA0	5 m	6ES7 902-3AB00-0AA0
10 m	6ES7 902-1AC00-0AA0	10 m	6ES7 902-3AC00-0AA0
15 m	6ES7 902-1AD00-0AA0	50 m	6ES7 902-3AG00-0AA0
CP 341 communications module With one 20 mA (TTY) interface	6ES7 341-1BH02-0AE0	Loadable drivers for CP 341	
20 mA (TTY) connecting cable For linking to SIMATIC S7		Modbus master (RTU format)	
5 m	6ES7 902-2AB00-0AA0	• Single license	6ES7 870-1AA01-0YA0
10 m	6ES7 902-2AC00-0AA0	• Single license, without software or documentation	6ES7 870-1AA01-0YA1
50 m	6ES7 902-2AG00-0AA0	Modbus slave (RTU format)	
		• Single license	6ES7 870-1AB01-0YA0
		• Single license, without software or documentation	6ES7 870-1AB01-0YA1

Overview

- Drivers for Modbus protocol with RTU message format; communication as master or slave
- Downloadable onto CP 341 and CP 441-2 (6ES7 441-2AA04-0AE0)

Technical specifications

Parameterization software	Loadable drivers for CP 441-2 and CP 341
Type of license	Simple license, copy license
Target system	SIMATIC CP 341, SIMATIC CP 441-2

Technical specifications	Modbus Master
	<ul style="list-style-type: none"> • Modbus protocol with RTU format • Master/slave coupling: SIMATIC S7 is master • Function codes implemented: 01, 02, 03, 04, 05, 06, 07, 08, 11, 12, 15, 16 • No V.24 control and signal lines • CRC polynomial: $x^{16} + x^{15} + x^2 + 1$ • Interfaces: TTY (20 mA); V.24 (RS 232 C); X.27 (RS 422/485) 2-wire or 4-wire • Receive mailbox specified on BRCV • Character delay time 3.5 characters or multiple thereof • Broadcast message possible
Adjustable parameters	<ul style="list-style-type: none"> • Transmission rate 300 bit/s up to 76800 bit/s (TTY up to 19200 bit/s) • Character frame • With/without RS 485 operation for 2-wire connections • With/without modem operation (ignore smudge characters) • Response monitoring time 100 ms to 25.5 s in steps of 100 ms • Factor for the character delay time 1-10 • Default setting of receive line when using the X.27 interface module

Technical specifications	Modbus slave
	<ul style="list-style-type: none"> • Modbus protocol with RTU format • Master/slave coupling: SIMATIC S7 is slave • Function codes implemented: 01, 02, 03, 04, 05, 06, 08, 15, 16 • No V.24 control and signal line • CRC polynomial: $x^{16} + x^{15} + x^2 + 1$ • Interfaces: TTY (20 mA), V.24 (RS 232C), X.27 (RS 422/485) 2-wire or 4-wire • Communications FB 180, instance DB 180 (use of a multi-instance) • Conversion of the Modbus data address to S7 data areas. Data areas which can be processed: DB, bit memories, outputs, inputs, timers, counters • Character delay time 3.5 characters or multiple thereof
Adjustable parameters	<ul style="list-style-type: none"> • Transmission rate 300 bit/s up to 76800 bit/s (TTY up to 19200 bit/s) • Character frame • Slave address of CP (1 to 255) • With/without RS 485 operation for 2-wire connection • With/without modem operation (ignore smudge characters) • Factor for the character delay time 1-10 • Number of work DB (for FB processing) • Enabling of memory areas for writing by the master • Default setting of receive line when using the X.27 interface module • Conversion of Modbus addresses to S7 data areas

SIMATIC S7-300

Communication

Loadable drivers for CP 441-2 and CP 341

Ordering data	Order No.		Order No.
<p>Modbus Master V3.1</p> <p>Task: Communication via Modbus protocol with RTU format, SIMATIC S7 as master</p> <p>Requirement: CP 341 or CP 441-2; STEP 7 V4.02 and higher</p> <p>Delivery package: Driver program/documentation, English, German, French</p> <p>Single license</p> <p>Single license, without software and documentation</p>	<p>6ES7 870-1AA01-0YA0</p> <p>6ES7 870-1AA01-0YA1</p>	<p>SIMATIC Manual Collection</p> <p>Electronic manuals on DVD, multilingual: LOGO!, SIMADYN, SIMATIC bus components, SIMATIC C7, SIMATIC distributed I/O, SIMATIC HMI, SIMATIC Sensors, SIMATIC NET, SIMATIC PC Based Automation, SIMATIC PCS 7, SIMATIC PG/PC, SIMATIC S7, SIMATIC Software, SIMATIC TDC</p>	<p>6ES7 998-8XC01-8YE0</p>
<p>Modbus Slave V3.1</p> <p>Task: Communication via Modbus protocol with RTU format, SIMATIC S7 as slave</p> <p>Requirement: CP 341 or CP 441-2; STEP 7 V4.02 and higher</p> <p>Delivery package: Driver program/documentation, English, German, French</p> <p>Single license</p> <p>Single license, without software and documentation</p>	<p>6ES7 870-1AB01-0YA0</p> <p>6ES7 870-1AB01-0YA1</p>	<p>SIMATIC Manual Collection update service for 1 year</p> <p>Current "Manual Collection" DVD and the three subsequent updates</p>	<p>6ES7 998-8XC01-8YE2</p>

5

Overview



The CP 343-2P is the AS-Interface master for the SIMATIC S7-300 programmable controller and the ET 200M distributed I/O station.

The CP 343-2 is the basic version of the module.

The CP 343-2P / CP 343-2 has the following characteristics:

- Connection of up to 62 AS-Interface slaves
- Integrated analog value transmission (all analog profiles)
- Supports all AS-Interface master functions according to the AS-Interface Specification V3.0
- Status displays of operating states and indication of the readiness for operation of connected slaves by means of LEDs in the front panel
- Fault indications (e. g. AS-Interface voltage fault, configuration fault) by means of LEDs in the front panel
- Compact enclosure in the design of the SIMATIC S7-300
- Suitable for AS-i Power24V (from product version 2 / Firmware-Version 3.1) for Standard AS-i with 30 V voltage.
- With CP 343-2P additionally: Supports the configuration of the AS-Interface-network with STEP 7 V5.2 and higher

Design

The CP 343-2P / CP 343-2 is connected like an I/O module to the S7-300. It has:

- Two terminal connections for direct connection of the AS-Interface cable
- LEDs in the front panel for indicating the operating state and the readiness for operation of all connected and activated slaves
- Pushbuttons for switching over the master operating state and for adopting the existing ACTUAL configuration of the AS-i slave as the DESIRED configuration

Function

The CP 343-2P / CP 343-2 supports all specified functions of the AS-Interface Specification V3.0.

The CP 343-2P / CP 343-2 occupies 16 bytes each in the I/O address area of the SIMATIC S7-300. The digital I/O data of the standard slaves and A slaves are saved in this area. The digital I/O data of the B slaves and the analog I/O data can be accessed with the S7 system functions for read/write data record.

If required, master calls can be performed with the command interface, e. g. read/write parameters, read/write configuration.

More information can be found on the Internet under

<http://support.automation.siemens.com/WW/view/en/51678777>

Configuration

All connected AS-Interface slaves are configured at the press of a button. No further configuration of the CP is required.

With CP 343-2P additionally

The CP 343-2P also supports configuring of the AS-Interface network with STEP 7 V5.2 and higher. Specifying the AS-i configuration in HW-Config facilitates the setting of slave parameters and documentation of the plant. Uploading the ACTUAL configuration of an already configured AS-Interface network is also supported. The saved configuration cannot be overwritten at the press of a button and is therefore tamper-proof.

SIMATIC S7-300

Communication

CP 343-2 P, CP 343-2

Technical specifications

Order No.	6GK7 343-2AH11-0XA0 6GK7 343-2AH01-0XA0
Product type designation	CP 343-2P CP 343-2
Interfaces	
Version of electrical connection of the AS-Interface	S7-300 front connector with terminal connection
Supply voltage	
Supply voltage from backplane bus	5 V
Current consumption	
Current consumed	
• from backplane bus at 5 V DC typical	200 mA
• from AS-Interface shaped cables, max.	100 mA
Suitable for AS-i Power 24 V	Yes, from product version 2 / Firmware version 3.1
Effective power loss	
Effective power loss	2 W
Permitted ambient conditions	
Ambient temperature	
• during operation	0 ... 60 °C
• during storage	-40 ... +70 °C
• during transport	-40 ... +70 °C
Maximum relative humidity at 25 °C during operation	95%
Design, dimensions and weight	
Module format	S7-300 design
Width	40 mm
Height	125 mm
Depth	120 mm
Net weight	190 g
Number of slots required	1
Standards and specifications	
Version of the AS-Interface specification	V 3.0
Bus cycle time of the AS-Interface	
• with 31 slaves	5 ms
• with 62 slaves	10 ms
Power data	
Data volume	
• of the address area of the inputs	16 byte
• of the address area of the outputs	16 byte
Number of modules / for each CPU / maximum	typically 4 per rack, limited by current consumption from backplane bus
Configuration	
Configuration software included in scope of delivery of STEP 7 V5.x NCM S7 for Industrial Ethernet	Yes

Ordering data

Order No.

CP 343-2P communications processor	6GK7 343-2AH11-0XA0
for the connection of SIMATIC S7-300 and ET 200M to AS-Interface; configuration of the AS-i network by means of SET-key or via STEP 7 (V5.2 or higher); without front connector	
CP 343-2 communications processor	6GK7 343-2AH01-0XA0
For connecting SIMATIC S7-300 and ET 200M to the AS-Interface ; configuration of the AS-i network by means of SET-key; without front connector	
Front connector, 20-pin	6ES7 392-1AJ00-0AA0
• With screw terminals	
Front connector, 20-pin	6ES7 392-1BJ00-0AA0
• With spring-type terminals	
Front connector, 20-pin	6ES7 392-1CJ00-0AA0
• With FastConnect	
Manuals	6GK1 975-1AA00-3AA0
Manuals available in the Internet at http://support.automation.siemens.com/WWW/view/en/14310380/133300	

5

Overview



DP-M	DP-S	FMS	PG/OP	S7/S5	
●	●		●	●	

- PROFIBUS DP master or slave with electrical interface for connecting the SIMATIC S7-300 to PROFIBUS at up to 12 Mbit/s (including 45.45 Kbit/s)
- Communication services:
 - PROFIBUS DP
 - PG/OP communication (OP multiplexing)
 - S7 communication (client, server)
 - Open communication (SEND/RECEIVE)
- Easy configuration and programming over PROFIBUS
- Cross-network programming device communication through S7 routing
- Modules can be replaced without the need for a PG

5

Technical specifications

Order No.	6GK7 342-5DA03-0XE0
Product-type designation	CP 342-5
Transmission rate	
Transmission rate at interface 1 in accordance with PROFIBUS	9.6 kbit/s ... 12 Mbit/s
Interfaces	
Number of electrical connections	
• at interface 1 in accordance with PROFIBUS	1
• for power supply	1
Design of electrical connection	
• at interface 1 in accordance with PROFIBUS	9-pin Sub-D socket (RS485)
• for power supply	
Supply voltage, current consumption, power loss	
Type of voltage of supply voltage	DC
Supply voltage	
• 1 from backplane bus	5 V
• external	24 V
Relative positive tolerance at 24 V with DC	20 %
Relative negative tolerance at 24 V with DC	15 %
Consumed current	
• from backplane bus at 5 V for DC Typical	0.15 A
• from external supply voltage at 24 V with DC	
- typical	0.25 A
- maximum	-
Resistive loss	6.75 W

Order No.	6GK7 342-5DA03-0XE0
Product-type designation	CP 342-5
Permitted ambient conditions	
Ambient temperature	
• during operating	0 ... 60 °C
• during storage	-40 ... +70 °C
• during transport	-40 ... +70 °C
• Comment	-
Relative humidity at 25 °C without condensation during operating maximum	95 %
Protection class IP	IP20
Design, dimensions and weight	
Module format	
Width	40 mm
Height	125 mm
Depth	120 mm
Net weight	0.3 kg
Product properties, functions, components general	
Number of modules	
• per CPU maximum	4
• note	-

SIMATIC S7-300

Communication

CP 342-5

Technical specifications (continued)

Order No.	6GK7 342-5DA03-0XE0
Product-type designation	CP 342-5
Performance data	
<u>Performance data open communication</u>	
Number of possible connections for open communication by means of SEND/RECEIVE blocks maximum	16
Data volume as user data per connection for open communication by means of SEND/RECEIVE blocks maximum	240 byte
<u>Performance data PROFIBUS DP</u>	
Service as DP master DPV0	Yes
Number of DP slaves on DP master usable	124
Amount of data	
• of the address area of the inputs as DP master overall	2 160 byte
• of the address area of the outputs as DP master overall	2 160 byte
• of the address area of the inputs per DP slave	244 byte
• of the address area of the outputs per DP slave	244 byte
• of the address area of the diagnostic data per DP slave	240 byte
Service as DP slave	
• DPV0	Yes
• DPV1	-
Amount of data	
• of the address area of the inputs as DP slave overall	240 byte
• of the address area of the outputs as DP slave overall	240 byte

Order No.	6GK7 342-5DA03-0XE0
Product-type designation	CP 342-5
<u>Performance data S7 communication</u>	
Number of possible connections for S7 communication	16
• maximum	-
• with PG connections maximum	-
• with PG/OP connections maximum	-
• note	-
<u>Performance data multi-protocol mode</u>	
Number of active connections with multi-protocol mode	
• without DP maximum	32
• with DP maximum	28
Product functions management, configuration	
Configuration software required	STEP 7 V5.1 SP2 and higher or STEP 7 V11.0 and higher

Ordering data

Ordering data	Order No.
CP 342-5 communications processor	6GK7 342-5DA03-0XE0
Communications processor for electrical connection of SIMATIC S7-300 to PROFIBUS at up to 12 Mbit/s, with electronic manual on CD-ROM	
PROFIBUS FastConnect bus connector RS485	
With 90° cable outlet; insulation displacement technology, max. transfer rate 12 Mbit/s (1 unit)	
• Without PG interface	6ES7 972-0BA52-0XA0
• With PG interface	6ES7 972-0BB52-0XA0

Ordering data	Order No.
PROFIBUS bus connector IP20	
With connection to PPI, MPI, PROFIBUS	
• Without PG interface	6ES7 972-0BA12-0XA0
• With PG interface	6ES7 972-0BB12-0XA0
PROFIBUS bus terminal 12M	6GK1 500-0AA10
Bus terminal for connection of PROFIBUS nodes at up to 12 Mbit/s with connecting cable	
SIMATIC S7-300 DM 370	6ES7 370-0AA01-0AA0
Dummy module; used for module replacement	

Overview



DP-M	DP-S	FMS	PG/OP	S7/S5	
●	●		●	●	

- PROFIBUS DP master or slave with optical interface for connecting the SIMATIC S7-300 to PROFIBUS at up to 12 Mbit/s (including 45.45 Kbit/s)
- Direct connection to the optical PROFIBUS network over the integrated fiber-optic interface for plastic and PCF fiber-optic cables
- Communication services:
 - PROFIBUS DP
 - PG/OP communication (OP multiplexing)
 - S7 communication (client, server)
 - Open communication (SEND/RECEIVE)
- Easy configuration and programming over PROFIBUS
- Cross-network programming device communication through S7 routing
- Modules can be replaced without the need for a PG

5

Technical specifications

Order No.	6GK7 342-5DF00-0XE0
Product-type designation	CP 342-5 FO
Transmission rate	
Transmission rate at interface 1 in accordance with PROFIBUS	9,6 kbit/s ... 12 Mbit/s
Interfaces	
Number of optical connections at interface 1 in accordance with PROFIBUS	2
Number of electrical connections for power supply	1
Design of optical connection at interface 1 in accordance with PROFIBUS	Duplex socket
Design of the electrical connection for power supply	
Supply voltage, current consumption, power loss	
Type of voltage of supply voltage	DC
Supply voltage	
• 1 from backplane bus	5 V
• external	24 V
Relative positive tolerance at 24 V with DC	20 %
Relative negative tolerance at 24 V with DC	15 %
Consumed current	
• from backplane bus at 5 V for DC Typical	0.15 A
• from external supply voltage at 24 V with DC	
- typical	0,25 A
- maximum	-
Resistive loss	6 W

Order No.	6GK7 342-5DF00-0XE0
Product-type designation	CP 342-5 FO
Permitted ambient conditions	
Ambient temperature	
• during operating	0 ... 60 °C
• during storage	-40 ... +70 °C
• during transport	-40 ... +70 °C
• Comment	-
Relative humidity at 25 °C without condensation during operating maximum	95 %
Protection class IP	IP20
Design, dimensions and weight	
Module format	
Width	40 mm
Height	125 mm
Depth	120 mm
Net weight	0,3 kg
Product properties, functions, components general	
Number of modules	
• per CPU maximum	4
• note	-
Cable length	
• with PCF cable maximum	300 m
• with POF cable maximum	50 m

SIMATIC S7-300

Communication

CP 342-5 FO

Technical specifications (continued)

Order No.	6GK7 342-5DF00-0XE0	Order No.	6GK7 342-5DF00-0XE0
Product-type designation	CP 342-5 FO	Product-type designation	CP 342-5 FO
Performance data		Performance data	
<u>Performance data open communication</u>		<u>Performance data S7 communication</u>	
Number of possible connections for open communication by means of SEND/RECEIVE blocks maximum	16	Number of possible connections for S7 communication	16
Data volume as user data per connection for open communication by means of SEND/RECEIVE blocks maximum	240 byte	<ul style="list-style-type: none"> • maximum • with PG connections maximum • with PG/OP connections maximum • note 	-
<u>Performance data PROFIBUS DP</u>		<u>Performance data multi-protocol mode</u>	
Service as DP master DPV0	Yes	Number of active connections with multi-protocol mode	
Number of DP slaves on DP master usable	124	<ul style="list-style-type: none"> • without DP maximum • with DP maximum 	32 28
Amount of data		Product functions management, configuration	
<ul style="list-style-type: none"> • of the address area of the inputs as DP master overall • of the address area of the outputs as DP master overall • of the address area of the inputs per DP slave • of the address area of the outputs per DP slave • of the address area of the diagnostic data per DP slave 	2 160 byte 2 160 byte 244 byte 244 byte 240 byte	Configuration software required	STEP 7 V5.1 SP2 and higher or STEP 7 V11.0 and higher
Service as DP slave			
<ul style="list-style-type: none"> • DPV0 • DPV1 	Yes -		
Amount of data			
<ul style="list-style-type: none"> • of the address area of the inputs as DP slave overall • of the address area of the outputs as DP slave overall 	240 byte 240 byte		

Ordering data	Order No.	Order No.
CP 342-5 FO communications processor	6GK7 342-5DF00-0XE0	6GK1 905-6PA10
Communication processor for optical connection of SIMATIC S7-300 to PROFIBUS to 12 Mbit/s with electronic manual on CD-ROM		PROFIBUS Plastic Fiber Optic, Stripping Tool Set
		Tools for removing the outer sheath or core sheath of Plastic Fiber Optic cables
PROFIBUS Plastic Fiber Optic, Simplex Connector/Polishing Set	6GK1 901-0FB00-0AA0	Plug-in adapter
100 simplex connectors and 5 polishing sets for assembling PROFIBUS plastic fiber optic cables for the optical PROFIBUS DP		For assembling the plastic Simplex connector in combination with CP 342-5 FO, IM 467 FO, IM 153-2 FO and IM 151 FO
		50 units

Overview



Connection of SIMATIC S7-300 to PROFIBUS at up to 12 Mbit/s (including 45.45 Kbit/s)

- Communication services:
 - PG/OP communication
 - S7 communication
 - Open communication (SEND/RECEIVE)
 - PROFIBUS FMS
- Easy configuration and programming over PROFIBUS
- Can be easily integrated into the S7-300 system
- Cross-network programming device communication through S7 routing
- Modules can be replaced without the need for a PG

DP-M	DP-S	FMS	PG/OP	S7/S5	
		●	●	●	

Technical specifications

Order No.	6GK7 343-5FA01-0XE0
Product-type designation	CP 343-5
Transmission rate	
Transmission rate at interface 1 in accordance with PROFIBUS	9.6 kbit/s ... 12 Mbit/s
Interfaces	
Number of electrical connections	
• at interface 1 in accordance with PROFIBUS	1
• for power supply	1
Design of electrical connection	
• at interface 1 in accordance with PROFIBUS	9-pin Sub-D socket (RS485)
• for power supply	
Supply voltage, current consumption, power loss	
Type of voltage of supply voltage	DC
Supply voltage	
• 1 from backplane bus	5 V
• external	24 V
Relative positive tolerance at 24 V with DC	20 %
Relative negative tolerance at 24 V with DC	15 %
Consumed current	
• from backplane bus at 5 V for DC Typical	0.15 A
• from external supply voltage at 24 V with DC	
- typical	0,25 A
- maximum	-
Resistive loss	5 W

Order No.	6GK7 343-5FA01-0XE0
Product-type designation	CP 343-5
Permitted ambient conditions	
Ambient temperature	
• during operating	0 ... 60 °C
• during storage	-40 ... +70 °C
• during transport	-40 ... +70 °C
• Comment	-
Relative humidity at 25 °C without condensation during operating maximum	95 %
Protection class IP	IP20
Design, dimensions and weight	
Module format	
Width	40 mm
Height	125 mm
Depth	120 mm
Net weight	0,3 kg
Product properties, functions, components general	
Number of modules	
• per CPU maximum	4
• note	-

SIMATIC S7-300

Communication

CP 343-5

Technical specifications (continued)

Order No.	6GK7 343-5FA01-0XE0
Product-type designation	CP 343-5
Performance data	
<u>Performance data open communication</u>	
Number of possible connections for open communication by means of SEND/RECEIVE blocks maximum	16
Data volume as user data per connection for open communication by means of SEND/RECEIVE blocks maximum	240 byte
<u>Performance data FMS functions</u>	
Number of possible connections for FMS connection maximum	16
Amount of data of the variables	
• for READ job maximum	237 byte
• for WRITE and REPORT job maximum	233 byte
Number of variables	
• Configurable from server to FMS partner	256
• Loadable from server to FMS partner	256
<u>Performance data S7 communication</u>	
Number of possible connections for S7 communication	
• maximum	16
• with PG connections maximum	-
• with PG/OP connections maximum	-
• note	-
<u>Performance data multi-protocol mode</u>	
Number of active connections with multiprotocol mode	48
Product functions management, configuration	
Configuration software required	

Ordering data

Order No.

CP 343-5 communications processor	6GK7 343-5FA01-0XE0
Communications processor for connection of S7-300 to PROFIBUS, FMS, open communication, PG/OP and S7 communication; with electronic manual on CD-ROM	
PROFIBUS FastConnect bus connector RS485	
With 90° cable outlet; insulation displacement technology, max. transmission rate 12 Mbit/s (1 unit)	
• Without PG interface	6ES7 972-0BA52-0XA0
• With PG interface	6ES7 972-0BB52-0XA0
PROFIBUS bus connector IP20	
With connection to PPI, MPI, PROFIBUS	
• Without PG interface	6ES7 972-0BA12-0XA0
• With PG interface	6ES7 972-0BB12-0XA0
PROFIBUS bus terminal 12M	6GK1 500-0AA10
Bus terminal for connection of PROFIBUS nodes at up to 12 Mbit/s with connecting cable	
SIMATIC S7-300 DM 370	6ES7 370-0AA01-0AA0
Dummy module; used for module replacement	

5

Overview



Communications processor for connecting a SIMATIC S7-300 to Industrial Ethernet networks, also as PROFINET IO Device.

The CP supports:

- PG/OP communication
- S7 communication
- Open communication (SEND/RECEIVE)
- PROFINET communication

ISO	TCP/UDP	PN	MRP	IT	IP-R	PG/OP	S7/S5
	●	●	●			●	●

Technical specifications

Order No.	6GK7 343-1CX10-0XE0
Product-type designation	CP 343-1 Lean
Transmission rate	
Transfer rate at the interface 1	10 ... 100 Mbit/s
Interfaces	
Number of electrical connections	
• at interface 1 in accordance with Industrial Ethernet	2
• for power supply	1
Design of electrical connection	
• at interface 1 in accordance with Industrial Ethernet	RJ45 port
• for power supply	
Supply voltage, current consumption, power loss	
Type of voltage of supply voltage	DC
Supply voltage	
• 1 from backplane bus	5 V
• external	24 V
Relative positive tolerance at 24 V with DC	20 %
Relative negative tolerance at 24 V with DC	15 %
Consumed current	
• from backplane bus at 5 V for DC Typical	0.2 A
• from external supply voltage at 24 V with DC	
- typical	0.16 A
- maximum	0.2 A
Resistive loss	5.8 W

Order No.	6GK7 343-1CX10-0XE0
Product-type designation	CP 343-1 Lean
Permitted ambient conditions	
Ambient temperature	
• during operating	0 ... 60 °C
• during storage	-40 ... +70 °C
• during transport	-40 ... +70 °C
• Comment	-
Relative humidity at 25 °C without condensation during operating maximum	95 %
Protection class IP	IP20
Design, dimensions and weight	
Module format	
Width	40 mm
Height	125 mm
Depth	120 mm
Net weight	0,22 kg
Product properties, functions, components general	
Number of modules	
• per CPU maximum	-
• note	-

SIMATIC S7-300

Communication

CP 343-1 Lean

Technical specifications (continued)

Order No.	6GK7 343-1CX10-0XE0
Product-type designation	CP 343-1 Lean
Performance data	
<u>Performance data open communication</u>	
Number of possible connections for open communication by means of SEND/RECEIVE blocks maximum	8
Data volume	
• as user data per ISO on TCP connection for open communication by means of SEND/RECEIVE blocks maximum	8 Kibyte
• as user data per TCP connection for open communication by means of SEND/RECEIVE blocks maximum	8 Kibyte
• as user data per UDP connection for open IE communication by means of SEND/RECEIVE blocks maximum	2 Kibyte
Number of Multicast stations	8
<u>Performance data S7 communication</u>	
Number of possible connections for S7 communication	
• maximum	4
• with PG connections maximum	-
• with PG/OP connections maximum	-
• note	-
Service of SIMATIC communication as server	Yes
<u>Performance data multi-protocol mode</u>	
Number of active connections with multiprotocol mode	12
<u>Performance data PROFINET communication as PN IO-Device</u>	
Product function PROFINET IO device	Yes
Amount of data	
• as useful data for input variables as PROFINET IO device maximum	512 byte
• as useful data for input variables as PROFINET IO device maximum	512 byte
• as useful data for input variables for each sub-module under PROFINET IO device	240 byte
• as useful data for input variables for each sub-module under PROFINET IO device	240 byte
• as useful data for the consistency area for each sub-module	240 byte
Number of submodules per PROFINET IO-Device	32

Order No.	6GK7 343-1CX10-0XE0
Product-type designation	CP 343-1 Lean
Product functions management, configuration	
Product function MIB support	Yes
Protocol is supported	
• SNMP v1	Yes
• DCP	Yes
• LLDP	Yes
Configuration software required	
Identification & maintenance	
• I&M0 - device-specific information	Yes
• I&M1 - plant identification/location name	Yes
Product functions Diagnosis	
Product function Web-based diagnostics	Yes
Product functions switch	
Product feature switch	Yes
Product function	
• switch-managed	No
• Configuration with STEP 7	Yes
Product functions Redundancy	
Product function	
• Ring redundancy	Yes
• MRP redundancy protocol	Yes
Product functions Security	
Product function	
• switchoff of non-required services	Yes
• blocking of communication via physical ports	Yes
Product functions Time	
Product function	
• SICLOCK support	Yes
• pass on time synchronization	Yes
Protocol is supported NTP	Yes

Ordering data	Order No.	Order No.
CP 343-1 Lean communications processor For connecting SIMATIC S7-300 to Industrial Ethernet through TCP/IP and UDP, Multicast, S7 communication, open communication (SEND/RECEIVE), FETCH/WRITE, PROFINET IO Device, MRP, integrated 2-port switch ERTEC, comprehensive diagnostics facilities, module replacement without PG, SNMP, initial commissioning over LAN; with electronic manual on CD-ROM	6GK7 343-1CX10-0XE0	SOFTNET S7 for Industrial Ethernet Software for S7 and open communication, including OPC server, PG/OP communication and NCM PC, runtime software, software and electronic manual on CD-ROM, license key on a USB stick, Class A SOFTNET-IE S7 V8.2 For 32/64-bit Windows 7 Professional/Ultimate; for 64-bit: Windows 2008 Server R2; German/English Up to 64 connections • Single License for one installation
IE FC TP Standard Cable GP 2x2 4-core, shielded TP installation cable for connection to IE FC RJ45 outlet / IE FC RJ45 plug; PROFINET-compliant; with UL approval; sold by the meter max. length 1000 m, minimum order 20 m	6XV1 840-2AH10	6GK1 704-1CW08-2AA0 SOFTNET-S7 Edition 2008 (V7.1) for Industrial Ethernet for 32-bit Windows XP Professional SP2/3; Windows 2003 Server R2, SP2; Windows Vista Business/Ultimate SP1; Windows 2008 Server; German/English Up to 64 connections • Single License for one installation
CSM 377 Compact Switch Module Unmanaged switch for connection of a SIMATIC S7-300-CPU, ET 200M and as many as three further nodes to Industrial Ethernet operating at 10/100 Mbit/s; 4 x RJ45 ports; external 24 V DC power supply, LED diagnostics, S7-300 module including electronic Manual on CD-ROM	6GK7 377-1AA00-0AA0	6GK1 704-1CW71-3AA0 Software Update Service For 1 year with automatic extension; requirement: current software version Upgrade • From Edition 2006 to Edition 2008 or V8.1 • From V6.0, V6.1, V6.2 or V6.3 to Edition 2008 or V8.1
IE FC RJ45 Plug 145 RJ45 plug connector for Industrial Ethernet with a rugged metal housing and integrated insulation displacement contacts for connecting Industrial Ethernet FC installation cables; with 145° cable outlet; <ul style="list-style-type: none"> • 1 pack = 1 unit • 1 pack = 10 units • 1 pack = 50 units 	6GK1 901-1BB30-0AA0 6GK1 901-1BB30-0AB0 6GK1 901-1BB30-0AE0	6GK1 704-1CW00-3AE0 6GK1 704-1CW00-3AE1 SOFTNET-IE S7 Lean Edition V8.2 Up to eight connections • Single License for one installation
IE FC Stripping Tool Preadjusted stripping tool for fast stripping of the Industrial Ethernet FC cables	6GK1 901-1GA00	6GK1 704-1LW08-2AA0 SOFTNET-S7 Lean Edition 2008 (V7.1) for Industrial Ethernet Up to eight connections • Single License for one installation Software Update Service For 1 year with automatic extension; requirement: current software version Upgrade • From Edition 2006 to Edition 2008 or V8.1 • From V6.0, V6.1, V6.2 or V6.3 to Edition 2008 or V8.1
		6GK1 704-1LW71-3AA0 6GK1 704-1LW00-3AL0 6GK1 704-1LW00-3AE0 6GK1 704-1LW00-3AE1

SIMATIC S7-300

Communication

CP 343-1

Overview



Communications processor for connecting a SIMATIC S7-300/SINUMERIK 840D powerline to Industrial Ethernet networks, also as PROFINET IO Controller or IO Device.

The CP supports:

- PG/OP communication
- S7 communication
- Open communication (SEND/RECEIVE)
- PROFINET communication

5

ISO	TCP/UDP	PN	MRP	IT	IP-R	PG/OP	S7/S5
●	●	●	●			●	●

Technical specifications

Order No.	6GK7 343-1EX30-0XE0
Product-type designation	CP 343-1
Transmission rate	
Transfer rate at the interface 1	10 ... 100 Mbit/s
Interfaces	
Number of electrical connections	
• at interface 1 in accordance with Industrial Ethernet	2
• for power supply	1
Design of electrical connection	
• at interface 1 in accordance with Industrial Ethernet	RJ45 port
• for power supply	
Supply voltage, current consumption, power loss	
Type of voltage of supply voltage	DC
Supply voltage	
• 1 from backplane bus	5 V
• external	24 V
Relative positive tolerance at 24 V with DC	20 %
Relative negative tolerance at 24 V with DC	15 %
Consumed current	
• from backplane bus at 5 V for DC Typical	0,2 A
• from external supply voltage at 24 V with DC	
- typical	0.16 A
- maximum	0.2 A
Resistive loss	5.8 W

Order No.	6GK7 343-1EX30-0XE0
Product-type designation	CP 343-1
Permitted ambient conditions	
Ambient temperature	
• during operating	0 ... 60 °C
• during storage	-40 ... +70 °C
• during transport	-40 ... +70 °C
• Comment	-
Relative humidity at 25 °C without condensation during operating maximum	95 %
Protection class IP	IP20
Design, dimensions and weight	
Module format	
Width	40 mm
Height	125 mm
Depth	120 mm
Net weight	0.22 kg
Product properties, functions, components general	
Number of modules	
• per CPU maximum	-
• note	-

Technical specifications (continued)

Order No.	6GK7 343-1EX30-0XE0
Product-type designation	CP 343-1
Performance data	
<u>Performance data open communication</u>	
Number of possible connections for open communication by means of SEND/RECEIVE blocks maximum	16
Data volume	
• as user data per ISO connection for open communication by means of SEND/RECEIVE blocks maximum	8 Kibyte
• as user data per ISO on TCP connection for open communication by means of SEND/RECEIVE blocks maximum	8 Kibyte
• as user data per TCP connection for open communication by means of SEND/RECEIVE blocks maximum	8 Kibyte
• as user data per UDP connection for open IE communication by means of SEND/RECEIVE blocks maximum	2 Kibyte
Number of Multicast stations	16
<u>Performance data S7 communication</u>	
Number of possible connections for S7 communication	16
• maximum	-
• with PG connections maximum	-
• with PG/OP connections maximum	-
• note	-
<u>Performance data multi-protocol mode</u>	
Number of active connections with multiprotocol mode	32
<u>Performance data PROFINET communication as PN IO-Controller</u>	
Number of PN IO-Devices on PROFINET IO-Controller usable total	32
Number of external PN IO lines with PROFINET per rack	1
Data volume	
• as useful data for input variables as PROFINET IO controller maximum	1 Kibyte
• as useful data for output variables with PROFINET IO controller maximum	1 Kibyte
• as useful data for input variables per PN IO device with PROFINET IO controller maximum	1 433 byte
• as useful data for output variables per PN IO device with PROFINET IO controller maximum	1 433 byte
• as user data for input variable per PN IO device per submodule as PROFINET IO controller maximum	240 byte
• as user data for output variables per PN IO device per submodule as PROFINET IO controller maximum	240 byte

Order No.	6GK7 343-1EX30-0XE0
Product-type designation	CP 343-1
<u>Performance data PROFINET communication as PN IO-Device</u>	
Product function PROFINET IO device	Yes
Amount of data	
• as useful data for input variables as PROFINET IO device maximum	512 byte
• as useful data for input variables as PROFINET IO device maximum	512 byte
• as useful data for input variables for each sub-module under PROFINET IO device	240 byte
• as useful data for input variables for each sub-module under PROFINET IO device	240 byte
• as useful data for the consistency area for each sub-module	240 byte
Number of submodules per PROFINET IO-Device	32
Product functions management, configuration	
Product function MIB support	Yes
Protocol is supported	
• SNMP v1	Yes
• DCP	Yes
• LLDP	Yes
Configuration software required	
Identification & maintenance	
• I&M0 - device-specific information	Yes
• I&M1 - plant identification/location name	Yes
Product functions Diagnosis	
Product function Web-based diagnostics	Yes
Product functions Switch	
Product feature switch	Yes
Product function	
• switch-managed	No
• Configuration with STEP 7	Yes
Product functions Redundancy	
Product function	
• Ring redundancy	Yes
• Redundancy manager	No
• MRP redundancy protocol	Yes
Product functions Security	
Product function	
• ACL - IP-based	Yes
• switchoff of non-required services	Yes
• blocking of communication via physical ports	Yes
• log file for unauthorized access	No
Product functions Time	
Product function	
• SICLOCK support	Yes
• pass on time synchronization	Yes
Protocol is supported NTP	Yes

SIMATIC S7-300

Communication

CP 343-1

Ordering data	Order No.	Order No.
CP 343-1 communications processor For connection of SIMATIC S7-300 to Industrial Ethernet over ISO and TCP/IP; PROFINET IO Controller or PROFINET IO Device, MRP, integrated 2-port switch ERTEC; S7 communication, open communication (SEND/RECEIVE), FETCH/WRITE, with and without RFC 1006, multicast, DHCP, CPU clock synchronization via SIMATIC procedure and NTP, diagnostics, SNMP, access protection through IP access list, initialization over LAN 10/100 Mbit/s; with electronic manual on DVD	6GK7 343-1EX30-0XE0	SOFTNET S7 for Industrial Ethernet Software for S7 and open communication, including OPC server, PG/OP communication and NCM PC, runtime software, software and electronic manual on CD-ROM, license key on a USB stick, Class A SOFTNET-IE S7 V8.2 For 32/64-bit Windows 7 Professional/Ultimate; for 64-bit: Windows 2008 Server R2; German/English Up to 64 connections • Single License for one installation
IE FC TP Standard Cable GP 2x2 4-core, shielded TP installation cable for connection to IE FC RJ45 outlet / IE FC RJ45 plug; PROFINET-compliant; with UL approval; sold by the meter max. length 1000 m, minimum order 20 m	6XV1 840-2AH10	SOFTNET-S7 Edition 2008 (V7.1) for Industrial Ethernet For 32-bit Windows XP Professional SP2/3; Windows 2003 Server R2, SP2; Windows Vista Business/Ultimate SP1; Windows 2008 Server; German/English Up to 64 connections • Single License for one installation
C-PLUG Removable media for easy device replacement upon failure, for receiving configuration or projects and application data, may be used in SIMATIC NET products with C-PLUG slot	6GK1 900-0AB00	Software Update Service For 1 year with automatic extension; requirement: current software version
Industrial Ethernet Switch SCALANCE X204-2 Industrial Ethernet switches with integral SNMP access, online diagnostics, copper cable diagnostics and PROFINET diagnostics for configuring line, star and ring topologies; four 10/100 Mbit/s RJ45 ports and two fiber-optic cable ports	6GK5 204-2BB10-2AA3	Upgrade • From Edition 2006 to Edition 2008 or V8.1 • From V6.0, V6.1, V6.2 or V6.3 to Edition 2008 or V8.1
CSM 377 Compact Switch Module Unmanaged switch for connection of a SIMATIC S7-300-CPU, ET 200M and as many as three further nodes to Industrial Ethernet operating at 10/100 Mbit/s; 4 x RJ45 ports; external 24 V DC power supply, LED diagnostics, S7-300 module including electronic Manual on CD-ROM	6GK7 377-1AA00-0AA0	SOFTNET-IE S7 Lean Edition V8.2 Up to eight connections • Single License for one installation
IE FC RJ45 Plug 145 RJ45 plug connector for Industrial Ethernet with a rugged metal housing and integrated insulation displacement contacts for connecting Industrial Ethernet FC installation cables; 145° cable outlet • 1 pack = 1 unit • 1 pack = 10 units • 1 pack = 50 units	6GK1 901-1BB30-0AA0 6GK1 901-1BB30-0AB0 6GK1 901-1BB30-0AE0	SOFTNET-S7 Lean Edition 2008 (V7.1) for Industrial Ethernet Up to eight connections • Single License for one installation
IE FC Stripping Tool Preadjusted stripping tool for fast stripping of the Industrial Ethernet FC cables	6GK1 901-1GA00	Software Update Service For 1 year with automatic extension; requirement: current software version Upgrade • From Edition 2006 to Edition 2008 or V8.1 • From V6.0, V6.1, V6.2 or V6.3 to Edition 2008 or V8.1

5

Overview



Communications processor for connecting the SIMATIC S7-300/ SINUMERIK 840D powerline to Industrial Ethernet networks, also as PROFINET IO controller and IO device.

The CP supports:

- PG/OP communication
- S7 communication
- Open communication (SEND/RECEIVE)
- PROFINET communication
- IT communication
- Security functions, firewall and VPN

In addition, the CP 343-1 Advanced provides e-mail functions and allows users to create their own Web pages - ideal support for maintenance and quality assurance. The Internet functions such as FTP even allow connection to the most diverse PC-based systems. This CP is therefore the bridge between the field level and the management level for the S7-300. The CP 343-1 Advanced connects seamlessly to the security structures of the office and IT world.

ISO	TCP/UDP	PN	MRP	IT	IP-R	PG/OP	S7/S5
●	●	●	●	●	●	●	●

Technical specifications

Order No.	6GK7 343-1GX31-0XE0	6GK7 343-1GX30-0XE0
Product-type designation	CP 343-1 Advanced	CP 343-1 Advanced
Transmission rate		
Transfer rate		
• at the interface 1	10 ... 1 000 Mbit/s	10 ... 1 000 Mbit/s
• at the interface 2	10 ... 100 Mbit/s	10 ... 100 Mbit/s
Interfaces		
Number of electrical connections		
• at interface 1 in accordance with Industrial Ethernet	1	1
• at interface 2 in accordance with Industrial Ethernet	2	2
• for power supply	1	1
Design of electrical connection		
• at interface 1 in accordance with Industrial Ethernet	RJ45 port	RJ45 port
• at interface 2 in accordance with Industrial Ethernet	RJ45 port	RJ45 port
• for power supply		
design of the removable storage C-PLUG	Yes	Yes
Supply voltage, current consumption, power loss		
Type of voltage of supply voltage	DC	DC
Supply voltage		
• 1 from backplane bus	5 V	5 V
• external	24 V	24 V
Relative positive tolerance at 24 V with DC	20 %	20 %
Relative negative tolerance at 24 V with DC	15 %	15 %
Consumed current		
• from backplane bus at 5 V for DC Typical	0.14 A	0.14 A
• from external supply voltage at 24 V with DC		
- typical	0.48 A	0.48 A
- maximum	0.62 A	0.62 A
Resistive loss	14.7 W	14.7 W
Permitted ambient conditions		
Ambient temperature		
• during operating	--	--
• during storage	-40 ... +70 °C	-40 ... +70 °C
• during transport	-40 ... +70 °C	-40 ... +70 °C
• Comment	-	-
Relative humidity at 25 °C without condensation during operating maximum	95 %	95 %
Protection class IP	IP20	IP20

SIMATIC S7-300

Communication

CP 343-1 Advanced

Technical specifications (continued)

Order No.	6GK7 343-1GX31-0XE0	6GK7 343-1GX30-0XE0
Product-type designation	CP 343-1 Advanced	CP 343-1 Advanced
Design, dimensions and weight		
Module format		
Width	80 mm	80 mm
Height	125 mm	125 mm
Depth	120 mm	120 mm
Net weight	0.8 kg	0.6 kg
Product properties, functions, components general		
Number of modules		
• per CPU maximum	-	-
• note	-	-
Performance data		
<u>Performance data open communication</u>		
Number of possible connections for open communication by means of SEND/RECEIVE blocks maximum	16	16
Data volume		
• as user data per ISO connection for open communication by means of SEND/RECEIVE blocks maximum	8 Kibyte	8 Kibyte
• as user data per ISO on TCP connection for open communication by means of SEND/RECEIVE blocks maximum	8 Kibyte	8 Kibyte
• as user data per TCP connection for open communication by means of SEND/RECEIVE blocks maximum	8 Kibyte	8 Kibyte
• as user data per UDP connection for open IE communication by means of SEND/RECEIVE blocks maximum	2 Kibyte	2 Kibyte
Number of Multicast stations	16	16
<u>Performance data S7 communication</u>		
Number of possible connections for S7 communication		
• maximum	16	16
• with PG connections maximum	-	-
• with PG/OP connections maximum	-	-
• note	-	-
<u>Performance data multi-protocol mode</u>		
Number of active connections with multiprotocol mode	48	48
<u>Performance data IT functions</u>		
Number of possible connections		
• as client by means of FTP maximum	10	10
• as server		
- by means of FTP maximum	2	2
- by means of HTTP maximum	4	4
• as e-mail client maximum	1	1
Amount of data as useful data for e-mail maximum	8 Kibyte	8 Kibyte
Storage capacity of user memory		
• as flash memory file system	28 Mibyte	28 Mibyte
• as RAM	30 Mibyte	30 Mibyte
Number of possible write cycles flash memory cells	100 000	100 000

Technical specifications (continued)

Order No.	6GK7 343-1GX31-0XE0	6GK7 343-1GX30-0XE0
Product-type designation	CP 343-1 Advanced	CP 343-1 Advanced
<u>Performance data PROFINET communication as PN IO-Controller</u>		
Number of PN IO-Devices on PROFINET IO-Controller usable total	128	128
Number of PN IO IRT-Devices on PROFINET IO-Controller usable	128	32
Number of external PN IO lines with PROFINET per rack	1	1
Data volume		
• as useful data for input variables as PROFINET IO controller maximum	4 Kibyte	4 Kibyte
• as useful data for output variables with PROFINET IO controller maximum	4 Kibyte	4 Kibyte
• as useful data for input variables per PN IO device with PROFINET IO controller maximum	1 433 byte	1 433 byte
• as useful data for output variables per PN IO device with PROFINET IO controller maximum	1 433 byte	1 433 byte
• as user data for input variable per PN IO device per submodule as PROFINET IO controller maximum	240 byte	240 byte
• as user data for output variables per PN IO device per submodule as PROFINET IO controller maximum	240 byte	240 byte
<u>Performance data PROFINET communication as PN IO-Device</u>		
Product function PROFINET IO device	Yes	Yes
Amount of data		
• as useful data for input variables as PROFINET IO device maximum	1 024 byte	1 024 byte
• as useful data for input variables as PROFINET IO device maximum	1 024 byte	1 024 byte
• as useful data for input variables for each sub-module under PROFINET IO device	240 byte	240 byte
• as useful data for input variables for each sub-module under PROFINET IO device	240 byte	240 byte
• as useful data for the consistency area for each sub-module	240 byte	240 byte
Number of submodules per PROFINET IO-Device	32	32
<u>Performance data PROFINET CBA</u>		
Number of remote connection partners with PROFINET CBA	64	64
Number of connections with PROFINET CBA total	1 000	1 000
Amount of data		
• as useful data for digital inputs with PROFINET CBA maximum	8 192 byte	8 Kibyte
• as useful data for digital outputs in the case of PROFINET CBA max.	8 192 byte	8 Kibyte
• as useful data for arrays and data types		
- in the case of acyclic transmission with PROFINET CBA maximum	8 192 byte	8 Kibyte
- in the case of cyclic transmission with PROFINET CBA maximum	250 byte	250 byte
- in the case of local interconnection with PROFINET CBA maximum	2 400 byte	2 400 byte
<u>Performance data PROFINET CBA remote connection with acyclic transmission</u>		
Updating time of the remote interconnections in the case of acyclic transmission with PROFINET CBA	0.1 s	100 ms
Number of remote connections to input variables with acyclic transmission with PROFINET CBA maximum	128	128
Number of remote connections to output variables with acyclic transmission with PROFINET CBA maximum	128	128
Amount of data		
• as useful data for remote interconnections with input variables in the case of acyclic transmission with PROFINET CBA	8 Kibyte	8 Kibyte
• as useful data for remote interconnections with output variables in the case of acyclic transmission with PROFINET CBA	8 Kibyte	8 Kibyte

SIMATIC S7-300

Communication

CP 343-1 Advanced

Technical specifications (continued)

Order No.	6GK7 343-1GX31-0XE0	6GK7 343-1GX30-0XE0
Product-type designation	CP 343-1 Advanced	CP 343-1 Advanced
Performance data PROFINET CBA remote connection with cyclic transmission		
Updating time of the remote interconnections in the case of acyclic transmission with PROFINET CBA	8 ms	8 ms
Number of remote connections to input variables with cyclic transmission with PROFINET CBA maximum	200	200
Number of remote connections to output variables with cyclic transmission with PROFINET CBA maximum	200	200
Amount of data		
• as useful data for remote interconnections with input variables in the case of cyclic transmission with PROFINET CBA max.	2 000 byte	2 000 byte
• as useful data for remote interconnections with output variables in the case of cyclic transmission with PROFINET CBA maximum	2 000 byte	2 000 byte
Performance data PROFINET CBA HMI variables via PROFINET acyclic		
Number of connectable HMI stations for HMI variables with acyclic transmission with PROFINET CBA	3	3
Updating time of the HMI variables in the case of acyclic transmission with PROFINET CBA	500 ms	500 ms
Number of HMI variables with acyclic transmission with PROFINET CBA maximum	200	200
Amount of data as useful data for HMI variables in the case of acyclic transmission with PROFINET CBA maximum	8 Kibyte	8 Kibyte
Performance data PROFINET CBA device-internal connections		
Number of internal connections with PROFINET CBA maximum	256	256
Data volume of internal connections with PROFINET CBA maximum	2 400 byte	2 400 byte
Performance data PROFINET CBA connections to constants		
Number of connections to constants with PROFINET CBA maximum	200	200
Amount of data as useful data for interconnections with constants in the case of PROFINET CBA maximum	4 096 byte	4 096 byte
Performance data PROFINET CBA PROFIBUS proxy functionality		
Product function with PROFINET CBA PROFIBUS proxy functionality	No	No
Product functions management, configuration		
Product function MIB support	Yes	Yes
Protocol is supported		
• SNMP v1	Yes	Yes
• DCP	Yes	Yes
• LLDP	Yes	Yes
Configuration software		
• required	STEP 7 V5.5 SP2 HF1 or higher or STEP 7 V12.0 or higher	STEP 7 V5.4 SP4 or higher or STEP 7 V11.0 or higher
• for PROFINET CBA required	SIMATIC iMap V3.0 SP4 and higher	SIMATIC iMap V3.0 SP1 and higher
Identification & maintenance		
• I&M0 - device-specific information	Yes	Yes
• I&M1 - plant identification/location name	Yes	Yes
Product functions Diagnosis		
Product function Web-based diagnostics	Yes	Yes
Product functions switch		
Product feature switch	Yes	Yes
Product function		
• switch-managed	No	No
• for IRT PROFINET IO switch	Yes	Yes
• Configuration with STEP 7	Yes	Yes

Technical specifications (continued)

Order No.	6GK7 343-1GX31-0XE0	6GK7 343-1GX30-0XE0
Product-type designation	CP 343-1 Advanced	CP 343-1 Advanced
Product functions Redundancy		
Product function		
• Ring redundancy	Yes	Yes
• Redundancy manager	Yes	Yes
• MRP redundancy protocol	Yes	Yes
Product functions Security		
Design of the firewall	stateful inspection	-
Product function with VPN connection	IPSec	-
Type of encryption algorithms with VPN connection	AES-256, AES-192, AES-128, 3DES-168, DES-56	-
Type of authentication procedure with VPN connection	Preshared key (PSK), X.509v3 certificates	-
Type of hashing algorithms with VPN connection	MD5, SHA-1	-
Number of possible connections for VPN connection	32	-
Product function		
• password protection for Web applications	Yes	Yes
• ACL - IP-based	Yes	Yes
• ACL - IP-based for PLC/routing	Yes	Yes
• switchoff of non-required services	Yes	Yes
• blocking of communication via physical ports	Yes	Yes
• log file for unauthorized access	No	No
Product functions Time		
Product function		
• SICLOCK support	Yes	Yes
• pass on time synchronization	Yes	Yes
Protocol is supported NTP	Yes	Yes

Ordering data

CP 343-1 Advanced communications processor

For connecting the SIMATIC S7-300 CPU to Industrial Ethernet;
 1 x 10/100/1000 Mbit/s;
 2 x 10/100 Mbit/s (IE switch);
 RJ45 ports; TCP; UDP; ISO;
 PROFINET IO controller and device,
 S7 communication (client + server);
 open communication (SEND/
 RECEIVE); S7 routing; IP configura-
 tion via DHCP/block; extended Web
 diagnostics; time synchronization;
 IP Access Control List; IP routing;
 FTP; e-mail; PROFINET CBA;
 C-PLUG

- With Security (firewall + VPN) and PROFINET (controller + device)
- Without security (firewall + VPN) and PROFINET (controller + device)

Order No.

6GK7 343-1GX31-0XE0

6GK7 343-1GX30-0XE0

SOFTNET S7 for Industrial Ethernet

Software for S7 and open communi-
 cation, including OPC server,
 PG/OP communication and
 NCM PC, runtime software, software
 and electronic manual on CD-ROM,
 license key on a USB stick, Class A

SOFTNET-IE S7 V8.2

For 32/64-bit Windows 7
 Professional/Ultimate;
 for 64-bit: Windows 2008 Server R2;
 German/English

up to 64 connections

- Single license for one installation

Order No.

6GK1 704-1CW08-2AA0

SIMATIC S7-300

Communication

CP 343-1 Advanced

5

Ordering data	Order No.	Order No.
SOFTNET-S7 Edition 2008 (V7.1) for Industrial Ethernet for 32-bit Windows XP Professional SP2/3; Windows 2003 Server R2, SP2; Windows Vista Business/Ultimate SP1; Windows 2008 Server; German/English up to 64 connections • Single license for one installation Software Update Service For one year with automatic extension; requirement: Current software version Upgrade • From Edition 2006 to Edition 2008 or V8.1 • From V6.0, V6.1, V6.2 or V6.3 to Edition 2008 or V8.1	6GK1 704-1CW71-3AA0 6GK1 704-1CW00-3AL0	IE FC RJ45 Plug 180 RJ45 plug-in connector for Industrial Ethernet with a rugged metal enclosure and integrated insulation displacement contacts for connecting Industrial Ethernet FC installation cables; with a 180° cable outlet; for network components and CPs/CPU with Industrial Ethernet interface • 1 pack = 1 unit • 1 pack = 10 units • 1 pack = 50 units 6GK1 901-1BB10-2AA0 6GK1 901-1BB10-2AB0 6GK1 901-1BB10-2AE0
SOFTNET-IE S7 Lean Edition V8.2 Up to eight connections • Single license for one installation	6GK1 704-1LW08-2AA0	IE FC RJ45 Plug 4 x 2 RJ45 plug-in connector for Industrial Ethernet (10/100/1000 Mbit/s) with a rugged metal enclosure and integrated insulation displacement contacts for connecting Industrial Ethernet FC installation cables; 180° cable outlet; for network components and CPs/CPU with Industrial Ethernet interface • 1 pack = 1 unit • 1 pack = 10 units • 1 pack = 50 units 6GK1 901-1BB11-2AA0 6GK1 901-1BB11-2AB0 6GK1 901-1BB11-2AE0
SOFTNET-S7 Lean Edition 2008 (V7.1) for Industrial Ethernet Up to eight connections • Single license for one installation Software Update Service For one year with automatic extension; requirement: Current software version Upgrade • From Edition 2006 to Edition 2008 or V8.1 • From V6.0, V6.1, V6.2 or V6.3 to Edition 2008 or V8.1	6GK1 704-1LW71-3AA0 6GK1 704-1LW00-3AL0	IE FC Stripping Tool Preadjusted stripping tool for fast stripping of Industrial Ethernet FC cables 6GK1 901-1GA00
IE FC TP standard cable GP 2 x 2 (type A) 4-wire, shielded TP installation cable for connection to IE FC RJ45 outlet / IE FC RJ45 plug; PROFINET-compliant; with UL approval; sold by the meter; max. quantity 1000 m, minimum order 20 m	6XV1 840-2AH10	Compact Switch Module CSM 377 6GK7 377-1AA00-0AA0 Unmanaged switch for connection of a SIMATIC S7-300-CPU, ET 200M and up to three further nodes to Industrial Ethernet operating at 10/100 Mbit/s; 4 x RJ45 ports; external 24 V DC power supply, LED diagnostics, S7-300 module including electronic manual on CD-ROM
IE FC TP standard cable GP 4 x 2 8-core, shielded TP installation cable for connection to IE FC RJ45 Modular Outlet for universal application; with UL approval; sold by the meter; max quantity 1000 m, minimum order 20 m • AWG22, for connection to IE FC RJ45 Modular Outlet • AWG24, for connection to IE FC RJ45 Plug 4 x 2	6XV1 870-2E 6XV1 878-2A	Industrial Ethernet Switch SCALANCE X308-2 6GK5 308-2FL00-2AA3 2 x 1000 Mbit/s multimode fiber-optic ports (SC sockets), 1 x 10/100/1000 Mbit/s RJ45 port, 7 x 10/100 Mbit/s RJ45 ports; for glass fiber-optic cable (multimode) up to max. 750 m
		SIMATIC iMap V3.0 for configuring PROFINET CBA, Requirement: Windows 2000 Prof. with Service Pack 4 or later or Windows XP Prof. with Service Pack 1 or later or Windows 2003 Server with Service Pack 1 or later; on PG or PC with Pentium processor, min. 1 GHz; STEP 7 V5.3 or later with Service Pack 3, PN OPC Server V6.3 or later Available in: German, English, with electronic documentation • Single license • Software Update Service • Upgrade to V3.0, single license 6ES7 820-0CC04-0YA5 6ES7 820-0CC01-0YX2 6ES7 820-0CC04-0YE5

Overview



The CP 343-1 ERPC (Enterprise Connect) communications processor for connecting a SIMATIC S7-300 to Industrial Ethernet networks.

The CP supports:

- PG/OP communication
- S7 communication
- Open communication (SEND/RECEIVE)
- ERPC communication

Connection of the SIMATIC S7-300 to various database systems for vertical integration is supported by means of a firmware expansion from ILS-Technology to be ordered separately.

ERPC	TCP/UDP	PN	MRP	IT	IP-R	PG/OP	S7/S5
●	●					●	●

Technical specifications

Order No.	6GK7 343-1FX00-0XE0
Product-type designation	CP 343-1 ERPC
Transmission rate	
Transfer rate at the interface 1	10 ... 1 000 Mbit/s
Interfaces	
Number of electrical connections	
• at interface 1 in accordance with Industrial Ethernet	1
• for power supply	1
Design of electrical connection	
• at interface 1 in accordance with Industrial Ethernet	RJ45 port
• for power supply	
design of the removable storage C-PLUG	Yes
Supply voltage, current consumption, power loss	
Type of voltage of supply voltage	DC
Supply voltage	
• 1 from backplane bus	5 V
• external	24 V
Relative positive tolerance at 24 V with DC	20 %
Relative negative tolerance at 24 V with DC	15 %
Consumed current	
• from backplane bus at 5 V for DC Typical	0,3 A
• from external supply voltage at 24 V with DC	
- typical	0.16 A
- maximum	0.6 A
Resistive loss	14.7 W

Order No.	6GK7 343-1FX00-0XE0
Product-type designation	CP 343-1 ERPC
Permitted ambient conditions	
Ambient temperature	
• during operating	--
• during storage	-40 ... +70 °C
• during transport	-40 ... +70 °C
• Comment	-
Relative humidity at 25 °C without condensation during operating maximum	95 %
Protection class IP	IP20
Design, dimensions and weight	
Module format	
Width	80 mm
Height	125 mm
Depth	120 mm
Net weight	0,8 kg
Product properties, functions, components general	
Number of modules	
• per CPU maximum	-
• note	-

SIMATIC S7-300

Communication

CP 343-1 ERPC

Technical specifications (continued)

Order No.	6GK7 343-1FX00-0XE0
Product-type designation	CP 343-1 ERPC
Performance data	
<u>Performance data open communication</u>	
Number of possible connections for open communication by means of SEND/RECEIVE blocks maximum	8
Data volume	
• as user data per ISO on TCP connection for open communication by means of SEND/RECEIVE blocks maximum	8 Kibyte
• as user data per TCP connection for open communication by means of SEND/RECEIVE blocks maximum	8 Kibyte
• as user data per UDP connection for open IE communication by means of SEND/RECEIVE blocks maximum	2 Kibyte
Number of Multicast stations	8
<u>Performance data S7 communication</u>	
Number of possible connections for S7 communication	8
• maximum	8
• with PG connections maximum	-
• with PG/OP connections maximum	-
• note	also 2 PG/OP connections and 1 diagnostics connection
<u>Performance data multi-protocol mode</u>	
Number of active connections with multiprotocol mode	32
<u>Performance data ERPC functions</u>	
Number of possible connections for communication with ERP or MES stations maximum	8
Number of possible logical triggers per CP maximum	8
Number of configurable ERPC symbols for database access	
• per CPU maximum	2 000
• per logical trigger maximum	255
Data volume as user data and header information per logical trigger	8 Kibyte

Order No.	6GK7 343-1FX00-0XE0
Product-type designation	CP 343-1 ERPC
Product functions management, configuration	
Product function MIB support	Yes
Protocol is supported	
• SNMP v1	Yes
• DCP	Yes
• LLDP	Yes
Configuration software required	STEP 7 V5.4 SP5 or higher plus HSP or STEP 7 V11.0 or higher
Identification & maintenance	
• I&M0 - device-specific information	Yes
• I&M1 - plant identification/location name	Yes
Product functions Diagnosis	
Product function Web-based diagnostics	Yes
Product functions Redundancy	
Product function	
• Ring redundancy	No
• MRP redundancy protocol	-
Product functions Security	
Product function	
• ACL - IP-based	Yes
• switchoff of non-required services	Yes
• blocking of communication via physical ports	Yes
• log file for unauthorized access	No
Product functions Time	
Product function	
• SICLOCK support	Yes
• pass on time synchronization	Yes
Protocol is supported NTP	Yes

Ordering data	Order No.		Order No.
<p>CP 343-1 ERPC communications processor (Enterprise Connect)</p> <p>For the connection of SIMATIC S7-300 to Industrial Ethernet and for the support of the database connection of the SIMATIC S7-300 to various databases; TCP/UDP, S7 communication, open communication (SEND/RECEIVE), with and without RFC 1006, multicast, web server, setting of CPU's clock using SIMATIC procedures and NTP, access protection via IP access list, SNMP, DHCP, initialization over LAN 10/100/1000 Mbit/s; with electronic manual on DVD, C-PLUG included in scope of delivery</p> <p>SOFTNET S7 for Industrial Ethernet</p> <p>Software for S7 and open communication, including OPC server, PG/OP communication and NCM PC, runtime software, software and electronic manual on CD-ROM, license key on a USB stick, Class A</p> <p>SOFTNET-IE S7 V8.2</p> <p>For 32/64-bit Windows 7 Professional/Ultimate; for 64-bit: Windows 2008 Server R2; German/English</p> <p>up to 64 connections</p> <ul style="list-style-type: none"> • Single License for one installation 	6GK7 343-1FX00-0XE0		
<p>SOFTNET-S7 Edition 2008 (V7.1) for Industrial Ethernet</p> <p>for 32-bit Windows XP Professional SP2/3; Windows 2003 Server R2, SP2; Windows Vista Business/Ultimate SP1; Windows 2008 Server; German/English</p> <p>up to 64 connections</p> <ul style="list-style-type: none"> • Single License for one installation 			
<p>Software Update Service</p> <p>For 1 year with automatic extension; requirement: current software version</p> <p>Upgrade</p> <ul style="list-style-type: none"> • From Edition 2006 to Edition 2008 or V8.1 • From V6.0, V6.1, V6.2 or V6.3 to Edition 2008 or V8.1 			
<p>SOFTNET-IE S7 Lean Edition V8.2</p> <p>Up to eight connections</p> <ul style="list-style-type: none"> • Single License for one installation 			6GK1 704-1LW08-2AA0
<p>SOFTNET-S7 Lean Edition 2008 (V7.1) for Industrial Ethernet</p> <p>Up to eight connections</p> <ul style="list-style-type: none"> • Single License for one installation 			6GK1 704-1LW71-3AA0
<p>Software Update Service</p> <p>For 1 year with automatic extension; requirement: current software version</p>			6GK1 704-1LW00-3AL0
<p>Upgrade</p> <ul style="list-style-type: none"> • From Edition 2006 to Edition 2008 or V8.1 • From V6.0, V6.1, V6.2 or V6.3 to Edition 2008 or V8.1 			6GK1 704-1LW00-3AE0 6GK1 704-1LW00-3AE1
<p>SCALANCE X308-2 Industrial Ethernet Switch</p> <p>2 x 1000 Mbit/s multimode fiber-optic cable ports (SC sockets), 1 x 10/100/1000 Mbit/s RJ45 port, 7 x 10/100 Mbit/s RJ45 ports; for glass fiber-optic cable (multimode) up to max. 750 m</p>			6GK5 308-2FL00-2AA3
<p>IE FC TP Standard Cable GP 4 x 2</p> <p>8-core, shielded TP installation cable for universal use; with UL approval; sold by the meter max. length 1000 m; minimum order quantity 20 m</p> <ul style="list-style-type: none"> • AWG 22, for connection to IE FC RJ45 Modular Outlet • AWG 24, for connection to IE FC RJ45 Plug 4 x 2 			6XV1 870-2E 6XV1 878-2A
<p>IE FC RJ45 Plug 4 x 2</p> <p>RJ45 plug connector for Industrial Ethernet (10/100/1000 Mbit/s) with a rugged metal housing and integrated insulation displacement contacts for connecting Industrial Ethernet FC installation cables; 180° cable outlet; for network components and CPs/CPU's with Industrial Ethernet interface</p> <ul style="list-style-type: none"> • 1 pack = 1 unit • 1 pack = 10 units • 1 pack = 50 units 			6GK1 901-1BB11-2AA0 6GK1 901-1BB11-2AB0 6GK1 901-1BB11-2AE0
<p>IE FC Stripping Tool</p> <p>Preadjusted stripping tool for fast stripping of the Industrial Ethernet FC cables</p>			6GK1 901-1GA00

More information

You can obtain further information on the software "deviceWISE embedded Edition for SIMATIC S7" from:

ILS Technology LLC;
5300 Broken Sound Blvd.
Suite 150
Boca Raton, FL, USA, 33487
Phone.: +1-561-982-9898 x124
Fax.: +1-561-982-8638
E-mail: devicewise@ilstechnology.com
Internet: www.ilstechnology.com/erpc

SIMATIC S7-300

Communication

CSM 377 unmanaged

Overview



- Unmanaged switch for the connection of a SIMATIC S7-300 with integral PROFINET interface or with an Industrial Ethernet CP or ET 200M to an Industrial Ethernet in an electrical linear, tree or star structure
- As many as three additional nodes can be connected
- As an unmanaged switch, the CSM 377 is used for integrating small machines into existing automation networks or for the standalone operation of the machines
- Simple, space-saving attachment to S7-300 mounting rail due to design as single-width module in S7-300 format
- Low-cost solution for implementing small, local Ethernet networks
- Rugged, industry-standard node connections with PROFINET-compliant RJ45 connectors that latch onto the enclosure to offer additional strain and bending relief

Technical specifications

Order No.	6GK7 377-1AA00-0AA0
Product-type designation	CSM 377
Transmission rate	
Transfer rate 1	10 Mbit/s
Transfer rate 2	100 Mbit/s
Interfaces	
Number of electrical/optical connections for network components or terminal equipment maximum	4
Number of electrical connections	
• for network components and terminal equipment	4
• for alarm contact	-
• for power supply	1
Design of electrical connection	
• for network components and terminal equipment	RJ45 port
• for signaling contact	-
• for power supply	2-pole terminal block
Supply voltage, current consumption, power loss	
Type of voltage of supply voltage	DC
Supply voltage external	24 V
• minimum	19.2 V
• maximum	28.8 V
Product component fusing at power supply input	Yes
Type of fusing at input for supply voltage	0.5 A / 60 V
Consumed current maximum	0.07 A
Active power loss at 24 V for DC	1.6 W
Permitted ambient conditions	
Ambient temperature	
• during operating	0 ... 60 °C
• during storage	-40 ... +70 °C
• during transport	-40 ... +70 °C
Relative humidity at 25 °C without condensation during operating maximum	95 %
Protection class IP	IP20

Order No.	6GK7 377-1AA00-0AA0
Product-type designation	CSM 377
Design, dimensions and weight	
Design	SIMATIC S7-300 device design
Width	40 mm
Height	125 mm
Depth	118 mm
Net weight	0.2 kg
Type of mounting	
• 35 mm DIN rail mounting	No
• wall mounting	No
• S7-300 rail mounting	Yes
Type of mounting	-
Product properties, functions, components general	
Cascading in cases of star structuring	-
Product functions management, configuration	
Product function switch-managed	No
Standards, specifications, approvals	
Standard	
• for EMC from FM	FM3611: Class 1, Division 2, Group A, B, C, D / T..., CL.1, Zone 2, GP, IIC, T, Ta
• for hazardous zone	EN 60079-15, II 3 G Ex nA II T..., KEMA 06 ATEX 0021 X
• for safety of CSA and UL	UL 508, CSA C22.2 No. 142
• for hazardous area of CSA and UL	UL 1604 and UL 2279-15 (Hazardous Location)
• for emitted interference	EN 61000-6-4:2001
• for interference immunity	EN 61000-6-2:2001
Verification of suitability	EN 61000-6-2:2001, EN 61000-6-4:2001
• CE mark	Yes
• C-Tick	Yes
• KC approval	No

Ordering data	Order No.	Accessories	Order No.
<p>CSM 377 Compact Switch Module</p> <p>Unmanaged switch for connecting a SIMATIC S7-300, ET200 M and up to three further nodes to Industrial Ethernet with 10/100 Mbit/s; 4 x RJ45 ports; external 24 V DC power supply, diagnostics on LEDs, S7-300 module including electronic manual on CD-ROM</p>	<p>6GK7 377-1AA00-0AA0</p>	<p>IE FC TP standard cable GP 2 x 2 (Type A)</p> <p>4-core, shielded TP installation cable for connection to IE FC outlet RJ45/ IE FC RJ45 plug; PROFINET-compliant; with UL approval; sold by the meter; max. quantity 1000 m, minimum order 20 m</p> <hr/> <p>IE FC RJ45 Plug 180 2 x 2</p> <p>RJ45 plug connector for Industrial Ethernet with a rugged metal housing and integrated insulation displacement contacts for connecting Industrial Ethernet FC installation cables; 180° cable outlet; for network components and CPs/CPUs with Industrial Ethernet interface</p> <ul style="list-style-type: none"> • 1 pack = 1 unit • 1 pack = 10 units • 1 pack = 50 units <hr/> <p>IE FC stripping tool</p> <p>Preadjusted stripping tool for fast stripping of the Industrial Ethernet FC cables</p>	<p>6XV1 840-2AH10</p> <hr/> <p>6GK1 901-1BB10-2AA0 6GK1 901-1BB10-2AB0 6GK1 901-1BB10-2AE0</p> <hr/> <p>6GK1 901-1GA00</p>

SIMATIC S7-300

Communication

TIM 3V-IE for WAN and Ethernet

Overview



- SINAUT communications module TIM for SIMATIC S7-300 for use in a wide area network (WAN)
- IP communication via secure VPN (virtual private network) using the Internet
- Wireless communication via GPRS router, GPRS modem, or radio devices
- Wired communication via Ethernet, DSL, dialup modems or dedicated line modem
- Complete migration of existing wireless, dedicated line and dial-up technology to IP-based network
- Message frame memory for complete recording of data
- Simple configuration and operation without specialist IT knowledge

5

Technical specifications

Order No.	6NH7 800-3BA00
Product-type designation	TIM 3V-IE
Transmission rate	
• for Industrial Ethernet	10 ... 100 Mbit/s
• in accordance with RS 232	50 ... 38 400 bit/s
Interfaces	
Number of interfaces according to Industrial Ethernet	1
Number of electrical connections	
• for external data transmission in accordance with RS 232	1
• for power supply	1
Design of electrical connection	
• the Industrial Ethernet Interface	
• at interface 1 for external data transmission	
• at interface 2 for external data transmission	-
• for power supply	
design of the removable storage C-PLUG	No
Supply voltage, current consumption, power loss	
Type of voltage of supply voltage	DC
Supply voltage	24 V
• minimum	20.4 V
• maximum	28.8 V
Consumed current	
• from backplane bus at 24 V for DC maximum	0.2 A
• from external supply voltage at 24 V at DC maximum	0.2 A
Resistive loss	5.8 W
Product expansion optional backup battery	No
Type of battery	-
Backup current	
• typical	-
• maximum	-

Order No.	6NH7 800-3BA00
Product-type designation	TIM 3V-IE
Permitted ambient conditions	
Ambient temperature	
• during operating	0 ... 60 °C
• during storage	-40 ... +70 °C
• during transport	-40 ... +70 °C
Relative humidity at 25 °C without condensation during operating maximum	95 %
Protection class IP	IP20
Design, dimensions and weight	
Module format	
Width	40 mm
Height	125 mm
Depth	120 mm
Net weight	0.25 kg
Product properties, functions, components general	
Number of modules note	Number of TIMs per S7-300: 1
Cable length	
• with RS232 interface maximum	6 m
• with RS485 interface maximum	-
Performance data	
<u>Performance data S7 communication</u>	
Number of possible connections for S7 communication	
• maximum	8
• with PG connections maximum	2
• with OP connections maximum	8
• note	-
Service	
• SINAUT ST7 through S7 communication	Yes
• PG-/OP-communication	Yes

Technical specifications (continued)

Order No.	6NH7 800-3BA00
Product-type designation	TIM 3V-IE
Performance data multi-protocol mode	
Number of active connections with multiprotocol mode	12
Performance data telecontrol	
Suitability for use	
• TIM node station	No
• TIM station	Yes
• TIM control center	No
• note	
Protocol will be supported TCP/IP	Yes
Protocol is supported DNP3	No
Protocol will be supported SINAUT ST1 protocol	Yes
Protocol will be supported SINAUT ST7 protocol	Yes
Product function data buffering if connection is aborted	Yes
• note	16,000 data messages
Storage capacity	
• of user memory of S7 CPU	
- for TD7onCPU mode data blocks on CPU required	20 Kibyte
- for TD7onTIM mode data blocks on TIM required	0 Kibyte
• note	TD7onCPU: at least 20 KB, actual requirement determined by data volume and functional scope TD7onTIM: 0 bytes in most favorable case
Product property retentive message frame memory	No
Transmission format	
• for SINAUT ST1 protocol with polling 11 bit	Yes
• for SINAUT ST1 protocol with spontaneous 10 bit or 11 bit	Yes
• for SINAUT ST7 protocol with multi-master polling 10 bit	Yes
• for SINAUT ST7 protocol with polling or spontaneous 10 bit or 11 bit	Yes
Operating mode for scanning of data transmission	
• with dedicated line/radio link	
- with SINAUT ST1 protocol	Polling, polling with time slot procedure
- with SINAUT ST7 protocol	Polling, polling with time slot procedure, multi-master polling with time slot procedure
• with dial-up network	
- with SINAUT ST1 protocol	spontaneous
- with SINAUT ST7 protocol	spontaneous
Hamming distance	
• for SINAUT ST1 protocol	4
• for SINAUT ST7 protocol	4

Order No.	6NH7 800-3BA00
Product-type designation	TIM 3V-IE
Product functions management, configuration	
Configuration software	
• required	STEP7 V5.5 or higher plus SINAUT ST7 Engineering Software
• for CPU configuring required SINAUT TD7 block library for CPU	Yes
• for PG configuring required SINAUT ST7 configuration software for PG	Yes
Storage location of TIM configuration data	On the TIM
Product functions security Virtual Private Network	
Suitability for installation Virtual Private Network	Yes
Product function	
• password protection for VPN	Yes
• MSC client via GPRS modem with MSC capability	Yes
Protocol is supported MSC protocol	No
Number of possible connections	
• as MSC client with VPN connection	1
• as MSC server with VPN connection	0
Protocol with Virtual Private Network MSC is supported	-
Key length for MSC with Virtual Private Network	128 bit
Type of authentication with Virtual Private Network PSK	Yes
Operating mode Virtual Private Network note	VPN operation as MSC client with MSC protocol and password protection only possible in conjunction with GPRS modem with MSC capability
Product functions Time	
Product component Hardware real-time clock	-
Product property battery-backed hardware real-time clock	-
Accuracy of hardware real-time clock per day maximum	-

SIMATIC S7-300

Communication

TIM 3V-IE for WAN and Ethernet

Ordering data

Order No.

TIM 3V-IE communications module

With an RS232 interface for SINAUT communication via a conventional WAN or an IP-based network (WAN or LAN)

6NH7 800-3BA00

SINAUT Engineering Software V5.3

On CD-ROM, comprising

- SINAUT Engineering Software V5.3 for the programming device
- SINAUT TD7 block library
- Electronic manual in German and English

6NH7 997-0CA53-0AA0

SINAUT Engineering Software V5.3 Upgrade from V5.0, 5.1 or 5.2

for adding functional expansions; the functional expansions are for transferring larger data quantities of 1 KB and SMS functionality in GPRS mode

6NH7 997-0CA53-0GA0

SINAUT ST7 Engineering Software V5.0 09/2009 (Upgrade)

for STEP 7 V5.4 SP4, for owners of older versions of SINAUT ST7 engineering software

6NH7 997-0CA50-0GA0

Order No.

Accessories

IE FC TP Standard Cable GP 2 x 2 (Type A)

4-core, shielded TP installation cable for connection to IE FC Outlet RJ45/IE FC RJ45 Plug; PROFINET-compatible; with UL approval; sold by the meter; max. length 1000 m, minimum order quantity 20 m

6XV1 840-2AH10

IE FC RJ45 Plug 180

RJ45 plug-in connector for Industrial Ethernet with a rugged metal housing and integrated insulation displacement contacts for connecting Industrial Ethernet FC installation cables; with 180° cable outlet; for network components and CPs/CPU with Industrial Ethernet interface

- 1 pack = 1 unit
- 1 pack = 10 units
- 1 pack = 50 units

6GK1 901-1BB10-2AA0
6GK1 901-1BB10-2AB0
6GK1 901-1BB10-2AE0

IE FC Stripping Tool

Preadjusted stripping tool for fast stripping of the Industrial Ethernet FC cables

6GK1 901-1GA00

Connecting cable

For connecting a TIM (RS232) with a SINAUT ST7 MD2, MD3 or MD4 (RS232) modem; cable length 1.5 m

6NH7 701-4AL

Connecting cable

For connecting a TIM (RS232) with the GSM modem MD720-3; also suitable for third-party modems or radio equipment with standard RS232 interface; cable length 2.5 m

6NH7 701-5AN

Connecting cable

with one end open for connecting a TIM (RS232) to a third-party modem or radio unit (RS232); cable length 2.5 m

6NH7 701-4BN

Connecting cable

For connecting two TIM modules via their RS232 interface without modems ("null modem"); cable length 6 m

6NH7 701-0AR

Overview



- SINAUT communications module TIM for SIMATIC S7-300 for use in wide area network (WAN) as station, node station, and control center
- IP communication via secure VPN (virtual private network) using the Internet
- Wireless communication via GPRS router, GPRS modem or radio devices
- Wired communication via Ethernet, DSL, dialup modems or dedicated line modem
- Complete migration of existing wireless, dedicated line and dial-up technology to IP-based network
- Message frame memory for complete recording of data and support of redundant communication paths
- Simple configuration and operation without specialist IT knowledge

5

Technical specifications

Order No.	6NH7 800-3CA00
Product-type designation	TIM 3V-IE Advanced
Transmission rate	
Transfer rate	
• for Industrial Ethernet	10 ... 100 Mbit/s
• in accordance with RS 232	50 ... 38 400 bit/s
Interfaces	
Number of interfaces according to Industrial Ethernet	1
Number of electrical connections	
• for external data transmission in accordance with RS 232	1
• for power supply	1
Design of electrical connection	
• the Industrial Ethernet Interface	
• at interface 1 for external data transmission	
• at interface 2 for external data transmission	-
• for power supply	
design of the removable storage C-PLUG	No
Supply voltage, current consumption, power loss	
Type of voltage of supply voltage	DC
Supply voltage	24 V
• minimum	20.4 V
• maximum	28.8 V
Consumed current	
• from backplane bus at 24 V for DC maximum	0.2 A
• from external supply voltage at 24 V at DC maximum	0.2 A
Resistive loss	5.8 W
Product expansion optional backup battery	No
Type of battery	-
Backup current	
• typical	-
• maximum	-

Order No.	6NH7 800-3CA00
Product-type designation	TIM 3V-IE Advanced
Permitted ambient conditions	
Ambient temperature	
• during operating	0 ... 60 °C
• during storage	-40 ... +70 °C
• during transport	-40 ... +70 °C
Relative humidity at 25 °C without condensation during operating maximum	95 %
Protection class IP	IP20
Design, dimensions and weight	
Module format	
Width	40 mm
Height	125 mm
Depth	120 mm
Net weight	0.25 kg
Product properties, functions, components general	
Number of modules note	Number of TIMs per S7-300: multiple, number depends on the connection resources of the S7-300 CPU
Cable length	
• with RS232 interface maximum	6 m
• with RS485 interface maximum	-
Performance data	
<u>Performance data S7 communication</u>	
Number of possible connections for S7 communication	
• maximum	24
• with PG connections maximum	4
• with OP connections maximum	20
• note	-
Service	
• SINAUT S7 through S7 communication	Yes
• PG-/OP-communication	Yes

SIMATIC S7-300

Communication

TIM 3V-IE Advanced

Technical specifications (continued)

Order No.	6NH7 800-3CA00
Product-type designation	TIM 3V-IE Advanced
Performance data <u>multi-protocol mode</u>	
Number of active connections with multiprotocol mode	24
Performance data <u>telecontrol</u>	
Suitability for use	
• TIM node station	Yes
• TIM station	Yes
• TIM control center	Yes
• note	
Protocol will be supported	
• TCP/IP	Yes
• DNP3	No
• SINAUT ST1 protocol	Yes
• SINAUT ST7 protocol	Yes
Product function data buffering if connection is aborted	
• note	32,000 data messages
Storage capacity	
• of user memory of S7 CPU	
- for TD7onCPU mode data blocks on CPU required	20 Kibyte
- for TD7onTIM mode data blocks on TIM required	0 Kibyte
• note	TD7onCPU: at least 20 KB, actual requirement determined by data volume and functional scope TD7onTIM: 0 bytes in most favorable case
Product property retentive message frame memory	
	No
Transmission format	
• for SINAUT ST1 protocol with polling 11 bit	Yes
• for SINAUT ST1 protocol with spontaneous 10 bit or 11 bit	Yes
• for SINAUT ST7 protocol with multi-master polling 10 bit	Yes
• for SINAUT ST7 protocol with polling or spontaneous 10 bit or 11 bit	Yes
Operating mode for scanning of data transmission	
• with dedicated line/radio link	
- with SINAUT ST1 protocol	Polling, polling with time slot procedure
- with SINAUT ST7 protocol	Polling, polling with time slot procedure, multi-master polling with time slot procedure
• with dial-up network	
- with SINAUT ST1 protocol	spontaneous
- with SINAUT ST7 protocol	spontaneous
Hamming distance	
• for SINAUT ST1 protocol	4
• for SINAUT ST7 protocol	4

Order No.	6NH7 800-3CA00
Product-type designation	TIM 3V-IE Advanced
Product functions management, configuration	
Configuration software	
• required	STEP7 V5.5 or higher plus SINAUT ST7 Engineering Software Yes
• for CPU configuring required SINAUT TD7 block library for CPU	Yes
• for PG configuring required SINAUT ST7 configuration software for PG	
Storage location of TIM configuration data	On the TIM
Product functions security Virtual Private Network	
Suitability for installation Virtual Private Network	Yes
Product function	
• password protection for VPN	Yes
• MSC client via GPRS modem with MSC capability	Yes
Protocol is supported MSC protocol	Yes
Number of possible connections	
• as MSC client with VPN connection	1
• as MSC server with VPN connection	0
Protocol with Virtual Private Network MSC is supported	TCP/IP
Key length for MSC with Virtual Private Network	128 bit
Type of authentication with Virtual Private Network PSK	Yes
Operating mode Virtual Private Network note	-
Product functions Time	
Product component Hardware real-time clock	-
Product property battery-backed hardware real-time clock	-
Accuracy of hardware real-time clock per day maximum	-

Ordering data	Order No.	Order No.
TIM 3V-IE Advanced communications module With an RS232 interface and an RJ45 interface for SINAUT communication via a conventional WAN and an IP-based network (WAN or LAN)	6NH7 800-3CA00	
SINAUT Engineering Software V5.3 On CD-ROM, comprising <ul style="list-style-type: none"> • SINAUT Engineering Software V5.3 for the programming device • SINAUT TD7 block library • Electronic manual in German and English 	6NH7 997-0CA53-0AA0	
SINAUT Engineering Software V5.3 Upgrade from V5.0, 5.1 or 5.2 for adding functional expansions; the functional expansions are for transferring larger data quantities of 1 KB and SMS functionality in GPRS mode	6NH7 997-0CA53-0GA0	
SINAUT ST7 Engineering Software V5.0 Edition 09/2009 (Upgrade) for STEP 7 V5.4 SP4, for owners of older versions of SINAUT ST7 engineering software	6NH7 997-0CA50-0GA0	
		Accessories IE FC TP Standard Cable GP 2 x 2 (Type A) 4-core, shielded TP installation cable for connection to IE FC Outlet RJ45/IE FC RJ45 Plug; PROFINET-compatible; with UL approval; sold by the meter; max. length 1000 m, minimum order quantity 20 m
		IE FC RJ45 Plug 180 RJ45 plug-in connector for Industrial Ethernet with a rugged metal housing and integrated insulation displacement contacts for connecting Industrial Ethernet FC installation cables; with 180° cable outlet; for network components and CPs/CPUs with Industrial Ethernet interface <ul style="list-style-type: none"> • 1 pack = 1 unit • 1 pack = 10 units • 1 pack = 50 units
		IE FC Stripping Tool Preadjusted stripping tool for fast stripping of the Industrial Ethernet FC cables
		Connecting cable For connecting a TIM (RS232) with a SINAUT ST7 MD2, MD3 or MD4 (RS232) modem; cable length 1.5 m
		Connecting cable For connecting a TIM (RS232) with the GSM modem MD720-3; also suitable for third-party modems or radio equipment with standard RS232 interface; cable length 2.5 m
		Connecting cable with one end open for connecting a TIM (RS232) to a third-party modem or radio unit (RS232); cable length 2.5 m
		Connecting cable For connecting two TIM modules via their RS232 interface without modems ("null modem"); cable length 6 m
		6XV1 840-2AH10 6GK1 901-1BB10-2AA0 6GK1 901-1BB10-2AB0 6GK1 901-1BB10-2AE0 6GK1 901-1GA00

SIMATIC S7-300

Communication

TIM 4R-IE for WAN and Ethernet

Overview



- SINAUT communications module TIM with four interfaces for SIMATIC S7-300 or as self-contained unit for the S7-400 for use in the wide area network (WAN)
- For universal use in a SINAUT station, node station and control center
- Internet communication via integrated MSC-VPN tunnel with direct connection to DSL router or operation via IPsec VPN with additional SIMATIC NET components
- Wireless communication via GPRS router, GPRS modem, or radio devices
- Wired communication via Ethernet, DSL, dialup modems or dedicated line modem
- Complete migration of existing wireless, dedicated line and dial-up technology to IP-based network
- Message frame memory for complete recording of data and support of redundant communication paths
- Simple configuration and operation without specialist IT knowledge

Technical specifications

Order No.	6NH7 800-4BA00
Product-type designation	TIM 4R-IE
Transmission rate	
Transfer rate	
• for Industrial Ethernet	10 ... 100 Mbit/s
• in accordance with RS 232	50 ... 38 400 bit/s
Interfaces	
Number of interfaces according to Industrial Ethernet	2
Number of electrical connections	
• for external data transmission in accordance with RS 232	2
• for power supply	1
Design of electrical connection	
• the Industrial Ethernet Interface	
• at interface 1 for external data transmission	
• at interface 2 for external data transmission	
• for power supply	
design of the removable storage C-PLUG	Yes
Supply voltage, current consumption, power loss	
Type of voltage of supply voltage	DC
Supply voltage	24 V
• minimum	20.4 V
• maximum	28.8 V
Consumed current	
• from backplane bus at 24 V for DC maximum	0.2 A
• from external supply voltage at 24 V at DC maximum	0.17 A
Resistive loss	4.6 W
Product expansion optional backup battery	Yes
Type of battery	Lithium AA / 3.6 V / 2.3 Ah
Backup current	
• typical	100 µA
• maximum	160 µA

Order No.	6NH7 800-4BA00
Product-type designation	TIM 4R-IE
Permitted ambient conditions	
Ambient temperature	
• during operating	0 ... 60 °C
• during storage	-40 ... +70 °C
• during transport	-40 ... +70 °C
Relative humidity at 25 °C without condensation during operating maximum	95 %
Protection class IP	IP20
Design, dimensions and weight	
Module format	
Width	80 mm
Height	125 mm
Depth	120 mm
Net weight	0.4 kg
Product properties, functions, components general	
Number of modules note	Number of TIM 4R-IE per S7-300/S7-400: multiple, number depends on the connection resources of the CPU
Cable length	
• with RS232 interface maximum	6 m
• with RS485 interface maximum	30 m
Performance data	
<u>Performance data S7 communication</u>	
Number of possible connections for S7 communication	
• maximum	64
• with PG connections maximum	2
• with OP connections maximum	62
• note	-
Service	
• SINAUT ST7 through S7 communication	Yes
• PG-/OP-communication	Yes

Technical specifications (continued)

Order No.	6NH7 800-4BA00
Product-type designation	TIM 4R-IE
Performance data multi-protocol mode	
Number of active connections with multiprotocol mode	128
Performance data telecontrol	
Suitability for use	
• TIM node station	Yes
• TIM station	Yes
• TIM control center	Yes
• note	-
Protocol will be supported	
• TCP/IP	Yes
• DNP3	No
• SINAUT ST1 protocol	Yes
• SINAUT ST7 protocol	Yes
Product function data buffering if connection is aborted	
• note	56,000 data messages
Storage capacity	
• of user memory of S7 CPU	
- for TD7onCPU mode data blocks on CPU required	20 Kibyte
- for TD7onTIM mode data blocks on TIM required	0 Kibyte
• note	TD7onCPU: at least 20 KB, actual requirement determined by data volume and functional scope TD7onTIM: 0 bytes in most favorable case
Product property retentive message frame memory	
	Yes
Transmission format	
• for SINAUT ST1 protocol with polling 11 bit	
	Yes
• for SINAUT ST1 protocol with spontaneous 10 bit or 11 bit	
	Yes
• for SINAUT ST7 protocol with multi-master polling 10 bit	
	Yes
• for SINAUT ST7 protocol with polling or spontaneous 10 bit or 11 bit	
	Yes
Operating mode for scanning of data transmission	
• with dedicated line/radio link	
- with SINAUT ST1 protocol	Polling, polling with time slot procedure
- with SINAUT ST7 protocol	Polling, polling with time slot procedure, multi-master polling with time slot procedure
• with dial-up network	
- with SINAUT ST1 protocol	spontaneous
- with SINAUT ST7 protocol	spontaneous
Hamming distance	
• for SINAUT ST1 protocol	4
• for SINAUT ST7 protocol	4

Order No.	6NH7 800-4BA00
Product-type designation	TIM 4R-IE
Product functions management, configuration	
Configuration software	
• required	STEP7 V5.5 or higher plus SINAUT ST7 Engineering Software
• for CPU configuring required SINAUT TD7 block library for CPU	Yes
• for PG configuring required SINAUT ST7 configuration software for PG	Yes
Storage location of TIM configuration data	
	On internal TIM flash memory, or on TIM in optional C-PLUG, or on MMC of the S7-300 CPU if TIM installed in S7-300 controller
Product functions security Virtual Private Network	
Suitability for installation Virtual Private Network	
	Yes
Product function	
• password protection for VPN	Yes
• MSC client via GPRS modem with MSC capability	Yes
Protocol is supported MSC protocol	
	Yes
Number of possible connections	
• as MSC client with VPN connection	1
• as MSC server with VPN connection	128
Protocol with Virtual Private Network MSC is supported	
	TCP/IP
Key length for MSC with Virtual Private Network	
	128 bit
Type of authentication with Virtual Private Network PSK	
	Yes
Operating mode Virtual Private Network note	
	-
Product functions Time	
Product component Hardware real-time clock	
	Yes
Product property battery-backed hardware real-time clock	
	Yes
Accuracy of hardware real-time clock per day maximum	
	4 s

SIMATIC S7-300

Communication

TIM 4R-IE for WAN and Ethernet

Ordering data

Order No.

TIM 4R-IE communications module

With two combined RS232/RS485 interfaces for SINAUT communication via conventional WANs and two RJ45 interfaces for SINAUT communication via IP-based networks (WAN or LAN)

6NH7 800-4BA00

SINAUT Engineering Software V5.3

On CD-ROM, comprising

- SINAUT Engineering Software V5.3 for the programming device
- SINAUT TD7 block library
- Electronic manual in German and English

6NH7 997-0CA53-0AA0

SINAUT Engineering Software V5.3 Upgrade from V5.0, 5.1 or 5.2

for adding functional expansions; the functional expansions are for transferring larger data quantities of 1 KB and SMS functionality in GPRS mode

6NH7 997-0CA53-0GA0

SINAUT ST7 Engineering Software V5.0 Edition 09/2009 (Upgrade)

for STEP 7 V5.4 SP4, for owners of older versions of SINAUT ST7 engineering software

6NH7 997-0CA50-0GA0

Order No.

Accessories

Backup battery

3.6 V/2.3 Ah for TIM 4R-IE

6ES7 971-0BA00

IE FC TP Standard Cable GP 2 x 2 (Type A)

4-core, shielded TP installation cable for connection to IE FC Outlet RJ45/IE FC RJ45 Plug; PROFINET-compatible; with UL approval; sold by the meter; max. length 1000 m, minimum order quantity 20 m

6XV1 840-2AH10

IE FC RJ45 Plug 180

RJ45 plug-in connector for Industrial Ethernet with a rugged metal housing and integrated insulation displacement contacts for connecting Industrial Ethernet FC installation cables; with 180° cable outlet; for network components and CPs/CPUs with Industrial Ethernet interface

- 1 pack = 1 unit
- 1 pack = 10 units
- 1 pack = 50 units

6GK1 901-1BB10-2AA0
6GK1 901-1BB10-2AB0
6GK1 901-1BB10-2AE0

IE FC Stripping Tool

Preadjusted stripping tool for fast stripping of the Industrial Ethernet FC cables

6GK1 901-1GA00

Connecting cable

For connecting a TIM (RS232) with a SINAUT ST7 MD2, MD3 or MD4 (RS232) modem; cable length 1.5 m

6NH7 701-4AL

Connecting cable

For connecting a TIM (RS485) with a SINAUT ST7 MD2, MD3 or MD4 (RS485) modem; cable length 1.5 m

6NH7 701-4DL

Connecting cable

For connecting a TIM (RS232) with the GSM modem MD720-3; also suitable for third-party modems or radio equipment with standard RS232 interface; cable length 2.5 m

6NH7 701-5AN

Connecting cable

with one end open for connecting a TIM (RS232) to a third-party modem or radio unit (RS232); cable length 2.5 m

6NH7 701-4BN

Connecting cable

For connecting two TIM modules via their RS232 interface without modems ("null modem"); cable length 6 m

6NH7 701-0AR

SITOP compact 24 V/ 0.6 A

1-phase power supply with wide-range input 85 ... 264 V AC/110 ... 300 V DC, stabilized output voltage 24 V, rated output current value 0.6 A, slim design

6EP1 331-5BA00

Overview



In an S7 station, the communications module TIM 3V-IE DNP3 (Telecontrol Interface Module) processes the data traffic for the S7-CPU to the assigned master system SIMATIC PCS7 TeleControl V7.1 SP2 using the open protocol DNP3 (Distributed Network Protocol).

- with the S7-300 housing, can be fully integrated into the S7-300 system
- RS232 interface for the connection of an external modem for data transmission via a conventional WAN or the connection of a Modbus RTU slave to an S7-300 system
- RJ45 port for data transmission via IP-based networks

Technical specifications

Order No.	6NH7 803-3BA00-0AA0
Product-type designation	TIM 3V-IE DNP3
Transmission rate	
Transfer rate	
• for Industrial Ethernet	10 ... 100 Mbit/s
• in accordance with RS 232	300 ... 38 400 bit/s
Interfaces	
Number of interfaces according to Industrial Ethernet	1
Number of electrical connections	
• for external data transmission in accordance with RS 232	1
• for power supply	1
Design of electrical connection	
• the Industrial Ethernet Interface	
• at interface 1 for external data transmission	
• at interface 2 for external data transmission	-
• for power supply	
design of the removable storage C-PLUG	No
Supply voltage, current consumption, power loss	
Type of voltage of supply voltage	DC
Supply voltage	24 V
• minimum	20.4 V
• maximum	28.8 V
Consumed current	
• from backplane bus at 24 V for DC maximum	0.2 A
• from external supply voltage at 24 V at DC maximum	0.2 A
Resistive loss	5.8 W
Product expansion optional backup battery	No
Type of battery	-
Backup current	
• typical	-
• maximum	-

Order No.	6NH7 803-3BA00-0AA0
Product-type designation	TIM 3V-IE DNP3
Permitted ambient conditions	
Ambient temperature	
• during operating	0 ... 60 °C
• during storage	-40 ... +70 °C
• during transport	-40 ... +70 °C
Relative humidity at 25 °C without condensation during operating maximum	95 %
Protection class IP	IP20
Design, dimensions and weight	
Module format	
Width	40 mm
Height	125 mm
Depth	120 mm
Net weight	0.25 kg
Product properties, functions, components general	
Number of modules note	Number of TIMs per S7-300: 1
Cable length	
• with RS232 interface maximum	6 m
• with RS485 interface maximum	-
Performance data	
<u>Performance data S7 communication</u>	
Number of possible connections for S7 communication	
• maximum	3
• with PG connections maximum	2
• with OP connections maximum	1
• note	only via LAN
Service	
• SINAUT ST7 through S7 communication	-
• PG-/OP-communication	Yes
<u>Performance data multi-protocol mode</u>	
Number of active connections with multiprotocol mode	-

SIMATIC S7-300

Communication

TIM 3V-IE DNP3

Technical specifications (continued)

Order No.	6NH7 803-3BA00-0AA0	Order No.	6NH7 803-3BA00-0AA0
Product-type designation	TIM 3V-IE DNP3	Product-type designation	TIM 3V-IE DNP3
Performance data <u>telecontrol</u>		Product functions management, configuration	
Suitability for use		Configuration software required	STEP7 V5.5 or higher plus SINAUT ST7 Engineering Software
• TIM node station	No	Storage location of TIM configuration data	On the CPU or TIM
• TIM station	Yes		
• TIM control center	No		
• note	-	Product functions Time	
Protocol will be supported TCP/IP	Yes	Product component Hardware real-time clock	-
Protocol is supported DNP3	Yes	Product property battery-backed hardware real-time clock	-
Protocol will be supported SINAUT ST1 protocol	No	Accuracy of hardware real-time clock per day maximum	-
Protocol will be supported SINAUT ST7 protocol	No		
Number of DNP3 masters Number of DNP3 masters			
• with Ethernet maximum	8		
• with RS 232 interface maximum	1		
Product function data buffering if connection is aborted	Yes		
• note			

Ordering data

Ordering data	Order No.	Ordering data	Order No.
TIM 3V-IE DNP3 communications module	6NH7 803-3BA00-0AA0	IE FC RJ45 Plug 180	
With an RS232 interface for SINAUT communication via a conventional WAN and an IP-based network (WAN or LAN)		RJ45 plug-in connector for Industrial Ethernet with a rugged metal housing and integrated insulation displacement contacts for connecting Industrial Ethernet FC installation cables; with 180° cable outlet; for network components and CPs/CPUs with Industrial Ethernet interface	
SINAUT Engineering Software V5.3	6NH7 997-0CA53-0AA0	• 1 pack = 1 unit • 1 pack = 10 units • 1 pack = 50 units	6GK1 901-1BB10-2AA0 6GK1 901-1BB10-2AB0 6GK1 901-1BB10-2AE0
On CD-ROM, comprising		IE FC stripping tool	6GK1 901-1GA00
• SINAUT ST7 Engineering Software V5.3 for the PG		Preadjusted stripping tool for fast stripping of the Industrial Ethernet FC cables	
• SINAUT TD7 block library		Connecting cable	6NH7 701-4AL
• Electronic manual in German and English		For connecting a TIM (RS232) with a SINAUT ST7 MD2, MD3 or MD4 (RS232) modem; cable length 1.5 m	
SINAUT Engineering Software V5.3	6NH7 997-0CA53-0GA0	Connecting cable	6NH7 701-5AN
Upgrade from V5.0, 5.1, or V5.2		For connecting a TIM (RS232) with the GSM modem MD720-3; also suitable for third-party modems or wireless equipment with standard RS232 interface; cable length 2.5 m	
For adding functional expansions; the functional expansions are for transferring larger data quantities of 1 KB and SMS functionality in GPRS mode		Connecting cable	6NH7 701-4BN
SINAUT ST7 Engineering Software V5.0 Edition 09/2009 (Upgrade)	6NH7 997-0CA50-0GA0	with one end open for connecting a TIM (RS232) to a third-party modem or wireless device (RS232); cable length 2.5 m	
for STEP 7 V5.4 SP4, for owners of older versions of SINAUT ST7 engineering software		Connecting cable	6NH7 701-0AR
Accessories		For connecting two TIM modules via their RS232 interface without modems ('Null modem'). Cable length 6 m	
IE FC TP Standard Cable GP 2 x 2 (Type A)	6XV1 840-2AH10		
4-core, shielded TP installation cable for connection to IE FC RJ45 outlet / IE FC RJ45 plug; PROFINET-compliant; with UL approval; sold by the meter; max. length 1000 m, minimum order 20 m			

Overview



In an S7 station, the communications module TIM 4R-IE DNP3 (Telecontrol Interface Module) processes the data traffic for the S7-CPU to the assigned master system SIMATIC PCS7 TeleControl V7.1 SP2 using the open protocol DNP3 (Distributed Network Protocol).

- with the double-width S7-300 housing, can be fully integrated into the S7-300 system
- Can be connected as a stand-alone to a SIMATIC S7-400 and SIMATIC S7-400 H System
- Two RS232/RS485 interfaces for the connection of an external modem for data transmission via a conventional WAN or of a Modbus RTU slave to an S7-300 system
- Two RJ45 interfaces for data transmission via IP-based networks
- By the use of physically separate connection paths, the module permits media redundancy without loss of data during the switchover

Technical specifications

Order No.	6NH7 803-4BA00-0AA0
Product-type designation	TIM 4R-IE DNP3
Transmission rate	
Transfer rate	
• for Industrial Ethernet	10 ... 100 Mbit/s
• in accordance with RS 232	300 ... 115 200 bit/s
Interfaces	
Number of interfaces according to Industrial Ethernet	2
Number of electrical connections	
• for external data transmission in accordance with RS 232	2
• for power supply	1
Design of electrical connection	
• the Industrial Ethernet Interface	
• at interface 1 for external data transmission	
• at interface 2 for external data transmission	
• for power supply	
design of the removable storage C-PLUG	Yes
Supply voltage, current consumption, power loss	
Type of voltage of supply voltage	DC
Supply voltage	24 V
• minimum	20.4 V
• maximum	28.8 V
Consumed current	
• from backplane bus at 24 V for DC maximum	0.2 A
• from external supply voltage at 24 V at DC maximum	0.17 A
Resistive loss	4.6 W
Product expansion optional backup battery	Yes
Type of battery	Lithium AA / 3.6 V / 2.3 Ah
Backup current	
• typical	100 µA
• maximum	160 µA

Order No.	6NH7 803-4BA00-0AA0
Product-type designation	TIM 4R-IE DNP3
Permitted ambient conditions	
Ambient temperature	
• during operating	0 ... 60 °C
• during storage	-40 ... +70 °C
• during transport	-40 ... +70 °C
Relative humidity at 25 °C without condensation during operating maximum	95 %
Protection class IP	IP20
Design, dimensions and weight	
Module format	
Width	80 mm
Height	125 mm
Depth	120 mm
Net weight	0.4 kg
Product properties, functions, components general	
Number of modules note	Number of TIMs per S7-300 / S7-400: 1
Cable length	
• with RS232 interface maximum	6 m
• with RS485 interface maximum	30 m
Performance data	
<u>Performance data</u> <u>S7 communication</u>	
Number of possible connections for S7 communication	
• maximum	5
• with PG connections maximum	2
• with OP connections maximum	1
Number of possible connections for S7 communication note	only via LAN
Service	
• SINAUT ST7 through S7 communication	-
• PG-/OP-communication	Yes

SIMATIC S7-300

Communication

TIM 4R-IE DNP3

Technical specifications (continued)

Order No.	6NH7 803-4BA00-0AA0
Product-type designation	TIM 4R-IE DNP3
<u>Performance data</u> multi-protocol mode	
Number of active connections with multiprotocol mode	-
<u>Performance data</u> telecontrol	
Acceptability for application	
• TIM node station	No
• TIM station	Yes
• TIM control center	No
Suitability for use note	-
Protocol will be supported	
• TCP/IP	Yes
• DNP3	Yes
• SINAUT ST1 protocol	No
• SINAUT ST7 protocol	No
Number of DNP3 masters	
• with Ethernet maximum	8
• with RS 232 interface maximum	1
Product function data buffering if connection is aborted	Yes
• note	200 000 data points with one master

Order No.	6NH7 803-4BA00-0AA0
Product-type designation	TIM 4R-IE DNP3
Product functions management, configuration	
Configuration software required	STEP7 V5.5 or higher plus SINAUT ST7 Engineering Software
Storage location of TIM configuration data	On the CPU or TIM
Product functions Time	
Product component Hardware real-time clock	Yes
Product property battery-backed hardware real-time clock	Yes
Accuracy of hardware real-time clock per day maximum	4 s

Ordering data	Order No.	Order No.	
TIM 4R-IE DNP3 communications module With two combined RS232/RS485 interfaces for SINAUT communication via conventional WANs and two RJ45 interfaces for SINAUT communication via IP-based networks (WAN or LAN)	6NH7 803-4BA00-0AA0	IE FC stripping tool Preadjusted stripping tool for fast stripping of the Industrial Ethernet FC cables	6GK1 901-1GA00
SINAUT Engineering Software V5.3 On CD-ROM, comprising <ul style="list-style-type: none"> • SINAUT ST7 Engineering Software V5.3 for the PG • SINAUT TD7 block library • Electronic manual in German and English 	6NH7 997-0CA53-0AA0	Connecting cable For connecting a TIM (RS232) with a SINAUT ST7 MD2, MD3 or MD4 (RS232) modem; cable length 1.5 m	6NH7 701-4AL
SINAUT Engineering Software V5.3 Upgrade from V5.0, 5.1, or V5.2 For adding functional expansions; the functional expansions are for transferring larger data quantities of 1 KB and SMS functionality in GPRS mode	6NH7 997-0CA53-0GA0	Connecting cable For connecting a TIM (RS485) with a SINAUT ST7 MD2, MD3 or MD4 (RS485) modem; cable length 1.5 m	6NH7 701-4DL
SINAUT ST7 Engineering Software V5.0 Edition 09/2009 (Upgrade) for STEP 7 V5.4 SP4, for owners of older versions of SINAUT ST7 engineering software	6NH7 997-0CA50-0GA0	Connecting cable For connecting a TIM (RS232) with the GSM modem MD720-3; also suitable for third-party modems or wireless equipment with standard RS232 interface; cable length 2.5 m	6NH7 701-5AN
Accessories Backup battery 3.6 V/2.3 Ah for TIM 4R-IE DNP3	6ES7 971-0BA00	Connecting cable with one end open for connecting a TIM (RS232) to a third-party modem or wireless device (RS232); cable length 2.5 m	6NH7 701-4BN
IE FC TP Standard Cable GP 2 x 2 (Type A) 4-core, shielded TP installation cable for connection to IE FC RJ45 outlet / IE FC RJ45 plug; PROFINET-compliant; with UL approval; sold by the meter; max. quantity 1000 m, minimum order quantity 20 m	6XV1 840-2AH10	Connecting cable For connecting two TIM modules via their RS232 interface without modems ('Null modem'). Cable length 6 m	6NH7 701-0AR
IE FC RJ45 Plug 180 RJ45 plug-in connector for Industrial Ethernet with a rugged metal housing and integrated insulation displacement contacts for connecting Industrial Ethernet FC installation cables; with 180° cable outlet; for network components and CPs/CPU's with Industrial Ethernet interface <ul style="list-style-type: none"> • 1 pack = 1 unit • 1 pack = 10 units • 1 pack = 50 units 	6GK1 901-1BB10-2AA0 6GK1 901-1BB10-2AB0 6GK1 901-1BB10-2AE0	SITOP compact 24 V/ 0.6 A 1-phase power supply with wide-range input 85 to 264 V AC/ 110 to 300 V DC, stabilized output voltage 24 V, rated output current value 0.6 A, slim design	6EP1 331-5BA00
		SITOP compact 24 V/ 0.6 A 1-phase power supply with wide-range input 85 to 264 V AC/ 110 to 300 V DC, stabilized output voltage 24 V, rated output current value 0.6 A, slim design	6EP1 331-5BA00

SIMATIC S7-300

Communication

MD741-1 EGPRS router

Overview



- EGPRS (GPRS with Edge) and GPRS router for wireless IP communication from Ethernet-based automation devices over GSM mobile radio networks
- Four times the transmission speed by means of EGPRS
- Integrated security functions with firewall and VPN (IPsec)

5

Technical specifications

Order No.	6NH9 741-1AA00
Product-type designation	SINAUT MD 741-1 EGPRS router
Transmission rate	-
Transfer rate	
• 1 for Industrial Ethernet	10 Mbit/s
• 2 for Industrial Ethernet	100 Mbit/s
• for GSM transmission	9 600 bit/s
• with GPRS transmission	
- with downlink maximum	85.6 kbit/s
- with uplink maximum	85.6 kbit/s
• with eGPRS transmission	
- with downlink maximum	236.8 kbit/s
- with uplink maximum	236.8 kbit/s
Interfaces	-
Number of electrical connections	
• for network components and terminal equipment	1
• for external antenna(s)	1
• for power supply	1
Design of electrical connection	
• for network components and terminal equipment	-
• for external antenna(s)	SMA antenna socket (50 ohms)
Inputs/outputs	-
Number of electrical connections	
• for digital input signals	-
• for digital output signals	-
Design of electrical connection	
• for digital input signals	-
• for digital output signals	-

Order No.	6NH9 741-1AA00
Product-type designation	SINAUT MD 741-1 EGPRS router
WAN connection	-
Type of mobile wireless network is supported	
• GSM	Yes
Type of mobile wireless service is supported	
• GPRS	Yes
• eGPRS	Yes
Operating frequency for GSM transmission	
• 850 MHz	Yes
• 900 MHz	Yes
• 1800 MHz	Yes
• 1900 MHz	Yes
Type of GPRS time slot method	
Multislot Class 10	-
Supply voltage, current consumption, power loss	-
Type of voltage of supply voltage	DC
Supply voltage	24 V
• minimum	12 V
• maximum	30 V
Consumed current maximum	600 mA
Active power loss typical	4 W

Technical specifications (continued)

Order No.	6NH9 741-1AA00
Product-type designation	SINAUT MD 741-1 EGPRS router
Permitted ambient conditions	-
Ambient temperature	
• during operating	-20 ... +60 °C
• during storage	-40 ... +70 °C
Relative humidity at 25 °C during operating maximum	95 %
Protection class IP	IP20
Design, dimensions and weight	-
Design	compact
Depth	114 mm
Height	99 mm
Width	45 mm
Net weight	280 g
Type of mounting 35 mm DIN rail mounting	-
Type of mounting	-
Product properties, functions, components general	-
Product function DynDNS client	Yes
Product functions management, configuration	-
Product function	
• CLI	No
• web-based management	Yes
Protocol is supported	
• Telnet	No
• HTTP	No
• HTTPS	Yes
Type of configuration	Web interface
Product functions Diagnosis	-
Product function	
• Statistics Packet Size	No
• Statistics packet type	No
• Error statistics	No
• SysLog	Yes
• Packet Filter Log	Yes
Product functions DHCP	-
Product function	
• DHCP client	Yes
• DHCP server - internal network	Yes
Product functions Routing	-
Router function	
• NAT (IP masquerading)	Yes
• Port Forwarding	Yes
• NAT traversal	Yes
• 1:1 NAT	Yes
• DNS cache	Yes

Order No.	6NH9 741-1AA00
Product-type designation	SINAUT MD 741-1 EGPRS router
Product functions Security	-
Design of the firewall	-
Product function	
• Password protection	Yes
• Broadcast/Multicast/Unicast Limiter	-
• broadcast blocking	-
Suitability for installation Virtual Private Network	Yes
Product function with VPN connection	T
Number of possible connections for VPN connection	10
Number of network stations for internal network with VPN connection maximum	-
Type of authentication with Virtual Private Network PSK	Yes
Protocol will be supported IPsec tunnel and transport mode	Yes
Key length	
• with IPsec DES with Virtual Private Network	56 bit
• 1 with IPsec AES with Virtual Private Network	128 bit
• 2 with IPsec AES with Virtual Private Network	192 bit
• 3 with IPsec AES with Virtual Private Network	256 bit
Type of Internet key exchange with Virtual Private Network main mode	Yes
Key length with IPsec 3DES with Virtual Private Network	168 bit
Type of Internet key exchange with Virtual Private Network quick mode	Yes
Type of packet authentication with Virtual Private Network	-
IETF profile with Virtual Private Network X.509v3 certificate	Yes
Product functions Time	-
Router function NTP	Yes
Standards, specifications, approvals	-
Standard	
• for EMC	-
• for EMC from FM	-
• for hazardous zone	EN60079-15: II 3 G Ex nA IIC T4 Ta= -20°C to 60°C
• for safety of CSA and UL	UL 60950-1, CSA C22.2 Nr. 60950-1
• for hazardous area of CSA and UL	-
• for emitted interference	-
• for interference immunity	EN 61000-6-2
Verification of suitability	EN 61000-6-2
• CE mark	Yes
• C-Tick	-
• E1 approval	Yes
• e1 approval	Yes
• Railway application in accordance with EN 50155	No

SIMATIC S7-300

Communication

MD741-1 EGPRS router

Ordering data

MD741-1 EGPRS router¹⁾

For wireless IP communication by industrial Ethernet-based programmable controllers via GSM mobile radio networks; integrated firewall and VPN router (IPsec); quad band GSM; EGPRS Multislot Class 12

Accessories

IE FC RJ45 Plug 180

RJ45 plug-in connector for Industrial Ethernet with a rugged metal housing and integrated insulation displacement contacts for connecting Industrial Ethernet FC installation cables; with 180° cable outlet; for network components and CPs/CPU with Industrial Ethernet interface

- 1 pack = 1 unit
- 1 pack = 10 units
- 1 pack = 50 units

ANT794-3M GSM/GPRS antenna

Flat panel antenna for GSM (2G) networks, for triband with 900/1800/1900 MHz; weather-resistant for indoor/outdoor use, 1.2 m cable with fixed connection to antenna; SMA connector, Incl. assembly adhesive tape

ANT794-4MR GSM/GPRS antenna

Omnidirectional antenna for GSM (2G) and UMTS (3G) networks; weather-resistant for indoor and outdoor use; 5 m cable with fixed connection to antenna; SMA connector; including mounting bracket, screws, wall plugs

Order No.

6NH9 741-1AA00

6GK1 901-1BB10-2AA0
6GK1 901-1BB10-2AB0
6GK1 901-1BB10-2AE0

6NH9 870-1AA00

6NH9 860-1AA00

Order No.

SCALANCE S Industrial Security Modules

For protection of programmable controllers and automation networks, and for safeguarding of industrial communication; configuring tool and electronic manual on CD-ROM; German, English, French, Italian, Spanish

• SCALANCE S612

uses the stateful inspection firewall to protect network segments against unauthorized access; protects up to 32 devices up to 64 VPN tunnels simultaneously

• SCALANCE S623²⁾

uses the stateful inspection firewall to protect network segments against unauthorized access; protects up to 64 devices and up to 128 VPN tunnels simultaneously; enhanced temperature range (-20 to +70 °C)

6GK5 612-0BA00-2AA3

6GK5 623-0BA10-2AA3

IE TP Cord RJ45/RJ45

TP cable 4 x 2 with 2 RJ45 connectors

- 0.5 m
- 1 m
- 2 m
- 6 m
- 10 m

6XV1 870-3QE50
6XV1 870-3QH10
6XV1 870-3QH20
6XV1 870-3QH60
6XV1 870-3QN10

¹⁾ Please note national approvals under www.siemens.com/wireless-approvals

²⁾ Available soon

Overview



- UMTS, EGPRS (Edge GPRS) and GPRS router for wireless IP communication of Industrial Ethernet-based PLCs over UMTS/ GSM mobile wireless networks
- High data transfer rate thanks to UMTS
- Integrated security functions with firewall
- *SCALANCE M875*:
Use both as VPN server and as client (IPsec)

5

Technical specifications

Order No.	6GK5 873-0AA10-1AA2	6GK5 875-0AA10-1AA2
Product-type designation	SCALANCE M873	SCALANCE M875
Transmission rate		
Transfer rate		
• 1 for Industrial Ethernet	10 Mbit/s	10 Mbit/s
• 2 for Industrial Ethernet	100 Mbit/s	100 Mbit/s
• for GSM transmission	9 600 bit/s	9 600 bit/s
• with GPRS transmission		
- with downlink maximum	85.6 kbit/s	85.6 kbit/s
- with uplink maximum	85.6 kbit/s	42.8 kbit/s
• with eGPRS transmission		
- with downlink maximum	236.8 kbit/s	236.8 kbit/s
- with uplink maximum	236.8 kbit/s	118 kbit/s
• with UMTS transmission		
- with downlink maximum	3.6 Mbit/s	14.4 Mbit/s
- with uplink maximum	0.384 Mbit/s	5.76 Mbit/s
Interfaces		
Number of electrical connections		
• for network components and terminal equipment	1	2
• for external antenna(s)	1	2
• for power supply	1	1
Design of electrical connection		
• for network components and terminal equipment		
• for external antenna(s)	SMA antenna socket (50 ohms)	SMA antenna socket (50 ohms)
• for power supply	Terminal block	Terminal block
Inputs/outputs		
Number of electrical connections		
• for digital input signals	1	1
• for digital output signals	1	1
Design of electrical connection		
• for digital input signals	Terminal block	Terminal block
• for digital output signals	Terminal block	Terminal block

SIMATIC S7-300

Communication

SCALANCE M87x UMTS routers

Technical specifications (continued)

Order No.	6GK5 873-0AA10-1AA2	6GK5 875-0AA10-1AA2
Product-type designation	SCALANCE M873	SCALANCE M875
WAN connection		
Type of mobile wireless network is supported GSM	Yes	Yes
Type of mobile wireless service is supported		
• GPRS	Yes	Yes
• eGPRS	Yes	Yes
Type of mobile wireless network is supported UMTS	Yes	Yes
Type of mobile wireless service is supported		
• HSDPA	Yes	Yes
• HSUPA	No	Yes
Operating frequency		
• for GSM transmission		
- 850 MHz	Yes	Yes
- 900 MHz	Yes	Yes
- 1800 MHz	Yes	Yes
- 1900 MHz	Yes	Yes
• for UMTS transmission		
- 800 MHz	No	Yes
- 850 MHz	Yes	Yes
- 900 MHz	No	No
- 1700 MHz	No	Yes
- 1900 MHz	Yes	Yes
- 2100 MHz	Yes	Yes
Type of GPRS time slot method Multislot Class 10	-	-
Supply voltage, current consumption, power loss		
Type of voltage of supply voltage	DC	DC
Supply voltage	24 V	24 V
• minimum	12 V	12 V
• maximum	30 V	30 V
Consumed current maximum	450 mA	450 mA
Active power loss typical	4 W	4 W
Permitted ambient conditions		
Ambient temperature		
• during operating	-20 ... +60 °C	-40 ... +75 °C
• during storage	-40 ... +70 °C	-40 ... +85 °C
Relative humidity at 25 °C during operating maximum	95 %	95 %
Protection class IP	IP20	IP20
Design, dimensions and weight		
Design	compact	compact
Depth	114 mm	114 mm
Height	99 mm	99 mm
Width	45 mm	45 mm
Net weight	280 g	280 g
Type of mounting	-	-
35 mm DIN rail mounting	-	-
Type of mounting	-	-

Technical specifications (continued)

Order No.	6GK5 873-0AA10-1AA2	6GK5 875-0AA10-1AA2
Product-type designation	SCALANCE M873	SCALANCE M875
Product properties, functions, components general		
Product function DynDNS client	Yes	Yes
Product functions management, configuration		
Product function		
• CLI	No	No
• web-based management	Yes	Yes
• MIB support	No	No
• TRAPs via email	No	No
Protocol is supported		
• Telnet	No	No
• HTTP	No	No
• HTTPS	Yes	Yes
Type of configuration	Web interface	Web interface
Product functions Diagnosis		
Product function		
• Statistics Packet Size	No	No
• Statistics packet type	No	No
• Error statistics	No	No
• SysLog	Yes	Yes
• Packet Filter Log	Yes	Yes
Product functions DHCP		
Product function		
• DHCP client	Yes	Yes
• DHCP server - internal network	Yes	Yes
Product functions Routing		
Router function		
• NAT (IP masquerading)	Yes	Yes
• Port Forwarding	Yes	Yes
• NAT traversal	Yes	Yes
• 1:1 NAT	Yes	Yes
• DNS cache	Yes	Yes
Product functions Security		
Design of the firewall		
Product function		
• Password protection	Yes	Yes
• packet filter	Yes	Yes
• Broadcast/Multicast/Unicast Limiter	-	-
• broadcast blocking	-	-
Suitability for installation Virtual Private Network	No	Yes
Product function with VPN connection	No	Yes
Number of possible connections for VPN connection	-	10
Number of network stations for internal network with VPN connection maximum	-	-
Type of authentication with Virtual Private Network PSK	No	Yes
Protocol will be supported IPsec tunnel and transport mode	No	Yes

SIMATIC S7-300

Communication

SCALANCE M87x UMTS routers

Technical specifications (continued)

Order No.	6GK5 873-0AA10-1AA2	6GK5 875-0AA10-1AA2
Product-type designation	SCALANCE M873	SCALANCE M875
Key length		
• with IPsec DES with Virtual Private Network	-	56 bit
• 1 with IPsec AES with Virtual Private Network	-	128 bit
• 2 with IPsec AES with Virtual Private Network	-	192 bit
• 3 with IPsec AES with Virtual Private Network	-	256 bit
Type of Internet key exchange with Virtual Private Network main mode	No	Yes
Key length with IPsec 3DES with Virtual Private Network	-	168 bit
Type of Internet key exchange with Virtual Private Network quick mode	No	Yes
Type of packet authentication with Virtual Private Network	-	
IETF profile with Virtual Private Network X.509v3 certificate	No	Yes
Product functions Time		
Router function NTP	Yes	Yes
Standards, specifications, approvals		
Standard		
• for EMC	-	-
• for EMC from FM	-	-
• for hazardous zone	-	-
• for safety of CSA and UL	-	-
• for hazardous area of CSA and UL	-	-
• for emitted interference	EN 55022 Class A	EN 55022 Class A
• for interference immunity	EN 61000-6-2	EN 61000-6-2
Verification of suitability	EN 61000-6-2	EN 61000-6-2
• CE mark	Yes	Yes
• C-Tick	-	-
• E1 approval	Yes	Yes
• e1 approval	Yes	Yes
• Railway application in accordance with EN 50155	No	Yes

Ordering data	Order No.	Order No.	
<p>SCALANCE M 87x UMTS router</p> <p>UMTS router for wireless IP communication between Industrial Ethernet-based programmable controllers via UMTS/GSM mobile radio networks; EGPRS Multislot Class 12</p> <ul style="list-style-type: none"> • SCALANCE M873¹⁾ with integral firewall; 1 x RJ45 port, 1 x antenna connection • SCALANCE M875¹⁾ with integral firewall and VPN with IPsec; 2 x RJ45 ports, 2 x antenna connections 	<p>6GK5 873-0AA10-1AA2</p> <p>6GK5 875-0AA10-1AA2</p>	<p>CP 343-1 Advanced</p> <p>For connecting the SIMATIC S7-300 CPU to Industrial Ethernet; 1 x 10/100/1000 Mbit/s; 2 x 10/100 Mbit/s (IE switch); RJ45 ports; TCP; UDP; ISO; PROFINET IO-Controller and Device, S7 communication (client + server); open communication (SEND/RECEIVE); S7 routing; IP configuration via DHCP/block; extended Web diagnostics; time synchronization; IP Access Control List; IP routing; FTP; e-mail; PROFINET CBA; C-Plug; mit Security (Firewall + VPN) und PROFEnergy (Controller + Device)</p>	<p>6GK7 343-1GX31-0XE0</p>
<p>Accessories</p> <p>IE FC RJ45 Plug 180</p> <p>RJ45 plug-in connector for Industrial Ethernet with a rugged metal enclosure and integrated insulation displacement contacts for connecting Industrial Ethernet FC installation cables; with 180° cable outlet; for network components and CPUs/CPUs with Industrial Ethernet interface</p> <ul style="list-style-type: none"> • 1 pack = 1 unit • 1 pack = 10 units • 1 pack = 50 units 	<p>6GK1 901-1BB10-2AA0</p> <p>6GK1 901-1BB10-2AB0</p> <p>6GK1 901-1BB10-2AE0</p>	<p>CP 443-1 Advanced</p> <p>for connecting the SIMATIC S7-400 CPU to Industrial Ethernet: 1 x 10/100/1000 Mbit/s; 4 x 10/100 Mbit/s (IE SWITCH); RJ45 ports; ISO; TCP; UDP; PROFINET IO controller, S7 communication; open communication (SEND/RECEIVE); S7 routing; IP configuration via DHCP/block; IP Access Control List; time synchronization; expanded Web diagnostics; Fast Startup; PROFEnergy support; IP routing; FTP; Web server; e-mail; PROFINET CBA; mit Security (Firewall/VPN)</p>	<p>6GK7 443-1GX30-0XE0</p>
<p>ANT794-4MR antenna</p> <p>Omnidirectional antenna for GSM (2G) and UMTS (3G) networks; weather-resistant for indoor and outdoor use; 5 m cable with fixed connection to antenna; SMA connector; including mounting bracket, screws, wall plugs</p>	<p>6NH9 860-1AA00</p>	<p>IE TP Cord RJ45/RJ45</p> <p>TP cable 4 x 2 with 2 RJ45 connectors</p> <ul style="list-style-type: none"> • 0.5 m • 1 m • 2 m • 6 m • 10 m 	<p>6XV1 870-3QE50</p> <p>6XV1 870-3QH10</p> <p>6XV1 870-3QH20</p> <p>6XV1 870-3QH60</p> <p>6XV1 870-3QN10</p>
<p>SCALANCE S Industrial Security Modules</p> <p>For protection of programmable controllers and automation networks, and for safeguarding of industrial communication; configuring tool and electronic manual on CD-ROM; German, English, French, Italian, Spanish</p> <ul style="list-style-type: none"> • SCALANCE S612 uses the stateful inspection firewall to protect network segments against unauthorized access; protects up to 32 devices up to 64 VPN tunnels simultaneously • SCALANCE S623 uses the stateful inspection firewall to protect network segments against unauthorized access; protects up to 64 devices and up to 128 VPN tunnels simultaneously; enhanced temperature range (-20 to +70 °C) 	<p>6GK5 612-0BA10-2AA3</p> <p>6GK5 623-0BA10-2AA3</p>		

¹⁾ Please note national approvals under www.siemens.com/wireless-approvals

SIMATIC S7-300

Communication

ASM 475

Overview



The ASM 475 is a low-cost module for connecting the MOBY D, U, SIMATIC RF200, RF300, RF600 and SIMATIC MV400 identification systems to the S7-300 and ET 200M.

5

Technical specifications

Order No.	6GT2 002-0GA10
Product-type designation	ASM 475 communications module
Suitability for installation	
Transmission rate at point-to-point connection serial maximum	115.2 kbit/s
Interfaces	
Design of interface for point-to-point connection	RS422
Number of readers connectable	2
Design of electrical connection	S7-300 backplane bus (according to the head module)
<ul style="list-style-type: none"> of the backplane bus of the PROFIBUS interface the Industrial Ethernet Interface for supply voltage 	Screw-type or spring-loaded terminals
Version of the interface to the reader for communication	Screw-type or spring-loaded terminals
Mechanical data	
Material	Noryl
Color	Anthracite
Supply voltage, current consumption, power loss	
Supply voltage for DC	
<ul style="list-style-type: none"> rated value minimum maximum 	24 V 20 V 30 V
Current consumed at 24 V DC	
<ul style="list-style-type: none"> without connected devices typical including connected devices maximum 	0.1 A 1 A
Permitted ambient conditions	
Ambient temperature	
<ul style="list-style-type: none"> during operating during storage during transport 	0 ... 60 °C -40 ... +70 °C -40 ... +70 °C
Protection class IP	
Resistance against shock	According to IEC 61131-2
Resistance against shock	150 m/s ²
Resistance against vibration	10 m/s ²

Order No.	6GT2 002-0GA10
Product-type designation	ASM 475 communications module
Design, dimensions and weight	
Width	40 mm
Height	125 mm
Depth	120 mm
Net weight	0.2 kg
Type of mounting	S7-300 rack
Cable length for RS 422 interface maximum	1000 m
Product properties, functions, components general	
Type of display	4 LEDs per reader connection, 2 LEDs for device status
Product function transponder file handler can be addressed	Yes
Protocol will be supported S7 communication	Yes
Product functions management, configuration	
Type of parameterization	Object manager, GSD
Type of programming	FB 45, FB 55, FC 56 (FC 45/55 with limited functionality)
Type of computer-mediated communication	acyclic communication
Standards, specifications, approvals	
Verification of suitability	CE, FCC, UL/CSA
Accessories	
Accessories	Front connector with screw-type or spring-loaded terminals

Ordering data	Order No.	Order No.
ASM 475 communications module For SIMATIC S7-300 and ET 200M, parameterizable	6GT2 002-0GA10	
Accessories Front connector (1 x per ASM 475) <ul style="list-style-type: none"> with screw terminals with spring-loaded terminals 	6ES7 392-1AJ00-0AA0 6ES7 392-1BJ00-0AA0	
MOBY U connecting cable pre-assembled, between the ASM 475 and reader, angled connector, PUR material, in the following lengths: 2 m 5 m 10 m 20 m 50 m	6GT2 091-4EH20 6GT2 091-4EH50 6GT2 091-4EN10 6GT2 091-4EN20 6GT2 091-4EN50	
MOBY D connecting cable pre-assembled, between ASM 475 and reader D1xS, 9-pole Sub-D plug, PUR material, CMG approved, suitable for cable carriers, in the following lengths: 5 m 20 m 50 m	6GT2 491-4EH50 6GT2 491-4EN20 6GT2 491-4EN50	
		SIMATIC RF200 / RF300 / RF600 / MV400 connecting cable pre-assembled, between the ASM 475 and RF200 / RF300 / RF600 / MV400, IP65, straight connector, PUR material, suitable for cable carriers, CMG approval, in the following lengths ¹⁾ : 2 m 5 m
		6GT2 891-4EH20 6GT2 891-4EH50
		Extension cable SIMATIC RF200 / RF300 / RF600 / MV400, PUR material, CMG approval, suitable for cable carriers, straight connector 2 m 5 m 10 m 20 m 50 m
		6GT2 891-4FH20 6GT2 891-4FH50 6GT2 891-4FN10 6GT2 891-4FN20 6GT2 891-4FN50
		DVD "RFID Systems Software & Documentation"
		6GT2 080-2AA20

¹⁾ The connecting cables can be extended using RF300 connecting cables of type 6GT2891-4Fxxx. These connecting cables are available in the lengths 2 m, 5 m, 10 m, 20 m and 50 m.

SIMATIC S7-300

SIPLUS communication

SIPLUS CP 340

Overview



- The low-cost, complete solution for serial communication over a point-to-point connection
- RS 232C (V.24) and RS 422/485 (X.27)
- Implemented protocols:
 - ASCII
 - 3964 (R) (not for RS 485)
 - Printer driver
- Simple parameterization using tool integrated in STEP 7

Note:

SIPLUS extreme products are based on Siemens Industry standard products. The contents listed here were taken from the respective standard products. SIPLUS extreme specific information was added.

SIPLUS CP 340 version	RS 232 (V.24)		RS 422/485 (X.27)
Order No.	6AG1 340-1AH02-2AE0	6AG1 340-1AH02-2AY0	6AG1 340-1CH02-2AE0
Order number based on	6ES7 340-1AH02-0AE0	6ES7 340-1AH02-0AE0	6ES7 340-1CH02-0AE0
Ambient temperature range	-25 ... +60 °C	-25 ... +60 °C	-25 ... +60 °C
Conformal coating	Coating of the printed circuit boards and the electronic components		
Technical data	The technical data of the standard product applies except for the ambient conditions.		
Conforms with standard for electronic equipment used on rolling stock (EN 50155, temperature T1, category 1).	No	Yes	No

Ambient conditions

Relative humidity	100%, condensation/frost permissible. No commissioning if condensation present.
Biologically active substances, compliance with EN 60721-3-3	Class 3B2 mold and fungal spores (excluding fauna). The supplied plug covers must remain in place over the unused interfaces during operation!
Chemically active substances, compliance with EN 60721-3-3	Class 3C4 incl. salt spray in accordance with EN 60068-2-52 (degree of severity 3). The supplied plug covers must remain in place over the unused interfaces during operation!
Mechanically active substances, compliance with EN 60721-3-3	Class 3S4 incl. sand, dust. The supplied plug covers must remain in place over the unused interfaces during operation!
Air pressure (depending on the highest positive temperature range specified)	1 080 ... 795 hPa (-1 000 ... +2 000 m), see ambient temperature range 795 ... 658 hPa (+2 000 ... +3 500 m) derating 10 K 658 ... 540 hPa (+3 500 ... +5 000 m) derating 20 K

For technical documentation on SIPLUS, see:
www.siemens.com/siplus-extreme

Ordering data

SIPLUS CP 340 communications processor

(extended temperature range and medial exposure)

- with one RS 232C interface (V.24)
- with one RS 232C interface (V.24); compliant with EN 50155
- with one RS 422/485 interface (X.27)

Order No.

- 6AG1 340-1AH02-2AE0**
- 6AG1 340-1AH02-2AY0**
- 6AG1 340-1CH02-2AE0**

Accessories

Order No.

See SIMATIC CP 340, page 5/160

Overview



- For fast, high-performance serial data exchange via point-to-point coupling
- Two versions with different physical transmission characteristics:
 - RS 232C (V.24),
 - RS 422/RS 485 (X.27)
- Implemented protocols: ASCII, 3964 (R), RK 512, customized protocols (can be reloaded)
- Simple parameterization using tool integrated in STEP 7

Note:

SIPLUS extreme products are based on Siemens Industry standard products. The contents listed here were taken from the respective standard products. SIPLUS extreme specific information was added.

SIPLUS CP 341	RS 232C interface (V.24)	RS 422/485 (X.27) interface
Order No.	6AG1 341-1AH02-7AE0	6AG1 341-1CH02-7AE0
Order No. based on	6ES7 341-1AH02-0AE0	6ES7 341-1CH02-0AE0
Ambient temperature range	-25 ... +70 °C	-25 ... +70 °C
Conformal coating	Coating of the printed circuit boards and the electronic components	
Technical data	The technical data of the standard product applies except for the ambient conditions.	
Ambient conditions		
Relative humidity	100%, condensation/frost permissible. No commissioning if condensation present.	
Biologically active substances, compliance with EN 60721-3-3	Class 3B2 mold and fungal spores (excluding fauna). The supplied plug covers must remain in place over the unused interfaces during operation!	
Chemically active substances, compliance with EN 60721-3-3	Class 3C4 incl. salt spray in accordance with EN 60068-2-52 (degree of severity 3). The supplied plug covers must remain in place over the unused interfaces during operation!	
Mechanically active substances, compliance with EN 60721-3-3	Class 3S4 incl. sand, dust. The supplied plug covers must remain in place over the unused interfaces during operation!	
Air pressure (depending on the highest positive temperature range specified)	1 080 ... 795 hPa (-1 000 ... +2 000 m), see ambient temperature range 795 ... 658 hPa (+2 000 ... +3 500 m) derating 10 K 658 ... 540 hPa (+3 500 ... +5 000 m) derating 20 K	

For technical documentation on SIPLUS, see:
www.siemens.com/siplus-extreme

Ordering data	Order No.	Accessories	Order No.
SIPLUS CP 341 communications processor (extended temperature range and medial exposure) with RS 232C interface (V.24) with RS 422/485 (X.27) interface	6AG1 341-1AH02-7AE0 6AG1 341-1CH02-7AE0		See SIMATIC CP 341, page 5/162

SIMATIC S7-300

SIPLUS communication

SIPLUS CP 343-1 Lean

Overview



ISO	TCP/UDP	PN	MRP	IT	IP-R	PG/OP	S7/S5
	●	●	●			●	●

- Interface for the SIMATIC S7-300 to Industrial Ethernet (not for SINUMERIK)
 - 2 x RJ45 interface for 10/100 Mbit/s full/half duplex connection (with autosensing for automatic switchover and autocrossover function)
 - Integral 2-port real-time switch ERTEC
 - Multi-protocol operation with TCP and UDP transport protocol and PROFINET I/O
 - Keep Alive function
- Communication services:
 - Open communication (TCP/IP and UDP):
 - PG/OP communication
 - S7 communication (server)
 - PROFINET IO device
- Multicast for UDP
- Remote programming and initial commissioning is possible over Industrial Ethernet
- IT communication
 - Web function
- Integration into network management through SNMP
- Configuration with STEP 7
- Cross-network programming device/operator panel communication through S7 routing
- Diagnostics possibilities in STEP 7 and via web browser

Note:

SIPLUS extreme products are based on Siemens Industry standard products. The contents listed here were taken from the respective standard products. SIPLUS extreme-specific information was added.

SIPLUS CP 343-1 Lean		
Order number	6AG1 343-1CX10-2XE0	6AG1 343-1CX10-4XE0
Order number based on	6GK7 343-1CX10-0XE0	
Ambient temperature range	-25 ... +60 °C	0 ... +60 °C
Conformal coating	Coating of the printed circuit boards and the electronic components	
Technical data	The technical data of the standard product applies except for the ambient conditions.	
Ambient conditions		
Relative humidity	100%, condensation/frost permissible. No commissioning if condensation present.	
Biologically active substances, compliance with EN 60721-3-3	Class 3B2 mold spores, fungal spores (excluding fauna). The supplied plug covers must remain in place over the unused interfaces during operation!	
Chemically active substances, compliance with EN 60721-3-3	Class 3C4 incl. salt spray in accordance with EN 60068-2-52 (degree of severity 3). The supplied plug covers must remain in place over the unused interfaces during operation!	
Mechanically active substances, compliance with EN 60721-3-3	Class 3S4 incl. sand, dust. The supplied plug covers must remain in place over the unused interfaces during operation!	
Air pressure (depending on the highest positive temperature range specified)	1080 ... 795 hPa (-1000 ... +2000 m) see ambient temperature range 795 ... 658 hPa (+2000 ... +3500 m) derating 10 K 658 ... 540 hPa (+3500 ... +5000 m) derating 20 K	

For technical documentation on SIPLUS, see:
www.siemens.com/siplus-extreme

Ordering data	Order No.
SIPLUS CP 343-1 Lean communications processor (extended temperature range and medial exposure) For connecting SIMATIC S7-300 to Industrial Ethernet through TCP/IP and UDP, Multicast, S7 communication, open communication (SEND/RECEIVE), FETCH/WRITE, PROFINET IO device, integral 2-port switch ERTEC, comprehensive diagnostics facilities, module replacement without PG, SNMP, initial commissioning over LAN; with electronic manual on CD-ROM	
Ambient temperature 0 ... +60 °C	
Ambient temperature -25 ... +60 °C	
Accessories	See SIMATIC CP 343-1 Lean communications processor, page 5/175

Overview



ISO	TCP/UDP	PN	MRP	IT	IP-R	PG/OP	S7/S5
●	●	●	●			●	●

- Connection of SIMATIC S7-300/SINUMERIK 840D powerline to Industrial Ethernet
 - 2 x RJ45 interface for 10/100 Mbit/s full/half-duplex connection with auto-sensing/auto-negotiation and auto-crossover function
 - Integrated 2-port real-time switch ERTEC
 - Multi-protocol operation with ISO, TCP, UDP transport protocol and PROFINET IO
 - Adjustable keep alive function
- Communication services:
 - Open communication (ISO, TCP/IP, and UDP)
 - PROFINET IO-Controller or PROFINET IO-Device
 - PG/OP communication: Cross-network by means of S7 routing
 - S7 communication (client, server, multiplexing)
- Media redundancy (MRP); within an Ethernet network with ring topology, the CP supports the media redundancy procedure MRP (V2.2 or higher).
- Multicast for UDP
- IP address assignment via DHCP, simple PC tool or via the user program (e.g. HMI)
- Access protection via configurable access list
- Remote programming and commissioning via Industrial Ethernet
- Configuration with STEP 7
- Automatic setting of CPU clock setting over Ethernet with NTP or SIMATIC procedure
- Web diagnostics
- Integration in network management systems via SNMP (MIB2 diagnostics information)
- Diagnostics possibilities in STEP 7 and via web browser

Note:

SIPLUS extreme products are based on Siemens Industry standard products. The contents listed here were taken from the respective standard products. SIPLUS extreme-specific information was added.

SIPLUS CP 343-1

Order number	6AG1 343-1EX30-4XE0	6AG1 343-1EX30-7XE0
Order number based on	6GK7 343-1EX30-0XE0	6GK7 343-1EX30-0XE0
Ambient temperature range	0 ... +60 °C	-25 ... +70 °C
Conformal coating	Coating of the printed circuit boards and the electronic components	
Technical data	The technical data of the standard product applies except for the ambient conditions.	

Ambient conditions

Relative humidity	100%, condensation/frost permissible. No commissioning if condensation present.
Biologically active substances, compliance with EN 60721-3-3	Class 3B2 mold spores, fungal spores (excluding fauna). The supplied plug covers must remain in place over the unused interfaces during operation!
Chemically active substances, compliance with EN 60721-3-3	Class 3C4 incl. salt spray in accordance with EN 60068-2-52 (degree of severity 3). The supplied plug covers must remain in place over the unused interfaces during operation!
Mechanically active substances, compliance with EN 60721-3-3	Class 3S4 incl. sand, dust. The supplied plug covers must remain in place over the unused interfaces during operation!
Air pressure (depending on the highest positive temperature range specified)	1080 ... 795 hPa (-1000 ... +2000 m) see ambient temperature range 795 ... 658 hPa (+2000 ... +3500 m) derating 10 K 658 ... 540 hPa (+3500 ... +5000 m) derating 20 K

For technical documentation on SIPLUS, see:
www.siemens.com/siplus-extreme

SIMATIC S7-300

SIPLUS communication

SIPLUS CP 343-1

Ordering data

Order No.

SIPLUS CP 343-1 communications processor

(extended temperature range and medial exposure)

for connecting SIMATIC S7-300 to Industrial Ethernet via ISO and TCP/IP; PROFINET IO-Controller or PROFINET IO-Device, MRP, integrated 2-port switch ERTEC; S7 communication, open communication (SEND/RECEIVE), FETCH/WRITE with or without RFC 1006, multicast, DHCP, CPU clock set via SIMATIC procedure and NTP, diagnostics, SNMP, access control via IP access list, initialization over LAN 10 /100 Mbit/s; with electronic manual on DVD

Ambient temperature 0 ... +60 °C

Ambient temperature -25 ... +70 °C

6AG1 343-1EX30-4XE0

6AG1 343-1EX30-7XE0

Accessories

Order No.

See SIMATIC CP 343-1 communications processor, page 5/178

Overview



ISO	TCP/UDP	PN	MRP	IT	IP-R	PG/OP	S7/S5
●	●	●	●	●	●	●	●

- Connection of SIMATIC S7-300/SINUMERIK 840D powerline to Industrial Ethernet
 - Multi-protocol operation with TCP and UDP transport protocol
 - Adjustable keep alive function
- Two separate interfaces (integrated network separation):
 - Gigabit interface with one RJ45 port with 10/100/1000 Mbit/s full/half-duplex with auto-sensing capability
 - PROFINET interface with two RJ45 ports with 10/100 Mbit/s full/half-duplex with auto-sensing and auto-crossover functionality via integrated 2-port switch
- Communication services via both interfaces:
 - Open communication (TCP/IP and UDP): Multicast with UDP, including routing between both interfaces
 - PG/OP communication:
 - Cross-network by means of S7 routing
 - S7 communication (client, server, multiplexing) including routing between both interfaces
 - IT communication:
 - HTTP communication supports access to process data via own Web pages;
 - e-mail client function, sending of e-mails directly from user program;
 - FTP communication supports program-controlled FTP client communication;
 - access to data blocks through FTP server
- Communication services via PROFINET interfaces:
 - PROFINET IO-Controller and IO-Device with real-time properties (RT and IRT)¹⁾
 - PROFINET CBA
 - IP address assignment via DHCP, simple PC tool or via program block (e.g. for HMI)
 - Configuration with STEP 7
- Media redundancy (MRP); within an Ethernet network with ring topology, the CP supports the media redundancy procedure MRP (V2.2 or higher).
- Access protection by means of configurable IP access list

- Module replacement without programming device; all information is stored on the C-PLUG (also file system for IT functions)
 - Extensive diagnostic functions for all modules in the rack
 - IT communication
 - Web function
 - E-mail function
 - FTP
 - Integration into network management systems through the support of SNMP V1 MIB-II
- ¹⁾ Possible combinations in parallel mode:
- IO-Controller with IRT and IO-Device with RT
 - IO-Controller with RT and IO-Device using IRT

Note:

SIPLUS extreme products are based on Siemens Industry standard products. The contents listed here were taken from the respective standard products. SIPLUS extreme-specific information was added.

SIPLUS CP 343-1 Advanced	
Order number	6AG1 343-1GX30-4XE0
Order number based on	6GK7 343-1GX30-0XE0
Ambient temperature range	0 ... +60 °C
Conformal coating	Coating of the printed circuit boards and the electronic components
Technical data	The technical data of the standard product applies except for the ambient conditions.
Ambient conditions	
Relative humidity	100%, condensation/frost permissible. No commissioning if condensation present.
Biologically active substances, compliance with EN 60721-3-3	Class 3B2 mold spores, fungal spores (excluding fauna). The supplied plug covers must remain in place over the unused interfaces during operation!
Chemically active substances, compliance with EN 60721-3-3	Class 3C4 incl. salt spray in accordance with EN 60068-2-52 (degree of severity 3). The supplied plug covers must remain in place over the unused interfaces during operation!
Mechanically active substances, compliance with EN 60721-3-3	Class 3S4 incl. sand, dust. The supplied plug covers must remain in place over the unused interfaces during operation!
Air pressure (depending on the highest positive temperature range specified)	1080 ... 795 hPa (-1000 ... +2000 m) see ambient temperature range 795 ... 658 hPa (+2000 ... +3500 m) derating 10 K 658 ... 540 hPa (+3500 ... +5000 m) derating 20 K

For technical documentation on SIPLUS, see:
www.siemens.com/siplus-extreme

SIMATIC S7-300

SIPLUS communication

SIPLUS CP 343-1 Advanced

Ordering data

Order No.

SIPLUS CP 343-1 Advanced communications processor

6AG1 343-1GX30-4XE0

(medial exposure)

for connecting the SIMATIC S7-300 to Industrial Ethernet, PROFINET IO-Controller and IO-Device with RT and IRT, MRP, PROFINET CBA, TCP/IP and UDP, S7 communication, open communication (SEND/RECEIVE), FETCH/WRITE with or without RFC 1006, diagnostics extensions, multicast, Web server, HTML diagnostics, FTP server, FTP client, e-mail client, CPU clock set via SIMATIC procedure and NTP, access control via IP access List, SNMP, DHCP, initialization over LAN 10/100 Mbit/s; with electronic manual on DVD; C-PLUG included

Order No.

Accessories

See SIMATIC CP 343-1 Advanced communications processor, page 5/183

Overview



- SINAUT communications module SIPLUS TIM for SIMATIC S7-300 for use in a wide area network (WAN)
- IP communication via secure VPN (virtual private network) using the Internet
- Wireless communication via GPRS router, GPRS modem, or radio devices
- Wired communication via Ethernet, DSL, dialup modems or dedicated line modem
- Complete migration of existing wireless, dedicated line and dial-up technology to IP-based network
- Message frame memory for seamless recording of data
- Simple configuration and operation without specialist IT knowledge

Note:

SIPLUS extreme products are based on Siemens Industry standard products. The contents listed here were taken from the respective standard products. SIPLUS extreme-specific information was added.

SIPLUS TIM 3V-IE	
Order number	6AG1 800-3BA00-7AA0
Order number based on	6NH7 800-3BA00
Ambient temperature range	-25 ... +70 °C
Conformal coating	Coating of the printed circuit boards and the electronic components
Technical data	The technical data of the standard product applies except for the ambient conditions.
Ambient conditions	
Relative humidity	100%, condensation/frost permissible. No commissioning if condensation present.
Biologically active substances, compliance with EN 60721-3-3	Class 3B2 mold spores, fungal spores (excluding fauna). The supplied plug covers must remain in place over the unused interfaces during operation!
Chemically active substances, compliance with EN 60721-3-3	Class 3C4 incl. salt spray in accordance with EN 60068-2-52 (degree of severity 3). The supplied plug covers must remain in place over the unused interfaces during operation!
Mechanically active substances, compliance with EN 60721-3-3	Class 3S4 incl. sand, dust. The supplied plug covers must remain in place over the unused interfaces during operation!
Air pressure (depending on the highest positive temperature range specified)	1080 ... 795 hPa (-1000 ... +2000 m) see ambient temperature range 795 ... 658 hPa (+2000 ... +3500 m) derating 10 K 658 ... 540 hPa (+3500 ... +5000 m) derating 20 K

For technical documentation on SIPLUS, see:
www.siemens.com/siplus-extreme

Ordering data

SIPLUS TIM 3V-IE communications module
 With an RS232 interface for SINAUT communication via a conventional WAN or an IP-based network (WAN or LAN)

Order No.

6AG1 800-3BA00-7AA0

Accessories

Order No.

See TIM 3V-IE communications module, page 5/192

SIMATIC S7-300

SIPLUS communication

SIPLUS TIM 4R-IE for WAN and Ethernet

Overview



SINAUT communications module SIPLUS TIM with four interfaces for SIMATIC S7-300 or as self-contained unit for the S7-400 for use in a wide area network (WAN)

- For universal use in a SINAUT station, node station and control center
- Internet communication via integrated MSC-VPN tunnel with direct connection to DSL router or operation via IPsec VPN with additional SIMATIC NET components
- Wireless communication via GPRS router, GPRS modem, or radio devices
- Wired communication via Ethernet, DSL, dialup modems or dedicated line modem
- Complete migration of existing wireless, dedicated line and dial-up technology to IP-based network
- Message frame memory for seamless recording of data and support of redundant communication paths
- Simple configuration and operation without specialist IT knowledge

Note:

SIPLUS extreme products are based on Siemens Industry standard products. The contents listed here were taken from the respective standard products. SIPLUS extreme-specific information was added.

SIPLUS TIM 4R-IE	
Order number	6AG1 800-4BA00-7AA0
Order number based on	6NH7 800-4BA00
Ambient temperature range	-25 ... +70 °C
Conformal coating	Coating of the printed circuit boards and the electronic components
Technical data	The technical data of the standard product applies except for the ambient conditions.

Ambient conditions

Relative humidity	100%, condensation/frost permissible. No commissioning if condensation present.
Biologically active substances, compliance with EN 60721-3-3	Class 3B2 mold spores, fungal spores (excluding fauna). The supplied plug covers must remain in place over the unused interfaces during operation!
Chemically active substances, compliance with EN 60721-3-3	Class 3C4 incl. salt spray in accordance with EN 60068-2-52 (degree of severity 3). The supplied plug covers must remain in place over the unused interfaces during operation!
Mechanically active substances, compliance with EN 60721-3-3	Class 3S4 incl. sand, dust. The supplied plug covers must remain in place over the unused interfaces during operation!
Air pressure (depending on the highest positive temperature range specified)	1080 ... 795 hPa (-1000 ... +2000 m) see ambient temperature range 795 ... 658 hPa (+2000 ... +3500 m) derating 10 K 658 ... 540 hPa (+3500 ... +5000 m) derating 20 K

For technical documentation on SIPLUS, see:
www.siemens.com/siplus-extreme

Ordering data

SIPLUS TIM 4R-IE communications module

With two combined RS232/RS485 interfaces for SINAUT communication via conventional WANs and two RJ45 interfaces for SINAUT communication via IP-based networks (WAN or LAN)

Order No.

6AG1 800-4BA00-7AA0

Accessories

Order No.

See TIM 4R-IE communications module, page 5/198

Overview



- For the simple and user-friendly connection of sensors and actuators to the S7-300 I/O modules
- For maintaining the wiring when replacing modules ("permanent wiring")
- With mechanical coding to avoid errors when replacing modules

Ordering data

Order No.

Front connectors

20-pin, with screw contacts

- 1 unit
- 100 units

6ES7 392-1AJ00-0AA0

6ES7 392-1AJ00-1AB0

20-pin, with spring-loaded contacts

- 1 unit
- 100 units

6ES7 392-1BJ00-0AA0

6ES7 392-1BJ00-1AB0

40-pin, with screw contacts

- 1 unit
- 100 units

6ES7 392-1AM00-0AA0

6ES7 392-1AM00-1AB0

40-pin, with spring-loaded contacts

- 1 unit
- 100 units

6ES7 392-1BM01-0AA0

6ES7 392-1BM01-1AB0

Front door, elevated design

6ES7 328-0AA00-7AA0

e.g. for 32 channel modules;
enables connection of
1.3 mm²/16 AWG wires

Front door, higher version, for F-modules

6ES7 328-7AA10-0AA0

For F-modules; for connecting
1.3 mm²/16 AWG wires;
wiring diagram and labels in yellow

SIMATIC S7-300

Connection methods

SIMATIC TOP connect for SIMATIC S7-300 and ET 200M

Overview

Wiring of SIMATIC S7 I/O modules with the sensors/actuators is a significant factor with respect to time/cost overhead, configuring, control cabinet installation, procurement and ease of service.

With SIMATIC TOP connect system cabling, it is simple and quick to establish a reliable connection for your SIMATIC S7-300/400.

With the TIA Selection Tool, a mouse click is all that is required to configure the connection from the SIMATIC S7 module to the I/O. The program automatically checks for plausibility and generates a parts list for the selected connection components that can then be ordered in the Industry Mall.

Further information can be found on the Internet at

www.siemens.com/tia-selection-tool

Design

Two cabling variants are available for the most diverse control cabinet concepts:

Fully modular connection

Each component is individually inserted.

The system consists of:

- Front connector module
- Connecting cable
- Connection modules in the following versions: Basic module, signal module and function module

Connection errors are thus practically excluded and installation overhead is minimized. Systematic connection of the SIMATIC system. The assembly overhead for the connecting cables is drastically reduced as cables sold by the meter that are either pre-assembled or that can be assembled easily can be used.

Flexible connection

Consisting of:

- Front connector with screw-type or crimp connection
- Front connector with fixed single cores
- Single cores also available with UL/CSA-certified cores

The blue wires are numbered sequentially and can be routed direct to each element in the control cabinet. The numbering of the single cores corresponds to the coding of the front connector contacts.

In comparison to conventional single wiring, there is a cost saving of 50% for assembly, since the single cores that have already been checked on the connector are fixed.

Thus no complex pre-assembly of up to two times 46 single cores per module is necessary.

SIMATIC S7-300

Connection methods

SIMATIC TOP connect for SIMATIC S7 Fully modular connection

Overview



The fully modular connection is the standard connection for the SIMATIC S7-300/400. The fully modular connection allows the peripherals to be conveniently and quickly connected to the SIMATIC S7-300/400 without errors.

Benefits

- Easy plugging in of front connector module, connecting cable and connection module
- Fast and low-cost wiring
- Supply voltage connectable to front connector module or connection module for digital and analog signals
- Reduction in wiring errors, clear control cabinet wiring
- Distribution of digital signals by byte or by double-byte
- Each component can be replaced individually
- Every cable length can be configured without cutting, or pre-assembled cables can be used

Design

Front connector module

Modified front connectors, called front connector modules, are available for connecting to the module. These are plugged into the module to be wired instead of the front connector. The front connector modules are available in many different versions. For the SIMATIC S7-300 and SIMATIC S7-400, digital or analog. The connecting cables are plugged into these front connector modules.

Connecting cable

The connecting cable is available in two different versions.

As a pre-assembled 16-pole round cable (shielded or unshielded) up to a length of 5 m, or the 16-pole round-sheath ribbon cable (with or without shield), which can be easily assembled by the user, or as 2 x 16-pole round-sheath ribbon cables (without shield).

When assembled, there are one or two insulation displacement connectors (female ribbon connectors) at both ends of the cable.

The round-sheath ribbon cable is assembled by the user with the aid of pliers (to be ordered separately). The cable transmits 8 or 2 x 8 channels over a distance of up to 30 m.

The connecting cable connects the front connector module with the connection module.

Connection module

The system has digital and analog connection modules for connecting the I/O signals. These are snapped onto the standard mounting rail.

The connection modules are available for two connection methods: with spring-loaded or screw-type terminals

Basic module:

Connection modules with basic functionality for getting the signal from the field to the module or from the module to the field quickly and easily. For digital or analog signals.

Signal module:

Expands the digital basic module with LEDs for signaling the active high signal. This makes commissioning easier for you, and you always have an overview of the signal states of your I/O. One LED signals the availability of the supply voltage.

Function module:

Digital connection modules that are fitted with relays or optocouplers.

If other voltage or power levels are required in the field, the connection module for output signals TPRo or TPOo is used. For the TPRo connection module, relays are used for the implementation. For the TPOo connection module, optocouplers are used for the implementation. This converts the 24 V DC output signal simply and reliably to another voltage or power level. If 230 V AC input signals have to be transmitted to the controller in the field, a connection module with relay TPRi is available that simply converts the 230 V AC signal to 24 V DC. This means that there is always the same voltage level on the module side.

Use with optocouplers for the TPRo relay modules

If higher switching frequencies of the relay connection module are required for the output signals, the relay can simply be replaced with an optocoupler (note technical specifications) in order to increase the switching frequency here.

Shield plate

The shield plate is latched onto the connection module for 3-core initiators or optionally onto the connection module for analog signals and then snapped onto the mounting rail with the connection module. With the terminal elements, optimal shield connection is achieved between the shielded round-sheath ribbon cable or the shielded field cables and the grounded mounting rail.

SIMATIC S7-300

Connection methods

SIMATIC TOP connect for SIMATIC S7
Fully modular connection

Design (continued)

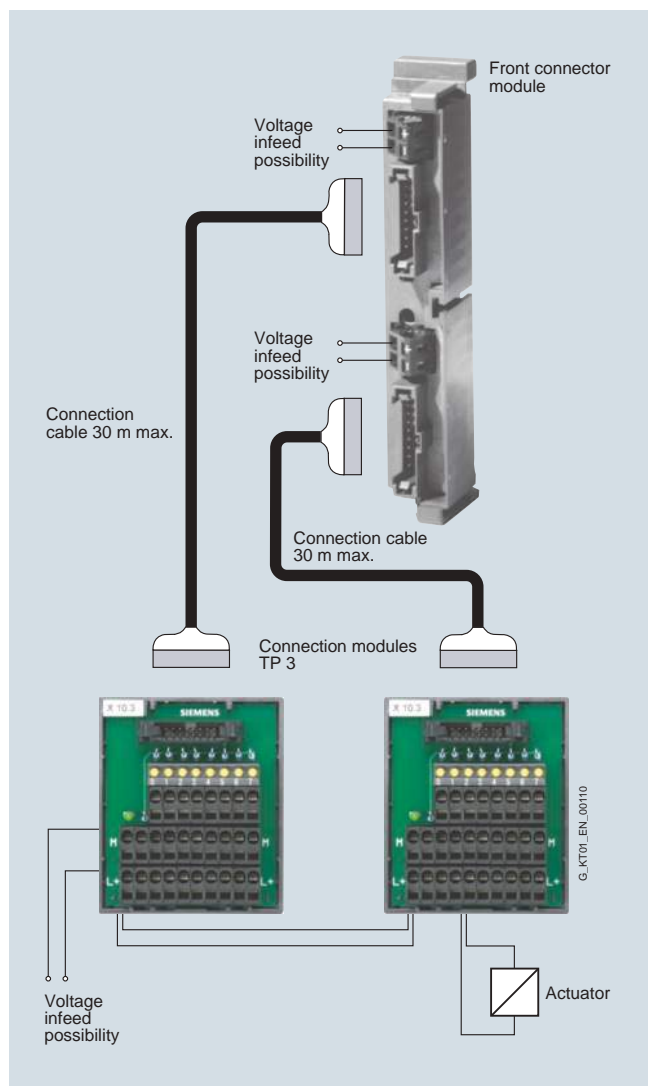

Design of the fully modular connection (16-channel in example)

Technical specifications Front connector module

Rated operating voltage	24 V DC
Max. permissible operating voltage	60 V DC
Max. permissible continuous current • per connector pin	1 A
Max. permissible summation current	4 A/byte
Permissible ambient temperature	0 to + 60°C
Test voltage	0.5 kV, 50 Hz, 60 sec.
Air gaps and creepage distances	IEC 664 (1980), IEC 664 A (1981), in accordance with DIN VDE 0110 (01.89), overvoltage class II, pollution degree 2

Wiring rules for the front connector modules

Front connector module SIMATIC TOP connect,
connection for potential infeed

	Spring connection	Screw connection
Modules up to 4 connections		
Connectable cable cross-sections		
• solid cables	No	
• flexible cables with/without wire end ferrule	0,25 to 1.5 mm ²	
Number of wires per connection	1 or a combination of 2 conductors up to 1.5 mm ² (total) in a common wire end ferrule	
Max. diameter of the cable insulation	3.1 mm	
Stripping length of the cables		
• without insulating collar	6 mm	
• with insulating collar	-	
Wire-end ferrules in acc. with DIN 46228		
• without insulating collar	Form A; 5 to 7 mm long	
• with insulating collar 0.25 to 1.0 mm ²	-	
• with insulating collar 1.5 mm ²	-	
Blade width of the screwdriver	3.5 mm (cylindrical shape)	
Tightening torque for connecting the cables	-	0.4 to 0.7 Nm

Front connector module SIMATIC TOP connect,
connection for potential infeed

	Spring connection	Screw connection
Modules up to 8 connections		
Connectable cable cross-sections		
• solid cables	No	
• flexible cables with/without wire end ferrule	0.25 to 0.75 mm ²	
Number of cables per connection	1 or a combination of 2 wires up to 0.75 mm ² (total) in a common wire end ferrule	
Max. diameter of the cable insulation	2.0 mm	
Stripping length of the cables		
• without insulating collar	6 mm	
• with insulating collar	-	
Wire-end ferrules in acc. with DIN 46228		
• without insulating collar	Form A; 5 to 7 mm long	
• with insulating collar 0.25 to 1.0 mm ²	-	
• with insulating collar 1.5 mm ²	-	
Blade width of the screwdriver	3.5 mm (cylindrical shape)	
Tightening torque for connecting the cables	-	0.4 to 0.7 Nm

SIMATIC S7-300

Connection methods

SIMATIC TOP connect for SIMATIC S7 Fully modular connection

Technical specifications Connecting cable

Technical data of connecting cable from SIMATIC S7 to connection module	
Operating voltage	60 V DC
Continuous current per signal conductor	1 A
Max. summation current	4 A/byte
Operating temperature	0 to +60°C
Outer diameter of pre-assembled round cable in mm, unshielded/shielded	Approx. 6.5/7.0
Outer diameter of round-sheath ribbon cable in mm, 16-pole/2 x 16-pole	Approx. 9.5/11.5

Technical specifications Basic module

Connection module TP1, TP3 and TPK	
Max. operating voltage	60 V DC
Continuous current per signal	1 A
Max. summation current (voltage infeed)	4 A/byte
Operating temperature	0 to + 60°C
Mounting position	Any
Air gaps and creepage distances	IEC Report 664, IEC 664 A, IEC 1131 T2, CSA C22.2 No 142 UL 508, VDE 0160 (12.90), overvoltage category II, pollution degree 3
Dimensions (W x H x D) in mm	
• 1-wire connection 6ES7924-0AA10-0A_0	Approx. 55 x 43.2 x 63
• for 3-wire initiators 6ES7924-0CA10-0A_0	Approx. 68 x 43.2 x 80
• for 2 x 8 signals 6ES7924-1AA10-0A_0	Approx. 100 x 43.2 x 80

Connection module TP2	
Max. operating voltage	60 V DC
Continuous current signal conductor	2 A
Operating temperature	0 to + 60°C
Mounting position	Any
Air gaps and creepage distances	IEC Report 664, IEC 664 A, IEC 1131 T2, CSA C22.2 No 142 UL 508, VDE 0160 (12.90), overvoltage category II, pollution degree 3
Dimensions (W x H x D) in mm	
• for 2 ampere modules 6ES7924-0BB10-0A_0	Approx. 68 x 43.2 x 80

Connection module TPA	
Max. operating voltage	60 V DC
Continuous current signal conductor	1 A
Operating temperature	0 to + 60°C
Mounting position	Any
Air gaps and creepage distances	IEC Report 664, IEC 664 A, IEC 1131 T2, CSA C22.2 No 142 UL 508, VDE 0160 (12.90), overvoltage category II, pollution degree 3
Dimensions (W x H x D) in mm	
• for 2 analog modules 6ES7924-0CC10-0A_0	Approx. 68 x 43.2 x 80

Wiring rules for the connection modules

Connection module TPA, TP1, TP2, TP3, TPK		
	Spring connection	Screw connection
Connectable cable cross-sections		
• solid cables	No	
• flexible cables without wire end ferrule	0.5 to 2.5 mm ²	
• flexible cables with wire end ferrule in accordance with DIN 46228/1	0.5 to 1.5 mm ²	0.5 to 2.5 mm ² (2.5 mm ² with a crimp in accordance with EN 60947-1)
• flexible cables with wire end ferrule and plastic collar in accordance with DIN 46228/4	0.5 to 1.5 mm ²	
Number of cables per connection	1 or a combination of 2 cables up to the cross-sections specified above (total) in a shared wire end ferrule	
Blade width of the screwdriver	3.5 mm (cylindrical shape)	
Tightening torque for connecting the cables	-	0.4 to 0.7 Nm

Technical specifications Signal module

Connection module TP1, TP3 and TPK with LED	
Max. operating voltage	24 V DC
Continuous current per signal	1 A
Max. summation current (voltage infeed)	4 A/byte
Operating temperature	0 to + 60 °C
Mounting position	Any
Air gaps and creepage distances	IEC Report 664, IEC 664 A, IEC 1131 T2, CSA C22.2 No 142 UL 508, VDE 0160 (12.90), overvoltage category II, pollution degree 3
Dimensions (W x H x D) in mm	
• 1-wire connection with LED 6ES7924-0AA10-0B_0	Approx. 55 x 43.2 x 63
• for 3-wire initiators with LED 6ES7924-0CA10-0B_0	Approx. 68 x 43.2 x 80
• for 2 x 8 signals with LED 6ES7924-1AA10-0B_0	Approx. 100 x 43.2 x 80

Connection module TP2 with LED	
Max. operating voltage	24 V DC
Continuous current per signal conductor	2 A
Operating temperature	0 to + 60 °C
Mounting position	Any
Air gaps and creepage distances	IEC Report 664, IEC 664 A, IEC 1131 T2, CSA C22.2 No 142 UL 508, VDE 0160 (12.90), overvoltage category II, pollution degree 3
Dimensions (W x H x D) in mm	
• for 2-ampere modules with LED 6ES7924-0BB10-0B_0	Approx. 68 x 43.2 x 80

SIMATIC S7-300

Connection methods

SIMATIC TOP connect for SIMATIC S7
Fully modular connection

Technical specifications Signal module (continued)

Wiring rules for the connection modules

Connection module TP1 LED, TP2 LED, TP3 LED		
	Spring connection	Screw connection
Connectable cable cross-sections		
<ul style="list-style-type: none"> solid cables flexible cables without wire end ferrule flexible cables with wire end ferrule in accordance with DIN 46228/1 	No 0.5 to 2.5 mm ² 0.5 to 1.5 mm ²	0.5 to 2.5 mm ² (2.5 mm ² with a crimp in accordance with EN 60947-1)
<ul style="list-style-type: none"> flexible cables with wire end ferrule and plastic collar in accordance with DIN 46228/4 	0.5 to 1.5 mm ²	
Number of wires per connection	1 or a combination of 2 conductors up to the cross-sections specified above (total) in a shared wire end ferrule	
Blade width of the screwdriver	3.5 mm (cylindrical shape)	
Tightening torque for connecting the cables	-	0.4 to 0.7 Nm

Technical specifications Function module

Connection module with relay for outputs (TPRo)	
Energizing side	
Operating voltage for coil	24 V DC
Input circuit	Reverse polarity protection and freewheeling diodes
Contact side	
Number of relay outputs	8 (NO contacts)
Contact design	Single contact, 1 NO contact
Switching capacity (resistive load)	max. 4 A/250 V AC max. 3 A/30 V DC max. 0.6 A/48 V DC max. 0.4 A/60 V DC recommended minimum load ≥ 10 mA
Switching frequency	20 cycles/minute
Service life	
<ul style="list-style-type: none"> Mechanical Electrical 	5 x 10 ⁶ switching cycles 3 x 10 ⁴ operating cycles at 230 V AC/2 A/ $\cos \gamma = 1$
Operating temperature	0 ... +60 °C
Mounting position	Any
Clearance and creepage distances	Basic standard IEC 60664-1; UL 508; Cul (Reference CSA C22.2 No. 142) Overvoltage category III Pollution degree 2
Dimensions (W x H x D) in mm	
6ES7924-0BD10-0B_0	Approx. 100 x 45 x 80

Connection module with optocoupler for outputs (TPOo)	
Input data	
Power supply	
Potential connection (L1/M1)	24 V DC (20.4 ... 28.8 V DC)
Status indicator "L1"	Green LED
Switching inputs	
Number	8 channels (channel 0 ... 7) with reverse polarity protection

Connection module with optocoupler for outputs (TPOo)	
Input voltage "off"	0 V DC (0 ... 5 V DC)
Input voltage "on"	24 V DC (15 ... 28.8 V DC)
Input current	min. 5 mA with 20 V DC, per channel
Status indicator "on"	Green LED per channel
Output data	
Power supply	
Operating voltage U_B (L2/M2, L3/M3)	24 V DC (20 ... 30 V DC) per group of 4 one V_B
U_B conditionally protected against polarity reversal ¹⁾	Up to 30 V DC
Current consumption	approx. 10 mA for 24 V DC + output currents per group of 4
Aggregate current	max. 8 A per group of 4
Switching outputs	
Number	8 channels (channel 0 ... 7)
Short-circuit protection ²⁾	for $U_B < 24$ V DC or 24 ... 30 V DC/max. 20 A
Output voltage	typ. $U_B - 1$ V (for input "on")
Output current	Max. 4 A per channel
• Lamp load	max. 20 W at 24 V per channel
Demand factor per group of 4	50 %, max. 2 outputs active under full load (4 A)
Short-circuit response	Clocked output signal (approx. 2 ... 20 ms)
On/off-delay	typ. 100 μ s/250 μ s with resistive load
Switching frequency	max. 500 Hz with 4 A resistive load (square wave voltage, pulse/pause 1:1)
"Overload" fault indication	Red LED per channel, in the event of wire breakage or short-circuit
• Wire break indication	Active $I_{out} < 0.1$ A/ inactive $I_{out} \geq 0.9$ A
Group fault messages SF1, SF2	
Monitored channels	SF1: Channels 0 ... 3, SF2: for channels 4 ... 7
Voltage U_{SF1} , U_{SF2}	
• No error at the switching output	typ. $U_B - 2$ V
• Wire break at the switching output	Approx. 0 V
• Short-circuit at the switching output	0 V to U_B , clocked
Current I_{SF1} , I_{SF2}	min. 4 mA/max. 200 mA
General data	
Degree of protection	IP20
Operating temperature	0 ... 60 °C
Mounting position	Any, except overhead
Connecting terminals	Screw-type or spring-loaded terminals
Stripped length	9 mm
Conductor cross-section	
• Finely stranded without end sleeve	0.5 ... 2.5 mm ²
• with end sleeve for screw-type terminals	0.5 ... 2.5 mm ² according to DIN 46228-1
• with end sleeve for spring-loaded terminals	0.5 ... 1.5 mm ² according to DIN 46228-1 and DIN 46228-4
Screwdriver	according to DIN 5264 B 0.6 x 3.5 mm
Tightening torque of screw-type terminals	0.4 Nm
Weight	Approx. 400 g
Dimensions (W x H x D) in mm	134 x 84 x 77

¹⁾ Protected against polarity reversal, if the ground potential of the output load is directly connected to the 0 V supply of the power supply unit

²⁾ Not sustained short-circuit-proof, max. duration approx. 60 min.

SIMATIC S7-300

Connection methods

SIMATIC TOP connect for SIMATIC S7
Fully modular connection

Technical specifications Function module (continued)

Connection module with relay for inputs (TPRi)	
Energizing side	
Operating voltage for coil	230 V AC from 207 – 280 V AC
Input circuit	Varistors
Contact side	
Number of relay outputs	8 (NO contacts)
Contact design	Single contact, 1 NO contact
Switching capacity (resistive load)	max. 50 A/24 V AC, max. 50 mA/48 V DC max. 50 mA/60 V DC recommended minimum load ≥ 5 mA
Switching frequency	200 cycles/minute
Service life	
• Mechanical	10 x 10 ⁶ switching cycles
• Electrical	3 x 10 ⁶ operating cycles at 230 V AC/50 mA/cos γ = 1
Operating temperature	0 ... +60 °C
Mounting position	Any
Clearance and creepage distances	Basic standard IEC 60664-1; UL 508; Cul (Reference CSA C22.2 No. 142) Overvoltage category III Pollution degree 2
Dimensions (W x H x D) in mm	
6ES7924-0BE10-0B_0	Approx. 130 x 45 x 80

Wiring rules for the connection modules

Connection modules TPRo and TPRi		
	Spring-loaded connection	Screw-type connection
Connectable cable cross-sections		
• Solid conductors	No	
• Flexible cables without end sleeve	0.5 ... 2.5 mm ²	
• Flexible cables with end sleeve according to DIN 46228/1	0.5 ... 1.5 mm ²	0.5 to 2.5 mm ² (2.5 mm ² with a crimp in accordance with EN 60947-1)
• Flexible cables with end sleeve and plastic collar according to DIN 46228/4	0.5 ... 1.5 mm ²	
Number of conductors per connection	1 or a combination of 2 conductors up to the cross-sections specified above (total) in a shared end sleeve	
Blade width of the screwdriver	3.5 mm (cylindrical design)	
Tightening torque for connecting the cables	-	0.4 ... 0.7 Nm

Ordering data

Order No.

Front connector module	
Front connector module (compact CPU 312C)	
Power supply via	
• Screw terminals	6ES7921-3AK20-0AA0
Front connector module (compact CPU 313C/314C-2PtP/314C-2DP), slot X1	
Power supply via	
• Screw terminals	6ES7921-3AM20-0AA0
Front connector module (digital 2 x 8 I/O)	
Power supply via	
• Spring-loaded terminals	6ES7921-3AA00-0AA0
• Screw terminals	6ES7921-3AB00-0AA0
Front connector module (digital 4 x 8 I/O)	
Power supply via	
• Spring-loaded terminals	6ES7921-3AA20-0AA0
• Screw terminals	6ES7921-3AB20-0AA0
Front connector module (1 x 8 outputs) for 2 ampere digital outputs	
Power supply via	
• Spring-loaded terminals	6ES7921-3AC00-0AA0
• Screw terminals	6ES7921-3AD00-0AA0
Front connector module 20-pin (analog)	
Power supply via	
• Spring-loaded terminals	6ES7921-3AF00-0AA0
• Screw terminals	6ES7921-3AG00-0AA0
Front connector module 40-pin (analog)	
Power supply via	
• Spring-loaded terminals	6ES7921-3AF20-0AA0
• Screw terminals	6ES7921-3AG20-0AA0

5

SIMATIC S7-300

Connection methods

SIMATIC TOP connect for SIMATIC S7
Fully modular connection

Ordering data

Order No.

Connecting cable

Pre-assembled round cable

16-pole, 0.14 mm²

Unshielded

• 0.5 m	6ES7923-0BA50-0CB0
• 1.0 m	6ES7923-0BB00-0CB0
• 1.5 m	6ES7923-0BB50-0CB0
• 2.0 m	6ES7923-0BC00-0CB0
• 2.5 m	6ES7923-0BC50-0CB0
• 3.0 m	6ES7923-0BD00-0CB0
• 4.0 m	6ES7923-0BE00-0CB0
• 5.0 m	6ES7923-0BF00-0CB0
• 6.5 m	6ES7923-0BG50-0CB0
• 8.0 m	6ES7923-0BJ00-0CB0
• 10.0 m	6ES7923-0CB00-0CB0

Shielded

• 1.0 m	6ES7923-0BB00-0DB0
• 2.0 m	6ES7923-0BC00-0DB0
• 2.5 m	6ES7923-0BC50-0DB0
• 3.0 m	6ES7923-0BD00-0DB0
• 4.0 m	6ES7923-0BE00-0DB0
• 5.0 m	6ES7923-0BF00-0DB0
• 6.5 m	6ES7923-0BG50-0DB0
• 8.0 m	6ES7923-0BJ00-0DB0
• 10.0 m	6ES7923-0CB00-0DB0

Round-sheath ribbon cable

16-pole, 0.14 mm²

Unshielded

• 30 m	6ES7923-0CD00-0AA0
• 60 m	6ES7923-0CG00-0AA0

Shielded

• 30 m	6ES7923-0CD00-0BA0
• 60 m	6ES7923-0CG00-0BA0

Round-sheath ribbon cable

2 x 16-pole, 0.14 mm²

Unshielded

• 30 m	6ES7923-2CD00-0AA0
• 60 m	6ES7923-2CG00-0AA0

Connector
(female ribbon connector)16-pole,
insulation displacement system,
with strain relief devices;
packing unit: 8 connectors and
8 cable grips

6ES7921-3BE10-0AA0

Accessories

Manual pliers

For preparing the connectors
(female ribbon connector)

6ES7928-0AA00-0AA0

Order No.

Basic module

Connection module TP1

for 1-wire initiators

Packaging unit (1 unit)
• Spring terminals
• Screw terminals6ES7924-0AA10-0AB0
6ES7924-0AA10-0AA0

Connection module TP3

for 3-wire initiators

Packaging unit (1 unit)
• Spring terminals
• Screw terminals6ES7924-0CA10-0AB0
6ES7924-0CA10-0AA0

Connection module TPK

for 2 x 8 signals

Packaging unit (1 unit)
• Spring terminals
• Screw terminals6ES7924-1AA10-0AB0
6ES7924-1AA10-0AA0

Connection module TP2

for 2 A modules

for 2-wire initiators

Packaging unit (1 unit)
• Spring terminals
• Screw terminals6ES7924-0BB10-0AB0
6ES7924-0BB10-0AA0

Connection module TPA

for analog signals

Packaging unit (1 unit)
• Spring terminals
• Screw terminals6ES7924-0CC10-0AB0
6ES7924-0CC10-0AA0

Accessories

Labeling plates

for connection modules

Insertable labeling plate
PU = 200 units

6ES7928-2AB00-0AA0

Self-adhesive labeling plate
PU = 200 units

6ES7928-2BB00-0AA0

Shield plate

for analog connection module
(4 units)

6ES7928-1BA00-0AA0

Shield connection terminal

for shield plate, 2 units,
with cable diameter

- 2 to 6 mm (2 cables)
- 3 to 8 mm
- 4 to 13 mm

6ES7390-5AB00-0AA0
6ES7390-5BA00-0AA0
6ES7390-5CA00-0AA0

SIMATIC S7-300

Connection methods

SIMATIC TOP connect for SIMATIC S7 Fully modular connection

Ordering data	Order No.	Order No.
Signal module		Function module
Connection module TP1 with LED for 1-wire initiators Packaging unit (1 unit) • Spring terminals • Screw terminals	6ES7924-0AA10-0BB0 6ES7924-0AA10-0BA0	Connection module TPRo for output signals for 2-wire connection Packaging unit 1 unit • Spring-loaded terminals • Screw-type terminals
Connection module TP3 with LED for 3-wire initiators Packaging unit (1 unit) • Spring terminals • Screw terminals	6ES7924-0CA10-0BB0 6ES7924-0CA10-0BA0	Connection module optocoupler Packaging unit 1 unit • Spring-loaded terminals • Screw-type terminals
Connection module TPK with LED for 2 x 8 signals Packaging unit (1 unit) • Spring terminals • Screw terminals	6ES7924-1AA10-0BB0 6ES7924-1AA10-0BA0	Connection module TPRi for input signals for 2-wire connection Packaging unit 1 unit • Spring-loaded terminals • Screw-type terminals
Connection module TP2 with LED for 2 A modules for 2-wire initiators Packaging unit (1 unit) • Spring terminals • Screw terminals	6ES7924-0BB10-0BB0 6ES7924-0BB10-0BA0	Accessories
Accessories		Labels for connection modules
Labeling plates for connection modules		Insertable labels PU = 200 units
Insertable labeling plate PU = 200 units	6ES7928-2AB00-0AA0	Self-adhesive labels PU = 200 units
Self-adhesive labeling plate PU = 200 units	6ES7928-2BB00-0AA0	Replacement relay for relay connection module PU = 4 units
		Replacement relay for TPRi
		Replacement relay for TPRo
		Optocoupler DC alternative for relay in the case of TPRo PU = 4 units
		Optocoupler AC alternative for relay in the case of TPRo PU = 4 units

SIMATIC S7-300

Connection methods

SIMATIC TOP connect for SIMATIC S7 Flexible connection

Overview



The flexible connection guarantees a fast and direct connection from the input/output modules of the SIMATIC S7-300/400 to the individual elements in the cabinet.

Already attached single cores reduce the wiring effort.

The core cross-sections of 0,5 mm² also allow higher currents.

Technical specifications

Front connector with single cores for 16 channels

Rated operating voltage	24 V DC
Permissible continuous current with simultaneous load of all wires, max.	1.5 A
Permissible ambient temperature	0 to 60 °C
Core type	H05V-K or with UL 1007/1569; CSA TR64
Number of single cores	20
Core cross-section	0.5 mm ² ; Cu
Bundle diameter in mm	approx. 15
Core color	Blue, RAL 5010
Designation of cores	Numbered from 1 to 20 (front connector contact = core number)
Assembly	Screw-type or crimp contacts

Front connector with single cores for 32 channels

Rated operating voltage	24 V DC
Permissible continuous current with simultaneous load of all wires, max.	1.5 A
Permissible ambient temperature	0 to 60 °C
Core type	H05V-K or with UL 1007/1569; CSA TR64
Number of single cores	40
Core cross-section	0.5 mm ² ; Cu
Bundle diameter in mm	approx. 17
Core color	Blue, RAL 5010
Designation of cores	Numbered from 1 to 40 (front connector contact = core number)
Assembly	Screw-type or crimp contacts

Ordering data

Order No.

Front connector with single cores for 16-channel digital modules SIMATIC S7-300, 20 x 0.5 mm²

Core type H05V-K

Screw-type version

Packaging unit: 1 unit

Length:

- 2.5 m
- 3.2 m
- 5 m
- Custom lengths

Packaging unit: 5 units

Length:

- 2.5 m
- 3.2 m
- 5.0 m

Crimp version

Packaging unit: 1 unit

Length:

- 2.5 m
- 3.2 m
- 5.0 m
- Custom lengths

6ES7922-3BC50-0AB0
6ES7922-3BD20-0AB0
6ES7922-3BF00-0AB0
On request

6ES7922-3BC50-5AB0
6ES7922-3BD20-5AB0
6ES7922-3BF00-5AB0

6ES7922-3BC50-0AF0
6ES7922-3BD20-0AF0
6ES7922-3BF00-0AF0
On request

Core type UL/CSA-certified

Screw-type version

Packaging unit: 1 unit

Length:

- 3.2 m
- 5.0 m

6ES7922-3BD20-0UB0
6ES7922-3BF00-0UB0

Front connector with single cores for 32-channel digital modules SIMATIC S7-300, 40 x 0.5 mm²

Core type H05V-K

Screw-type version

Packaging unit: 1 unit

Length:

- 2.5 m
- 3.2 m
- 5.0 m
- Custom lengths

6ES7922-3BC50-0AC0
6ES7922-3BD20-0AC0
6ES7922-3BF00-0AC0
On request

Packaging unit: 5 units

Length:

- 2.5 m
- 3.2 m
- 5.0 m

6ES7922-3BC50-5AC0
6ES7922-3BD20-5AC0
6ES7922-3BF00-5AC0

Crimp version

Packaging unit: 1 unit

Length:

- 2.5 m
- 3.2 m
- 5.0 m
- Custom lengths

6ES7922-3BC50-0AG0
6ES7922-3BD20-0AG0
6ES7922-3BF00-0AG0
On request

Core type UL/CSA-certified

Screw version

Packaging unit: 1 unit

Length:

- 3.2 m
- 5.0 m

6ES7922-3BD20-0UC0
6ES7922-3BF00-0UC0

Overview



- For connecting mounting racks in multi-tier SIMATIC S7-300 configurations
- IM 365:
For design of central controller and max. 1 expansion unit.
Limited use of modules in the expansion unit (e.g. no CPs or FMs)
- IM 360/IM 361:
For design of central controller and max. 3 expansion units.
No limitation in selection of modules in the expansion unit

Technical specifications

	6ES7 360-3AA01-0AA0	6ES7 361-3CA01-0AA0	6ES7 365-0BA01-0AA0
Supply voltage 24 V DC		Yes	
Input current from backplane bus 5 V DC, max.	350 mA		100 mA
from supply voltage L+, max.		500 mA	
Power losses Power loss, typ.	2 W	5 W	0.5 W
Hardware configuration Number of interfaces per CPU, max.	1	3	1; 1 pair
Dimensions Width	40 mm	80 mm	40 mm
Height	125 mm	125 mm	125 mm
Depth	120 mm	120 mm	120 mm
Weight Weight, approx.	225 g	505 g	580 g

Ordering data

Ordering data	Order No.	Ordering data	Order No.
IM 360 interface module for expanding the S7-300 with max. 3 EUs; can be plugged into CC	6ES7 360-3AA01-0AA0	SIMATIC Manual Collection Electronic manuals on DVD, multilingual: LOGO!, SIMADYN, SIMATIC bus components, SIMATIC C7, SIMATIC distributed I/O, SIMATIC HMI, SIMATIC Sensors, SIMATIC NET, SIMATIC PC Based Automation, SIMATIC PCS 7, SIMATIC PG/PC, SIMATIC S7, SIMATIC Software, SIMATIC TDC	6ES7 998-8XC01-8YE0
IM 361 interface module for expanding the S7-300 with max. 3 EUs; can be plugged into EU	6ES7 361-3CA01-0AA0	SIMATIC Manual Collection update service for 1 year Current "Manual Collection" DVD and the three subsequent updates	6ES7 998-8XC01-8YE2
Connecting cable between IM 360 and IM 361 or IM 361 and IM 361		S7-300 manual Design, CPU data, module data, instruction list	
1 m	6ES7 368-3BB01-0AA0	German	6ES7 398-8FA10-8AA0
2.5 m	6ES7 368-3BC51-0AA0	English	6ES7 398-8FA10-8BA0
5 m	6ES7 368-3BF01-0AA0		
10 m	6ES7 368-3CB01-0AA0		
IM 365 interface module for expanding the S7-300 with max. 1 EU; 2 modules with permanent connecting cable (1 m)	6ES7 365-0BA01-0AA0		

SIMATIC S7-300

SIPLUS interface modules

SIPLUS IM 365 interface modules

Overview



- SIPLUS IM 365: For configuration of 1 central controller and max. 1 expansion unit

Note:

SIPLUS extreme products are based on Siemens Industry standard products. The contents listed here were taken from the respective standard products. SIPLUS extreme specific information was added.

SIPLUS IM 365 interface module	
Order No.	6AG1 365-0BA01-2AA0
Order number based on	6ES7 365-0BA01-0AA0
Ambient temperature range	-25 ... +60 °C
Conformal coating	Coating of the printed circuit boards and the electronic components
Technical data	The technical data of the standard product applies, except for the ambient conditions.
Ambient conditions	
Relative humidity	100%, condensation/frost permissible. No commissioning if condensation present.
Biologically active substances, compliance with EN 60721-3-3	Class 3B2 mold and fungal spores (excluding fauna). The supplied plug covers must remain in place over the unused interfaces during operation!
Chemically active substances, compliance with EN 60721-3-3	Class 3C4 incl. salt spray in accordance with EN 60068-2-52 (degree of severity 3). The supplied plug covers must remain in place over the unused interfaces during operation!
Mechanically active substances, compliance with EN 60721-3-3	Class 3S4 incl. sand, dust. The supplied plug covers must remain in place over the unused interfaces during operation!
Air pressure (depending on the highest positive temperature range specified)	1080 ... 795 hPa (-1 000 ... +2 000 m) see ambient temperature range 795 ... 658 hPa (+2 000 ... +3 500 m) derating 10 K 658 ... 540 hPa (+3 500 ... +5 000 m) derating 20 K

For technical documentation on SIPLUS, see:
www.siemens.com/siplus-extreme

Technical specifications

Interface module	
Interface module	SIPLUS IM 365
Order No.	6AG1 365-0BA01-2AA0
Order No. based on	6ES7 365-0BA01-0AA0
Ambient temperature range	-25 °C to +60 °C, condensation permissible
Ambient conditions	Suitable for extraordinary medial exposure (e.g. by chloric and sulphuric atmospheres).
Max. interface modules per CPU	1 pair
Supply voltage (external)	-
Current consumption	-
• from 24 V DC line	-
• from internal bus (5V)	100 mA
Power loss typ.	0.5 W
Dimensions (W x H x D) in mm	40 x 125 x 120 per module
Weight, approx.	580 g (total)

Ordering data

Ordering data	
SIPLUS IM 365 interface module (extended temperature range and medial exposure) for expansion of S7-300 with max. 1 EU; 2 modules with fixed connection cable (1 m)	6AG1 365-0BA01-2AA0

Application



The proven power supply in the SIMATIC S7-300 design; with PS-CPU connecting comb and for mounting on S7 rail.

Technical specifications 1-phase, 24 V DC/2 A

Order No.	6ES7 307-1BA01-0AA0	Order No.	6ES7 307-1BA01-0AA0
Product	PS 307	Product	PS 307
Power supply, type	24 V/2 A	Power supply, type	24 V/2 A
Input		Output	
Input	1-phase AC	Output	Controlled, isolated DC voltage
Supply voltage		Rated voltage V_{out} DC	24 V
• 1 at AC nominal value	120 V	Total tolerance, static \pm	3 %
• 2 at AC nominal value	230 V	Static mains compensation, approx.	0.1 %
• at DC		Static load balancing, approx.	0.2 %
• Note	Automatic range selection	Residual ripple peak-peak, max.	50 mV
Input voltage		Residual ripple peak-peak, typ.	5 mV
• 1 at AC	85 ... 132 V	Spikes peak-peak, max. (bandwidth: 20 MHz)	150 mV
• 2 at AC	170 ... 264 V	Spikes peak-peak, typ. (bandwidth: 20 MHz)	20 mV
• at DC		Product feature output voltage adjustable	No
Overvoltage resistance	$2.3 \times V_{in \text{ rated}}$, 1.3 ms	Output voltage setting	-
Mains buffering at $I_{out \text{ rated}}$, min.	0.02 s	Status display	Green LED for 24 V OK
Mains buffering	at $V_{in} = 93/187$ V	On/off behavior	No overshoot of V_{out} (soft start)
Rated line frequency		Startup delay, max.	2 s
• 1	50 Hz	Voltage rise, typ.	10 ms
• 2	60 Hz	Rated current value $I_{out \text{ rated}}$	2 A
Rated line range	47 ... 63 Hz	Current range	0 ... 2 A
Input current		Note	
• at nominal level of the input voltage 120 V nominal value	0.9 A	delivered active power typ.	48 W
• at nominal level of the input voltage 230 V nominal value	0.5 A	short-term overload current at short-circuit during run-up typical	9 A
• at nominal level of the input voltage 24 V nominal value		Duration of overloading ability for excess current on short-circuiting during the start-up	90 ms
• at nominal level of the input voltage 110 V nominal value		short-term overload current at short-circuit during operation typical	9 A
Switch-on current limiting (+25 °C), max.	22 A	Duration of overloading ability for excess current on short-circuiting during the operational phase	90 ms
Duration of current limiting at 25 °C maximum	3 ms	Parallel switching for enhanced performance	Yes
I^2t , max.	1 A ² ·s	Numbers of parallel switchable units for enhanced performance	
Built-in incoming fuse	T 1.6 A/250 V (not accessible)		
Protection in the mains power input (IEC 898)	Recommended miniature circuit breaker: 3 A, characteristic C		

SIMATIC S7-300

Power supplies

The S7-300 version

Technical specifications 1-phase, 24 V DC/2 A (continued)

Order No.	6ES7 307-1BA01-0AA0
Product	PS 307
Power supply, type	24 V/2 A
Efficiency	
Efficiency at $V_{out\ rated}$, $I_{out\ rated}$, approx.	84 %
Power loss at $V_{out\ rated}$, $I_{out\ rated}$, approx.	9 W
Closed-loop control	
Dynamic mains compensation ($V_{in\ rated} \pm 15\%$), max.	0.1 %
Dynamic load smoothing (I_{out} : 50/100/50 %), $U_{out} \pm$ typ.	0.8 %
Load step setting time 50 to 100%, typ.	0.5 ms
Load step setting time 100 to 50%, typ.	0.5 ms
Setting time maximum	1 ms
Protection and monitoring	
Output overvoltage protection	Additional control loop, shutdown at < 28.8 V, automatic restart
Current limitation	2.2 ... 2.6 A
Characteristic feature of the output short-circuit protected	Yes
Short-circuit protection	Electronic shutdown, automatic restart
Enduring short circuit current Effective level maximum	2 A
Overload/short-circuit indicator	-
Safety	
Primary/secondary isolation	Yes
Potential separation	Safety extra-low output voltage U_{out} acc. to EN 60950-1 and EN 50178
Protection class	Class I
stray current	
• maximum	3.5 mA
• typical	0.5 mA
CE mark	Yes
UL/CSA approval	Yes
UL/cUL (CSA) approval	cULus-Listed (UL 508, CSA C22.2 No. 142), File E143289, UL 1604 Class I Div. 2 Group A, B, C, D, File E330455
Explosion protection	ATEX (EX) II 3G Ex nA II T4; UL 1604 Class I, Div. 2, Group ABCD
FM approval	Yes Class I, Div. 2, Group ABCD, T4
CB approval	No
Marine approval	In S7-300 system
Degree of protection (EN 60529)	IP20

Order No.	6ES7 307-1BA01-0AA0
Product	PS 307
Power supply, type	24 V/2 A
EMC	
Emitted interference	EN 55022 Class B
Supply harmonics limitation	not applicable
Noise immunity	EN 61000-6-2
Operating data	
Ambient temperature	
• in operation	0 ... 60 °C
- Note	with natural convection
Ambient temperature	
• on transport	-40 ... +85 °C
Ambient temperature	
• in storage	-40 ... +85 °C
Humidity class according to EN 60721	Climate class 3K3, no condensation
Mechanics	
Connection technology	screw-type terminals
Connections	
• Supply input	L, N, PE: 1 screw terminal each for 0.5 ... 2.5 mm ² single-core/finely stranded
• Output	L+, M: 2 screw terminals each for 0.5 ... 2.5 mm ²
• Auxiliary	-
Width of the housing	40 mm
Height of the housing	125 mm
Depth of the housing	120 mm
Installation width	40 mm
Installation height	205 mm
Weight, approx.	0.4 kg
Product feature of the housing housing for side-by-side mounting	Yes
Type of mounting wall mounting	No
Type of fixing cap rail mounting	No
Type of mounting S7-300 rail mounting	Yes
Installation	Can be mounted onto S7 rail
Mechanical accessories	Mounting adapter for standard mounting rail (6EP1971-1BA00)

Technical specifications 1-phase, 24 V DC/5 A

Order No.	6ES7 307-1EA01-0AA0
Product	PS 307
Power supply, type	24 V/5 A
Input	
Input	1-phase AC
Supply voltage	
• 1 at AC nominal value	120 V
• 2 at AC nominal value	230 V
• at DC	
• Note	Automatic range selection
Input voltage	
• 1 at AC	85 ... 132 V
• 2 at AC	170 ... 264 V
• at DC	
Overvoltage resistance	$2.3 \times V_{in \text{ rated}}$, 1.3 ms
Mains buffering at $I_{out \text{ rated}}$, min.	20 ms
Mains buffering	at $V_{in} = 93/187 \text{ V}$
Rated line frequency	
• 1	50 Hz
• 2	60 Hz
Rated line range	47 ... 63 Hz
Input current	
• at nominal level of the input voltage 120 V nominal value	2.3 A
• at nominal level of the input voltage 230 V nominal value	1.2 A
• at nominal level of the input voltage 24 V nominal value	
• at nominal level of the input voltage 110 V nominal value	
Switch-on current limiting (+25 °C), max.	20 A
Duration of current limiting at 25 °C maximum	3 ms
I^2t , max.	1.2 A ² ·s
Built-in incoming fuse	T 3,15 A/250 V (not accessible)
Protection in the mains power input (IEC 898)	Recommended miniature circuit breaker: from 6 A, characteristic C
Output	
Output	Controlled, isolated DC voltage
Rated voltage $V_{out \text{ DC}}$	24 V
Total tolerance, static \pm	3 %
Static mains compensation, approx.	0.1 %
Static load balancing, approx.	0.5 %
Residual ripple peak-peak, max.	50 mV
Residual ripple peak-peak, typ.	10 mV
Spikes peak-peak, max. (bandwidth: 20 MHz)	150 mV
Spikes peak-peak, typ. (bandwidth: 20 MHz)	20 mV
Product feature output voltage adjustable	No
Output voltage setting	-

Order No.	6ES7 307-1EA01-0AA0
Product	PS 307
Power supply, type	24 V/5 A
Status display	Green LED for 24 V OK
On/off behavior	No overshoot of V_{out} (soft start)
Startup delay, max.	2 s
Voltage rise, typ.	10 ms
Rated current value $I_{out \text{ rated}}$	5 A
Current range	0 ... 5 A
Note	
delivered active power typ.	120 W
short-term overload current at short-circuit during run-up typical	20 A
Duration of overloading ability for excess current on short-circuiting during the start-up	100 ms
short-term overload current at short-circuit during operation typical	20 A
Duration of overloading ability for excess current on short-circuiting during the operational phase	100 ms
Parallel switching for enhanced performance	Yes
Numbers of parallel switchable units for enhanced performance	
Efficiency	
Efficiency at $V_{out \text{ rated}}$, $I_{out \text{ rated}}$, approx.	87 %
Power loss at $V_{out \text{ rated}}$, $I_{out \text{ rated}}$, approx.	18 W
Closed-loop control	
Dynamic mains compensation ($V_{in \text{ rated}} \pm 15 \%$), max.	0.1 %
Dynamic load smoothing (I_{out} : 50/100/50 %), $U_{out} \pm$ typ.	1 %
Load step setting time 50 to 100%, typ.	0.3 ms
Load step setting time 100 to 50%, typ.	0.3 ms
Setting time maximum	
Protection and monitoring	
Output overvoltage protection	Additional control loop, shutdown at < 28.8 V, automatic restart
Current limitation	5.5 ... 6.5 A
Characteristic feature of the output short-circuit protected	Yes
Short-circuit protection	Electronic shutdown, automatic restart
Enduring short circuit current Effective level maximum	7 A
Overload/short-circuit indicator	

SIMATIC S7-300

Power supplies

The S7-300 version

Technical specifications 1-phase, 24 V DC/5 A (continued)

Order No.	6ES7 307-1EA01-0AA0
Product	PS 307
Power supply, type	24 V/5 A
Safety	
Primary/secondary isolation	Yes
Potential separation	Safety extra-low output voltage U_{out} acc. to EN 60950-1 and EN 50178
Protection class	Class I
stray current	
• maximum	3.5 mA
• typical	0.5 mA
CE mark	Yes
UL/CSA approval	Yes
UL/cUL (CSA) approval	cULus-Listed (UL 508, CSA C22.2 No. 142), File E143289, UL 1604 Class I Div. 2 Group A, B, C, D, File E330455
Explosion protection	ATEX (EX) II 3G Ex nA II T4; UL 1604 Class I, Div. 2, Group ABCD
FM approval	Yes
FM approval	Class I, Div. 2, Group ABCD, T4
CB approval	No
Marine approval	In S7-300 system
Degree of protection (EN 60529)	IP20
EMC	
Emitted interference	EN 55022 Class B
Supply harmonics limitation	EN 61000-3-2
Noise immunity	EN 61000-6-2
Operating data	
Ambient temperature	
• in operation	0 ... 60 °C
- Note	with natural convection
Ambient temperature	
• on transport	-40 ... +85 °C
Ambient temperature	
• in storage	-40 ... +85 °C
Humidity class according to EN 60721	Climate class 3K3, no condensation

Order No.	6ES7 307-1EA01-0AA0
Product	PS 307
Power supply, type	24 V/5 A
Mechanics	
Connection technology	screw-type terminals
Connections	
• Supply input	L, N, PE: 1 screw terminal each for 0.5 ... 2.5 mm ² single-core/finely stranded
• Output	L+, M: 3 screw terminals each for 0.5 ... 2.5 mm ²
• Auxiliary	-
Width of the housing	60 mm
Height of the housing	125 mm
Depth of the housing	120 mm
Installation width	60 mm
Installation height	205 mm
Weight, approx.	0.6 kg
Product feature of the housing housing for side-by-side mounting	Yes
Type of mounting wall mounting	No
Type of fixing cap rail mounting	No
Type of mounting S7-300 rail mounting	Yes
Installation	Can be mounted onto S7 rail
Mechanical accessories	Mounting adapter for standard mounting rail (6EP1971-1BA00)

Technical specifications 1-phase, 24 V DC/10 A

Order No.	6ES7 307-1KA02-0AA0
Product	PS 307
Power supply, type	24 V/10 A
Input	
Input	1-phase AC
Supply voltage	
• 1 at AC nominal value	120 V
• 2 at AC nominal value	230 V
• at DC	
• Note	Automatic range selection
Input voltage	
• 1 at AC	85 ... 132 V
• 2 at AC	170 ... 264 V
• at DC	
Overvoltage resistance	$2.3 \times V_{in \text{ rated}}$, 1.3 ms
Mains buffering at $I_{out \text{ rated}}$, min.	20 ms
Mains buffering	at $V_{in} = 93/187 \text{ V}$
Rated line frequency	
• 1	50 Hz
• 2	60 Hz
Rated line range	47 ... 63 Hz
Input current	
• at nominal level of the input voltage 120 V nominal value	4.2 A
• at nominal level of the input voltage 230 V nominal value	1.9 A
• at nominal level of the input voltage 24 V nominal value	
• at nominal level of the input voltage 110 V nominal value	
Switch-on current limiting (+25 °C), max.	55 A
Duration of current limiting at 25 °C maximum	3 ms
I^2t , max.	3.3 A ² ·s
Built-in incoming fuse	T 6.3 A/250 V (not accessible)
Protection in the mains power input (IEC 898)	Recommended miniature circuit breaker: from 10 A, characteristic C
Output	
Output	Controlled, isolated DC voltage
Rated voltage $V_{out \text{ DC}}$	24 V
Total tolerance, static \pm	3 %
Static mains compensation, approx.	0.1 %
Static load balancing, approx.	0.5 %
Residual ripple peak-peak, max.	50 mV
Residual ripple peak-peak, typ.	15 mV
Spikes peak-peak, max. (bandwidth: 20 MHz)	150 mV
Spikes peak-peak, typ. (bandwidth: 20 MHz)	60 mV
Product feature output voltage adjustable	No
Output voltage setting	-

Order No.	6ES7 307-1KA02-0AA0
Product	PS 307
Power supply, type	24 V/10 A
Status display	Green LED for 24 V OK
On/off behavior	No overshoot of V_{out} (soft start)
Startup delay, max.	2 s
Voltage rise, typ.	10 ms
Rated current value $I_{out \text{ rated}}$	10 A
Current range	0 ... 10 A
Note	
delivered active power typ.	240 W
short-term overload current at short-circuit during run-up typical	38 A
Duration of overloading ability for excess current on short-circuiting during the start-up	80 ms
short-term overload current at short-circuit during operation typical	38 A
Duration of overloading ability for excess current on short-circuiting during the operational phase	80 ms
Parallel switching for enhanced performance	Yes
Numbers of parallel switchable units for enhanced performance	
Efficiency	
Efficiency at $V_{out \text{ rated}}$, $I_{out \text{ rated}}$, approx.	90 %
Power loss at $V_{out \text{ rated}}$, $I_{out \text{ rated}}$, approx.	27 W
Closed-loop control	
Dynamic mains compensation ($V_{in \text{ rated}} \pm 15 \%$), max.	0.1 %
Dynamic load smoothing (I_{out} : 50/100/50 %), $U_{out} \pm$ typ.	2 %
Load step setting time 50 to 100%, typ.	
Load step setting time 100 to 50%, typ.	
Setting time maximum	0.1 ms
Protection and monitoring	
Output overvoltage protection	Additional control loop, shutdown at < 28.8 V, automatic restart
Current limitation	11 ... 12 A
Characteristic feature of the output short-circuit protected	Yes
Short-circuit protection	Electronic shutdown, automatic restart
Enduring short circuit current Effective level maximum	12 A
Overload/short-circuit indicator	-

SIMATIC S7-300

Power supplies

The S7-300 version

Technical specifications 1-phase, 24 V DC/10 A (continued)

Order No.	6ES7 307-1KA02-0AA0
Product	PS 307
Power supply, type	24 V/10 A
Safety	
Primary/secondary isolation	Yes
Potential separation	Safety extra-low output voltage U_{out} acc. to EN 60950-1 and EN 50178
Protection class	Class I
stray current	
• maximum	3.5 mA
• typical	0.6 mA
CE mark	Yes
UL/CSA approval	Yes
UL/cUL (CSA) approval	cULus-Listed (UL 508, CSA C22.2 No. 142), File E143289, UL 1604 Class I Div. 2 Group A, B, C, D, File E330455
Explosion protection	ATEX (EX) II 3G Ex nA II T4; UL 1604 Class I, Div. 2, Group ABCD
FM approval	Yes
FM approval	Class I, Div. 2, Group ABCD, T4
CB approval	No
Marine approval	In S7-300 system
Degree of protection (EN 60529)	IP20
EMC	
Emitted interference	EN 55022 Class B
Supply harmonics limitation	EN 61000-3-2
Noise immunity	EN 61000-6-2

Order No.	6ES7 307-1KA02-0AA0
Product	PS 307
Power supply, type	24 V/10 A
Operating data	
Ambient temperature	
• in operation	0 ... 60 °C
- Note	with natural convection
Ambient temperature	
• on transport	-40 ... +85 °C
Ambient temperature	
• in storage	-40 ... +85 °C
Humidity class according to EN 60721	Climate class 3K3, no condensation
Mechanics	
Connection technology	screw-type terminals
Connections	
• Supply input	L, N, PE: 1 screw terminal each for 0.5 ... 2.5 mm ² single-core/finely stranded
• Output	L+, M: 4 screw terminals each for 0.5 ... 2.5 mm ²
• Auxiliary	-
Width of the housing	80 mm
Height of the housing	125 mm
Depth of the housing	120 mm
Installation width	80 mm
Installation height	205 mm
Weight, approx.	0.8 kg
Product feature of the housing housing for side-by-side mounting	Yes
Type of mounting wall mounting	No
Type of fixing cap rail mounting	No
Type of mounting S7-300 rail mounting	Yes
Installation	Can be mounted onto S7 rail
Mechanical accessories	Mounting adapter for standard mounting rail (6EP1971-1BA00)

Technical specifications 1-phase, 24 V DC/5 A (outdoor)

Order No.	6ES7 307-1EA80-0AA0
Product	PS 307
Power supply, type	24 V/5 A
Input	
Input	1-phase AC
Supply voltage	
• 1 at AC nominal value	120 V
• 2 at AC nominal value	230 V
• at DC	
• Note	Set by means of selector switch on the device
Input voltage	
• 1 at AC	93 ... 132 V
• 2 at AC	187 ... 264 V
• at DC	
Overvoltage resistance	$2.3 \times V_{in \text{ rated}}$, 1.3 ms
Mains buffering at $I_{out \text{ rated}}$, min.	20 ms
Mains buffering	at $V_{in} = 93/187 \text{ V}$
Rated line frequency	
• 1	50 Hz
• 2	60 Hz
Rated line range	47 ... 63 Hz
Input current	
• at nominal level of the input voltage 120 V nominal value	2.1 A
• at nominal level of the input voltage 230 V nominal value	1.2 A
• at nominal level of the input voltage 24 V nominal value	
• at nominal level of the input voltage 110 V nominal value	
Switch-on current limiting (+25 °C), max.	45 A
Duration of current limiting at 25 °C maximum	3 ms
I^2t , max.	1.8 A ² ·s
Built-in incoming fuse	T 3, 15 A/250 V (not accessible)
Protection in the mains power input (IEC 898)	Recommended miniature circuit breaker: from 10 A, characteristic C, or from 6 A, characteristic D
Output	
Output	Controlled, isolated DC voltage
Rated voltage $V_{out \text{ DC}}$	24 V
Total tolerance, static ±	3 %
Static mains compensation, approx.	0.2 %
Static load balancing, approx.	0.4 %
Residual ripple peak-peak, max.	150 mV
Residual ripple peak-peak, typ.	40 mV
Spikes peak-peak, max. (bandwidth: 20 MHz)	240 mV
Spikes peak-peak, typ. (bandwidth: 20 MHz)	90 mV

Order No.	6ES7 307-1EA80-0AA0
Product	PS 307
Power supply, type	24 V/5 A
Product feature output voltage adjustable	No
Output voltage setting	-
Status display	Green LED for 24 V OK
On/off behavior	No overshoot of V_{out} (soft start)
Startup delay, max.	3 s
Voltage rise, typ.	100 ms
Rated current value $I_{out \text{ rated}}$	5 A
Current range	0 ... 5 A
Note	
delivered active power typ.	120 W
short-term overload current at short-circuit during run-up typical	20 A
Duration of overloading ability for excess current on short-circuiting during the start-up	180 ms
short-term overload current at short-circuit during operation typical	20 A
Duration of overloading ability for excess current on short-circuiting during the operational phase	80 ms
Parallel switching for enhanced performance	No
Numbers of parallel switchable units for enhanced performance	
Efficiency	
Efficiency at $V_{out \text{ rated}}$, $I_{out \text{ rated}}$, approx.	84 %
Power loss at $V_{out \text{ rated}}$, $I_{out \text{ rated}}$, approx.	23 W
Closed-loop control	
Dynamic mains compensation ($V_{in \text{ rated}} \pm 15 \%$), max.	0.3 %
Dynamic load smoothing (I_{out} : 50/100/50 %), $U_{out} \pm$ typ.	3 %
Load step setting time 50 to 100%, typ.	0.2 ms
Load step setting time 100 to 50%, typ.	0.2 ms
Setting time maximum	5 ms
Protection and monitoring	
Output overvoltage protection	Additional control loop, shutdown at approx. 30 V, automatic restart
Current limitation	5.5 ... 6.5 A
Characteristic feature of the output short-circuit protected	Yes
Short-circuit protection	Electronic shutdown, automatic restart
Enduring short circuit current Effective level maximum	5 A
Overload/short-circuit indicator	

SIMATIC S7-300

Power supplies

The S7-300 version

Technical specifications 1-phase, 24 V DC/5 A (outdoor) (continued)

Order No.	6ES7 307-1EA80-0AA0	Order No.	6ES7 307-1EA80-0AA0
Product	PS 307	Product	PS 307
Power supply, type	24 V/5 A	Power supply, type	24 V/5 A
Safety		Mechanics	
Primary/secondary isolation	Yes	Connection technology	screw-type terminals
Potential separation	Safety extra low output voltage V_{out} according to EN 60950-1 and EN 50178, creepage distances and clearances > 5 mm	Connections	
Protection class	Class I	• Supply input	L, N, PE: 1 screw terminal each for 0.5 ... 2.5 mm ² single-core/finely stranded
stray current		• Output	L+, M: 3 screw terminals each for 0.5 ... 2.5 mm ²
• maximum	3.5 mA	• Auxiliary	-
• typical	0.3 mA	Width of the housing	80 mm
CE mark	Yes	Height of the housing	125 mm
UL/CSA approval	Yes	Depth of the housing	120 mm
UL/cUL (CSA) approval	UL-Listed (UL 508), File E143289, CSA (CSA C22.2 No. 142)	Installation width	80 mm
Explosion protection	-	Installation height	205 mm
FM approval	No	Weight, approx.	0.57 kg
FM approval		Product feature of the housing housing for side-by-side mounting	Yes
CB approval	No	Type of mounting wall mounting	No
Marine approval	-	Type of fixing cap rail mounting	No
Degree of protection (EN 60529)	IP20	Type of mounting S7-300 rail mounting	Yes
EMC		Installation	Can be mounted onto S7 rail
Emitted interference	EN 55011 Class A	Mechanical accessories	Mounting adapter for standard mounting rail (6ES7390-6BA00-0AA0)
Supply harmonics limitation	-		
Noise immunity	EN 61000-6-2		
Operating data			
Ambient temperature			
• in operation	-25 ... +70 °C		
- Note	with natural convection		
Ambient temperature			
• on transport	-40 ... +85 °C		
Ambient temperature			
• in storage	-40 ... +85 °C		
Humidity class according to EN 60721	Climate class 3K5, transient condensation permitted		

SIMATIC S7-300

Power supplies

The S7-300 version

Ordering data	Order No.	Ordering data	Order No.
PS 307 load current supply, 2 A incl. connecting comb 120/230 V AC; 24 V DC Output current 2 A (dimensions 40 x 125 x 120)	6ES7 307-1BA01-0AA0	Accessories Mounting adapter For snapping the new PS 307 onto a 35 mm DIN rail (EN 50022) Spare part	6EP1 971-1BA00
PS 307 load current supply, 5 A incl. connecting comb 120/230 V AC; 24 V DC Output current 5 A (dimensions 60 x 125 x 120)	6ES7 307-1EA01-0AA0	SIMATIC S7-300 mounting adapter for snapping the PS307 onto 35 mm standard rails	6ES7390-6BA00-0AA0
PS 307 load current supply, 10 A incl. connecting comb 120/230 V AC; 24 V DC Output current 10 A (dimensions 80 x 125 x 120)	6ES7 307-1KA02-0AA0		
SIPLUS S7-300 PS 307, 10 A (extended temperature range -25 ... +70 °C and medial loading)	6AG1307-1KA02-7AA0		
SIPLUS S7-300 PS 307 -25 ... +70°C with Conformal Coating EN 50155 certified based on 6ES7307-1EA80-0AA0 stabilized power supply Input: 120/230 V AC Output: 24 V DC/5 A	6AG1307-1EA80-2AA0		

SIMATIC S7-300

SIPLUS power supplies

SIPLUS S7-300 PS 305

Overview



Note:

SIPLUS extreme products are based on Siemens Industry standard products. The contents listed here were taken from the respective standard products. SIPLUS extreme-specific information was added.

SIPLUS S7-300 PS 305	
Order number	6AG1 305-1BA80-2AA0
Order number based on	6ES7 305-1BA80-0AA0
Conformal coating	Coating of the printed circuit boards and the electronic components
Ambient temperature range	-25 ... +70 °C
Ambient conditions	Suitable for extraordinary medial exposure (e.g. chlorine sulfur atmosphere)
Technical data	The technical data of the standard product applies except for the ambient conditions.
Compliant with the standards for electronic equipment used on railway rolling stock (EN 50155, temperature T1, category 1).	Yes
Ambient conditions	
Relative humidity	100%, condensation/frost permissible. No commissioning if condensation present.
Biologically active substances, compliance with EN 60721-3-3	Class 3B2 mold spores, fungal spores (excluding fauna). The supplied plug covers must remain in place over the unused interfaces during operation!
Chemically active substances, compliance with EN 60721-3-3	Class 3C4 incl. salt spray in accordance with EN 60068-2-52 (degree of severity 3). The supplied plug covers must remain in place over the unused interfaces during operation!
Mechanically active substances, compliance with EN 60721-3-3	Class 3S4 incl. sand, dust. The supplied plug covers must remain in place over the unused interfaces during operation!
Air pressure (depending on the highest positive temperature range specified)	1080 ... 795 hPa (-1000 ... +2000 m) see ambient temperature range 795 ... 658 hPa (+2000 ... +3500 m) derating 10 K 658 ... 540 hPa (+3500 ... +5000 m) derating 20 K

For technical documentation on SIPLUS, see:
www.siemens.com/siplus-extreme

Ordering data	Order No.
SIPLUS S7-300 PS 305 load power supply (extended temperature range and medial exposure) Stabilized power supply PS305 Input: 24 ... 110 V DC Output: 24 V DC/2 A	6AG1 305-1BA80-2AA0
Accessories	

SIMATIC S7-300

SIPLUS power supplies

SIPLUS S7-300 PS 307, 5 A

Overview



Note:

SIPLUS extreme products are based on Siemens Industry standard products. The contents listed here were taken from the respective standard products. SIPLUS extreme-specific information was added.

SIPLUS S7-300 PS 307, 5 A

Order number	6AG1 307-1EA01-7AA0
Order number based on	6ES7 307-1EA01-0AA0
Conformal coating	Coating of the printed circuit boards and the electronic components
Ambient temperature range	-25 ... +70 °C
Technical data	The technical data of the standard product applies except for the ambient conditions.
Compliant with the standards for electronic equipment used on railway rolling stock (EN 50155, temperature T1, category 1).	Yes
Ambient conditions	
Relative humidity	100%, condensation/frost permissible. No commissioning if condensation present.
Biologically active substances, compliance with EN 60721-3-3	Class 3B2 mold spores, fungal spores (excluding fauna). The supplied plug covers must remain in place over the unused interfaces during operation!
Chemically active substances, compliance with EN 60721-3-3	Class 3C4 incl. salt spray in accordance with EN 60068-2-52 (degree of severity 3). The supplied plug covers must remain in place over the unused interfaces during operation!
Mechanically active substances, compliance with EN 60721-3-3	Class 3S4 incl. sand, dust. The supplied plug covers must remain in place over the unused interfaces during operation!
Air pressure (depending on the highest positive temperature range specified)	1080 ... 795 hPa (-1000 ... +2000 m) see ambient temperature range 795 ... 658 hPa (+2000 ... +3500 m) derating 10 K 658 ... 540 hPa (+3500 ... +5000 m) derating 20 K

For technical documentation on SIPLUS, see:
www.siemens.com/siplus-extreme

Ordering data

Order No.

SIPLUS S7-300 PS 307 load power supply, 5 A

(extended temperature range and medial exposure)

Incl. connection bracket
120/230 V AC; 24 V DC
Output current 5 A
(dimensions 60 x 125 x 120)

6AG1 307-1EA01-7AA0

Accessories

See SITOP power supplies
for S7-300, 24 V DC/5 A,
page 5/243

SIMATIC S7-300

SIPLUS power supplies

SIPLUS S7-300 PS 307, 10 A

Overview



Note:

SIPLUS extreme products are based on Siemens Industry standard products. The contents listed here were taken from the respective standard products. SIPLUS extreme-specific information was added.

SIPLUS S7-300 PS 307, 10 A

Order number	6AG1 307-1KA02-7AA0
Order number based on	6ES7 307-1KA02-0AA0
Conformal coating	Coating of the printed circuit boards and the electronic components
Ambient temperature range	-25 ... +70 °C
Technical data	The technical data of the standard product applies except for the ambient conditions.
Compliant with the standards for electronic equipment used on railway rolling stock (EN 50155, temperature T1, category 1).	No
Ambient conditions	
Relative humidity	100%, condensation/frost permissible. No commissioning if condensation present.
Biologically active substances, compliance with EN 60721-3-3	Class 3B2 mold spores, fungal spores (excluding fauna). The supplied plug covers must remain in place over the unused interfaces during operation!
Chemically active substances, compliance with EN 60721-3-3	Class 3C4 incl. salt spray in accordance with EN 60068-2-52 (degree of severity 3). The supplied plug covers must remain in place over the unused interfaces during operation!
Mechanically active substances, compliance with EN 60721-3-3	Class 3S4 incl. sand, dust. The supplied plug covers must remain in place over the unused interfaces during operation!
Air pressure (depending on the highest positive temperature range specified)	1080 ... 795 hPa (-1000 ... +2000 m) see ambient temperature range 795 ... 658 hPa (+2000 ... +3500 m) derating 10 K 658 ... 540 hPa (+3500 ... +5000 m) derating 20 K

For technical documentation on SIPLUS, see:
www.siemens.com/siplus-extreme

Ordering data

Order No.

SIPLUS S7-300 PS 307 load power supply, 10 A

6AG1 307-1KA02-7AA0

(extended temperature range and medial exposure)

Incl. connection bracket
120/230 V AC; 24 V DC
Output current 10 A
(dimensions 80 x 125 x 120)

Accessories

See SITOP power supplies for S7-300, 24 V DC/10 A, page 5/243

Overview



- The mechanical SIMATIC S7-300 rack
- For accommodating the modules
- Can be attached to walls

Ordering data

DIN rail

160 mm
482 mm
530 mm
830 mm
2000 mm

Order No.

6ES7 390-1AB60-0AA0
6ES7 390-1AE80-0AA0
6ES7 390-1AF30-0AA0
6ES7 390-1AJ30-0AA0
6ES7 390-1BC00-0AA0

SIMATIC S7-300

Accessories

Labeling sheets

Overview

Label sheets

- Film sheets for the application-specific labeling of I/O modules of the SIMATIC S7-300 using standard laser printers
- Plain color films, tear-resistant, dirt-repellent
- Simple handling:
 - perforated label sheets in DIN A4 format for easy separation of the labeling strips.
 - the separated strips can be attached directly onto the I/O modules.
- Different colors to distinguish between different module types or preferred applications:
The label sheets are available in the following colors: petrol, light-beige, red, and yellow. Yellow is reserved for fail-safe systems.

Label cover

- Petrol-colored film
- For sealing and fixing of custom labeling strips on normal paper
- Accessories, 10 units

Technical specifications

Labeling sheets for S7-300

Dimensions	DIN A4
Labeling strips per sheet, pre-perforated	10
Weight, approx.	0.1 kg

Ordering data

Order No.

Label sheets

for modules with 20-pin front connector, DIN A4, for printing with laser printer; 10 units

petrol

6ES7 392-2AX00-0AA0

light-beige

6ES7 392-2BX00-0AA0

yellow

6ES7 392-2CX00-0AA0

red

6ES7 392-2DX00-0AA0

for modules with 40-pin front connector, DIN A4, for printing with laser printer; 10 units

petrol

6ES7 392-2AX10-0AA0

light-beige

6ES7 392-2BX10-0AA0

yellow

6ES7 392-2CX10-0AA0

red

6ES7 392-2DX10-0AA0

SIMATIC S7-400

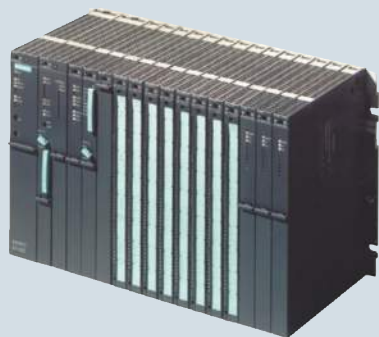
**6/2 Introduction****6/4 Central processing units**

6/4	Standard CPUs
6/4	CPU 412
6/8	CPU 414
6/13	CPU 416
6/18	CPU 417
6/21	SIPLUS Standard CPUs
6/21	SIPLUS CPU 412
6/22	SIPLUS CPU 414
6/23	SIPLUS CPU 416
6/25	SIPLUS CPU 417
6/26	Fail-safe CPUs
6/26	CPU 414F
6/30	CPU 416F
6/35	High-availability CPUs
6/35	CPU 412H
6/35	CPU 414H
6/35	CPU 416H
6/35	CPU 417H
6/41	Sync-module for coupling the CPU 41xH
6/42	Y-link for S7-400H
6/45	SIPLUS high-availability CPUs
6/45	SIPLUS CPU 412H
6/47	SIPLUS CPU 414H
6/49	SIPLUS CPU 417H
6/51	SIPLUS sync module for connecting the CPU 41xH
6/53	SIPLUS Y-Link for S7-400H
6/54	Interface modules PROFIBUS IF-964 DP module
6/55	SIPLUS PROFIBUS IF-964 DP module

6/56 Digital modules

6/56	SM 421 digital input module
6/59	SM 422 digital output module

6/62 SIPLUS digital modules**6/64 Analog modules**

6/64	SM 431 analog input module
6/73	SM 432 analog output module

6/75 SIPLUS analog modules**6/77 Function modules**

6/77	FM 450-1 counter module
6/79	FM 451 positioning module
6/81	FM 452 cam controller
6/83	FM 453 positioning module
6/85	FM 455 controller module
6/90	FM 458-1 DP application module

6/101 SIPLUS function modules**6/103 Communication**

6/103	CP 440
6/104	CP 441-1, CP 441-2
6/106	Loadable drivers for CP 441-2 and CP 341
6/108	CP 443-5 Basic
6/110	CP 443-5 Extended
6/112	CP 443-1
6/115	CP 443-1 Advanced
6/120	SCALANCE M87x UMTS router

6/125 SIPLUS communication**6/128 Connection methods**

6/128	Front connectors
6/129	SIMATIC TOP connect for SIMATIC S7-400

6/131 Racks

6/131	Racks
6/133	Fan subassembly

6/134 SIPLUS racks**6/135 Interface modules**

6/135	IM 460-0
6/136	IM 461-0
6/137	IM 460-1
6/138	IM 461-1
6/139	IM 460-3
6/140	IM 461-3
6/141	IM 463-2

6/142 SIPLUS interface modules**6/144 Power supplies****6/148 SIPLUS power supplies****6/149 Accessories**

6/149	Labeling sheets
6/150	Spare parts

6/151 Modules for SIMATIC S7-400F/FH

6/151	IM 153-1/153-2
6/154	SIPLUS IM 153-1/153-2
6/156	Isolation modules
6/157	SIPLUS isolation modules
6/158	Fail-safe I/O modules

Brochures

For brochures serving as selection guides for SIMATIC products refer to:

<http://www.siemens.com/simatic/printmaterial>

SIMATIC S7-400

Introduction

S7-400/S7-400H/S7-400F/FH

Overview

The S7-400 is the most powerful PLC in the family of SIMATIC controllers. It enables successful automation solutions with Totally Integrated Automation (TIA). The S7-400 is an automation platform for system solutions in production and process engineering, and it is characterized primarily by its modularity and performance reserves.



S7-400H

- Fault-tolerant automation system with redundant design.
- For applications with high fail-safety requirements. Processes with high restart costs, expensive downtimes, little supervision, and few maintenance options.
- Redundant central functions.
- Increases availability of I/O: switched I/O configuration.
- Also possible to use I/Os with standard availability: single-sided configuration.
- Hot stand-by: automatic reaction-free switching to the standby unit in the event of a fault.
- Configuration with two separate or one divided central rack.
- Connection of switched I/O via redundant PROFIBUS DP.

S7-400

- The power PLC for the mid to high-end performance ranges.
- The solution for even the most demanding tasks.
- With a comprehensive range of modules and performance-graded CPUs for optimal adaptation to the automation task.
- Flexible in use through simple implementation of distributed structures; user-friendly connections.
- Optimal communication and networking options.
- User-friendly handling and uncomplicated design without a fan.
- Can be expanded without problems when the tasks increase.
- Multicomputing:
Simultaneous operation of several CPUs in one S7-400 central controller.
Multicomputing distributes the overall performance power of an S7-400. For example, complex tasks can be divided into technologies such as open-loop control, computing or communication, and assigned to different CPUs. And every CPU can be assigned its own local I/O.
- Modularity:
The powerful backplane bus of the S7-400 and the communication interfaces that can be connected direct to the CPU enable high-performance operation of a host of communication lines. This enables, for example, division into one communication path for HMI and programming tasks, one for high-performance and equidistant motion control components, and one for a "normal" I/O fieldbus. Additionally required connections to MES/ERP systems or the Internet can also be implemented.
- Engineering and diagnostics:
The S7-400 is configured and programmed extremely efficiently together with the SIMATIC Engineering Tools particularly in the case of extensive automation solutions with a high engineering component. For this purpose, high-level languages such as SCL and graphical engineering tools for sequential controls, state graph programs and technology-oriented diagrams are available, for example.

Overview (continued)



S7-400F/FH

- Failsafe automation system for plants with increased safety requirements
- Complies with safety requirements to SIL 3 in accordance with IEC 61508, AK6 in accordance with DIN V 19250 and Cat. 4 in accordance with EN 954-1
- If required, also fault tolerant through redundant design
- Without additional wiring of the safety-related I/O:
- Safety-relevant communication via PROFIBUS DP with PROFIsafe profile
- Based on S7-400H and ET 200M with fail-safe modules
- Standard modules for non-safety-related applications can also be used in the automation system
- Isolation module for joint use of fail-safe and standard modules in safety mode in one ET 200M

Technical specifications

General technical data	
Degree of protection	IP20
Ambient temperature	0 to 60 °C
Relative humidity	5 to 95%, no condensation
Atmospheric pressure	1080 to 795 hPa (corresponds to an altitude of 1000 m to 2000 m)
Electromagnetic compatibility	
• Interference immunity	According to EN 61000-6-2
• Emitted interference	According to EN 61000-6-4
Mechanical load	
• Vibration, test according to / tested with	IEC 60068-2-6 (sine) 10 to 58 Hz; constant amplitude 0.075 mm; 58 to 500 Hz; constant acceleration 1 g; duration of oscillation: 10 frequency sweeps per axis in each direction of the three mutually perpendicular axes
• Shock, test according to / tested with	IEC 60068-2-27 Type of shock: Half-sine; strength of the shock 10 g (peak value), duration 6 ms direction of shock: 100 shocks in each of the 3 mutually perpendicular axes.

SIMATIC S7-400

Central processing units

Standard CPUs CPU 412

Overview



- The low-cost starter solution for the medium performance range
- Can be used in small and medium-sized systems with requirements of the medium performance range

Technical specifications

	6ES7 412-1XJ05-0AB0 CPU 412-1	6ES7 412-2XJ05-0AB0 CPU 412-2	6ES7 412-2EK06-0AB0 CPU 412-2 PN
General information			
Engineering with			
• Programming package	STEP7 V 5.3 SP2 or higher with HW update	STEP7 V 5.3 SP2 or higher with HW update	STEP7 V5.5 or higher/iMap V3.0 + iMap STEP7 Add-on V3.0 SP5 or higher
Supply voltage			
24 V DC	No; Power supply via system power supply	No; Power supply via system power supply	No; Power supply via system power supply
Power losses			
Power loss, typ.	2.5 W	4.5 W	5.5 W
Memory			
Work memory			
• integrated	288 kbyte	512 kbyte	1 Mbyte
• integrated (for program)	144 kbyte	256 kbyte	0.5 Mbyte
• integrated (for data)	144 kbyte	256 kbyte	0.5 Mbyte
Load memory			
• expandable FEPRAM, max.	64 Mbyte	64 Mbyte	64 Mbyte
• integrated RAM, max.	512 kbyte	512 kbyte	512 kbyte
• expandable RAM, max.	64 Mbyte	64 Mbyte	64 Mbyte
CPU processing times			
for bit operations, typ.	75 ns	75 ns	75 ns
for word operations, typ.	75 ns	75 ns	75 ns
for fixed point arithmetic, typ.	75 ns	75 ns	75 ns
for floating point arithmetic, typ.	225 ns	225 ns	225 ns
Counters, timers and their retentivity			
S7 counter			
• Number	2 048	2 048	2 048
IEC counter			
• present	Yes	Yes	Yes
S7 times			
• Number	2 048	2 048	2 048
IEC timer			
• present	Yes	Yes	Yes

Technical specifications (continued)

	6ES7 412-1XJ05-0AB0 CPU 412-1	6ES7 412-2XJ05-0AB0 CPU 412-2	6ES7 412-2EK06-0AB0 CPU 412-2 PN
Data areas and their retentivity			
Flag			
• Number, max.	4 kbyte; Size of bit memory address area	4 kbyte; Size of bit memory address area	4 kbyte; Size of bit memory address area
Address area			
I/O address area			
• Inputs	4 kbyte	4 kbyte	4 kbyte
• Outputs	4 kbyte	4 kbyte	4 kbyte
Process image			
• Inputs, adjustable	4 kbyte	4 kbyte	4 kbyte
• Outputs, adjustable	4 kbyte	4 kbyte	4 kbyte
Time of day			
Clock			
• Hardware clock (real-time clock)	Yes	Yes	Yes
Operating hours counter			
• Number	16	16	16
1st interface			
Type of interface	integrated	integrated	integrated
Physics	RS 485 / PROFIBUS + MPI	RS 485 / PROFIBUS + MPI	RS 485 / PROFIBUS + MPI
Functionality			
• MPI	Yes	Yes	Yes
• DP master	Yes	Yes	Yes
• DP slave	Yes	Yes	Yes
DP master			
• Number of DP slaves, max.	32	32	32
2nd interface			
Type of interface		integrated	PROFINET
Physics		RS 485 / PROFIBUS	Ethernet RJ45
Number of ports			2
Functionality			
• DP master		Yes	No
• DP slave		Yes	No
• PROFINET IO Controller			Yes
• PROFINET IO Device			Yes
• PROFINET CBA			Yes
DP master			
• Number of DP slaves, max.		64	
PROFINET IO Controller			
• Max. number of connectable IO devices for RT			256
• Number of IO devices with IRT and the option "high flexibility"			256
• Number of IO Devices with IRT and the option "high performance", max.			64
Isochronous mode			
Isochronous operation (application synchronized up to terminal)	Yes; For PROFIBUS only	Yes; For PROFIBUS only	Yes; Via PROFIBUS DP or PROFINET interface

SIMATIC S7-400

Central processing units

Standard CPUs

CPU 412

Technical specifications (continued)

	6ES7 412-1XJ05-0AB0 CPU 412-1	6ES7 412-2XJ05-0AB0 CPU 412-2	6ES7 412-2EK06-0AB0 CPU 412-2 PN
Communication functions			
PG/OP communication	Yes	Yes	Yes
Data record routing	Yes	Yes	Yes
Global data communication			
• supported	Yes	Yes	Yes
S7 basic communication			
• supported	Yes	Yes	Yes
S7 communication			
• supported	Yes	Yes	Yes
S5-compatible communication			
• supported	Yes; Via FC AG_SEND and AG_RECV, max. via 10 CP 443-1 or 443-5	Yes; Via FC AG_SEND and AG_RECV, max. via 10 CP 443-1 or 443-5	Yes; Via FC AG_SEND and AG_RECV, max. via 10 CP 443-1 or 443-5
Standard communication (FMS)			
• supported	Yes; Via CP and loadable FB	Yes; Via CP and loadable FB	Yes; Via CP and loadable FB
Open IE communication			
• TCP/IP			Yes; via integrated PROFINET interface and loadable FBs 46
- Number of connections, max.			46
• ISO-on-TCP (RFC1006)	Via CP 443-1 Adv. and loadable FB	Via CP 443-1 and loadable FB	Yes; Via integrated PROFINET interface or CP 443-1 Adv. and loadable FBs 46
- Number of connections, max.			46
• UDP			Yes; via integrated PROFINET interface and loadable FBs 46
- Number of connections, max.			46
Web server			
• supported	No	No	Yes
Number of connections			
• overall	32	32	48
Configuration			
programming			
• Programming language			
- LAD	Yes	Yes	Yes
- FBD	Yes	Yes	Yes
- STL	Yes	Yes	Yes
- SCL	Yes	Yes	Yes
- CFC	Yes	Yes	Yes
- GRAPH	Yes	Yes	Yes
- HiGraph®	Yes	Yes	Yes
Know-how protection			
• User program protection/password protection	Yes	Yes	Yes
• Block encryption			Yes; With S7 block Privacy
Dimensions			
Width	25 mm	25 mm	25 mm
Height	290 mm	290 mm	290 mm
Depth	219 mm	219 mm	219 mm
Required slots	1	1	1
Weight			
Weight, approx.	0.7 kg	0.7 kg	750 g

SIMATIC S7-400

Central processing units

Standard CPUs
CPU 412

Ordering data	Order No.	Order No.
CPU 412-1 Main memory 288 KB, power supply 24 V DC, MPI/PROFIBUS DP master interface, slot for memory card, incl. slot number labels	6ES7 412-1XJ05-0AB0	SIMATIC Manual Collection Electronic manuals on DVD, multilingual: LOGO!, SIMADYN, SIMATIC bus components, SIMATIC C7, SIMATIC distributed I/O, SIMATIC HMI, SIMATIC Sensors, SIMATIC NET, SIMATIC PC Based Automation, SIMATIC PCS 7, SIMATIC PG/PC, SIMATIC S7, SIMATIC Software, SIMATIC TDC
CPU 412-2 Main memory 512 KB, power supply 24 V DC, MPI/PROFIBUS DP master interface, slot for memory card, incl. slot number labels	6ES7 412-2XJ05-0AB0	6ES7 998-8XC01-8YE0
CPU 412-2 PN Main memory 1 MB, power supply 24 V DC, MPI/PROFIBUS DP master interface, PROFINET interface, slot for memory card, incl. slot number labels	6ES7 412-2EK06-0AB0	SIMATIC Manual Collection update service for 1 year Current "Manual Collection" DVD and the three subsequent updates
Memory card RAM 64 KB 256 KB 1 MB 2 MB 4 MB 8 MB 16 MB 64 MB	6ES7 952-0AF00-0AA0 6ES7 952-1AH00-0AA0 6ES7 952-1AK00-0AA0 6ES7 952-1AL00-0AA0 6ES7 952-1AM00-0AA0 6ES7 952-1AP00-0AA0 6ES7 952-1AS00-0AA0 6ES7 952-1AY00-0AA0	RS 485 bus connector with 90° cable outlet Max. transfer rate 12 Mbit/s Without PG interface 6ES7 972-0BA12-0XA0 With PG interface 6ES7 972-0BB12-0XA0
FEPR0M memory card 64 KB 256 KB 1 MB 2 MB 4 MB 8 MB 16 MB 32 MB 64 MB	6ES7 952-0KF00-0AA0 6ES7 952-0KH00-0AA0 6ES7 952-1KK00-0AA0 6ES7 952-1KL00-0AA0 6ES7 952-1KM00-0AA0 6ES7 952-1KP00-0AA0 6ES7 952-1KS00-0AA0 6ES7 952-1KT00-0AA0 6ES7 952-1KY00-0AA0	RS 485 bus connector with angled cable outlet Max. transfer rate 12 Mbit/s Without PG interface 6ES7 972-0BA42-0XA0 With PG interface 6ES7 972-0BB42-0XA0
MPI cable for connection of SIMATIC S7 and PG via MPI; 5 m in length	6ES7 901-0BF00-0AA0	RS 485 bus connector with 90° cable outlet for FastConnect connection system Max. transfer rate 12 Mbit/s Without PG interface • 1 unit 6ES7 972-0BA52-0XA0 • 100 units 6ES7 972-0BA52-0XB0 With PG interface • 1 unit 6ES7 972-0BB52-0XA0 • 100 units 6ES7 972-0BB52-0XB0
Slot number plates 1 set (spare part)	6ES7 912-0AA00-0AA0	RS 485 bus connector with axial cable outlet For SIMATIC OP, for connection to PPI, MPI, PROFIBUS 6GK1 500-0EA02
		PROFIBUS FastConnect bus cable Standard type with special design for quick mounting, 2-core, shielded, sold by the meter, max. delivery unit 1000 m, minimum ordering quantity 20 m 6XV1 830-0EH10

SIMATIC S7-400

Central processing units

Standard CPUs
CPU 414

Overview



- CPUs for high demands in the mid-level performance range
- Applicable for plants with additional demands on programming scope and processing speed
- Integrated PROFINET functions in CPU 414-3 PN/DP

Technical specifications

	6ES7 414-2XK05-0AB0 CPU 414-2	6ES7 414-3XM05-0AB0 CPU 414-3	6ES7 414-3EM06-0AB0 CPU 414-3 PN/DP
General information Engineering with • Programming package	STEP7 V 5.3 SP2 or higher with HW update	STEP7 V 5.3 SP2 or higher with HW update	STEP7 V5.5 or higher/iMap V3.0 + iMap STEP7 Add-on V3.0 SP5 or higher
Supply voltage 24 V DC	No; Power supply via system power supply	No; Power supply via system power supply	No; Power supply via system power supply
Power losses Power loss, typ.	4.5 W	5.5 W	6.5 W
Memory Work memory • integrated • integrated (for program) • integrated (for data)	1 Mbyte 0.5 Mbyte 0.5 Mbyte	2.8 Mbyte 1.4 Mbyte 1.4 Mbyte	4 Mbyte 2 Mbyte 2 Mbyte
Load memory • expandable FEPRAM, max. • integrated RAM, max. • expandable RAM, max.	64 Mbyte 512 kbyte 64 Mbyte	64 Mbyte 512 kbyte 64 Mbyte	64 Mbyte 512 kbyte 64 Mbyte
CPU processing times for bit operations, typ.	45 ns	45 ns	45 ns
for word operations, typ.	45 ns	45 ns	45 ns
for fixed point arithmetic, typ.	45 ns	45 ns	45 ns
for floating point arithmetic, typ.	135 ns	135 ns	135 ns
Counters, timers and their retentivity S7 counter • Number	2 048	2 048	2 048
IEC counter • present	Yes	Yes	Yes
S7 times • Number	2 048	2 048	2 048
IEC timer • present	Yes	Yes	Yes

6

Technical specifications (continued)

	6ES7 414-2XK05-0AB0 CPU 414-2	6ES7 414-3XM05-0AB0 CPU 414-3	6ES7 414-3EM06-0AB0 CPU 414-3 PN/DP
Data areas and their retentivity			
Flag			
• Number, max.	8 kbyte; Size of bit memory address area	8 kbyte; Size of bit memory address area	8 kbyte; Size of bit memory address area
Address area			
I/O address area			
• Inputs	8 kbyte	8 kbyte	8 kbyte
• Outputs	8 kbyte	8 kbyte	8 kbyte
Process image			
• Inputs, adjustable	8 kbyte	8 kbyte	8 kbyte
• Outputs, adjustable	8 kbyte	8 kbyte	8 kbyte
Time of day			
Clock			
• Hardware clock (real-time clock)	Yes	Yes	Yes
Operating hours counter			
• Number	16	16	16
1st interface			
Type of interface	integrated	integrated	integrated
Physics	RS 485 / PROFIBUS + MPI	RS 485 / PROFIBUS + MPI	RS 485 / PROFIBUS + MPI
Functionality			
• MPI	Yes	Yes	Yes
• DP master	Yes	Yes	Yes
• DP slave	Yes	Yes	Yes
DP master			
• Number of DP slaves, max.	32	32	32
2nd interface			
Type of interface	integrated	integrated	PROFINET
Physics	RS 485 / PROFIBUS	RS 485 / PROFIBUS	Ethernet RJ45
Number of ports			2
Functionality			
• DP master	Yes	Yes	No
• DP slave	Yes	Yes	No
• PROFINET IO Controller			Yes
• PROFINET IO Device			Yes
• PROFINET CBA			Yes
DP master			
• Number of DP slaves, max.	96	96	
PROFINET IO Controller			
• Max. number of connectable IO devices for RT			256
• Number of IO devices with IRT and the option "high flexibility"			256
• Number of IO Devices with IRT and the option "high performance", max.			64
3rd interface			
Type of interface		Pluggable interface module (IF), technical data as for 2nd interface	Pluggable interface module (IF)
Plug-in interface modules		IF 964-DP (MLFB: 6ES7964-2AA04-0AB0)	IF 964-DP (MLFB: 6ES7964-2AA04-0AB0)
Physics		RS 485 / PROFIBUS	RS 485 / PROFIBUS
Functionality			
• MPI		No	No
• DP master		Yes	Yes
• DP slave		Yes	Yes
DP master			
• Number of DP slaves, max.		96	96

SIMATIC S7-400

Central processing units

Standard CPUs

CPU 414

Technical specifications (continued)

	6ES7 414-2XK05-0AB0 CPU 414-2	6ES7 414-3XM05-0AB0 CPU 414-3	6ES7 414-3EM06-0AB0 CPU 414-3 PN/DP
Isochronous mode			
Isochronous operation (application synchronized up to terminal)	Yes; For PROFIBUS only	Yes; For PROFIBUS only	Yes; Via PROFIBUS DP or PROFINET interface
Communication functions			
PG/OP communication	Yes	Yes	Yes
Data record routing	Yes	Yes	Yes
Global data communication			
• supported	Yes	Yes	Yes
S7 basic communication			
• supported	Yes	Yes	Yes
S7 communication			
• supported	Yes	Yes	Yes
S5-compatible communication			
• supported	Yes; Via FC AG_SEND and AG_RECV, max. via 10 CP 443-1 or 443-5	Yes; Via FC AG_SEND and AG_RECV, max. via 10 CP 443-1 or 443-5	Yes; Via FC AG_SEND and AG_RECV, max. via 10 CP 443-1 or 443-5
Standard communication (FMS)			
• supported	Yes; Via CP and loadable FB	Yes; Via CP and loadable FB	Yes; Via CP and loadable FB
Open IE communication			
• TCP/IP			Yes; via integrated PROFINET interface and loadable FBs 62
- Number of connections, max.			Yes; Via integrated PROFINET interface or CP 443-1 Adv. and loadable FBs 62
• ISO-on-TCP (RFC1006)	Via CP 443-1 and loadable FB	Via CP 443-1 and loadable FB	Yes; via integrated PROFINET interface and loadable FBs 62
- Number of connections, max.			62
• UDP			Yes; via integrated PROFINET interface and loadable FBs 62
- Number of connections, max.			62
Web server			
• supported	No	No	Yes
Number of connections			
• overall	32	32	64
Configuration			
programming			
• Programming language			
- LAD	Yes	Yes	Yes
- FBD	Yes	Yes	Yes
- STL	Yes	Yes	Yes
- SCL	Yes	Yes	Yes
- CFC	Yes	Yes	Yes
- GRAPH	Yes	Yes	Yes
- HiGraph®	Yes	Yes	Yes
Know-how protection			
• User program protection/password protection	Yes	Yes	Yes
• Block encryption			Yes; With S7 block Privacy
Dimensions			
Width	25 mm	50 mm	50 mm
Height	290 mm	290 mm	290 mm
Depth	219 mm	219 mm	219 mm
Required slots	1	2	2
Weight			
Weight, approx.	0.7 kg	0.9 kg	900 g

SIMATIC S7-400

Central processing units

Standard CPUs
CPU 414

Ordering data	Order No.	Order No.
CPU 414-2 Main memory 1 MB, power supply 24 V DC, MPI/PROFIBUS DP master interface, slot for memory card, incl. slot number labels	6ES7 414-2XK05-0AB0	Slot number plates 1 set (spare part)
CPU 414-3 Main memory 2.8 MB, power supply 24 V DC, MPI/PROFIBUS DP master interface, PROFIBUS DP master interface, slot for memory card, module slots for 1 IF module, incl. slot number labels	6ES7 414-3XM05-0AB0	SIMATIC Manual Collection Electronic manuals on DVD, multilingual: LOGO!, SIMADYN, SIMATIC bus components, SIMATIC C7, SIMATIC distributed I/O, SIMATIC HMI, SIMATIC Sensors, SIMATIC NET, SIMATIC PC Based Automation, SIMATIC PCS 7, SIMATIC PG/PC, SIMATIC S7, SIMATIC Software, SIMATIC TDC
CPU 414-3 PN/DP Main memory 4 MB, power supply 24 V DC, MPI/PROFIBUS DP master interface, PROFINET interface, slot for memory card, module slot for 1 IF module, incl. slot number labels	6ES7 414-3EM06-0AB0	SIMATIC Manual Collection update service for 1 year Current "Manual Collection" DVD and the three subsequent updates
Memory card RAM 64 KB 256 KB 1 MB 2 MB 4 MB 8 MB 16 MB 64 MB	6ES7 952-0AF00-0AA0 6ES7 952-1AH00-0AA0 6ES7 952-1AK00-0AA0 6ES7 952-1AL00-0AA0 6ES7 952-1AM00-0AA0 6ES7 952-1AP00-0AA0 6ES7 952-1AS00-0AA0 6ES7 952-1AY00-0AA0	PROFIBUS bus components RS 485 bus connector with 90° cable outlet Max. transfer rate 12 Mbit/s Without PG interface With PG interface
FEPRM memory card 64 KB 256 KB 1 MB 2 MB 4 MB 8 MB 16 MB 32 MB 64 MB	6ES7 952-0KF00-0AA0 6ES7 952-0KH00-0AA0 6ES7 952-1KK00-0AA0 6ES7 952-1KL00-0AA0 6ES7 952-1KM00-0AA0 6ES7 952-1KP00-0AA0 6ES7 952-1KS00-0AA0 6ES7 952-1KT00-0AA0 6ES7 952-1KY00-0AA0	RS 485 bus connector with angled cable outlet Max. transfer rate 12 Mbit/s Without PG interface With PG interface
MPI cable For connection of SIMATIC S7 and PG via MPI; 5 m in length	6ES7 901-0BF00-0AA0	RS 485 bus connector with 90° cable outlet for FastConnect connection system Max. transfer rate 12 Mbit/s Without PG interface • 1 unit • 100 units With PG interface • 1 unit • 100 units
IF 964-DP interface module To connect an additional DP line; for CPU 414-3, CPU 414-3 PN/DP, CPU 416-3, CPU 416-3 PN/DP, CPU 417-4	6ES7 964-2AA04-0AB0	RS 485 bus connector with axial cable outlet For SIMATIC OP, for connection to PPI, MPI, PROFIBUS
		PROFIBUS FastConnect bus cable Standard type with special design for quick mounting, 2-core, shielded, sold by the meter, max. delivery unit 1000 m, minimum ordering quantity 20 m
		RS 485 repeater for PROFIBUS Transmission rate up to 12 Mbit/s; 24 V DC; IP20 enclosure

SIMATIC S7-400

Central processing units

Standard CPUs
CPU 414

Ordering data	Order No.		Order No.
PROFINET bus components			
IE FC TP standard cable GP 2x2 4-core, shielded TP installation cable for connection to IE FC Outlet RJ45/ IE FC RJ45 Plug; PROFINET-compatible; with UL approval; Sold by the meter	6XV1 840-2AH10	IE FC RJ45 plugs RJ45 plug connector for Industrial Ethernet with a rugged metal enclosure and integrated insulation displacement contacts for connecting Industrial Ethernet FC installation cables	
FO Standard Cable GP (50/125) Standard cable, splittable, UL approval, sold by the meter	6XV1 873-2A	IE FC RJ45 plug 180 180° cable outlet 1 unit 10 units 50 units	6GK1 901-1BB10-2AA0 6GK1 901-1BB10-2AB0 6GK1 901-1BB10-2AE0
SCALANCE X204-2 Industrial Ethernet switch Industrial Ethernet Switches with integral SNMP access, web diagnostics, copper cable diagnostics and PROFINET diagnostics for configuring line, star and ring topologies; four 10/100 Mbit/s RJ45 ports and two FO ports	6GK5 204-2BB10-2AA3	PROFIBUS/PROFINET bus components For establishing MPI/PROFIBUS/PROFINET communication	See IK PI, CA 01 catalogs

6

Overview



- High-performance CPUs in the high-end performance range
- Applicable for plants with high requirements in the high-end performance range
- Integrated PROFINET functions in CPU 416-3 PN/DP

Technical specifications

	6ES7 416-2XN05-0AB0 CPU 416-2	6ES7 416-3XR05-0AB0 CPU 416-3	6ES7 416-3ES06-0AB0 CPU416-3 PN/DP
General information Engineering with • Programming package	STEP7 V 5.3 SP2 or higher with HW update	STEP7 V 5.3 SP2 or higher with HW update	STEP7 V5.5 or higher/iMap V3.0 + iMap STEP7 Add-on V3.0 SP5 or higher
Supply voltage 24 V DC	No; Power supply via system power supply	No; Power supply via system power supply	No; Power supply via system power supply
Power losses Power loss, typ.	4.5 W	5.5 W	6.5 W
Memory Work memory • integrated • integrated (for program) • integrated (for data)	5.6 Mbyte 2.8 Mbyte 2.8 Mbyte	11.2 Mbyte 5.6 Mbyte 5.6 Mbyte	16 Mbyte 8 Mbyte 8 Mbyte
Load memory • expandable FEPRM, max. • integrated RAM, max. • expandable RAM, max.	64 Mbyte 1 Mbyte 64 Mbyte	64 Mbyte 1 Mbyte 64 Mbyte	64 Mbyte 1 Mbyte 64 Mbyte
CPU processing times for bit operations, typ.	30 ns	30 ns	30 ns
for word operations, typ.	30 ns	30 ns	30 ns
for fixed point arithmetic, typ.	30 ns	30 ns	30 ns
for floating point arithmetic, typ.	90 ns	90 ns	90 ns
Counters, timers and their retentivity S7 counter • Number	2 048	2 048	2 048
IEC counter • present	Yes	Yes	Yes
S7 times • Number	2 048	2 048	2 048
IEC timer • present	Yes	Yes	Yes

SIMATIC S7-400

Central processing units

Standard CPUs

CPU 416

Technical specifications (continued)

	6ES7 416-2XN05-0AB0 CPU 416-2	6ES7 416-3XR05-0AB0 CPU 416-3	6ES7 416-3ES06-0AB0 CPU416-3 PN/DP
Data areas and their retentivity			
Flag			
• Number, max.	16 kbyte; Size of bit memory address area	16 kbyte; Size of bit memory address area	16 kbyte; Size of bit memory address area
Address area			
I/O address area			
• Inputs	16 kbyte	16 kbyte	16 kbyte
• Outputs	16 kbyte	16 kbyte	16 kbyte
Process image			
• Inputs, adjustable	16 kbyte	16 kbyte	16 kbyte
• Outputs, adjustable	16 kbyte	16 kbyte	16 kbyte
Time of day			
Clock			
• Hardware clock (real-time clock)	Yes	Yes	Yes
Operating hours counter			
• Number	16	16	16
1st interface			
Type of interface	integrated	integrated	integrated
Physics	RS 485 / PROFIBUS + MPI	RS 485 / PROFIBUS + MPI	RS 485 / PROFIBUS + MPI
Functionality			
• MPI	Yes	Yes	Yes
• DP master	Yes	Yes	Yes
• DP slave	Yes	Yes	Yes
DP master			
• Number of DP slaves, max.	32	32	32
2nd interface			
Type of interface	integrated	integrated	PROFINET
Physics	RS 485 / PROFIBUS	RS 485 / PROFIBUS	Ethernet RJ45
Number of ports			2
Functionality			
• DP master	Yes	Yes	No
• DP slave	Yes	Yes	No
• PROFINET IO Controller			Yes
• PROFINET IO Device			Yes
• PROFINET CBA			Yes
DP master			
• Number of DP slaves, max.	125	125	
PROFINET IO Controller			
• Max. number of connectable IO devices for RT			256
• Number of IO devices with IRT and the option "high flexibility"			256
• Number of IO Devices with IRT and the option "high performance", max.			64
3rd interface			
Type of interface		Pluggable interface module (IF), technical data as for 2nd interface	Pluggable interface module (IF)
Plug-in interface modules		IF 964-DP (MLFB: 6ES7964-2AA04-0AB0)	IF 964-DP (MLFB: 6ES7964-2AA04-0AB0)
Physics		RS 485 / PROFIBUS	RS 485 / PROFIBUS
Functionality			
• MPI		No	No
• DP master		Yes	Yes
• DP slave		Yes	Yes
DP master			
• Number of DP slaves, max.		125	125

Technical specifications (continued)

	6ES7 416-2XN05-0AB0 CPU 416-2	6ES7 416-3XR05-0AB0 CPU 416-3	6ES7 416-3ES06-0AB0 CPU416-3 PN/DP
Isochronous mode			
Isochronous operation (application synchronized up to terminal)	Yes; For PROFIBUS only	Yes; For PROFIBUS only	Yes; Via PROFIBUS DP or PROFINET interface
Communication functions			
PG/OP communication	Yes	Yes	Yes
Data record routing	Yes	Yes	Yes
Global data communication			
• supported	Yes	Yes	Yes
S7 basic communication			
• supported	Yes	Yes	Yes
S7 communication			
• supported	Yes	Yes	Yes
S5-compatible communication			
• supported	Yes; Via FC AG_SEND and AG_RECV, max. via 10 CP 443-1 or 443-5	Yes; Via FC AG_SEND and AG_RECV, max. via 10 CP 443-1 or 443-5	Yes; Via FC AG_SEND and AG_RECV, max. via 10 CP 443-1 or 443-5
Standard communication (FMS)			
• supported	Yes; Via CP and loadable FB	Yes; Via CP and loadable FB	Yes; Via CP and loadable FB
Open IE communication			
• TCP/IP			Yes; via integrated PROFINET interface and loadable FBs 94
- Number of connections, max.			94
• ISO-on-TCP (RFC1006)	Via CP 443-1 and loadable FB	Via CP 443-1 and loadable FB	Yes; Via integrated PROFINET interface or CP 443-1 and loadable FBs 94
- Number of connections, max.			94
• UDP			Yes; via integrated PROFINET interface and loadable FBs 94
- Number of connections, max.			94
Web server			
• supported	No	No	Yes
Number of connections			
• overall	64	64	96
Configuration			
programming			
• Programming language			
- LAD	Yes	Yes	Yes
- FBD	Yes	Yes	Yes
- STL	Yes	Yes	Yes
- SCL	Yes	Yes	Yes
- CFC	Yes	Yes	Yes
- GRAPH	Yes	Yes	Yes
- HiGraph®	Yes	Yes	Yes
Know-how protection			
• User program protection/password protection	Yes	Yes	Yes
• Block encryption			Yes; With S7 block Privacy
Dimensions			
Width	25 mm	50 mm	50 mm
Height	290 mm	290 mm	290 mm
Depth	219 mm	219 mm	219 mm
Required slots	1	2	2
Weight			
Weight, approx.	0.7 kg	0.9 kg	900 g

SIMATIC S7-400

Central processing units

Standard CPUs CPU 416

Ordering data	Order No.	Order No.
CPU 416-2 Main memory 5.6 MB, power supply 24 V DC, MPI/PROFIBUS DP master interface, PROFIBUS DP master interface, slot for memory card, incl. slot number labels	6ES7 416-2XN05-0AB0	Slot number plates 1 set (spare part)
CPU 416-3 Main memory 11.2 MB, power supply 24 V DC, MPI/PROFIBUS DP master interface, PROFIBUS DP master interface, module slot for 1 IF module, slot for memory card, incl. slot number labels	6ES7 416-3XR05-0AB0	SIMATIC Manual Collection Electronic manuals on DVD, multilingual: LOGO!, SIMADYN, SIMATIC bus components, SIMATIC C7, SIMATIC distributed I/O, SIMATIC HMI, SIMATIC Sensors, SIMATIC NET, SIMATIC PC Based Automation, SIMATIC PCS 7, SIMATIC PG/PC, SIMATIC S7, SIMATIC Software, SIMATIC TDC
CPU 416-3 PN/DP Main memory 16 MB, power supply 24 V DC, MPI/PROFIBUS DP master interface, PROFINET interface, module slot for 1 IF submodule, slot for memory card, incl. slot number labels	6ES7 416-3ES06-0AB0	SIMATIC Manual Collection update service for 1 year Current "Manual Collection" DVD and the three subsequent updates
Memory card RAM 64 KB 256 KB 1 MB 2 MB 4 MB 8 MB 16 MB 64 MB	6ES7 952-0AF00-0AA0 6ES7 952-1AH00-0AA0 6ES7 952-1AK00-0AA0 6ES7 952-1AL00-0AA0 6ES7 952-1AM00-0AA0 6ES7 952-1AP00-0AA0 6ES7 952-1AS00-0AA0 6ES7 952-1AY00-0AA0	PROFIBUS bus components RS 485 bus connector with 90° cable outlet Max. transfer rate 12 Mbit/s Without PG interface With PG interface
FEPRM memory card 64 KB 256 KB 1 MB 2 MB 4 MB 8 MB 16 MB 32 MB 64 MB	6ES7 952-0KF00-0AA0 6ES7 952-0KH00-0AA0 6ES7 952-1KK00-0AA0 6ES7 952-1KL00-0AA0 6ES7 952-1KM00-0AA0 6ES7 952-1KP00-0AA0 6ES7 952-1KS00-0AA0 6ES7 952-1KT00-0AA0 6ES7 952-1KY00-0AA0	RS 485 bus connector with angled cable outlet Max. transfer rate 12 Mbit/s Without PG interface With PG interface
MPI cable for connection of SIMATIC S7 and PG via MPI; 5 m in length	6ES7 901-0BF00-0AA0	RS 485 bus connector with 90° cable outlet for FastConnect connection system Max. transfer rate 12 Mbit/s Without PG interface • 1 unit • 100 units With PG interface • 1 unit • 100 units
IF 964-DP interface module To connect an additional DP line; for CPU 414-3, CPU 414-3 PN/DP, CPU 416-3, CPU 416-3 PN/DP, CPU 417-4	6ES7 964-2AA04-0AB0	RS 485 bus connector with axial cable outlet For SIMATIC OP, for connection to PPI, MPI, PROFIBUS
		PROFIBUS FastConnect bus cable Standard type with special design for quick mounting, 2-core, shielded, sold by the meter, max. delivery unit 1000 m, minimum ordering quantity 20 m
		RS 485 repeater for PROFIBUS Transmission rate up to 12 Mbit/s; 24 V DC; IP20 enclosure

SIMATIC S7-400

Central processing units

Standard CPUs
CPU 416

Ordering data	Order No.	Order No.
PROFINET bus components		
IE FC TP standard cable GP 2x2 4-core, shielded TP installation cable for connection to IE FC Outlet RJ45/ IE FC RJ45 Plug; PROFINET-compatible; with UL approval; Sold by the meter	6XV1 840-2AH10	
FO Standard Cable GP (50/125) Standard cable, splittable, UL approval, sold by the meter	6XV1 873-2A	
SCALANCE X204-2 Industrial Ethernet switch Industrial Ethernet Switches with integral SNMP access, web diagnostics, copper cable diagnostics and PROFINET diagnostics for configuring line, star and ring topologies; four 10/100 Mbit/s RJ45 ports and two FO ports	6GK5 204-2BB10-2AA3	
		IE FC RJ45 plugs RJ45 plug connector for Industrial Ethernet with a rugged metal enclosure and integrated insulation displacement contacts for connecting Industrial Ethernet FC installation cables
		IE FC RJ45 plug 180 180° cable outlet 1 unit 10 units 50 units
		PROFIBUS/PROFINET bus components For establishing MPI/PROFIBUS/PROFINET communication
		6GK1 901-1BB10-2AA0 6GK1 901-1BB10-2AB0 6GK1 901-1BB10-2AE0 See IK PI, CA 01 catalogs

SIMATIC S7-400

Central processing units

Standard CPUs
CPU 417

Overview



- The most powerful SIMATIC S7-400 CPU
- Can be used in the most sophisticated installations in the upper performance range
- With two slots for IF modules

Technical specifications

6ES7 417-4XT05-0AB0 CPU 417-4	
General information	
Engineering with	
• Programming package	STEP7 V 5.3 SP2 or higher with HW update
Supply voltage	
24 V DC	No; Power supply via system power supply
Power losses	
Power loss, typ.	7.5 W
Memory	
Work memory	
• integrated	30 Mbyte
• integrated (for program)	15 Mbyte
• integrated (for data)	15 Mbyte
Load memory	
• expandable FEPRAM, max.	64 Mbyte
• integrated RAM, max.	1 Mbyte
• expandable RAM, max.	64 Mbyte
CPU processing times	
for bit operations, typ.	18 ns
for word operations, typ.	18 ns
for fixed point arithmetic, typ.	18 ns
for floating point arithmetic, typ.	54 ns
Counters, timers and their retentivity	
S7 counter	
• Number	2 048
IEC counter	
• present	Yes
S7 times	
• Number	2 048
IEC timer	
• present	Yes

6ES7 417-4XT05-0AB0 CPU 417-4	
Data areas and their retentivity	
Flag	
• Number, max.	16 kbyte; Size of bit memory address area
Address area	
I/O address area	
• Inputs	16 kbyte
• Outputs	16 kbyte
Process image	
• Inputs, adjustable	16 kbyte
• Outputs, adjustable	16 kbyte
Time of day	
Clock	
• Hardware clock (real-time clock)	Yes
Operating hours counter	
• Number	16
1st interface	
Type of interface	integrated
Physics	RS 485 / PROFIBUS + MPI
Functionality	
• MPI	Yes
• DP master	Yes
• DP slave	Yes
DP master	
• Number of DP slaves, max.	32
2nd interface	
Type of interface	integrated
Physics	RS 485 / PROFIBUS
Functionality	
• DP master	Yes
• DP slave	Yes
DP master	
• Number of DP slaves, max.	125

6

Technical specifications (continued)

6ES7 417-4XT05-0AB0 CPU 417-4	
3rd interface	
Type of interface	Pluggable interface module (IF), technical data as for 2nd interface
Plug-in interface modules	IF 964-DP (MLFB: 6ES7964-2AA04-0AB0)
Physics	RS 485 / PROFIBUS
Functionality	
• MPI	No
• DP master	Yes
• DP slave	Yes
DP master	
• Number of DP slaves, max.	125
4th interface	
Type of interface	Pluggable interface module (IF), technical data as for 2nd interface
Plug-in interface modules	IF 964-DP (MLFB: 6ES7964-2AA04-0AB0)
Isochronous mode	
Isochronous operation (application synchronized up to terminal)	Yes; For PROFIBUS only
Communication functions	
PG/OP communication	Yes
Data record routing	Yes
Global data communication	
• supported	Yes
S7 basic communication	
• supported	Yes
S7 communication	
• supported	Yes
S5-compatible communication	
• supported	Yes; Via FC AG_SEND and AG_RECV, max. via 10 CP 443-1 or 443-5
Standard communication (FMS)	
• supported	Yes; Via CP and loadable FB
Open IE communication	
• ISO-on-TCP (RFC1006)	Via CP 443-1 and loadable FB
Web server	
• supported	No
Number of connections	
• overall	64

6ES7 417-4XT05-0AB0 CPU 417-4	
Configuration	
programming	
• Programming language	
- LAD	Yes
- FBD	Yes
- STL	Yes
- SCL	Yes
- CFC	Yes
- GRAPH	Yes
- HiGraph®	Yes
Know-how protection	
• User program protection/password protection	Yes
Dimensions	
Width	50 mm
Height	290 mm
Depth	219 mm
Required slots	2
Weight	
Weight, approx.	0.9 kg

SIMATIC S7-400

Central processing units

Standard CPUs CPU 417

Ordering data	Order No.	Order No.	
CPU 417-4 Main memory 30 MB, power supply 24 V DC, MPI/PROFIBUS DP master interface, PROFIBUS DP master interface, module slots for up to 2 additional IF modules, slot for memory card, incl. slot number labels	6ES7 417-4XT05-0AB0	SIMATIC Manual Collection Electronic manuals on DVD, multilingual: LOGO!, SIMADYN, SIMATIC bus components, SIMATIC C7, SIMATIC distributed I/O, SIMATIC HMI, SIMATIC Sensors, SIMATIC NET, SIMATIC PC Based Automation, SIMATIC PCS 7, SIMATIC PG/PC, SIMATIC S7, SIMATIC Software, SIMATIC TDC	6ES7 998-8XC01-8YE0
Memory card RAM 64 KB 256 KB 1 MB 2 MB 4 MB 8 MB 16 MB 64 MB	6ES7 952-0AF00-0AA0 6ES7 952-1AH00-0AA0 6ES7 952-1AK00-0AA0 6ES7 952-1AL00-0AA0 6ES7 952-1AM00-0AA0 6ES7 952-1AP00-0AA0 6ES7 952-1AS00-0AA0 6ES7 952-1AY00-0AA0	SIMATIC Manual Collection update service for 1 year Current "Manual Collection" DVD and the three subsequent updates	6ES7 998-8XC01-8YE2
FEPRAM memory card 64 KB 256 KB 1 MB 2 MB 4 MB 8 MB 16 MB 32 MB 64 MB	6ES7 952-0KF00-0AA0 6ES7 952-0KH00-0AA0 6ES7 952-1KK00-0AA0 6ES7 952-1KL00-0AA0 6ES7 952-1KM00-0AA0 6ES7 952-1KP00-0AA0 6ES7 952-1KS00-0AA0 6ES7 952-1KT00-0AA0 6ES7 952-1KY00-0AA0	RS 485 bus connector with 90° cable outlet Max. transfer rate 12 Mbit/s Without PG interface With PG interface	6ES7 972-0BA12-0XA0 6ES7 972-0BB12-0XA0
MPI cable for connection of SIMATIC S7 and PG via MPI; 5 m in length	6ES7 901-0BF00-0AA0	RS 485 bus connector with angled cable outlet Max. transfer rate 12 Mbit/s Without PG interface With PG interface	6ES7 972-0BA42-0XA0 6ES7 972-0BB42-0XA0
IF 964-DP interface module To connect an additional DP line; for CPU 414-3, CPU 414-3 PN/DP, CPU 416-3, CPU 416-3 PN/DP, CPU 417-4	6ES7 964-2AA04-0AB0	RS 485 bus connector with 90° cable outlet for FastConnect connection system Max. transfer rate 12 Mbit/s Without PG interface <ul style="list-style-type: none"> • 1 unit • 100 units With PG interface <ul style="list-style-type: none"> • 1 unit • 100 units 	6ES7 972-0BA52-0XA0 6ES7 972-0BA52-0XB0 6ES7 972-0BB52-0XA0 6ES7 972-0BB52-0XB0
Slot number plates 1 set (spare part)	6ES7 912-0AA00-0AA0	RS 485 bus connector with axial cable outlet For SIMATIC OP, for connection to PPI, MPI, PROFIBUS	6GK1 500-0EA02
		PROFIBUS FastConnect bus cable Standard type with special design for quick mounting, 2-core, shielded, sold by the meter, max. delivery unit 1000 m, minimum ordering quantity 20 m	6XV1 830-0EH10

SIMATIC S7-400

Central processing units

SIPLUS Standard CPUs
SIPLUS CPU 412

Overview



- The low-cost introduction to the mid performance range
- Can be used in small and medium-sized plants with requirements in the mid performance range

Note:

SIPLUS extreme products are based on Siemens Industry standard products. The contents listed here were taken from the respective standard products. SIPLUS extreme-specific information was added.

SIPLUS CPU 412	
Order No.	6AG1 412-2EK06-2AB0
Order No. based on	6ES7 412-2EK06-0AB0
Range of ambient temperature	-25 ... +70 °C
Conformal coating	Coating of the printed circuit boards and the electronic components
Technical data	The technical data of the standard product applies, except for the ambient conditions

Ambient conditions

Relative humidity	100%, condensation/frost permissible. No commissioning if condensation present.
Biologically active substances, compliance with EN 60721-3-3	Class 3B2 mold and fungal spores (excluding fauna). The supplied plug covers must remain in place over the unused interfaces during operation!
Chemically active substances, compliance with EN 60721-3-3	Class 3C4 incl. salt spray in accordance with EN60068-2-52 (degree of severity 3). The supplied plug covers must remain in place over the unused interfaces during operation!
Mechanically active substances, compliance with EN 60721-3-3	Class 3S4 incl. sand, dust. The supplied plug covers must remain in place over the unused interfaces during operation!
Air pressure (depending on the highest positive temperature range specified)	1080 ... 795 hPa (-1000 ... +2000 m) see ambient temperature range 795 ... 658 hPa (+2000 ... +3500 m) derating 10 K 658 ... 540 hPa (+3500 ... +5000 m) derating 20 K

For further technical documentation on SIPLUS, see:
www.siemens.com/siplus-extreme

Ordering data

Order No.

SIPLUS CPU 412-2 PN (extended temperature range and medial exposure) Main memory 1 MB, power supply 24 V DC, MPI/PROFIBUS DP master interface, PROFINET interface, slot for memory card, incl. slot number labels	6AG1 412-2EK06-2AB0
Memory Card RAM 2 MB 4 MB 8 MB 16 MB 64 MB	6AG1 952-1AL00-4AA0 6AG1 952-1AM00-7AA0 6AG1 952-1AP00-7AA0 6AG1 952-1AS00-7AA0 6AG1 952-1AY00-7AA0
RS 485 bus connector with 90° cable outlet (extended temperature range and medial exposure) Max. transfer rate 12 Mbit/s Without PG interface With PG interface	6AG1 972-0BA12-2XA0 6AG1 972-0BB12-2XA0
RS 485 bus connector with angled cable outlet (extended temperature range and medial exposure) Max. transfer rate 12 Mbit/s Without PG interface With PG interface	6AG1 972-0BA42-7XA0 6AG1 972-0BB42-7XA0
RS 485 bus connector with axial cable outlet For SIPLUS OP, for connection to PPI, MPI, PROFIBUS	6AG1 500-0EA02-2AA0
Further accessories	See SIMATIC CPU 412, page 6/7

SIMATIC S7-400

Central processing units

SIPLUS Standard CPUs
SIPLUS CPU 414

Overview



- CPUs for high demands in the mid-level performance range
- Applicable for plants with additional demands on programming scope and processing speed
- Integrated PROFINET functions in CPU 414-3 PN/DP

Note:

SIPLUS extreme products are based on Siemens Industry standard products. The contents listed here were taken from the respective standard products. SIPLUS extreme-specific information was added.

SIPLUS CPU 414	
Order No.	6AG1 414-3EM06-7AB0
Order No. based on	6ES7 414-3EM06-0AB0
Range of ambient temperature	-25 ... +70 °C
Conformal coating	Coating of the printed circuit boards and the electronic components
Technical data	The technical data of the standard product applies, except for the ambient conditions
Ambient conditions	
Relative humidity	100%, condensation/frost permissible. No commissioning if condensation present.
Biologically active substances, compliance with EN 60721-3-3	Class 3B2 mold and fungal spores (excluding fauna). The supplied plug covers must remain in place over the unused interfaces during operation!
Chemically active substances, compliance with EN 60721-3-3	Class 3C4 incl. salt spray in accordance with EN60068-2-52 (degree of severity 3). The supplied plug covers must remain in place over the unused interfaces during operation!
Mechanically active substances, compliance with EN 60721-3-3	Class 3S4 incl. sand, dust. The supplied plug covers must remain in place over the unused interfaces during operation!
Air pressure (depending on the highest positive temperature range specified)	1080 ... 795 hPa (-1000 ... +2000 m) see ambient temperature range 795 ... 658 hPa (+2000 ... +3500 m) derating 10 K 658 ... 540 hPa (+3500 ... +5000 m) derating 20 K

For further technical documentation on SIPLUS, see:
www.siemens.com/siplus-extreme

Ordering data

Order No.

SIPLUS 414-3 PN/DP (extended temperature range and medial exposure) Main memory 4 MB, power supply 24 V DC, MPI/PROFIBUS DP master interface, PROFINET interface, slot for memory card, module slot for 1 IF module, incl. slot number labels	6AG1 414-3EM06-7AB0
Memory Card RAM 2 MB 4 MB 8 MB 16 MB 64 MB	6AG1 952-1AL00-4AA0 6AG1 952-1AM00-7AA0 6AG1 952-1AP00-7AA0 6AG1 952-1AS00-7AA0 6AG1 952-1AY00-7AA0
IF 964-DP interface module For connecting an additional DP line; for SIPLUS CPU 414-3 PN/DP, CPU 416-3, CPU 416-3 PN/DP, CPU 417-4	6AG1964-2AA04-7AB0
RS 485 bus connector with 90° cable outlet (extended temperature range and medial exposure) max. transfer rate 12 Mbit/s without PG interface with PG interface	6AG1 972-0BA12-2XA0 6AG1 972-0BB12-2XA0
RS 485 bus connector with angled cable outlet (extended temperature range and medial exposure) max. transfer rate 12 Mbit/s without PG interface with PG interface	6AG1 972-0BA42-7XA0 6AG1 972-0BB42-7XA0
RS 485 bus connector with axial cable outlet (extended temperature range and medial exposure) For SIPLUS OP, for connection to PPI, MPI, PROFIBUS	6AG1 500-0EA02-2AA0
RS 485 repeater for PROFIBUS (extended temperature range and medial exposure) Transfer rate up to 12 Mbit/s; 24 V DC; IP20 enclosure	6AG1 972-0AA02-7XA0
SCALANCE X204-2 Industrial Ethernet Switch (medial exposure) Industrial Ethernet Switches with integral SNMP access, Web diagnostics, copper cable diagnostics and PROFINET diagnostics for configuring line, star and ring topologies; four 10/100 Mbit/s RJ45 ports and two FO ports	6AG1 204-2BB10-4AA3
IE FC RJ45 Plug 180 (extended temperature range and medial exposure) 180° cable outlet; 1 unit	6AG1 901-1BB10-7AA0
Further accessories	See SIMATIC CPU 414, page 6/11

SIMATIC S7-400

Central processing units

SIPLUS Standard CPUs
SIPLUS CPU 416

Overview



- High-performance CPUs in the high-end performance range
- Applicable for plants with high requirements in the high-end performance range
 - Integrated PROFINET functions in CPU 416-3 PN/DP

Note:

SIPLUS extreme products are based on Siemens Industry standard products. The contents listed here were taken from the respective standard products. SIPLUS extreme-specific information was added.

SIPLUS CPU 416-3		
Order number	6AG1 416-3XR05-4AB0	6AG1 416-3ES06-7AB0
Order No. based on	6ES7 416-3XR05-0AB0	6ES7 416-3ES06-0AB0
Range of ambient temperature	0 ... +60 °C	-25 ... +70 °C
Conformal coating	Coating of the printed circuit boards and the electronic components	
Technical data	The technical data of the standard product applies except for the ambient conditions	
Ambient conditions		
Relative humidity	100%, condensation/frost permissible. No commissioning if condensation present.	
Biologically active substances, compliance with EN 60721-3-3	Class 3B2 mold and fungal spores (excluding fauna). The supplied plug covers must remain in place over the unused interfaces during operation!	
Chemically active substances, compliance with EN 60721-3-3	Class 3C4 incl. salt spray in accordance with EN60068-2-52 (degree of severity 3). The supplied plug covers must remain in place over the unused interfaces during operation!	
Mechanically active substances, compliance with EN 60721-3-3	Class 3S4 incl. sand, dust. The supplied plug covers must remain in place over the unused interfaces during operation!	
Air pressure (depending on the highest positive temperature range specified)	1080 ... 795 hPa (-1000 ... +2000 m) see ambient temperature range 795 ... 658 hPa (+2000 ... +3500 m) derating 10 K 658 ... 540 hPa (+3500 ... +5000 m) derating 20 K	

For technical documentation on SIPLUS, see:
www.siemens.com/siplus-extreme

SIMATIC S7-400

Central processing units

SIPLUS Standard CPUs SIPLUS CPU 416

Ordering data	Order No.	Order No.
SIPLUS CPU 416-3 (medial exposure) Power supply 24 V DC, MPI/PROFIBUS DP master interface, PROFIBUS DP master interface, module slot for 1 IF module, slot for memory card, including mounting position labels 11.2 MB work memory	6AG1 416-3XR05-4AB0	RS 485 bus connector with angled cable outlet (extended temperature range and medial exposure) Max. transfer rate 12 Mbit/s Without PG interface With PG interface
SIPLUS CPU 416-3 PN/DP (extended temperature range and medial exposure) Power supply 24 V DC, MPI/PROFIBUS DP master interface, PROFINET interface, module slot for 1 IF module, slot for memory card, including mounting position labels 11.2 MB work memory	6AG1 416-3ES06-7AB0	RS 485 bus connector with axial cable outlet (extended temperature range and medial exposure) For SIPLUS OP, for connection to PPI, MPI, PROFIBUS
Memory Card RAM (medial exposure) 2 MB (extended temperature range and medial exposure) 4 MB 8 MB 16 MB 64 MB	6AG1 952-1AL00-4AA0 6AG1 952-1AM00-7AA0 6AG1 952-1AP00-7AA0 6AG1 952-1AS00-7AA0 6AG1 952-1AY00-7AA0	RS 485 repeater for PROFIBUS Transfer rate up to 12 Mbit/s; 24 V DC; IP20 enclosure
IF 964-DP interface module (extended temperature range and medial exposure) For connecting an additional DP line; for SIPLUS CPU 414-3 PN/DP, CPU 416-3, CPU 416-3 PN/DP, CPU 417-4	6AG1964-2AA04-7AB0	SCALANCE X204-2 Industrial Ethernet Switch Industrial Ethernet Switches with integral SNMP access, Web diagnostics, copper cable diagnostics and PROFINET diagnostics for configuring line, star and ring topologies; four 10/100 Mbit/s RJ45 ports and two FO ports
RS 485 bus connector with 90° cable outlet (extended temperature range and medial exposure) Max. transfer rate 12 Mbit/s Without PG interface With PG interface	6AG1 972-0BA12-2XA0 6AG1 972-0BB12-2XA0	IE FC RJ45 plug 180 (extended temperature range and medial exposure) 180° cable outlet; 1 unit
		Further accessories See SIMATIC CPU 416, page 6/16

SIMATIC S7-400

Central processing units

SIPLUS Standard CPUs
SIPLUS CPU 417

Overview



The most powerful SIMATIC S7-400 CPU

- Applicable for plants with maximum requirements in the high-end performance range
- With 2 plug-in slots for IF modules

Note:

SIPLUS extreme products are based on Siemens Industry standard products. The contents listed here were taken from the respective standard products. SIPLUS extreme specific information was added.

SIPLUS CPU 417-4	
Order number	6AG1 417-4XT05-4AB0
Order No. based on	6ES7 417-4XT05-0AB0
Ambient temperature range	0 ... +60 °C
Conformal coating	Coating of the printed circuit boards and the electronic components
Technical data	The technical data of the standard product applies except for the ambient conditions
Ambient conditions	
Relative humidity	100%, condensation/frost permissible. No commissioning if condensation present.
Biologically active substances, compliance with EN 60721-3-3	Class 3B2 mold and fungal spores (excluding fauna). The supplied plug covers must remain in place over the unused interfaces during operation!
Chemically active substances, compliance with EN 60721-3-3	Class 3C4 incl. salt spray in accordance with EN60068-2-52 (degree of severity 3). The supplied plug covers must remain in place over the unused interfaces during operation!
Mechanically active substances, compliance with EN 60721-3-3	Class 3S4 incl. sand, dust. The supplied plug covers must remain in place over the unused interfaces during operation!
Air pressure (depending on the highest positive temperature range specified)	1080 ... 795 hPa (-1000 ... +2000 m) see ambient temperature range 795 ... 658 hPa (+2000 ... +3500 m) derating 10 K 658 ... 540 hPa (+3500 ... +5000 m) derating 20 K

For technical documentation on SIPLUS, see:
www.siemens.com/siplus-extreme

Ordering data

Order No.

SIPLUS CPU 417-4 (medial exposure) Power supply 24 V DC, MPI/PROFIBUS DP master interface, PROFIBUS DP master interface, module slots for 2 additional IF modules, slot for memory card, including mounting position labels 30 MB work memory	6AG1 417-4XT05-4AB0
Accessories	
Memory card RAM (medial exposure) 2 MB (extended temperature range and medial exposure) 8 MB 16 MB 64 MB	6AG1 952-1AL00-4AA0 6AG1 952-1AP00-7AA0 6AG1 952-1AS00-7AA0 6AG1 952-1AY00-7AA0
EEPROM memory card (medial exposure) 32 MB	6AG1 952-1KT00-4AA0
RS 485 bus connector with 90° cable outlet (extended temperature range and medial exposure) Max. transfer rate 12 Mbit/s Without PG interface With PG interface	6AG1 972-0BA12-2XA0 6AG1 972-0BB12-2XA0
RS 485 bus connector with angled cable outlet (extended temperature range and medial exposure) Max. transfer rate 12 Mbit/s Without PG interface With PG interface	6AG1 972-0BA42-7XA0 6AG1 972-0BB42-7XA0
Further accessories	See SIMATIC CPU 417, page 6/20

SIMATIC S7-400

Central processing units

Fail-safe CPUs CPU 414F

Overview



- For constructing a fail-safe automation system for plants with increased safety requirements
- CPUs for high demands in the mid-level performance range
- Applicable for plants with additional demands on programming scope and processing speed
- Satisfies safety requirements up to SIL 3 acc. to IEC 61508 and Cat. 4 acc. to EN 954-1
- Standard and safety-related tasks can be performed with a single CPU
- Integrated PROFINET functions in CPU 414F-3 PN/DP
- Multi-processor mode is possible
- Safety-related communication with distributed I/O devices over PROFIBUS DP or PROFINET IO with PROFIsafe profile
- Fail-safe I/O modules can be connected in a distributed manner via the integrated interfaces (DP and PN with CPU 416F-3 PN/DP) and/or through communication modules (CP 443-5 Extended and CP 443-1 Adv.)
- Central and distributed use of standard modules for non-safety-oriented applications

6

Technical specifications

	6ES7 414-3FM06-0AB0 CPU 414F-3 PN/DP
General information	
Engineering with	
• Programming package	STEP7 V5.5 or higher/iMap V3.0 + iMap STEP7 Add-on V3.0 SP5 or higher
Supply voltage	
24 V DC	No; Power supply via system power supply
Power losses	
Power loss, typ.	6.5 W
Memory	
Work memory	
• integrated	4 Mbyte
• integrated (for program)	2 Mbyte
• integrated (for data)	2 Mbyte
Load memory	
• expandable FEPRM, max.	64 Mbyte
• integrated RAM, max.	512 kbyte
• expandable RAM, max.	64 Mbyte
CPU processing times	
for bit operations, typ.	45 ns
for word operations, typ.	45 ns
for fixed point arithmetic, typ.	45 ns
for floating point arithmetic, typ.	135 ns

	6ES7 414-3FM06-0AB0 CPU 414F-3 PN/DP
Counters, timers and their retentivity	
S7 counter	
• Number	2 048
IEC counter	
• present	Yes
S7 times	
• Number	2 048
IEC timer	
• present	Yes
Data areas and their retentivity	
Flag	
• Number, max.	8 kbyte; Size of bit memory address area
Address area	
I/O address area	
• Inputs	8 kbyte
• Outputs	8 kbyte
Process image	
• Inputs, adjustable	8 kbyte
• Outputs, adjustable	8 kbyte
Time of day	
Clock	
• Hardware clock (real-time clock)	Yes
Operating hours counter	
• Number	16

Technical specifications (continued)

6ES7 414-3FM06-0AB0 CPU 414F-3 PN/DP	
1st interface	
Type of interface	integrated
Physics	RS 485 / PROFIBUS + MPI
Functionality	
• MPI	Yes
• DP master	Yes
• DP slave	Yes
DP master	
• Number of DP slaves, max.	32
2nd interface	
Type of interface	PROFINET
Physics	Ethernet RJ45
Number of ports	2
Functionality	
• DP master	No
• DP slave	No
• PROFINET IO Controller	Yes
• PROFINET IO Device	Yes
• PROFINET CBA	Yes
PROFINET IO Controller	
• Max. number of connectable IO devices for RT	256
• Number of IO devices with IRT and the option "high flexibility"	256
• Number of IO Devices with IRT and the option "high performance", max.	64
3rd interface	
Type of interface	Pluggable interface module (IF)
Plug-in interface modules	IF 964-DP (MLFB: 6ES7964-2AA04-0AB0)
Physics	RS 485 / PROFIBUS
Functionality	
• MPI	No
• DP master	Yes
• DP slave	Yes
DP master	
• Number of DP slaves, max.	96
Isochronous mode	
Isochronous operation (application synchronized up to terminal)	Yes; Via PROFIBUS DP or PROFINET interface

6ES7 414-3FM06-0AB0 CPU 414F-3 PN/DP	
Communication functions	
PG/OP communication	Yes
Data record routing	Yes
Global data communication	
• supported	Yes
S7 basic communication	
• supported	Yes
S7 communication	
• supported	Yes
S5-compatible communication	
• supported	Yes; Via FC AG_SEND and AG_RECV, max. via 10 CP 443-1 or 443-5
Standard communication (FMS)	
• supported	Yes; Via CP and loadable FB
Open IE communication	
• TCP/IP	Yes; via integrated PROFINET interface and loadable FBs
- Number of connections, max.	62
• ISO-on-TCP (RFC1006)	Yes; Via integrated PROFINET interface or CP 443-1 Adv. and loadable FBs
- Number of connections, max.	62
• UDP	Yes; via integrated PROFINET interface and loadable FBs
- Number of connections, max.	62
Web server	
• supported	Yes
Number of connections	
• overall	64
Configuration	
programming	
• Programming language	
- LAD	Yes
- FBD	Yes
- STL	Yes
- SCL	Yes
- CFC	Yes
- GRAPH	Yes
- HiGraph®	Yes
Know-how protection	
• User program protection/password protection	Yes
• Block encryption	Yes; With S7 block Privacy
Dimensions	
Width	50 mm
Height	290 mm
Depth	219 mm
Required slots	2
Weight	
Weight, approx.	900 g

SIMATIC S7-400

Central processing units

Fail-safe CPUs CPU 414F

Ordering data	Order No.	Order No.
CPU 414F-3 PN/DP For setting up safety-related automation system; main memory 4 MB, power supply 24 V DC, MPI/PROFIBUS DP master interface, PROFINET interface, slot for memory card, module slot for 1 IF module, incl. slot number labels	6ES7 414-3FM06-0AB0	
Distributed Safety V5.4 programming tool Task: Configuration software for configuring fail-safe user programs for SIMATIC S7-300F, S7-400F, ET 200S Requirement: STEP 7 V5.3 SP3 and higher Floating license Floating license for 1 user, license key download without software or documentation ¹⁾ ; email address required for delivery	6ES7 833-1FC02-0YA5 6ES7 833-1FC02-0YH5	
Distributed Safety Upgrade From V5.x to V5.4; Floating license for 1 user	6ES7 833-1FC02-0YE5	
STEP 7 Safety Advanced V11 Task: Engineering tool for configuring fail-safe user programs for SIMATIC S7-300F, S7-400F, WinAC RTX F, ET 200S, ET 200M, ET 200iSP, ET 200pro, ET 200eco Requirement: STEP 7 Professional V11 SP1 Floating license for 1 user Floating license for 1 user, license key download without software or documentation ¹⁾ ; email address required for delivery	6ES7 833-1FA11-0YA5 6ES7 833-1FA11-0YH5	
STEP 7 Safety Advanced Upgrade Distributed Safety V5.4 SP5 and STEP 7 Safety Advanced V11 for parallel use; incl. software on CD; Combo License for 1 user Distributed Safety V5.4 SP5 and STEP 7 Safety Advanced V11 for parallel use; includes software on CD; combo license for 1 user, license key download without software or documentation ¹⁾ ; email address required for delivery	6ES7 833-1FA11-0YE5 6ES7 833-1FA11-0YK5	
Memory Card RAM 64 KB 256 KB 1 MB 2 MB 4 MB 8 MB 16 MB 64 MB	6ES7 952-0AF00-0AA0 6ES7 952-1AH00-0AA0 6ES7 952-1AK00-0AA0 6ES7 952-1AL00-0AA0 6ES7 952-1AM00-0AA0 6ES7 952-1AP00-0AA0 6ES7 952-1AS00-0AA0 6ES7 952-1AY00-0AA0	
		FEPRM memory card 64 KB 256 KB 1 MB 2 MB 4 MB 8 MB 16 MB 32 MB 64 MB
		MPI cable for connection of SIMATIC S7 and PG via MPI; 5 m in length
		IF 964-DP interface module For connecting an additional DP line
		Slot number plates 1 set (spare part)
		SIMATIC Manual Collection Electronic manuals on DVD, multilingual: LOGO!, SIMADYN, SIMATIC bus components, SIMATIC C7, SIMATIC distributed I/O, SIMATIC HMI, SIMATIC Sensors, SIMATIC NET, SIMATIC PC Based Automation, SIMATIC PCS 7, SIMATIC PG/PC, SIMATIC S7, SIMATIC Software, SIMATIC TDC
		SIMATIC Manual Collection update service for 1 year Current "Manual Collection" DVD and the three subsequent updates
		PROFIBUS bus components
		RS 485 bus connector with 90° cable outlet Max. transfer rate 12 Mbit/s Without PG interface With PG interface
		RS 485 bus connector with angled cable outlet Max. transfer rate 12 Mbit/s Without PG interface With PG interface
		RS 485 bus connector with 90° cable outlet for FastConnect connection system Max. transfer rate 12 Mbit/s Without PG interface • 1 unit • 100 units With PG interface • 1 unit • 100 units
		RS 485 bus connector with axial cable outlet For SIMATIC OP, for connection to PPI, MPI, PROFIBUS
		6ES7952-0KF00-0AA0 6ES7952-0KH00-0AA0 6ES7 952-1KK00-0AA0 6ES7 952-1KL00-0AA0 6ES7 952-1KM00-0AA0 6ES7 952-1KP00-0AA0 6ES7 952-1KS00-0AA0 6ES7 952-1KT00-0AA0 6ES7 952-1KY00-0AA0 6ES7 901-0BF00-0AA0 6ES7 964-2AA04-0AB0 6ES7 912-0AA00-0AA0 6ES7 998-8XC01-8YE0 6ES7 998-8XC01-8YE2 6ES7 972-0BA12-0XA0 6ES7 972-0BB12-0XA0 6ES7 972-0BA42-0XA0 6ES7 972-0BB42-0XA0 6ES7 972-0BA52-0XA0 6ES7 972-0BA52-0XB0 6ES7 972-0BB52-0XA0 6ES7 972-0BB52-0XB0 6GK1 500-0EA02

¹⁾ For up-to-date information and download availability, see: www.siemens.com/tia-online-software-delivery

SIMATIC S7-400

Central processing units

Fail-safe CPUs
CPU 414F

Ordering data	Order No.	Order No.
PROFIBUS FastConnect bus cable Standard type with special design for quick mounting, 2-core, shielded, sold by the meter, max. delivery unit 1000 m, minimum ordering quantity 20 m	6XV1 830-0EH10	6GK5 204-2BB10-2AA3
RS 485 repeater for PROFIBUS Transmission rate up to 12 Mbit/s; 24 V DC; IP20 enclosure	6ES7 972-0AA02-0XA0	
PROFINET bus components IE FC TP standard cable GP 2x2 4-core, shielded TP installation cable for connection to IE FC Outlet RJ45/IE FC RJ45 Plug; PROFINET-compatible; with UL approval; Sold by the meter	6XV1 840-2AH10	SCALANCE X204-2 Industrial Ethernet Switch Industrial Ethernet Switches with integral SNMP access, Web diagnostics, copper cable diagnostics and PROFINET diagnostics for configuring line, star and ring topologies; four 10/100 Mbit/s RJ45 ports and two FO ports IE FC RJ45 plugs RJ45 plug connector for Industrial Ethernet with a rugged metal enclosure and integrated insulation displacement contacts for connecting Industrial Ethernet FC installation cables IE FC RJ45 plug 180 180° cable outlet 1 unit 10 units 50 units
FO Standard Cable GP (50/125) Standard cable, splittable, UL approval, sold by the meter	6XV1 873-2A	
		6GK1 901-1BB10-2AA0 6GK1 901-1BB10-2AB0 6GK1 901-1BB10-2AE0
		PROFIBUS/PROFINET bus components For establishing MPI/PROFIBUS/PROFINET communication See IK PI, CA 01 catalogs

SIMATIC S7-400

Central processing units

Fail-safe CPUs CPU 416F

Overview



- For constructing a fail-safe automation system for plants with increased safety requirements
- High-performance CPU in the top-end performance range
- Satisfies safety requirements up to SIL 3 acc. to IEC 61508 and Cat. 4 acc. to EN 954-1
- Standard and safety-related tasks can be performed with a single CPU
- Multi-processor mode is possible
- Safety-related communication with distributed I/O devices over PROFIBUS DP with the *PROFIsafe* profile
- Fail-safe I/O modules can be connected decentralized over the integrated interfaces (DP and PN with CPU416F-3 PN/DP) and/or through communication modules (CP443-5 Ext. and CP443-1 Adv.)
- Standard modules for non-safety-related applications can be operated centrally and decentralized

Technical specifications

	6ES7 416-2FN05-0AB0 CPU 416F-2	6ES7 416-3FS06-0AB0 CPU416F-3 PN/DP
General information		
Engineering with		
• Programming package	STEP 7 V5.3 SP2 or higher with hardware update, Distributed Safety V5.2 SP2 or higher	STEP7 V5.5 or higher/iMap V3.0 + iMap STEP7 Add-on V3.0 SP5 or higher
Supply voltage		
24 V DC	No; Power supply via system power supply	No; Power supply via system power supply
Power losses		
Power loss, typ.	4.5 W	6.5 W
Memory		
Work memory		
• integrated	5.6 Mbyte	16 Mbyte
• integrated (for program)	2.8 Mbyte	8 Mbyte
• integrated (for data)	2.8 Mbyte	8 Mbyte
Load memory		
• expandable FEPRAM, max.	64 Mbyte	64 Mbyte
• integrated RAM, max.	1 Mbyte	1 Mbyte
• expandable RAM, max.	64 Mbyte	64 Mbyte
CPU processing times		
for bit operations, typ.	30 ns	30 ns
for word operations, typ.	30 ns	30 ns
for fixed point arithmetic, typ.	30 ns	30 ns
for floating point arithmetic, typ.	90 ns	90 ns
Counters, timers and their retentivity		
S7 counter		
• Number	2 048	2 048
IEC counter		
• present	Yes	Yes
S7 times		
• Number	2 048	2 048
IEC timer		
• present	Yes	Yes

Technical specifications (continued)

	6ES7 416-2FN05-0AB0 CPU 416F-2	6ES7 416-3FS06-0AB0 CPU416F-3 PN/DP
Data areas and their retentivity		
Flag		
• Number, max.	16 kbyte; Size of bit memory address area	16 kbyte; Size of bit memory address area
Address area		
I/O address area		
• Inputs	16 kbyte	16 kbyte
• Outputs	16 kbyte	16 kbyte
Process image		
• Inputs, adjustable	16 kbyte	16 kbyte
• Outputs, adjustable	16 kbyte	16 kbyte
Time of day		
Clock		
• Hardware clock (real-time clock)	Yes	Yes
Operating hours counter		
• Number	16	16
1st interface		
Type of interface	integrated	integrated
Physics	RS 485 / PROFIBUS + MPI	RS 485 / PROFIBUS + MPI
Functionality		
• MPI	Yes	Yes
• DP master	Yes	Yes
• DP slave	Yes	Yes
DP master		
• Number of DP slaves, max.	32	32
2nd interface		
Type of interface	integrated	PROFINET
Physics	RS 485 / PROFIBUS	Ethernet RJ45
Number of ports		2
Functionality		
• DP master	Yes	No
• DP slave	Yes	No
• PROFINET IO Controller		Yes
• PROFINET IO Device		Yes
• PROFINET CBA		Yes
DP master		
• Number of DP slaves, max.	125	
PROFINET IO Controller		
• Max. number of connectable IO devices for RT		256
• Number of IO devices with IRT and the option "high flexibility"		256
• Number of IO Devices with IRT and the option "high performance", max.		64
3rd interface		
Type of interface		Pluggable interface module (IF)
Plug-in interface modules		IF 964-DP (MLFB: 6ES7964-2AA04-0AB0)
Physics		RS 485 / PROFIBUS
Functionality		
• MPI		No
• DP master		Yes
• DP slave		Yes
DP master		
• Number of DP slaves, max.		125

SIMATIC S7-400

Central processing units

Fail-safe CPUs CPU 416F

Technical specifications (continued)

	6ES7 416-2FN05-0AB0 CPU 416F-2	6ES7 416-3FS06-0AB0 CPU416F-3 PN/DP
Isochronous mode		
Isochronous operation (application synchronized up to terminal)	Yes; For PROFIBUS only	Yes; Via PROFIBUS DP or PROFINET interface
Communication functions		
PG/OP communication	Yes	Yes
Data record routing	Yes	Yes
Global data communication		
• supported	Yes	Yes
S7 basic communication		
• supported	Yes	Yes
S7 communication		
• supported	Yes	Yes
S5-compatible communication		
• supported	Yes; Via FC AG_SEND and AG_RECV, max. via 10 CP 443-1 or 443-5	Yes; Via FC AG_SEND and AG_RECV, max. via 10 CP 443-1 or 443-5
Standard communication (FMS)		
• supported	Yes; Via CP and loadable FB	Yes; Via CP and loadable FB
Open IE communication		
• TCP/IP		Yes; via integrated PROFINET interface and loadable FBs 94
- Number of connections, max.		Yes; Via integrated PROFINET interface or CP 443-1 and loadable FBs 94
• ISO-on-TCP (RFC1006)	Via CP 443-1 and loadable FB	Yes; via integrated PROFINET interface and loadable FBs 94
- Number of connections, max.		
• UDP		
- Number of connections, max.		
Web server		
• supported	No	Yes
Number of connections		
• overall	64	96
Configuration programming		
• Programming language		
- LAD	Yes	Yes
- FBD	Yes	Yes
- STL	Yes	Yes
- SCL	Yes	Yes
- CFC	Yes	Yes
- GRAPH	Yes	Yes
- HiGraph®	Yes	Yes
Know-how protection		
• User program protection/password protection	Yes	Yes
• Block encryption		Yes; With S7 block Privacy
Dimensions		
Width	25 mm	50 mm
Height	290 mm	290 mm
Depth	219 mm	219 mm
Required slots	1	2
Weight		
Weight, approx.	0.7 kg	900 g

Ordering data	Order No.	Order No.
CPU 416F-2 For configuring safety-related automation systems; 5.6 MB RAM, 24 V DC power supply, MPI/PROFIBUS DP master interface, PROFIBUS DP master interface, slot for memory card, incl. slot number labels	6ES7 416-2FN05-0AB0	Memory card RAM 64 KB 6ES7 952-0AF00-0AA0 256 KB 6ES7 952-1AH00-0AA0 1 MB 6ES7 952-1AK00-0AA0 2 MB 6ES7 952-1AL00-0AA0 4 MB 6ES7 952-1AM00-0AA0 8 MB 6ES7 952-1AP00-0AA0 16 MB 6ES7 952-1AS00-0AA0 64 MB 6ES7 952-1AY00-0AA0
CPU 416F-3 PN/DP For configuring safety-related automation systems; main memory 16 MB, 24 V DC power supply, MPI/PROFIBUS DP master interface, PROFINET interface, PROFIBUS DP master interface, receptacle for 1 IF submodule, slot for memory card, incl. slot number labels	6ES7 416-3FS06-0AB0	FEPR0M memory card 64 KB 6ES7952-0KF00-0AA0 256 KB 6ES7952-0KH00-0AA0 1 MB 6ES7 952-1KK00-0AA0 2 MB 6ES7 952-1KL00-0AA0 4 MB 6ES7 952-1KM00-0AA0 8 MB 6ES7 952-1KP00-0AA0 16 MB 6ES7 952-1KS00-0AA0 32 MB 6ES7 952-1KT00-0AA0 64 MB 6ES7 952-1KY00-0AA0
S7 Distributed Safety V5.4 programming tool Task: Configuration software for configuring fail-safe user programs for SIMATIC S7-300F, S7-400F, ET 200S Requirement: STEP 7 V5.3 SP3 and higher Floating license	6ES7 833-1FC02-0YA5 6ES7 833-1FC02-0YH5	MPI cable for connection of SIMATIC S7 and PG via MPI; 5 m in length 6ES7 901-0BF00-0AA0
S7 Distributed Safety upgrade Floating license for 1 user, license key download without software or documentation ¹⁾ ; email address required for delivery	6ES7 833-1FC02-0YE5	IF 964-DP interface module For connecting an additional DP line 6ES7 964-2AA04-0AB0
STEP 7 Safety Advanced V11 Task: Engineering tool for configuring fail-safe user programs for SIMATIC S7-300F, S7-400F, WinAC RTX F, ET 200S, ET 200M, ET 200iSP, ET 200pro, ET 200eco Requirement: STEP 7 Professional V11 SP1 Floating license for 1 user	6ES7 833-1FA11-0YA5 6ES7 833-1FA11-0YH5	Slot number plates 1 set (spare part) 6ES7 912-0AA00-0AA0
STEP 7 Safety Advanced Upgrade Distributed Safety V5.4 SP5 and STEP 7 Safety Advanced V11 for parallel use; incl. software on CD; Combo License for 1 user	6ES7 833-1FA11-0YE5	SIMATIC Manual Collection Electronic manuals on DVD, multilingual: LOGO!, SIMADYN, SIMATIC bus components, SIMATIC C7, SIMATIC distributed I/O, SIMATIC HMI, SIMATIC Sensors, SIMATIC NET, SIMATIC PC Based Automation, SIMATIC PCS 7, SIMATIC PG/PC, SIMATIC S7, SIMATIC Software, SIMATIC TDC 6ES7 998-8XC01-8YE0
Distributed Safety V5.4 SP5 and STEP 7 Safety Advanced V11 for parallel use; includes software on CD; combo license for 1 user, license key download without software or documentation ¹⁾ ; email address required for delivery	6ES7 833-1FA11-0YK5	SIMATIC Manual Collection update service for 1 year Current "Manual Collection" DVD and the three subsequent updates 6ES7 998-8XC01-8YE2

¹⁾ For up-to-date information and download availability, see: www.siemens.com/tia-online-software-delivery

SIMATIC S7-400

Central processing units

Fail-safe CPUs
CPU 416F

Ordering data

Order No.

PROFIBUS bus components

RS 485 bus connector with 90° cable outlet

Max. transfer rate 12 Mbit/s

Without PG interface

6ES7 972-0BA12-0XA0

With PG interface

6ES7 972-0BB12-0XA0

RS 485 bus connector with angled cable outlet

Max. transfer rate 12 Mbit/s

Without PG interface

6ES7 972-0BA42-0XA0

With PG interface

6ES7 972-0BB42-0XA0

RS 485 bus connector with 90° cable outlet for FastConnect system

Max. transfer rate 12 Mbit/s

Without PG interface

- 1 unit
- 100 units

6ES7 972-0BA52-0XA0

6ES7 972-0BA52-0XB0

With PG interface

- 1 unit
- 100 units

6ES7 972-0BB52-0XA0

6ES7 972-0BB52-0XB0

RS 485 bus connector with axial cable outlet

For SIMATIC OP, for connection to PPI, MPI, PROFIBUS

6GK1 500-0EA02

PROFIBUS FastConnect bus cable

Standard type with special design for quick mounting, 2-core, shielded, sold by the meter, max. delivery unit 1000 m, minimum ordering quantity 20 m

6XV1 830-0EH10

RS 485 repeater for PROFIBUS

Transmission rate up to 12 Mbit/s; 24 V DC; IP20 enclosure

6ES7 972-0AA02-0XA0

Order No.

PROFINET bus components

IE FC TP standard cable GP 2x2

4-core, shielded TP installation cable for connection to IE FC Outlet RJ45/ IE FC RJ45 Plug; PROFINET-compatible; with UL approval; Sold by the meter

6XV1 840-2AH10

FO Standard Cable GP (50/125)

Standard cable, splittable, UL approval, sold by the meter

6XV1 873-2A

SCALANCE X204-2 Industrial Ethernet Switch

Industrial Ethernet Switches with integral SNMP access, web diagnostics, copper cable diagnostics and PROFINET diagnostics for configuring line, star and ring topologies; four 10/100 Mbit/s RJ45 ports and two FO ports

6GK5 204-2BB10-2AA3

IE FC RJ45 plugs

RJ45 plug connector for Industrial Ethernet with a rugged metal enclosure and integrated insulation displacement contacts for connecting Industrial Ethernet FC installation cables

IE FC RJ45 plug 180

180° cable outlet

1 unit

6GK1 901-1BB10-2AA0

10 units

6GK1 901-1BB10-2AB0

50 units

6GK1 901-1BB10-2AE0

PROFIBUS/PROFINET bus components

For establishing MPI/PROFIBUS/PROFINET communication

See IK PI, CA 01 catalogs

SIMATIC S7-400

Central processing units

High-availability CPUs
CPU 412H, CPU 414H, CPU 416H, CPU 417H

Overview CPU 412H



- CPU for SIMATIC S7-400H and S7-400F/FH
- Can be used in S7-400H high-availability systems
- Can be used with F runtime license as F-capable CPU in S7-400F/FH safety-related systems
- With integrated PROFIBUS DP master and combined MPI/PROFIBUS DP master interface
- With integrated PROFINET interface (2-port switch)
- Features 2 slots for sync modules

Overview CPU 414H



- CPU for SIMATIC S7-400H and S7-400F/FH
- Can be used in S7-400H high-availability systems
- Can be used with F runtime license as F-capable CPU in S7-400F/FH safety-related systems
- With integrated PROFIBUS DP master and combined MPI/PROFIBUS DP master interface
- With integrated PROFINET interface (2-port switch)
- Features 2 slots for sync modules

Overview CPU 416H

- CPU for SIMATIC S7-400H and S7-400F/FH
- Can be used in S7-400H high-availability systems
- Can be used with F runtime license as F-capable CPU in S7-400F/FH safety-related systems
- With integrated PROFIBUS DP master and combined MPI/PROFIBUS DP master interface
- With integrated PROFINET interface (2-port switch)
- Features 2 slots for sync modules

Overview CPU 417H



- CPU for SIMATIC S7-400H and S7-400F/FH
- Can be used in S7-400H high-availability systems
- Can be used with F runtime license as F-capable CPU in S7-400F/FH safety-related systems
- With integrated PROFIBUS DP master interface and combined MPI/PROFIBUS DP master interface
- With integrated PROFINET interface (2-port switch)
- Features 2 slots for sync modules

SIMATIC S7-400

Central processing units

High-availability CPUs
CPU 412H, CPU 414H, CPU 416H, CPU 417H

Technical specifications

	6ES7 412-5HK06-0AB0 CPU 412-5H PN/DP	6ES7 414-5HM06-0AB0 CPU 414-5H PN/DP	6ES7 416-5HS06-0AB0 CPU 416-5H PN/DP	6ES7 417-5HT06-0AB0 CPU 417-5H PN/DP
General information				
Engineering with • Programming package	As of STEP 7 V5.5 SP2 with HF1	As of STEP 7 V5.5 SP2 with HF1	As of STEP 7 V5.5 SP2 with HF1	As of STEP 7 V5.5 SP2 with HF1
Supply voltage				
24 V DC	No; Power supply via system power supply	No; Power supply via system power supply	No; Power supply via system power supply	No; Power supply via system power supply
Power losses				
Power loss, typ.	7.5 W	7.5 W	7.5 W	7.5 W
Memory				
Work memory • integrated	1 Mbyte	4 Mbyte	16 Mbyte	32 Mbyte
• integrated (for program)	512 kbyte	2 Mbyte	6 Mbyte	16 Mbyte
• integrated (for data)	512 kbyte	2 Mbyte	10 Mbyte	16 Mbyte
Load memory • expandable FEPRAM, max.	64 Mbyte	64 Mbyte	64 Mbyte	64 Mbyte
• integrated RAM, max.	512 kbyte	512 kbyte	1 Mbyte	1 Mbyte
• expandable RAM, max.	64 Mbyte	64 Mbyte	64 Mbyte	64 Mbyte
CPU processing times				
for bit operations, typ.	31.25 ns	18.75 ns	12.5 ns	7.5 ns
for word operations, typ.	31.25 ns	18.75 ns	12.5 ns	7.5 ns
for fixed point arithmetic, typ.	31.25 ns	18.75 ns	12.5 ns	7.5 ns
for floating point arithmetic, typ.	62.5 ns	37.5 ns	25 ns	15 ns
Counters, timers and their retentivity				
S7 counter • Number	2 048	2 048	2 048	2 048
IEC counter • present	Yes	Yes	Yes	Yes
S7 timer • Number	2 048	2 048	2 048	2 048
IEC timer • present	Yes	Yes	Yes	Yes
Data areas and their retentivity				
Flag • Number, max.	8 192 byte	8 192 byte	16 384 byte	16 384 byte
Address area				
I/O address area • Inputs	8 kbyte	8 kbyte	16 kbyte	16 kbyte
• Outputs	8 kbyte	8 kbyte	16 kbyte	16 kbyte
Process image • Inputs, adjustable	8 kbyte	8 kbyte	16 kbyte	16 kbyte
• Outputs, adjustable	8 kbyte	8 kbyte	16 kbyte	16 kbyte
Time of day				
Clock • Hardware clock (real-time clock)	Yes	Yes	Yes	Yes
Operating hours counter • Number	16	16	16	16

SIMATIC S7-400

Central processing units

High-availability CPUs
CPU 412H, CPU 414H, CPU 416H, CPU 417H

Technical specifications (continued)

	6ES7 412-5HK06-0AB0 CPU 412-5H PN/DP	6ES7 414-5HM06-0AB0 CPU 414-5H PN/DP	6ES7 416-5HS06-0AB0 CPU 416-5H PN/DP	6ES7 417-5HT06-0AB0 CPU 417-5H PN/DP
1st interface				
Type of interface	integrated	integrated	integrated	integrated
Physics	RS 485 / PROFIBUS + MPI	RS 485 / PROFIBUS + MPI	RS 485 / PROFIBUS + MPI	RS 485 / PROFIBUS + MPI
Functionality				
• MPI	Yes	Yes	Yes	Yes
• DP master	Yes	Yes	Yes	Yes
• DP slave	No	No	No	No
DP master				
• Number of DP slaves, max.	32	32	32	32
2nd interface				
Type of interface	PROFINET	PROFINET	PROFINET	PROFINET
Physics	Ethernet RJ45	Ethernet RJ45	Ethernet RJ45	Ethernet RJ45
Number of ports	2	2	2	2
Functionality				
• DP master	No	No	No	No
• DP slave	No	No	No	No
• PROFINET IO Controller	Yes	Yes	Yes	Yes
• PROFINET IO Device	No	No	No	No
• PROFINET CBA	No	No	No	No
PROFINET IO Controller				
• Max. number of connectable IO devices for RT	256	256	256	256
3rd interface				
Type of interface	integrated	integrated	integrated	integrated
Physics	RS 485 / PROFIBUS	RS 485 / PROFIBUS	RS 485 / PROFIBUS	RS 485 / PROFIBUS
Functionality				
• DP master	Yes	Yes	Yes	Yes
• DP slave	No	No	No	No
DP master				
• Number of DP slaves, max.	64	96	125	125
4th interface				
Type of interface	Pluggable synchronization submodule (FO)	Pluggable synchronization submodule (FO)	Pluggable synchronization submodule (FO)	Pluggable synchronization submodule (FO)
Plug-in interface modules	Synchronization modules 6ES7960-1AA06-0XA0 or 6ES7960-1AB06-0XA0	Synchronization modules 6ES7960-1AA06-0XA0 or 6ES7960-1AB06-0XA0	Synchronization modules 6ES7960-1AA06-0XA0 or 6ES7960-1AB06-0XA0	Synchronization modules 6ES7960-1AA06-0XA0 or 6ES7960-1AB06-0XA0
5th Interface				
Type of interface	Pluggable synchronization submodule (FO)	Pluggable synchronization submodule (FO)	Pluggable synchronization submodule (FO)	Pluggable synchronization submodule (FO)
Plug-in interface modules	Synchronization modules 6ES7960-1AA06-0XA0 or 6ES7960-1AB06-0XA0	Synchronization modules 6ES7960-1AA06-0XA0 or 6ES7960-1AB06-0XA0	Synchronization modules 6ES7960-1AA06-0XA0 or 6ES7960-1AB06-0XA0	Synchronization modules 6ES7960-1AA06-0XA0 or 6ES7960-1AB06-0XA0
Isochronous mode				
Isochronous operation (application synchronized up to terminal)	No	No	No	No

SIMATIC S7-400

Central processing units

High-availability CPUs
CPU 412H, CPU 414H, CPU 416H, CPU 417H

Technical specifications (continued)

	6ES7 412-5HK06-0AB0 CPU 412-5H PN/DP	6ES7 414-5HM06-0AB0 CPU 414-5H PN/DP	6ES7 416-5HS06-0AB0 CPU 416-5H PN/DP	6ES7 417-5HT06-0AB0 CPU 417-5H PN/DP
Communication functions				
PG/OP communication	Yes	Yes	Yes	Yes
Data record routing	Yes	Yes	Yes	Yes
S7 routing	Yes	Yes	Yes	Yes
Global data communication • supported	No	No	No	No
S7 basic communication • supported	No	No	No	No
S7 communication • supported	Yes	Yes	Yes	Yes
S5-compatible communication • supported	Yes; (via CP max. 10 and FC AG_SEND and FC AG_RECV)	Yes; (via CP max. 10 and FC AG_SEND and FC AG_RECV)	Yes; (via CP max. 10 and FC AG_SEND and FC AG_RECV)	Yes; (via CP max. 10 and FC AG_SEND and FC AG_RECV)
Standard communication (FMS) • supported	Yes; Via CP and loadable FB	Yes; Via CP and loadable FB	Yes; Via CP and loadable FB	Yes; Via CP and loadable FB
Open IE communication • TCP/IP	Yes; via integrated PROFINET interface and loadable FBs	Yes; via integrated PROFINET interface and loadable FBs	Yes; via integrated PROFINET interface and loadable FBs	Yes; via integrated PROFINET interface and loadable FBs
- Number of connections, max.	46	62	94	118
• ISO-on-TCP (RFC1006)	Yes; Via integrated PROFINET interface or CP 443-1 and loadable FBs	Yes; Via integrated PROFINET interface or CP 443-1 and loadable FBs	Yes; Via integrated PROFINET interface or CP 443-1 and loadable FBs	Yes; Via integrated PROFINET interface or CP 443-1 and loadable FBs
- Number of connections, max.	46	62	94	118
• UDP	Yes; via integrated PROFINET interface and loadable FBs	Yes; via integrated PROFINET interface and loadable FBs	Yes; via integrated PROFINET interface and loadable FBs	Yes; via integrated PROFINET interface and loadable FBs
- Number of connections, max.	46	62	94	118
Web server • supported	No	No	No	No
Number of connections • overall	48	64	96	120
Configuration				
programming				
• Programming language				
- LAD	Yes	Yes	Yes	Yes
- FBD	Yes	Yes	Yes	Yes
- STL	Yes	Yes	Yes	Yes
- SCL	Yes	Yes	Yes	Yes
- CFC	Yes	Yes	Yes	Yes
- GRAPH	Yes	Yes	Yes	Yes
- HiGraph®	Yes	Yes	Yes	Yes
Know-how protection				
• User program protection/password protection	Yes	Yes	Yes	Yes
• Block encryption	Yes; With S7 block Privacy	Yes; With S7 block Privacy	Yes; With S7 block Privacy	Yes; With S7 block Privacy
Dimensions				
Width	50 mm	50 mm	50 mm	50 mm
Height	290 mm	290 mm	290 mm	290 mm
Depth	219 mm	219 mm	219 mm	219 mm
Required slots	2	2	2	2
Weight				
Weight, approx.	995 g	995 g	995 g	995 g

SIMATIC S7-400

Central processing units

High-availability CPUs
CPU 412H, CPU 414H, CPU 416H, CPU 417H

Ordering data	Order No.	Order No.
CPU 412-5H For S7-400H and S7-400F/FH; 1 MB RAM, 1 combined MPI/ PROFIBUS DP master interface, 1 PROFIBUS DP interface, 2 PROFINET interfaces (switches), 2 slots for sync modules, slot for memory card, incl. slot number labels	6ES7 412-5HK06-0AB0	
CPU 412-5H system bundle Not assembled, consisting of: UR2-H rack, 2 x PS 405/407 power supply units, 2 x CPU 412-5H, 4 x Sync modules (for max. 10 m), 2 x fiber optic cables for sync mod- ules (1 m), 4 x backup batteries; additional two memory cards required (to be ordered separately)		
412-5H system bundle, 120/230 V AC, 10 A	6ES7 400-0HR01-4AB0	
412-5H system bundle, 24/48/60 V DC, 10 A	6ES7 400-0HR51-4AB0	
CPU 414-5H For S7-400H and S7-400F/FH; 4 MB RAM, 1 combined MPI/ PROFIBUS DP master interface, 1 PROFIBUS DP interface, 2 PROFINET interfaces (switches), 2 slots for sync modules, slot for memory card, incl. slot number labels	6ES7 414-5HM06-0AB0	
CPU 414-5H system bundle Not assembled, consisting of: UR2-H rack, 2 x PS 405/407 power supply units, 2 x CPU 414-5H, 4 x Sync modules (for max. 10 m), 2 x fiber optic cables for sync mod- ules (1 m), 4 x backup batteries; two additional memory cards required (to be ordered separately)		
414-5H system bundle, 120/230 V AC, 10 A	6ES7 400-0HR02-4AB0	
414-5H system bundle, 24/48/60 V DC, 10 A	6ES7 400-0HR52-4AB0	
CPU 416-5H For S7-400H and S7-400F/FH; 16 MB RAM, 1 combined MPI/ PROFIBUS DP master interface, 1 PROFIBUS DP interface, 2 PROFINET interfaces (switches), 2 slots for sync modules, slot for memory card, incl. slot number labels	6ES7 416-5HS06-0AB0	
CPU 416-5H system bundle Not assembled, consisting of: UR2-H rack, 2 x PS 405/407 power supply units, 2 x CPU 416-5H, 4 x Sync modules (for max. 10 m), 2 x fiber optic cables for sync mod- ules (1 m), 4 x backup batteries; two additional memory cards required (to be ordered separately)		
416-5H system bundle, 120/230 V AC, 10 A	6ES7 400-0HR03-4AB0	
416-5H system bundle, 24/48/60 V DC, 10 A	6ES7 400-0HR53-4AB0	
CPU 417-5H For S7-400H and S7-400F/FH; 32 MB RAM, 1 combined MPI/PROFIBUS DP master inter- face, 1 PROFIBUS DP interface, 2 PROFINET interfaces (switches), 2 slots for sync modules, slot for memory card, incl. slot number labels	6ES7 417-5HT06-0AB0	
CPU 417-5H system bundle Not assembled, consisting of: UR2-H rack, 2 x PS 405/407 power supply units, 2 x CPU 417-5H, 4 x Sync modules (for max. 10 m), 2 x fiber optic cables for sync mod- ules (1 m), 4 x backup batteries; two additional memory cards required (to be ordered separately)		
417-5H system bundle, 120/230 V AC, 10 A	6ES7 400-0HR04-4AB0	
417-5H system bundle, 24/48/60 V DC, 10 A	6ES7 400-0HR54-4AB0	
Memory card RAM		
1 MB	6ES7 952-1AK00-0AA0	
2 MB	6ES7 952-1AL00-0AA0	
4 MB	6ES7 952-1AM00-0AA0	
8 MB	6ES7 952-1AP00-0AA0	
16 MB	6ES7 952-1AS00-0AA0	
64 MB	6ES7 952-1AY00-0AA0	
FEPROM memory card		
1 MB	6ES7 952-1KK00-0AA0	
2 MB	6ES7 952-1KL00-0AA0	
4 MB	6ES7 952-1KM00-0AA0	
8 MB	6ES7 952-1KP00-0AA0	
16 MB	6ES7 952-1KS00-0AA0	
32 MB	6ES7 952-1KT00-0AA0	
64 MB	6ES7 952-1KY00-0AA0	

SIMATIC S7-400

Central processing units

High-availability CPUs
CPU 412H, CPU 414H, CPU 416H, CPU 417H

Ordering data	Order No.	Order No.
MPI cable for connection of SIMATIC S7 and PG via MPI; 5 m in length	6ES7 901-0BF00-0AA0	SIMATIC Manual Collection update service for 1 year Current "Manual Collection" DVD and the three subsequent updates
Slot number plates 1 set (spare part)	6ES7 912-0AA00-0AA0	RS 485 bus connector with 90° cable outlet Max. transfer rate 12 Mbit/s Without PG interface With PG interface
S7 F Systems RT License For processing safety-related user programs, for one S7 400H-based system each with CPU 412-5H, CPU 414-5H, CPU 416-5H or CPU 417-5H	6ES7 833-1CC00-6YX0	RS 485 bus connector with angled cable outlet Max. transfer rate 12 Mbit/s Without PG interface With PG interface Max. transfer rate 1.5 Mbit/s Without PG interface
S7 F Systems V6.1 Programming and configuring environment for creating and operating safety-related STEP 7 programs for an S7 400H-based target system, floating license for 1 user, runs under Windows XP Prof SP2, Windows XP Prof SP2/SP3, Windows Server 2003 SP2 2 languages (English, German) Type of delivery: License certificate as well as software and electronic documentation on CD	6ES7 833-1CC02-0YA5	Bus connector RS 485 with 90° cable outlet for FastConnect connection technology Max. transfer rate 12 Mbit/s Without PG interface • 1 unit • 100 units With PG interface • 1 unit • 100 units
S7 F systems upgrade from V5.x/V6.0 to V6.1 2 languages (English, German), floating license for 1 user Type of delivery: License certificate as well as software and electronic documentation on CD	6ES7 833-1CC02-0YE5	RS 485 bus connector with axial cable outlet For SIMATIC OP, for connection to PPI, MPI, PROFIBUS
SIMATIC Manual Collection Electronic manuals on DVD, multilingual: LOGO!, SIMADYN, SIMATIC bus components, SIMATIC C7, SIMATIC distributed I/O, SIMATIC HMI, SIMATIC Sensors, SIMATIC NET, SIMATIC PC Based Automation, SIMATIC PCS 7, SIMATIC PG/PC, SIMATIC S7, SIMATIC Software, SIMATIC TDC	6ES7 998-8XC01-8YE0	PROFIBUS FastConnect bus cable Standard type with special design for quick mounting, 2-core, shielded, sold by the meter, max. delivery unit 1000 m, minimum ordering quantity 20 m
		6ES7 998-8XC01-8YE2 6ES7 972-0BA12-0XA0 6ES7 972-0BB12-0XA0 6ES7 972-0BA42-0XA0 6ES7 972-0BB42-0XA0 6ES7 972-0BA30-0XA0 6ES7 972-0BA52-0XA0 6ES7 972-0BA52-0XB0 6ES7 972-0BB52-0XA0 6ES7 972-0BB52-0XB0 6GK1 500-0EA02 6XV1 830-0EH10

SIMATIC S7-400

Central processing units

Sync-module for coupling the CPU 41xH

Overview



- For coupling the two CPU 41xH in the S7-400H subunits.
- Can be plugged direct into the CPU

Technical specifications

	6ES7 960-1AA06-0XA0	6ES7 960-1AB06-0XA0
Input current from CPU, max.	220 mA	240 mA
Power losses Power loss, typ.	0.77 W	0.83 W
Dimensions		
Width	13 mm	13 mm
Height	14 mm	14 mm
Depth	58 mm	58 mm
Weight Weight, approx.	14 g	14 g

Ordering data

Sync module

for coupling the CPU 41xH
for S7-400H/F/FH;
2 modules required per CPU;

for patch cable, can be used
with fiber-optic cables up to 10 m

for patch and installation cables,
can be used with fiber-optic cables
up to 10 km

Order No.

6ES7 960-1AA06-0XA0

6ES7 960-1AB06-0XA0

Fiber-optic connecting cable

For Sync module
6ES7 960-1Ax04-0XA0

- 1 m
- 2 m
- 10 m

For Sync module
6ES7 960-1AB06-0XA0;
fiber-optic monomode LC/LC duplex
crossed 9/125 μ (max. 10 km)

Order No.

6ES7 960-1AA04-5AA0
6ES7 960-1AA04-5BA0
6ES7 960-1AA04-5KA0

On request

SIMATIC S7-400

Central processing units

Y-link for S7-400H

Overview



- Transceiver for the transition from a redundant PROFIBUS DP master system to a single-channel PROFIBUS DP master system
- To connect devices with a single PROFIBUS DP interface to the redundant PROFIBUS DP master system of the SIMATIC S7-400H

Technical specifications

	6ES7 153-2BA02-0XB0
General information	
Vendor identification (VendorID)	801Eh
Supply voltage	
24 V DC	Yes
permissible range, lower limit (DC)	20.4 V
permissible range, upper limit (DC)	28.8 V
permissible range (ripple included), lower limit (DC)	20.4 V
permissible range (ripple included), upper limit (DC)	28.8 V
External protection for supply cables (recommendation)	2.5 A
Mains buffering	
• Mains/voltage failure stored energy time	5 ms
Input current	
Current consumption, max.	650 mA
Inrush current, typ.	3 A
I^2t	0.1 A ² ·s
Output voltage	
Rated value, 5 V DC	Yes
Output current	
for backplane bus (5 V DC), max.	1.5 A
Power losses	
Power loss, typ.	5.5 W
Address area	
Addressing volume	
• Outputs	244 byte
• Inputs	244 byte
Hardware configuration	
Number of modules per DP slave interface, max.	12

	6ES7 153-2BA02-0XB0
Time stamping	
Accuracy	1 ms; 1ms at up to 8 modules; 10ms at up to 12 modules
Number of message buffers	15
Messages per message buffer	20
Number of stampable digital inputs, max.	128; Max. 128 signals/station; max. 32 signals/slot
Time format	RFC 1119
Time resolution	0.466 ns
Time interval for transmitting the message buffer if a message is present	1 000 ms
Time stamp on signal change	rising / falling edge as signal entering or exiting
Interfaces	
Interface physics, RS 485	Yes
Interface physics, FOC	No
PROFIBUS DP	
• Node addresses	1 to 125 permitted
• Automatic detection of transmission speed	Yes
• PROFIBUS DP, output current, max.	70 mA
• Transmission procedure	RS 485
• Transmission rate, max.	12 Mbit/s
• SYNC capability	Yes
• FREECE capability	Yes
• Direct data exchange (slave-to-slave communication)	Yes; Sender
• PROFIBUS DP	9-pin sub D
1st interface	
DP slave	
• GSD file	SI04801.GSG
• Automatic baud rate search	Yes
Communication functions	
Bus protocol/transmission protocol	PROFIBUS DP to EN 50170

Technical specifications (continued)

6ES7 153-2BA02-0XB0	
Isolation	
Isolation checked with	Isolation voltage 500 V
Degree and class of protection	
IP20	Yes
Ambient conditions	
Operating temperature	
• Min.	0 °C
• max.	60 °C
Air pressure	
• Operating altitude above sea level, max.	3 000 m
Dimensions	
Width	40 mm
Height	125 mm
Depth	117 mm
Weight	
Weight, approx.	360 g

6ES7 197-1LB00-0XA0	
General information	
Requirements for DP master system	
• Length of parameter assignment message	244 byte
Supply voltage	
Description	via bus module
permissible range, lower limit (DC)	20.4 V
permissible range, upper limit (DC)	28.8 V
Interfaces	
PROFIBUS DP	
• Properties of the lower-level DP master systems	
- Transmission rate, max.	12 Mbit/s; 45.45 kbit/s to 12 Mbit/s
- Termination of lower-level DP master system	Active terminating resistor (Bus Terminator)
- Use of OLM/OBT	Yes
- Use of RS 485 repeaters, max.	9
- Number of DP slaves, max.	31; 64 when using RS 485 repeaters or OLM/OBT
Protocols	
PROFIBUS DP	Yes
Interrupts/diagnostics/status information	
Status indicator	No
Alarms	
• Alarms	No
Diagnostic messages	
• Diagnostic functions	Yes
Galvanic isolation	
to lower-level DP master system	Yes
Dimensions	
Width	40 mm
Height	125 mm
Depth	130 mm
Weight	
Weight, approx.	200 g

SIMATIC S7-400

Central processing units

Y-link for S7-400H

Ordering data

Order No.

Order No.

For use with STEP 7 from V5.4 or PCS 7 from V7.0:

Y link

For connecting single-channel DP slaves to SIMATIC S7-400H; consisting of
 2 IM 153 interface modules (6ES7 153-2BA02-0XB0),
 1 Y coupler (6ES7 197-1LB00-0XA0),
 1 BM IM/IM bus module (6ES7 195-7HD80-0XA0),
 1 BM Y coupler bus module (6ES7 654-7HY00-0XA0)

6ES7 197-1LA04-0XA0

For use with PCS 7 V6.0 or higher:

Y link

For connecting single-channel DP slaves to SIMATIC S7-400H; consisting of
 2 IM 153 interface modules (6ES7 153-2BA82-0XB0),
 1 Y coupler (6ES7 197-1LB00-0XA0),
 1 BM IM/IM bus module (6ES7 195-7HD80-0XA0),
 1 BM Y coupler bus module (6ES7 654-7HY00-0XA0)

6ES7 197-1LA11-0XA0

Accessories

Mounting rail

For assembling the Y link with active bus modules

- Length 483 mm
- Length 530 mm

6ES7 195-1GA00-0XA0
6ES7 195-1GF30-0XA0

SIMATIC S7-400

Central processing units

SIPLUS high-availability CPUs
SIPLUS CPU 412H

Overview



- CPU for SIMATIC S7-400H and S7-400F/FH
- Usable in high-availability systems such as the S7-400H
- Usable with F runtime license as F-capable CPU in S7-400F/FH safety-related systems
- Features a combined MPI/PROFIBUS DP master interface
- Features 2 slots for sync modules

Note:

SIPLUS extreme products are based on Siemens Industry standard products. The contents listed here were taken from the respective standard products. SIPLUS extreme specific information was added.

Technical specifications

The technical data correspond to those of the based-on modules apart from the values listed in the table:

	6AG1 412-3HJ14-4AB0	6AG1 412-2EK06-2AB0	6AG1 412-5HK06-7AB0
Based on	6ES7 412-3HJ14-0AB0	6ES7 412-2EK06-0AB0	6ES7412-5HK06-0AB0
Ambient conditions			
Extended ambient conditions			
<ul style="list-style-type: none"> • Relative to ambient temperature-atmospheric pressure-installation altitude 	Tmin ... Tmax at 1080 hPa ... 795 hPa (-1000 m ... +2000 m) // Tmin ... (Tmax - 10K) at 795 hPa ... 658 hPa (+2000 m ... +3500 m) // Tmin ... (Tmax - 20K) at 658 hPa ... 540 hPa (+3500 m ... +5000 m)	Tmin ... Tmax at 1080 hPa ... 795 hPa (-1000 m ... +2000 m) // Tmin ... (Tmax - 10K) at 795 hPa ... 658 hPa (+2000 m ... +3500 m) // Tmin ... (Tmax - 20K) at 658 hPa ... 540 hPa (+3500 m ... +5000 m)	Tmin ... Tmax at 1080 hPa ... 795 hPa (-1000 m ... +2000 m) // Tmin ... (Tmax - 10K) at 795 hPa ... 658 hPa (+2000 m ... +3500 m) // Tmin ... (Tmax - 20K) at 658 hPa ... 540 hPa (+3500 m ... +5000 m). For "F-Systems" applications max. +2000 m above sea level permissible
<ul style="list-style-type: none"> • Relative humidity <ul style="list-style-type: none"> - with condensation 	100 %; Relative humidity, incl. condensation / frost permitted (no commissioning under condensation conditions)	100 %; Relative humidity, incl. condensation / frost permitted (no commissioning under condensation conditions)	100 %; RH incl. condensation/frost (no commissioning under condensation conditions)
<ul style="list-style-type: none"> • Resistance <ul style="list-style-type: none"> - to biologically active substances 	Yes; Class 3B2 mold, fungus and dry rot spores (with the exception of fauna). The supplied connector covers must remain on the unused interfaces during operation!	Yes; Class 3B2 mold, fungus and dry rot spores (with the exception of fauna). The supplied connector covers must remain on the unused interfaces during operation in corrosive atmospheres!	Yes; Class 3B2 mold, fungus and dry rot spores (with the exception of fauna). The supplied connector covers must remain on the unused interfaces during operation!
<ul style="list-style-type: none"> - to chemically active substances 	Yes; Class 3C4 incl. salt spray according to EN 60068-2-52 (degree of severity 3). The supplied connector covers must remain on the unused interfaces during operation!	Yes; Class 3C4 incl. salt spray according to EN 60068-2-52 (degree of severity 3). The supplied connector covers must remain on the unused interfaces during operation!	Yes; Class 3C4 (RH < 75%) incl. salt spray according to EN 60068-2-52 (degree of severity 3). The supplied connector covers must remain on the unused interfaces during operation!
<ul style="list-style-type: none"> - to mechanically active substances 	Yes; Class 3S4 incl. sand, dust. The supplied connector covers must remain on the unused interfaces during operation!	Yes; Class 3S4 incl. sand, dust. The supplied connector covers must remain on the unused interfaces during operation!	Yes; Class 3S4 incl. sand, dust. The supplied connector covers must remain on the unused interfaces during operation!
Mechanical and climatic conditions during operation			
Climatic conditions in operation			
<ul style="list-style-type: none"> • Temperature <ul style="list-style-type: none"> - Min. - max. 	0 °C; = Tmin 60 °C; = Tmax	-25 °C; = Tmin 60 °C; = Tmax	-25 °C 70 °C; For "F-Systems" applications max. +60 °C permissible

SIMATIC S7-400

Central processing units

SIPLUS high-availability CPUs
SIPLUS CPU 412H

Ordering data

Order No.

SIPLUS CPU 412-3H

6AG1 412-3HJ14-4AB0

(medial exposure)

for S7-400H and S7-400F/FH;
768 KB work memory, combined
MPI/PROFIBUS DP master interface,
2 slots for sync modules, slot for
memory card, including the
mounting position labels

SIPLUS S7-400 CPU 412-2 PN

6AG1 412-2EK06-2AB0

(extended temperature range and
medial exposure)

For S7-400H and S7-400F/FH;
1 MB main memory
(512 KB for code, 512 KB for data).
2 interfaces:
MPI/DP 12 Mbit/s (X1)
Ethernet/PROFINET (X5)

SIPLUS S7-400 CPU 412-5H

6AG1 412-5HK06-7AB0

(extended temperature range and
medial exposure)

For S7-400H and S7-400F/FH;
1 MB main memory
(512 KB for code, 512 KB for data).
5 interfaces:
1 x MPI/DP
1 x DP
1 x PN
2 x for sync modules

Order No.

Accessories

Memory card RAM

(medial exposure)

2 MB

6AG1 952-1AL00-4AA0

4 MB

6AG1 952-1AM00-7AA0

8 MB

6AG1 952-1AP00-7AA0

16 MB

6AG1 952-1AS00-7AA0

64 MB

6AG1 952-1AY00-7AA0

FEPRAM memory card

(medial exposure)

32 MB

6AG1 952-1KT00-4AA0

RS 485 bus connector

with 90° cable outlet

(extended temperature range and
medial exposure)

Max. transfer rate 12 Mbit/s

Without PG interface

6AG1 972-0BA12-2XA0

With PG interface

6AG1 972-0BB12-2XA0

RS 485 bus connector

with angled cable outlet

(extended temperature range
-40°C ... +70°C and
medial exposure)

Max. transfer rate 12 Mbit/s

Without PG interface

6AG1 972-0BA42-7XA0

With PG interface

6AG1 972-0BB42-7XA0

Further accessories

See SIMATIC CPU 412,
page 6/39

SIMATIC S7-400

Central processing units

SIPLUS high-availability CPUs
SIPLUS CPU 414H

Overview



CPU for SIMATIC S7-400H and S7-400F/FH

- Usable in high-availability systems such as the S7-400H
- Usable with F runtime license as F-capable CPU in S7-400F/FH safety-related systems
- With integral PROFIBUS DP master interface
- Features 2 slots for sync modules

Note:

SIPLUS extreme products are based on Siemens Industry standard products. The contents listed here were taken from the respective standard products. SIPLUS extreme specific information was added.

Technical specifications

The technical data correspond to those of the based-on modules apart from the values listed in the table:

	6AG1 414-4HM14-4AB0	6AG1 414-3EM06-7AB0	6AG1 414-5HM06-7AB0
Based on	6ES7 414-4HM14-0AB0	6ES7 414-3EM06-0AB0	6ES7 414-5HM06-0AB0
Ambient conditions			
Extended ambient conditions			
• Relative to ambient temperature -atmospheric pressure-installation altitude	Tmin ... Tmax at 1080 hPa ... 795 hPa (-1000 m ... +2000 m) // Tmin ... (Tmax - 10K) at 795 hPa ... 658 hPa (+2000 m ... +3500 m) // Tmin ... (Tmax - 20K) at 658 hPa ... 540 hPa (+3500 m ... +5000 m)	Tmin ... Tmax at 1080 hPa ... 795 hPa (-1000 m ... +2000 m) // Tmin ... (Tmax - 10K) at 795 hPa ... 658 hPa (+2000 m ... +3500 m) // Tmin ... (Tmax - 20K) at 658 hPa ... 540 hPa (+3500 m ... +5000 m)	Tmin ... Tmax at 1080 hPa ... 795 hPa (-1000 m ... +2000 m) // Tmin ... (Tmax - 10K) at 795 hPa ... 658 hPa (+2000 m ... +3500 m) // Tmin ... (Tmax - 20K) at 658 hPa ... 540 hPa (+3500 m ... +5000 m). For "F-Systems" applications max. +2000 m above sea level permissible
• Relative humidity - with condensation	100 %; RH incl. condensation/frost (no commissioning under condensation conditions)	100 %; Relative humidity, incl. condensation / frost permitted (no commissioning under condensation conditions)	100 %; RH incl. condensation/frost (no commissioning under condensation conditions)
• Resistance - to biologically active substances	Yes; Class 3B2 mold, fungus and dry rot spores (with the exception of fauna). The supplied connector covers must remain on the unused interfaces during operation!	Yes; Class 3B2 mold, fungus and dry rot spores (with the exception of fauna). The supplied connector covers must remain on the unused interfaces during operation in corrosive atmospheres!	Yes; Class 3B2 mold, fungus and dry rot spores (with the exception of fauna). The supplied connector covers must remain on the unused interfaces during operation!
- to chemically active substances	Yes; Class 3C4 (RH < 75%) incl. salt spray according to EN 60068-2-52 (degree of severity 3). The supplied connector covers must remain on the unused interfaces during operation!	Yes; Class 3C4 incl. salt spray according to EN 60068-2-52 (degree of severity 3). The supplied connector covers must remain on the unused interfaces during operation!	Yes; Class 3C4 (RH < 75%) incl. salt spray according to EN 60068-2-52 (degree of severity 3). The supplied connector covers must remain on the unused interfaces during operation!
- to mechanically active substances	Yes; Class 3S4 incl. sand, dust. The supplied connector covers must remain on the unused interfaces during operation!	Yes; Class 3S4 incl. sand, dust. The supplied connector covers must remain on the unused interfaces during operation!	Yes; Class 3S4 incl. sand, dust. The supplied connector covers must remain on the unused interfaces during operation!
Mechanical and climatic conditions during operation			
Climatic conditions in operation			
• Temperature - Min. - max.	0 °C; = Tmin 60 °C; = Tmax	-25 °C; = Tmin 70 °C; = Tmax	-25 °C 70 °C; For "F-Systems" applications max. +60 °C permissible

SIMATIC S7-400

Central processing units

SIPLUS high-availability CPUs
SIPLUS CPU 414H

Ordering data

Order No.

Order No.

SIPLUS CPU 414-4H

(medial exposure)

For S7-400H and S7-400F/FH;
2.8 MB main memory, MPI/
PROFIBUS DP master interface,
2 slots for sync modules, slot for
memory card, incl. slot number
labels

6AG1 414-4HM14-4AB0

SIPLUS S7-400 CPU 414-3 PN/DP

(extended temperature range and
medial exposure)

4 MB main memory
(2 MB for code, 2 MB for data)

3 interfaces:
MPI/DP 12 Mbit/s (X1),
Ethernet/PROFINET (X5),
IF 964-DP pluggable (IF1)

6AG1 414-3EM06-7AB0

SIPLUS S7-400 CPU 414-5H

(extended temperature range and
medial exposure)

For S7-400H and S7-400F/FH;
1 MB main memory
(512 KB for code, 512 KB for data)

5 interfaces:
1 x MPI/DP
1 x DP
1 x PN
2 x for sync modules

6AG1 414-5MH06-7AB0

Accessories

Memory Card RAM

(medial exposure)

2 MB

(extended temperature range and
medial exposure)

4 MB

8 MB

16 MB

64 MB

6AG1 952-1AL00-4AA0

6AG1 952-1AM00-7AA0

6AG1 952-1AP00-7AA0

6AG1 952-1AS00-7AA0

6AG1 952-1AY00-7AA0

FEPR0M memory card

(medial exposure)

32 MB

6AG1 952-1KT00-4AA0

RS 485 bus connector with 90° cable outlet

(extended temperature range and
medial exposure)

Max. transfer rate 12 Mbit/s

Without PG interface

6AG1 972-0BA12-2XA0

With PG interface

6AG1 972-0BB12-2XA0

RS 485 bus connector with angled cable outlet

(extended temperature range and
medial exposure)

Max. transfer rate 12 Mbit/s

Without PG interface

6AG1 972-0BA42-7XA0

With PG interface

6AG1 972-0BB42-7XA0

Further accessories

See SIMATIC CPU 414-4H,
page 6/39

SIMATIC S7-400

Central processing units

SIPLUS high-availability CPUs
SIPLUS CPU 417H

Overview



CPU for SIMATIC S7-400H and S7-400F/FH

- Usable in high-availability systems such as the S7-400H
- Usable with F runtime license as F-capable CPU in S7-400F/FH safety-related systems
- With integral PROFIBUS DP master interface
- Features 2 slots for sync modules

Note:

SIPLUS extreme products are based on Siemens Industry standard products. The contents listed here were taken from the respective standard products. SIPLUS extreme specific information was added.

Technical specifications

	6AG1 417-4HT14-4AB0 6ES7 417-4HT14-0AB0	6AG1 417-4XT05-4AB0 6ES7 417-4XT05-0AB0	6AG1 417-5HT06-7AB0 6ES7 417-5HT06-0AB0
Based on			
Ambient conditions			
Extended ambient conditions			
• Relative to ambient temperature-atmospheric pressure-installation altitude	Tmin ... Tmax at 1080 hPa ... 795 hPa (-1000 m ... +2000 m) // Tmin ... (Tmax - 10K) at 795 hPa ... 658 hPa (+2000 m ... +3500 m) // Tmin ... (Tmax - 20K) at 658 hPa ... 540 hPa (+3500 m ... +5000 m)	Tmin ... Tmax at 1080 hPa ... 795 hPa (-1000 m ... +2000 m) // Tmin ... (Tmax - 10K) at 795 hPa ... 658 hPa (+2000 m ... +3500 m) // Tmin ... (Tmax - 20K) at 658 hPa ... 540 hPa (+3500 m ... +5000 m)	Tmin ... Tmax at 1080 hPa ... 795 hPa (-1000 m ... +2000 m) // Tmin ... (Tmax - 10K) at 795 hPa ... 658 hPa (+2000 m ... +3500 m) // Tmin ... (Tmax - 20K) at 658 hPa ... 540 hPa (+3500 m ... +5000 m). For "F-Systems" applications max. +2000 m above sea level permissible
• Relative humidity - with condensation	100 %; RH incl. condensation/frost (no commissioning under condensation conditions)	100 %; RH incl. condensation/frost (no commissioning under condensation conditions)	100 %; RH incl. condensation/frost (no commissioning under condensation conditions)
• Resistance - to biologically active substances	Yes; Class 3B2 mold, fungus and dry rot spores (with the exception of fauna). The supplied connector covers must remain on the unused interfaces during operation!	Yes; Class 3B2 mold, fungus and dry rot spores (with the exception of fauna). The supplied connector covers must remain on the unused interfaces during operation!	Yes; Class 3B2 mold, fungus and dry rot spores (with the exception of fauna). The supplied connector covers must remain on the unused interfaces during operation!
- to chemically active substances	Yes; Class 3C4 (RH < 75%) incl. salt spray according to EN 60068-2-52 (degree of severity 3). The supplied connector covers must remain on the unused interfaces during operation!	Yes; Class 3C4 (RH < 75%) incl. salt spray according to EN 60068-2-52 (degree of severity 3). The supplied connector covers must remain on the unused interfaces during operation!	Yes; Class 3C4 incl. salt spray according to EN 60068-2-52 (degree of severity 3). The supplied connector covers must remain on the unused interfaces during operation!
- to mechanically active substances	Yes; Class 3S4 incl. sand, dust. The supplied connector covers must remain on the unused interfaces during operation!	Yes; Class 3S4 incl. sand, dust. The supplied connector covers must remain on the unused interfaces during operation!	Yes; Class 3S4 incl. sand, dust. The supplied connector covers must remain on the unused interfaces during operation!
Mechanical and climatic conditions during operation			
Climatic conditions in operation			
• Temperature - Min. - max.	0 °C; = Tmin 60 °C; = Tmax	0 °C; = Tmin 60 °C; = Tmax	-25 °C 70 °C; For "F-Systems" applications max. +60 °C permissible

SIMATIC S7-400

Central processing units

SIPLUS high-availability CPUs
SIPLUS CPU 417H

Ordering data

Order No.

SIPLUS CPU 417H

(medial exposure)

For S7-400H and S7-400F/FH;
30 MB work memory, MPI/
PROFIBUS DP master interface,
2 slots for sync modules, slot for
memory card, incl. slot number
plates

6AG1 417-4HT14-4AB0

SIPLUS S7-400 CPU417-4

(medial exposure)

For S7-400H and S7-400F/FH.
Based on 6ES7 417-4XT05-0AB0

6AG1 417-4XT05-4AB0

SIPLUS S7-400 CPU 417-5H

(extended temperature range and
medial exposure)

For S7-400H and S7-400F/FH;
1 MB main memory
(512 KB for code, 512 KB for data)

5 interfaces:

1 x MPI/DP

1 x DP

1 x PN

2 x for sync modules

6AG1 417-5HT06-7AB0

Order No.

Accessories

Memory card RAM

(medial exposure)

2 MB

(extended temperature range and
medial exposure)

4 MB

8 MB

16 MB

64 MB

6AG1 952-1AL00-4AA0

6AG1 952-1AM00-7AA0

6AG1 952-1AP00-7AA0

6AG1 952-1AS00-7AA0

6AG1 952-1AY00-7AA0

FEPR0M memory card

(medial exposure)

32 MB

6AG1 952-1KT00-4AA0

RS 485 bus connector with 90° cable outlet

(extended temperature range and
medial exposure)

Max. transmission rate 12 Mbit/s

Without PG interface

6AG1 972-0BA12-2XA0

With PG interface

6AG1 972-0BB12-2XA0

RS 485 bus connector with angled cable outlet

(extended temperature range and
medial exposure)

Max. transfer rate 12 Mbit/s

Without PG interface

6AG1 972-0BA42-7XA0

With PG interface

6AG1 972-0BB42-7XA0

Further accessories

See SIMATIC CPU 417-4H,
page 6/39

SIMATIC S7-400

Central processing units

SIPLUS sync module
for connecting the CPU 41xH

Overview



- For linking the two CPUs 414-4H/417-4H in the subunits of the S7-400H
- Can be plugged directly into the CPU

Note:

SIPLUS extreme products are based on Siemens Industry standard products. The contents listed here were taken from the respective standard products. SIPLUS extreme specific information was added.

Technical specifications

	6ES7 960-1AA04-4XA0	6ES7 960-1AB04-4XA0	6ES7 960-1AA06-7XA0	6ES7 960-1AB06-7XA0
Based on	6ES7 960-1AA04-0XA0	6ES7 960-1AB04-0XA0	6ES7 960-1AA06-0XA0	6ES7 960-1AB06-0XA0
Current consumption from CPU, max.	210 mA	250 mA	220 mA	240 mA
Power dissipation, typ.	1.1 mW	1.3 mW	0.77 mW	0.83 mW
Extended range of environmental conditions				
• Temperatures	0 °C ... 60 °C	0 °C ... 60 °C	-25 °C ... +70 °C	-25 °C ... +70 °C
• Temperatures with reference to ambient temperature, air pressure and altitude	0 °C ... +60 °C at 1080 hPa ... 795 hPa (-1000 m ... +2000 m)	0 °C ... +60 °C at 1080 hPa ... 795 hPa (-1000 m ... +2000 m)	-25 °C ... +70 °C at 1080 hPa ... 795 hPa (-1000 m ... +2000 m)	-25 °C ... +70 °C at 1080 hPa ... 795 hPa (-1000 m ... +2000 m)
	0 °C ... +50 °C at 795 hPa ... 658 hPa (+2000 m ... +3500 m)	0 °C ... +50 °C at 795 hPa ... 658 hPa (+2000 m ... +3500 m)	-25 °C ... +60 °C at 795 hPa ... 658 hPa (+2000 m ... +3500 m)	-25 °C ... +60 °C at 795 hPa ... 658 hPa (+2000 m ... +3500 m)
	0 °C ... +40 °C at 658 hPa ... 540 hPa (+3500 m ... +5000 m)	0 °C ... +40 °C at 658 hPa ... 540 hPa (+3500 m ... +5000 m)	-25 °C ... +50 °C at 658 hPa ... 540 hPa (+3500 m ... +5000 m)	-25 °C ... +50 °C at 658 hPa ... 540 hPa (+3500 m ... +5000 m)
Relative humidity (with condensation / maximum)	100 %, incl. condensation/frost (no commissioning in bedewed state)	100 %, incl. condensation/frost (no commissioning in bedewed state)	100 %, incl. condensation/frost (no commissioning in bedewed state)	100 %, incl. condensation/frost (no commissioning in bedewed state)
Resistance				
• to biologically active substances / compliance with EN 60721-3-3	Yes; Class 3B2 mold and fungal spores (excluding fauna). The supplied plug covers must remain in place over the unused interfaces during operation.	Yes; Class 3B2 mold and fungal spores (excluding fauna). The supplied plug covers must remain in place over the unused interfaces during operation.	Yes; Class 3B2 mold and fungal spores (excluding fauna). The supplied plug covers must remain in place over the unused interfaces during operation.	Yes; Class 3B2 mold and fungal spores (excluding fauna). The supplied plug covers must remain in place over the unused interfaces during operation.
• to chemically active substances / compliance with EN 60721-3-3	Yes; Class 3C4 (relative humidity < 75 %) incl. salt spray in accordance with EN 60068-2-52 (degree of severity 3). The supplied plug covers must remain in place over the unused interfaces during operation.	Yes; Class 3C4 (relative humidity < 75 %) incl. salt spray in accordance with EN 60068-2-52 (degree of severity 3). The supplied plug covers must remain in place over the unused interfaces during operation.	Yes; Class 3C4 (relative humidity < 75 %) incl. salt spray in accordance with EN 60068-2-52 (degree of severity 3). The supplied plug covers must remain in place over the unused interfaces during operation.	Yes; Class 3C4 (relative humidity < 75 %) incl. salt spray in accordance with EN 60068-2-52 (degree of severity 3). The supplied plug covers must remain in place over the unused interfaces during operation.
• to mechanically active substances, compliance with EN 60721-3-3	Yes; Class 3S4 incl. sand, dust. The supplied plug covers must remain in place over the unused interfaces during operation.	Yes; Class 3S4 incl. sand, dust. The supplied plug covers must remain in place over the unused interfaces during operation.	Yes; Class 3S4 incl. sand, dust. The supplied plug covers must remain in place over the unused interfaces during operation.	Yes; Class 3S4 incl. sand, dust. The supplied plug covers must remain in place over the unused interfaces during operation.
Dimensions				
• Width	25 mm	25 mm	13 mm	13 mm
• Height	53 mm	53 mm	14 mm	14 mm
• Depth	140 mm	140 mm	58 mm	58 mm
Cable length, max.	10 m	10 km	10 m	10 km
Weight, approx.	65 g	65 g	14 g	14 g

SIMATIC S7-400

Central processing units

SIPLUS sync module for connecting the CPU 41xH

Ordering data	Order No.		Order No.
SIPLUS sync module (medial exposure) for coupling the CPU 41xH for S7-400H/F/FH; 2 modules required per CPU; <ul style="list-style-type: none"> for patch cable, can be used with fiber-optic cables up to 10 m for patch and installation cables, can be used with fiber-optic cables up to 10 km 	6AG1 960-1AA04-4XA0 6AG1 960-1AB04-4XA0	Accessories SIPLUS S7-400 OPTICAL FIBER CABLE 1M HF-S 1 m 2 m 10 m	see SIMATIC sync module, page 6/41 6AG1 960-1AA04-7AA0 6AG1 960-1AA04-7BA0 6AG1960-1AA04-7KA0
SIPLUS sync module (extended temperature range -25 °C ... +70 °C and medial exposure) <ul style="list-style-type: none"> for patch cable, can be used with fiber-optic cables up to 10 m for patch and installation cables, can be used with fiber-optic cables up to 10 km 	6AG1 960-1AA06-7XA0 6AG1 960-1AB06-7XA0		

Overview



- Bus coupler for transition from a redundant PROFIBUS DP master system to a single-channel PROFIBUS DP master system
- For connection of devices with only one PROFIBUS DP interface to the redundant PROFIBUS DP master system of the SIMATIC S7-400H

Note:

SIPLUS extreme products are based on Siemens Industry standard products. The contents listed here were taken from the respective standard products. SIPLUS extreme specific information was added.

	SIPLUS Y-Link for S7-400H	SIPLUS S7 BUS MODULE BM Y coupler
Order No.	6AG1 197-1LA11-4XA0	6AG1 654-7HY00-7XA0
Order No. based on	6ES7 197-1LA11-0XA0	6ES7 654-7HY00-0XA0
Ambient temperature range	0 °C ... +60 °C	-25 °C ... +70 °C
Conformal coating	Coating of the printed circuit boards and the electronic components	
Technical data	The technical data of the standard product applies except for the ambient conditions.	

Ambient conditions

Relative humidity	100%, condensation/frost permissible. No commissioning if condensation present.
Biologically active substances, compliance with EN 60721-3-3	Class 3B2 mold and fungal spores (excluding fauna). The supplied plug covers must remain in place over the unused interfaces during operation!
Chemically active substances, compliance with EN 60721-3-3	Class 3C4 incl. salt spray in accordance with EN60068-2-52 (degree of severity 3). The supplied plug covers must remain in place over the unused interfaces during operation!
Mechanically active substances, compliance with EN 60721-3-3	Class 3S4 incl. sand, dust. The supplied plug covers must remain in place over the unused interfaces during operation!
Air pressure (depending on the highest positive temperature range specified)	1 080 ... 795 hPa (-1 000 ... +2 000 m) see ambient temperature range 795 ... 658 hPa (+2 000 ... +3 500 m) derating 10 K 658 ... 540 hPa (+3 500 ... +5 000 m) derating 20 K

For technical documentation on SIPLUS, see:
www.siemens.com/siplus-extreme

Ordering data	Order No.	Order No.
For use with STEP 7 from V5.4 or PCS 7 from V7.0:		
SIPLUS Y-Link for S7-400H (medial exposure)	6AG1 197-1LA11-4XA0	
for connecting single-channel DP slaves to SIMATIC S7-400H; consisting of 2 IM 153 interface modules, 1 Y-coupler, 1 BM IM/IM bus module, 1 BM Y-coupler bus module		
	Accessories	
	SIPLUS S7 BUS MODULE BM Y-coupler (extended temperature range and medial exposure)	6AG1 654-7HY00-7XA0
	Additional accessories	See SIMATIC Y-Link, page 6/44

SIMATIC S7-400

Central processing units

Interface modules

PROFIBUS IF-964 DP module

Overview



- To connect distributed I/Os over PROFIBUS DP
- Max. transmission rate 12 Mbit/s
- Electrically isolated RS 485 interface
- Connection via 9-pin sub-D connector
- The following connection options are available for each S7-400 CPU:
 - A PROFIBUS module in the CPUs 414-3, 414(F)-3 PN/DP, 416-3, 416(F)-3 PN/DP
 - Two PROFIBUS modules in the CPU 417-4

Note:

Can only be used with CPUs 6ES7 414-3XM05-0AB0, 6ES7 414-3EM05-0AB0, 6ES7 414-3EM06-0AB0, 6ES7 414-3FM06-0AB0, 6ES7 416-3XR05-0AB0, 6ES7 416-3ER05-0AB0, 6ES7 416-3ES06-0AB0, 6ES7 416-3FS06-0AB0 and 6ES7 417-4XT05-0AB0.

Technical specifications

6ES7 964-2AA04-0AB0	
Input current from CPU, max.	150 mA; Current consumption from S7-400 bus: The module uses no current at 24 V, it provides this voltage only at the DP interface. Total current consumption of the components connected to the DP interface, but maximum 150 mA. Current carrying capacity of the isolated 5 V (P5ext) maximum 90 mA, current carrying capacity of the 24 V maximum 150 mA.
Power losses Power loss, typ.	1 W
Interfaces PROFIBUS DP • Cable length, max.	1 200 m; At 9.6 kbit/s: max. 1200 m; at 12 Mbit/s: max. 100 m
1st interface Physics	RS 485
Isolated	Yes
Functionality • DP master • DP slave	Yes; Default setting Yes
DP master • Transmission rate, max. • Transmission rate, min. • Number of DP slaves, max. • Services - PG/OP communication - Equidistance mode support - SYNC/FREEZE - Direct data exchange (slave-to-slave communication)	12 Mbit/s 9.6 kbit/s 125; depending on the CPU used Yes Yes Yes Yes
• Address area - Inputs, max. - Outputs, max.	device-dependent device-dependent
• User data per DP slave - Inputs, max. - Outputs, max.	244 byte 244 byte
Communication functions Number of connections • overall	device-dependent
Dimensions Width	26 mm
Height	54 mm
Depth	130 mm
Weight Weight, approx.	65 g

Ordering data

Order No.

IF-964 DP interface module
Interface module with integral PROFIBUS DP master interface

6ES7 964-2AA04-0AB0

SIMATIC S7-400

Central processing units

SIPLUS PROFIBUS IF-964 DP module

Overview



- To connect distributed I/O via PROFIBUS DP
- Max. transmission rate 12 Mbit/s
- Electrically isolated RS-485 interface
- Connection via 9-pin Sub-D socket
- Depending on the S7-400 CPU, one or two pluggable PROFIBUS modules:
 - CPU 414-3/416-3: 1 module
 - CPU 417-4: 2 modules

Notes:

Can only be used with the CPUs 6AG1 416-3XR05-4AB0, 6AG1 416-3ER05-4AB0 and 6AG1 417-4XT05-4AB0.

SIPLUS extreme products are based on Siemens Industry standard products. The contents listed here were taken from the respective standard products. SIPLUS extreme-specific information was added.

SIPLUS PROFIBUS IF-964 DP module	
Order No.	6AG1 964-2AA04-7AB0
Order No. based on	6ES7 964-2AA04-0AB0
Ambient temperature range	-25 ... +70 °C
Conformal coating	Coating of the printed circuit boards and the electronic components
Technical data	The technical data of the standard product applies except for the ambient conditions.
Ambient conditions	
Relative humidity	100%, condensation/frost permissible. No commissioning if condensation present.
Biologically active substances, compliance with EN 60721-3-3	Class 3B2 mold and fungal spores (excluding fauna). The supplied plug covers must remain in place over the unused interfaces during operation!
Chemically active substances, compliance with EN 60721-3-3	Class 3C4 incl. salt spray in accordance with EN60068-2-52 (degree of severity 3). The supplied plug covers must remain in place over the unused interfaces during operation!
Mechanically active substances, compliance with EN 60721-3-3	Class 3S4 incl. sand, dust. The supplied plug covers must remain in place over the unused interfaces during operation!
Air pressure (depending on the highest positive temperature range specified)	1080 ... 795 hPa (-1000 ... +2000 m) see ambient temperature range 795 ... 658 hPa (+2000 ... +3500 m) derating 10 K 658 ... 540 hPa (+3500 ... +5000 m) derating 20 K

For further technical documentation on SIPLUS, see:
www.siemens.com/siplus-extreme

Ordering data	Order No.
SIPLUS IF-964 DP interface module	6AG1 964-2AA04-7AB0
(extended temperature range and medial exposure)	
Interface module with integrated PROFIBUS DP master interface	

SIMATIC S7-400

Digital modules

SM 421 digital input module

Overview



- Digital inputs for the SIMATIC S7-400
- For connecting standard switches and two-wire proximity switches (BERO)

Technical specifications

	6ES7 421-7BH01-0AB0	6ES7 421-1BL01-0AA0	6ES7 421-1EL00-0AA0	6ES7 421-1FH20-0AA0	6ES7 421-7DH00-0AB0
Supply voltage					
Load voltage L+					
• Rated value (DC)	24 V				
• permissible range, lower limit (DC)	20.4 V				
• permissible range, upper limit (DC)	28.8 V				
Input current					
from backplane bus 5 V DC, max.	130 mA	20 mA	200 mA	80 mA	150 mA
from supply voltage L+, max.	120 mA				
Power losses					
Power loss, max.	5 W	6 W	16 W	12 W	8 W; 3.5 W (24 V DC); 6.5 W (48 V DC); 8.0 W (60 V DC)
Digital inputs					
Number/binary inputs	16	32	32	16	16
Number of simultaneously controllable inputs					
• all mounting positions					
- up to 40 °C, max.	16	32	32	16	16
- up to 60 °C, max.	16	32	32	16	16
Input voltage					
• Type of input voltage	DC	DC	AC/DC	AC/DC	AC/DC
• Rated value, DC	24 V	24 V			
• Rated value, UC			120 V	230 V; 120/230 V UC	24 V; 24 to 60 V UC
• for signal "0"	-30 to +5 V DC	-30 to +5 V DC	0 to 20 V UC	0 to 40 V AC/ -40 to +40 V DC	-6 to +6 V DC/ 0 to 5 V AC
• for signal "1"	11 to 30 V DC	13 to 30 V DC	79 to 132 V AC; 80 to 132 V DC	74 to 264 V AC; 80 to 264 V DC, -80 to -264 V	15 to 72 V DC; -15 to -72 V DC; 15 to 60 V AC
• Frequency range			47 to 63 Hz	47 to 63 Hz	47 to 63 Hz AC / DC

Technical specifications (continued)

	6ES7 421-7BH01-0AB0	6ES7 421-1BL01-0AA0	6ES7 421-1EL00-0AA0	6ES7 421-1FH20-0AA0	6ES7 421-7DH00-0AB0
Input current <ul style="list-style-type: none"> for signal "0", max. (permissible quiescent current) for signal "1", typ. 	6 mA; 6 to 8 mA	1.3 mA 7 mA	1 mA 2 mA; 2 to 5 mA	6 mA; AC: 6 mA; DC: 2 mA 10 mA; at 120 V: 10 mA AC, 1.8 mA DC; at 230 V: 14 mA AC, 2 mA DC	4 mA; 4 to 10 mA
Input delay (for rated value of input voltage) <ul style="list-style-type: none"> for standard inputs <ul style="list-style-type: none"> Parameterizable Rated value 	Yes				Yes 0.5 ms; 0.5 / 3 / 10 / 20 ms
Cable length <ul style="list-style-type: none"> Cable length, shielded, max. Cable length unshielded, max. 	1 000 m; 1000 m/3 ms; 70 m/0.5 ms; 30 m/0.1 ms; 30 m/0.05 ms 600 m; 600 m: 3 ms; 50 m: 0.5 ms; 20 m: 0.1 ms; 20 m: 0.05 ms	1 000 m 600 m	1 000 m 600 m	1 000 m 600 m	1 000 m 600 m; 600 m: 3, 10, 20 ms; 100 m: 0.5 ms
Encoder Connectable encoders <ul style="list-style-type: none"> 2-wire sensor <ul style="list-style-type: none"> Permissible quiescent current (2-wire sensor), max. 	Yes 3 mA	Yes 1.5 mA	Yes 1 mA	Yes 5 mA; AC: 5 mA	Yes 0.5 mA; 0.5 to 2 mA
Interrupts/diagnostics/status information Alarms <ul style="list-style-type: none"> Diagnostic alarm Hardware interrupt 	Yes; Parameterizable Yes; Parameterizable				Yes; Parameterizable Yes; Parameterizable
Diagnostic messages <ul style="list-style-type: none"> Diagnostics 	Yes; internal/external fault				Yes; internal/external fault
Galvanic isolation Galvanic isolation digital inputs <ul style="list-style-type: none"> between the channels, in groups of between the channels and the backplane bus 	8 Yes	32 Yes	8 Yes	4 Yes	1 Yes
Isolation Isolation checked with	500 V DC	500 V DC	1500 V AC	1500 V AC	1500 V AC
Dimensions Width	25 mm	25 mm	25 mm	25 mm	25 mm
Height	290 mm	290 mm	290 mm	290 mm	290 mm
Depth	210 mm	210 mm	210 mm	210 mm	210 mm
Weight Weight, approx.	600 g	500 g	600 g	650 g	600 g

SIMATIC S7-400

Digital modules

SM 421 digital input module

Ordering data

SM 421 digital input modules

16 inputs, 24 V DC, with process/diagnostics interrupt

6ES7 421-7BH01-0AB0

32 inputs, 24 V DC

6ES7 421-1BL01-0AA0

32 inputs, 120 V AC/DC

6ES7 421-1EL00-0AA0

16 inputs, 120/230 V AC/DC, inputs according to IEC 1131-2 Type 2

6ES7 421-1FH20-0AA0

16 inputs, 24 to 60 V AC/DC, with process/diagnostics interrupt

6ES7 421-7DH00-0AB0

Front connector

48-pin

- with screw contacts, 1 unit
- with screw contacts, 84 units
- with spring-loaded terminals, 1 unit
- with crimp contacts, 1 unit
- with crimp contacts, 84 units

6ES7 492-1AL00-0AA0

6ES7 492-1AL00-1AB0

6ES7 492-1BL00-0AA0

6ES7 492-1CL00-0AA0

6ES7 492-1CL00-1AB0

SIMATIC TOP connect

See page 6/129; for information about which components can be used for the respective module, see Industry Mall

Order No.

Cover film for labeling strips

6ES7 492-2XX00-0AA0

Spare part

Labeling sheets for machine inscription

DIN A4, for printing using laser printer; pack of 10

petrol

6ES7 492-2AX00-0AA0

light-beige

6ES7 492-2BX00-0AA0

yellow

6ES7 492-2CX00-0AA0

red

6ES7 492-2DX00-0AA0

SIMATIC Manual Collection

6ES7 998-8XC01-8YE0

Electronic manuals on DVD, multilingual: LOGO!, SIMADYN, SIMATIC bus components, SIMATIC C7, SIMATIC distributed I/O, SIMATIC HMI, SIMATIC Sensors, SIMATIC NET, SIMATIC PC Based Automation, SIMATIC PCS 7, SIMATIC PG/PC, SIMATIC S7, SIMATIC Software, SIMATIC TDC

SIMATIC Manual Collection update service for 1 year

6ES7 998-8XC01-8YE2

Current "Manual Collection" DVD and the three subsequent updates

Overview



- Digital outputs for the SIMATIC S7-400
- For connecting solenoid valves, contactors, low-power motors, lamps and motor starters

Technical specifications

	6ES7 422-1FH00-0AA0	6ES7 422-1HH00-0AA0	6ES7 422-1BH11-0AA0	6ES7 422-1BL00-0AA0	6ES7 422-7BL00-0AB0
Supply voltage					
Load voltage L+					
• Rated value (DC)		60 V	24 V	24 V	24 V
• permissible range, lower limit (DC)		1 V	20.4 V	20.4 V	20.4 V
• permissible range, upper limit (DC)		60 V	28.8 V	28.8 V	28.8 V
Load voltage L1					
• Rated value (AC)	230 V; 120/230 V AC	230 V			
• permissible range, lower limit (AC)	79 V	2 V			20.4 V
• permissible range, upper limit (AC)	264 V	264 V			28.8 V
Input current					
from load voltage L+ (without load), max.	1.5 mA		30 mA	30 mA	120 mA
from load voltage L1 (without load), max.	6 mA				
from backplane bus 5 V DC, max.	400 mA	1 A	160 mA	200 mA	200 mA
Power losses					
Power loss, max.	16 W	25 W	7 W	4 W	8 W
Digital outputs					
Number/binary outputs	16	16; Relay	16	32	32
Limitation of inductive shutdown voltage to			-30 V	-27 V	L+ (-45 V)
Lamp load, max.	50 W	60 W	10 W	5 W	5 W
Output voltage					
• for signal "1", min.	L1 (-18.1 V)		L+ (-0.5 V)	L+ (-0.3 V)	L+ (-0.8 V)
Output current					
• for signal "1" rated value	2 A	5 A	2 A	0.5 A	0.5 A
• for signal "1" permissible range for 0 to 60 °C, min.	10 mA		5 mA	5 mA	5 mA
• for signal "1" permissible range for 0 to 60 °C, max.			2.4 A	0.6 A	0.6 A
• for signal "0" residual current, max.	2.6 mA		0.5 mA	0.3 mA	0.5 mA

SIMATIC S7-400

Digital modules

SM 422 digital output module

Technical specifications (continued)

	6ES7 422-1FH00-0AA0	6ES7 422-1HH00-0AA0	6ES7 422-1BH11-0AA0	6ES7 422-1BL00-0AA0	6ES7 422-7BL00-0AB0
Switching frequency • with resistive load, max. • with inductive load, max.	10 Hz 0.5 Hz	10 Hz	100 Hz 0.1 Hz	100 Hz 0.5 Hz	100 Hz 2 Hz
Aggregate current of outputs (per group) • all mounting positions - up to 60 °C, max.	2 A; 5 A with fan subassembly; per 4 adjacent outputs	5 mA; 10 A with fan subassembly	2 A; 2 adjacent outputs each	2 A; 8 adjacent outputs each	2 A
Relay outputs • Number of operating cycles, max. • Switching capacity of contacts - with inductive load, max. - Switching frequency/contacts/at ohmic load/maximum		100 000; 100,000 (AC 15 / DC 13); 3,000,000 mechanical 5 A; 5 A (30 V DC); 5 A (230 V AC) 5 A; 5 A (30 V DC); 5 A (230 V AC); 1.2 A (60 V DC); 0.2 A (125 V DC)			
Cable length • Cable length, shielded, max. • Cable length unshielded, max.	1 000 m 600 m	1 000 m 600 m	1 000 m 600 m	1 000 m 600 m	1 000 m 600 m
Interrupts/diagnostics/status information Alarms • Diagnostic alarm					Yes; Parameterizable
Diagnostic messages • Diagnostics					Yes; internal/external fault
Galvanic isolation Galvanic isolation digital outputs • between the channels, in groups of • between the channels and the backplane bus	4 Yes	2 Yes	8 Yes	32 Yes	8 Yes
Isolation Isolation checked with	1500 V AC	1500 V AC	500 V DC	500 V DC	500 V DC
Dimensions Width	25 mm	25 mm	25 mm	25 mm	25 mm
Height	290 mm	290 mm	290 mm	290 mm	290 mm
Depth	210 mm	210 mm	210 mm	210 mm	210 mm
Weight Weight, approx.	800 g	700 g	600 g	600 g	600 g

Ordering data	Order No.		Order No.
SM 422 digital output modules		Labeling sheets for machine inscription	
16 outputs, 24 V DC; 2 A	6ES7 422-1BH11-0AA0	DIN A4, for printing using laser printer; pack of 10	
32 outputs, 24 V DC; 0.5 A	6ES7 422-1BL00-0AA0	petrol	6ES7 492-2AX00-0AA0
32 outputs, 24 V DC, 0.5 A; with diagnostics	6ES7 422-7BL00-0AB0	light-beige	6ES7 492-2BX00-0AA0
16 outputs, 120/230 V AC; 2 A	6ES7 422-1FH00-0AA0	yellow	6ES7 492-2CX00-0AA0
16 outputs, relay contacts	6ES7 422-1HH00-0AA0	red	6ES7 492-2DX00-0AA0
Front connector		SIMATIC Manual Collection	6ES7 998-8XC01-8YE0
48-pin		Electronic manuals on DVD, multilingual: LOGO!, SIMADYN, SIMATIC bus components, SIMATIC C7, SIMATIC distributed I/O, SIMATIC HMI, SIMATIC Sensors, SIMATIC NET, SIMATIC PC Based Automation, SIMATIC PCS 7, SIMATIC PG/PC, SIMATIC S7, SIMATIC Software, SIMATIC TDC	
• with screw contacts, 1 unit	6ES7 492-1AL00-0AA0		
• with screw contacts, 84 units	6ES7 492-1AL00-1AB0		
• with spring-loaded terminals, 1 unit	6ES7 492-1BL00-0AA0		
• with crimp contacts, 1 unit	6ES7 492-1CL00-0AA0		
• with crimp contacts, 84 units	6ES7 492-1CL00-1AB0		
SIMATIC TOP connect	See page 6/129	SIMATIC Manual Collection update service for 1 year	6ES7 998-8XC01-8YE2
Cover film for labeling strips	6ES7 492-2XX00-0AA0	Current "Manual Collection" DVD and the three subsequent updates	
Spare part			

SIMATIC S7-400

SIPLUS digital modules

SIPLUS SM 421 digital input module

Overview



- Digital inputs for SIMATIC S7-400
- For connection of switches and 2-wire proximity switches (BEROs)

Note:

SIPLUS extreme products are based on Siemens Industry standard products. The contents listed here were taken from the respective standard products. SIPLUS extreme specific information was added.

SIPLUS SM 421 digital input module

Order number	6AG1 421-1BL01-2AA0
Order No. based on	6ES7 421-1BL01-0AA0
Ambient temperature range	-25 ... +60 °C
Conformal coating	Coating of the printed circuit boards and the electronic components
Technical data	The technical data of the standard product applies except for the ambient conditions
Ambient conditions	
Relative humidity	100%, condensation/frost permissible. No commissioning if condensation present.
Biologically active substances, compliance with EN 60721-3-3	Class 3B2 mold and fungal spores (excluding fauna). The supplied plug covers must remain in place over the unused interfaces during operation!
Chemically active substances, compliance with EN 60721-3-3	Class 3C4 incl. salt spray in accordance with EN60068-2-52 (degree of severity 3). The supplied plug covers must remain in place over the unused interfaces during operation!
Mechanically active substances, compliance with EN 60721-3-3	Class 3S4 incl. sand, dust. The supplied plug covers must remain in place over the unused interfaces during operation!
Air pressure (depending on the highest positive temperature range specified)	1080 ... 795 hPa (-1000 ... +2000 m) see ambient temperature range 795 ... 658 hPa (+2000 ... +3500 m) derating 10 K 658 ... 540 hPa (+3500 ... +5000 m) derating 20 K

For technical documentation on SIPLUS, see:
www.siemens.com/siplus-extreme

Ordering data	Order No.
SIPLUS SM 421 digital input modules (extended temperature range and medial exposure) 32 inputs, 24 V DC	6AG1 421-1BL01-2AA0
Accessories	

SIMATIC S7-400

SIPLUS digital modules

SIPLUS SM 422 digital output module

Overview



- Digital outputs for SIMATIC S7-400
- For connecting solenoid valves, contactors, small-power motors, lamps and motor starters

Note:

SIPLUS extreme products are based on Siemens Industry standard products. The contents listed here were taken from the respective standard products. SIPLUS extreme specific information was added.

SIPLUS SM 422 digital input module

Order number	6AG1 422-1BL00-2AA0
Order No. based on	6ES7 422-1BL00-0AA0
Ambient temperature range	-25 ... +60 °C
Conformal coating	Coating of the printed circuit boards and the electronic components
Technical data	The technical data of the standard product applies except for the ambient conditions
Ambient conditions	
Relative humidity	100%, condensation/frost permissible. No commissioning if condensation present.
Biologically active substances, compliance with EN 60721-3-3	Class 3B2 mold and fungal spores (excluding fauna). The supplied plug covers must remain in place over the unused interfaces during operation!
Chemically active substances, compliance with EN 60721-3-3	Class 3C4 incl. salt spray in accordance with EN60068-2-52 (degree of severity 3). The supplied plug covers must remain in place over the unused interfaces during operation!
Mechanically active substances, compliance with EN 60721-3-3	Class 3S4 incl. sand, dust. The supplied plug covers must remain in place over the unused interfaces during operation!
Air pressure (depending on the highest positive temperature range specified)	1080 ... 795 hPa (-1000 ... +2000 m) see ambient temperature range 795 ... 658 hPa (+2000 ... +3500 m) derating 10 K 658 ... 540 hPa (+3500 ... +5000 m) derating 20 K

For technical documentation on SIPLUS, see:
www.siemens.com/siplus-extreme

Ordering data	Order No.
SIPLUS SM 422 digital output modules (extended temperature range and medial exposure) 32 outputs, 24 V DC	6AG1 422-1BL00-2AA0
Accessories	See SIMATIC S7-400 digital output modules, page 6/61

SIMATIC S7-400

Analog modules

SM 431 analog input module

Overview



- Analog inputs for the SIMATIC S7-400
- For connection of voltage and current sensors, thermocouples, resistors and resistance thermometers
- Resolution from 13 to 16 bit

Technical specifications

	6ES7 431-0HH00-0AB0	6ES7 431-1KF20-0AB0	6ES7 431-1KF00-0AB0	6ES7 431-1KF10-0AB0
Supply voltage				
Load voltage L+				
• Rated value (DC)	24 V; Only required for supplying 2-wire transmitters	24 V; Only required for supplying 2-wire transmitters	not necessary	24 V; Only required for supplying 2-wire transmitters
• Reverse polarity protection	Yes	Yes		Yes
Input current				
from load voltage L+ (without load), max.	400 mA; for 16 connected, fully controlled 2-wire transmitters	200 mA; for 8 connected, fully controlled 2-wire transmitters		200 mA
from backplane bus 5 V DC, max.	100 mA	1 000 mA	350 mA	600 mA
Power losses				
Power loss, typ.	2 W	4.9 W	1.8 W	3.5 W
Analog inputs				
Number of analog inputs	16	8	8	8
Number of analog inputs for voltage/current measurement	16	8	8	8
Number of analog inputs for resistance measurement		4	4	4
permissible input voltage for voltage input (destruction limit), max.	20 V; 20 V DC permanent, 75 V DC for max. 1 s (duty factor 1:20)	18 V; 18 V continuous, 75 V for 1 ms (mark to space ratio 1:20)	50 V	18 V; 18 V continuous, 75 V for 1 ms (mark to space ratio 1:20)
permissible input current for current input (destruction limit), max.	40 mA	40 mA; Permanent	50 mA; 40 mA continuous	40 mA; Permanent
Input ranges (rated values), voltages				
• 1 to 5 V	Yes	Yes	Yes	Yes
• -1 V to +1 V	Yes	Yes	Yes	Yes
• -10 V to +10 V	Yes	Yes	Yes	Yes
• -2.5 V to +2.5 V				Yes
• -250 mV to +250 mV				Yes
• -5 V to +5 V				Yes
• -500 mV to +500 mV				Yes
• -80 mV to +80 mV				Yes

Technical specifications (continued)

	6ES7 431-0HH00-0AB0	6ES7 431-1KF20-0AB0	6ES7 431-1KF00-0AB0	6ES7 431-1KF10-0AB0
Input ranges (rated values), currents • 0 to 20 mA • -20 to +20 mA • 4 to 20 mA	Yes Yes	Yes Yes	Yes Yes	Yes Yes
Input ranges (rated values), thermoelements • Type B • Type E • Type J • Type K • Type L • Type N • Type R • Type S • Type T • Type U				Yes Yes Yes Yes Yes Yes Yes Yes Yes
Input ranges (rated values), resistance thermometers • Ni 100 • Ni 1000 • Pt 100 • Pt 1000 • Pt 10000 • Pt 200 • Pt 500				Yes Yes Yes Yes Yes Yes Yes
Input ranges (rated values), resistors • 0 to 150 ohms • 0 to 300 ohms • 0 to 48 ohms • 0 to 600 ohms • 0 to 6000 ohms		Yes	Yes	Yes Yes Yes Yes Yes; Usable up to 5000 Ohm
Thermocouple (TC) • for thermocouples • Temperature compensation - internal temperature compensation - external temperature compensation with compensations socket - external temperature compensation with Pt100 - dynamic reference temperature value				Type B, E, J, K, L, N, R, S, T, U No Yes Yes Yes
Resistance thermometer (RTD) • Characteristic linearization - for resistance thermometer				Pt100, Pt200, Pt500, Pt1000, Ni100, Ni1000
Characteristic linearization • Parameterizable				Yes
Cable length • Cable length, shielded, max.	200 m	200 m	200 m	200 m; 50 m with thermocouples and input ranges <= 80 mV

SIMATIC S7-400

Analog modules

SM 431 analog input module

Technical specifications (continued)

	6ES7 431-0HH00-0AB0	6ES7 431-1KF20-0AB0	6ES7 431-1KF00-0AB0	6ES7 431-1KF10-0AB0
Analog value creation				
Integrations and conversion time/ resolution per channel				
• Resolution with overrange (bit including sign), max.	13 bit	14 bit; 14 / 14 / 14	13 bit	14 bit; with activated filtering: 16 bits
• Integration time, parameterizable	Yes	Yes	Yes	Yes
• Basic conversion time, ms	55 / 65 ms	52 µs	23 / 25 ms	20.1 / 23.5 ms
• Integration time, ms	50 / 60 ms		16.7 / 20 ms	16.7 / 20 ms
• Basic conversion time, including integration time, ms				
- additional conversion time for wire break monitoring				4.3 ms
- additional conversion time for resistance measurement				40.2 / 47 ms
- additional conversion time for wire break monitoring and resistance measurement				5.5 ms
• Interference voltage suppression for interference frequency f1 in Hz	60 / 50 Hz	none / 400 / 60 / 50 Hz	60 / 50 Hz	60 / 50 Hz
Encoder				
Connection of signal encoders				
• for current measurement as 2-wire transducer		Yes	Yes; with external transmitter supply	Yes
• for current measurement as 4-wire transducer	Yes	Yes	Yes	Yes
• for resistance measurement with 2-conductor connection		Yes; Line resistances are also measured	Yes; Line resistances are also measured	Yes; Line resistances are also measured
• for resistance measurement with 3-conductor connection		Yes; Line resistances are also measured	Yes; Line resistances are also measured	Yes
• for resistance measurement with 4-conductor connection		Yes	Yes	Yes
Errors/accuracies				
Operational limit in overall temperature range				
• Voltage, relative to input area	+/- 0,65 %; 1.0% at 1 to 5 V; 0.65% at +/-1 V, +/-10 V	+/- 0,7 %; +/-0.7% at +/-1 V; +/-0.9% at +/-10 V, 1 to 5 V	+/- 1 %; +/-1.0% at +/-1 V; +/-0.6% at +/-10 V; +/-0.7% at 1 to 5 V	+/- 0,38 %; +/-0.38% at +/-80 mV; +/-0.35% at +/-250 mV, +/-500mV, +/-1 V, +/-2.5 V, +/-5 V, 1 to 5 V, +/-10 V
• Current, relative to input area	+/- 0,65 %	+/- 0,8 %; at +/-20 mA, 4 to 20 mA	+/- 1 %; at +/-20 mA, 4 to 20 mA	+/- 0,35 %; +/-20 mA, 0 to 20 mA, 4 to 20 mA
• Impedance, relative to input area		+/- 1 %	+/- 1,25 %; 0 to 500 ohms (4-conductor measurement, in range of 600 ohms)	+/- 0,5 %
• Resistance-type thermometer, relative to input area				+/- 0,5 %

Technical specifications (continued)

	6ES7 431-0HH00-0AB0	6ES7 431-1KF20-0AB0	6ES7 431-1KF00-0AB0	6ES7 431-1KF10-0AB0
Basic error limit (operational limit at 25 °C) <ul style="list-style-type: none"> • Voltage, relative to input area • Current, relative to input area • Impedance, relative to input area • Resistance-type thermometer, relative to input area 	+/- 0,25 %; 0.5% at 1 to 5 V; 0.25% at +/-1 V, +/-10 V	+/- 0,6 %; 0.6% at +/-1 V; 0.75% at +/-10 V, 1 to 5 V	+/- 0,7 %; 0.7% at +/-1 V; 0.4% at +/-10 V; 0.5% at 1 to 5 V	+/- 0,15 %; +/-0.15%(+/-250 mV, +/-500 mV, +/-1 V, +/-2.5 V, +/-5 V, 1 to 5 V, +/- 10 V); +/-0.17% (+/- 80 mV); +/- 0,15 %; +/-20 mA, 0 to 20 mA, 4 to 20 mA +/- 0,15 %; +/-0.15% at 0 to 48 ohms (4-conductor mea- surement), 0 to 150 ohms (4-conductor measure- ment), 0 to 300 ohms (4-conductor measure- ment), 0 to 600 ohms (4-conductor measure- ment), 0 to 5000 ohms (4-conductor measurement, in range of 6000 ohms); +/-0.3% at 0 to 300 ohms (3-conductor measure- ment), 0 to 600 ohms (3-conductor measure- ment), 0 to 5000 ohms (3-conductor measurement, in range of 6000 ohms) +/- 0,3 %
Galvanic isolation Galvanic isolation analog inputs <ul style="list-style-type: none"> • Galvanic isolation analog inputs • between the channels 	No No	Yes; internal/external No	Yes; internal/external No	Yes; internal/external No
Permissible potential difference between the inputs (UCM)	2 V DC / 2 Vpp AC	8 V AC	30 V AC	120 V AC
Isolation Isolation checked with	500 V DC between bus and local ground	2120 V DC between bus and analog part; 500 V DC between bus and local ground; 707 V DC between analog part and L+/M; 2120 V DC between analog part and local ground; 2120 V DC between L+/M and local ground	2120 V DC between bus and analog part; 500 V DC between bus and local ground; 2120 V DC between analog part and local ground	2120 V DC between bus and L+/M; 2120 V DC between bus and analog part; 500 V DC between bus and local ground; 707 V DC between analog part and L+/M; 2120 V DC between analog part and local ground; 2120 V DC between L+/M and local ground
Dimensions Width	25 mm	25 mm	25 mm	25 mm
Height	290 mm	290 mm	290 mm	290 mm
Depth	210 mm	210 mm	210 mm	210 mm
Required slots	1	1	1	1
Weight Weight, approx.	500 g	500 g	500 g	500 g

SIMATIC S7-400

Analog modules

SM 431 analog input module

Technical specifications (continued)

	6ES7 431-7QH00-0AB0	6ES7 431-7KF00-0AB0	6ES7 431-7KF10-0AB0
Supply voltage			
Load voltage L+			
• Rated value (DC)	24 V; Only required for supplying 2-wire transmitters		
• Reverse polarity protection	Yes		
Input current			
from load voltage L+ (without load), max.	400 mA	400 mA	400 mA
from backplane bus 5 V DC, max.	700 mA	1 200 mA	650 mA
Power losses			
Power loss, typ.	4.5 W	4.6 W	3.3 W
Analog inputs			
Number of analog inputs	16	8	8
Number of analog inputs for voltage/current measurement	16	8	
Number of analog inputs for resistance measurement	8		8
permissible input voltage for voltage input (destruction limit), max.	18 V; 18 V continuous, 75 V for 1 ms (mark to space ratio 1:20)	35 V; 35 V continuous, 75 V for max. 1 s (mark to space ratio 1:20)	35 V; 35 V continuous, 75 V for max. 1 s (mark to space ratio 1:20)
permissible input current for current input (destruction limit), max.	40 mA	32 mA	
Input ranges (rated values), voltages			
• 1 to 5 V	Yes	Yes	
• -1 V to +1 V	Yes	Yes	
• -10 V to +10 V	Yes	Yes	
• -100 mV to +100 mV		Yes	
• -2.5 V to +2.5 V	Yes	Yes	
• -20 mV to +20 mV		Yes	
• -25 mV to +25 mV	Yes		
• -250 mV to +250 mV	Yes	Yes	
• -5 V to +5 V	Yes	Yes	
• -50 mV to +50 mV	Yes	Yes	
• -500 mV to +500 mV	Yes	Yes	
• -80 mV to +80 mV	Yes	Yes	
Input ranges (rated values), currents			
• 0 to 20 mA	Yes	Yes	
• -10 to +10 mA	Yes	Yes	
• -20 to +20 mA	Yes	Yes	
• -3.2 to +3.2 mA		Yes	
• 4 to 20 mA	Yes	Yes	
• -5 to +5 mA	Yes	Yes	
Input ranges (rated values), thermoelements			
• Type B	Yes	Yes	
• Type E	Yes	Yes	
• Type J	Yes	Yes	
• Type K	Yes	Yes	
• Type L	Yes	Yes	
• Type N	Yes	Yes	
• Type R	Yes	Yes	
• Type S	Yes	Yes	
• Type T	Yes	Yes	
• Type U	Yes	Yes	

Technical specifications (continued)

	6ES7 431-7QH00-0AB0	6ES7 431-7KF00-0AB0	6ES7 431-7KF10-0AB0
Input ranges (rated values), resistance thermometers <ul style="list-style-type: none"> • Ni 100 • Ni 1000 • Pt 100 • Pt 1000 • Pt 200 • Pt 500 	Yes Yes Yes Yes Yes Yes		Yes Yes; Different characteristics selectable: Europe/U.S. Yes Yes Yes Yes
Input ranges (rated values), resistors <ul style="list-style-type: none"> • 0 to 150 ohms • 0 to 300 ohms • 0 to 48 ohms • 0 to 600 ohms • 0 to 6000 ohms 	Yes Yes Yes Yes Yes; Usable up to 5000 Ohm		
Thermocouple (TC) <ul style="list-style-type: none"> • for thermocouples • Temperature compensation <ul style="list-style-type: none"> - internal temperature compensation - external temperature compensation with compensations socket - external temperature compensation with Pt100 - dynamic reference temperature value 	Type B, E, J, K, L, N, R, S, T, U Yes Yes Yes	Type B, E, J, K, L, N, R, S, T, U Yes Yes Yes	
Resistance thermometer (RTD) <ul style="list-style-type: none"> • Characteristic linearization <ul style="list-style-type: none"> - for resistance thermometer 	Pt100, Pt200, Pt500, Pt1000, Ni100, Ni1000		Pt100, Pt200, Pt500, Pt1000, Ni100, Ni1000; different characteristics selectable (Europe/U.S.)
Characteristic linearization <ul style="list-style-type: none"> • Parameterizable 	Yes	Yes	Yes
Cable length <ul style="list-style-type: none"> • Cable length, shielded, max. 	200 m; 50 m with thermocouples and input ranges <= 80 mV	200 m	200 m; 50 m with thermocouples and input ranges +/-80 mV
Analog value creation			
Integrations and conversion time/ resolution per channel <ul style="list-style-type: none"> • Resolution with overrange (bit including sign), max. • Integration time, parameterizable • Basic conversion time, ms • Integration time, ms • Basic conversion time, including integration time, ms <ul style="list-style-type: none"> - additional conversion time for wire break monitoring - additional conversion time for resistance measurement - additional conversion time for wire break monitoring and resistance measurement • Interference voltage suppression for interference frequency f1 in Hz 	16 bit; 16 / 16 / 16 Yes 6 / 20.1 / 23.5 ms 2.5 / 16.7 / 20 ms 4.3 / 4.3 / 4.3 ms 12 / 40.2 / 47 ms 5.5 ms 400 / 60 / 50 Hz	16 bit Yes 10 / 16.7 / 20 / 100 2.5 / 16.7 / 20 / 100 ms 1 ms (module) 400 / 60 / 50 / 10 Hz	16 bit Yes 8 / 23 / 25 ms 20 ms at 50 Hz (entire module incl. wire break) 110 ms / 4 ms none none/ 60 / 50 Hz

SIMATIC S7-400

Analog modules

SM 431 analog input module

Technical specifications (continued)

	6ES7 431-7QH00-0AB0	6ES7 431-7KF00-0AB0	6ES7 431-7KF10-0AB0
Encoder			
Connection of signal encoders			
• for current measurement as 2-wire transducer	Yes		
• for current measurement as 4-wire transducer	Yes	Yes	
• for resistance measurement with 2-conductor connection	Yes; Line resistances are also measured		
• for resistance measurement with 3-conductor connection	Yes		Yes
• for resistance measurement with 4-conductor connection	Yes	Yes	Yes
Errors/accuracies			
Operational limit in overall temperature range			
• Voltage, relative to input area	+/- 0,3 %; +/-0.3% at +/-250 mV, +/-500 mV, +/-1 V, +/-2.5 V, +/-5 V, 1 to 5 V, +/- 10 V; +/-0.31% at +/-80 mV; +/-0.32% at +/-50 mV; +/-0.35% at +/-25 mV;	+/- 0,3 %	
• Current, relative to input area	+/- 0,3 %; at 0 to 20 mA, +/-5 mA, +/-10 mA, +/- 20 mA, 4 to 20 mA	+/- 0,5 %	
• Impedance, relative to input area	+/- 0,3 %; +/-0.3% at 0 to 48 Ohm (4-conductor measurement), 0 to 150 Ohm (4-conductor mea- surement), 0 to 300 Ohm (4-conduc- tor measurement), 0 to 600 Ohm (4-conductor measurement), 0 to 5000 Ohm (4-conductor mea- surement, in range of 6000 Ohm); +/-0.4% at 0 to 300 Ohm (3-conduc- tor measurement), 0 to 600 Ohm (3-conductor measurement), 0 to 5000 Ohm (3-conductor mea- surement, in range of 6000 Ohm);		
• Resistance-type thermometer, relative to input area	+/- 0,4 %		+/-1 °C
Basic error limit (operational limit at 25 °C)			
• Voltage, relative to input area	+/- 0,15 %; +/-0.15% at +/-250 mV, +/-500 mV, +/-1 V, +/-2.5 V, +/-5 V, 1 to 5 V, +/-10 V; +/-0.17% at +/-80 mV; +/-0.19% at +/-50 mV; +/-0.23% at +/-25 mV;	+/- 0,1 %	
• Current, relative to input area	+/- 0,15 %; at 0 to 20 mA, +/-5 mA, +/-10 mA, +/- 20 mA, 4 to 20 mA	+/- 0,17 %	
• Impedance, relative to input area	+/- 0,15 %; +/-0.15% at 0 to 48 ohms (4-conductor measurement), 0 to 150 ohms (4-conductor mea- surement), 0 to 300 ohms (4-conduc- tor measurement), 0 to 5000 ohms (4-conductor measurement, in range of 6000 ohms); +/-0.3% at 0 to 300 ohms (3-conductor measurement), 0 to 600 ohms (3-conductor measurement), 0 to 5000 ohms (3-conductor measurement, in range of 6000 ohms)		
• Resistance-type thermometer, relative to input area	+/- 0,3 %		+/-0.2 °C

Technical specifications (continued)

	6ES7 431-7QH00-0AB0	6ES7 431-7KF00-0AB0	6ES7 431-7KF10-0AB0
Interrupts/diagnostics/ status information			
Alarms			
• Diagnostic alarm	Yes; Parameterizable	Yes; Parameterizable	Yes; Parameterizable
• Limit value alarm	Yes; Parameterizable	Yes	Yes
Diagnostic messages			
• Diagnostics	Yes; Parameterizable	Yes	Yes
Galvanic isolation			
Galvanic isolation analog inputs			
• Galvanic isolation analog inputs	Yes; internal/external	Yes; internal/external	Yes; internal/external
• between the channels	No	Yes	No
Permissible potential difference between the inputs (UCM)	120 V AC	120 V AC	none
Isolation			
Isolation checked with	2120 V DC between bus and L+/M; 2120 V DC between bus and analog part; 500 V DC between bus and local ground; 707 V DC between analog part and L+/M; 2120 V DC between analog part and local ground; 2120 V DC between L+/M and local ground	1500 V DC	1500 V DC
Dimensions			
Width	25 mm	25 mm	25 mm
Height	290 mm	290 mm	290 mm
Depth	210 mm	210 mm	210 mm
Required slots	1	1	1
Weight			
Weight, approx.	500 g	650 g	650 g

SIMATIC S7-400

Analog modules

SM 431 analog input module

Ordering data

SM 431 analog input modules

16 inputs, non-isolated, 13 bit

6ES7 431-0HH00-0AB0

8 inputs, isolated, 13 bit

6ES7 431-1KF00-0AB0

8 inputs, isolated, 14 bit,
with linearization

6ES7 431-1KF10-0AB0

8 inputs, isolated, 14 bit

6ES7 431-1KF20-0AB0

16 inputs, isolated, 16 bit,
process interrupt capability

6ES7 431-7QH00-0AB0

8 inputs, isolated, 16 bit,
process interrupt capability,
for thermocouples (I, U)

6ES7 431-7KF00-0AB0

8 inputs, isolated, 16 bit,
process interrupt capability,
for thermal resistors

6ES7 431-7KF10-0AB0

Front connector

48-pin

- with screw contacts, 1 unit
- with screw contacts, 84 units
- with spring-loaded terminals, 1 unit
- with crimp contacts, 1 unit
- with crimp contacts, 84 units

6ES7 492-1AL00-0AA0

6ES7 492-1AL00-1AB0

6ES7 492-1BL00-0AA0

6ES7 492-1CL00-0AA0

6ES7 492-1CL00-1AB0

1 unit; for 6ES7 431-7KF00-0AB0;
spare part, included in scope of
delivery

6ES7431-7KF00-6AA0

SIMATIC TOP connect

See page 6/129

Measuring range module for analog inputs

6ES7 974-0AA00-0AA0

1 module for 2 inputs (spare part)

Order No.

Cover film for labeling strips

6ES7 492-2XX00-0AA0

Spare part

Labeling sheets for machine inscription

DIN A4, for printing using laser
printer; pack of 10

petrol

6ES7 492-2AX00-0AA0

light-beige

6ES7 492-2BX00-0AA0

yellow

6ES7 492-2CX00-0AA0

red

6ES7 492-2DX00-0AA0

SIMATIC Manual Collection

6ES7 998-8XC01-8YE0

Electronic manuals on DVD,
multilingual: LOGO!, SIMADYN,
SIMATIC bus components,
SIMATIC C7, SIMATIC distributed I/O,
SIMATIC HMI, SIMATIC Sensors,
SIMATIC NET, SIMATIC PC Based
Automation, SIMATIC PCS 7,
SIMATIC PG/PC, SIMATIC S7,
SIMATIC Software, SIMATIC TDC

SIMATIC Manual Collection update service for 1 year

6ES7 998-8XC01-8YE2

Current "Manual Collection" DVD
and the three subsequent updates

Overview



- Analog outputs for the SIMATIC S7-400
- For the connection of analog actuators

Technical specifications

6ES7 432-1HF00-0AB0	
Supply voltage	
Load voltage L+	
• Rated value (DC)	24 V
Input current	
from backplane bus 5 V DC, max.	150 mA
from supply voltage L+, max.	400 mA
Power losses	
Power loss, max.	9 W
Analog outputs	
Number of analog outputs	8
Voltage output, short-circuit protection	Yes
Voltage output, short-circuit current, max.	30 mA
Current output, no-load voltage, max.	19 V
Output ranges, voltage	
• 0 to 10 V	Yes
• 1 to 5 V	Yes
• -10 to +10 V	Yes
Output ranges, current	
• 0 to 20 mA	Yes
• -20 to +20 mA	Yes
• 4 to 20 mA	Yes
Load impedance (in rated range of output)	
• with voltage outputs, min.	1 k Ω
• with voltage outputs, capacitive load, max.	1 μ F
• with current outputs, max.	500 Ω ; 600 ohms if common-mode-voltage reduced to <1 V
Cable length	
• Cable length, shielded, max.	200 m
Analog value creation	
Integrations and conversion time/ resolution per channel	
• Resolution with overrange (bit including sign), max.	13 bit
• Conversion time (per channel)	420 μ s; 420 μ s in the ranges 1 to 5 V and 4 to 20 mA; 300 μ s in all ranges

6ES7 432-1HF00-0AB0	
Settling time	
• for resistive load	0.1 ms
• for capacitive load	3.5 ms
• for inductive load	0.5 ms
Errors/accuracies	
Operational limit in overall temperature range	
• Voltage, relative to output area	+/- 0,5 %; +/-10 V, 0 to 10 V, 1 to 5 V
• Current, relative to output area	+/- 1 %; +/-20 mA, 4 to 20 mV
Basic error limit (operational limit at 25 °C)	
• Voltage, relative to output area	+/- 0,5 %; +/-10 V, 0 to 10 V, 1 to 5 V
• Current, relative to output area	+/- 0,5 %; +/-20 mA, 0 to 20 mA
Interrupts/diagnostics/ status information	
Substitute values connectable	No
Galvanic isolation	
Galvanic isolation analog outputs	
• between the channels and the backplane bus	Yes
Isolation	
Isolation checked with	
	2120 V DC between bus and L+/M; 2120 V DC between bus and analog part; 500 V DC between bus and local ground; 707 V DC between analog part and L+/M; 2120 V DC between analog part and local ground; 2120 V DC between L+/M and local ground
Dimensions	
Width	25 mm
Height	290 mm
Depth	210 mm
Required slots	1
Weight	
Weight, approx.	650 g

SIMATIC S7-400

Analog modules

SM 432 analog output module

Ordering data	Order No.		Order No.
SM 432 analog output module 8 outputs, isolated, 13 bit	6ES7 432-1HF00-0AB0	Labeling sheets for machine inscription	
Front connector 48-pin		DIN A4, for printing using laser printer; pack of 10	
• with screw contacts, 1 unit	6ES7 492-1AL00-0AA0	petrol	6ES7 492-2AX00-0AA0
• with screw contacts, 84 units	6ES7 492-1AL00-1AB0	light-beige	6ES7 492-2BX00-0AA0
• with spring-loaded terminals, 1 unit	6ES7 492-1BL00-0AA0	yellow	6ES7 492-2CX00-0AA0
• with crimp contacts, 1 unit	6ES7 492-1CL00-0AA0	red	6ES7 492-2DX00-0AA0
• with crimp contacts, 84 units	6ES7 492-1CL00-1AB0		
SIMATIC TOP connect	See page, page 6/129	SIMATIC Manual Collection	6ES7 998-8XC01-8YE0
Cover film for labeling strips Spare part	6ES7 492-2XX00-0AA0	Electronic manuals on DVD, multilingual: LOGO!, SIMADYN, SIMATIC bus components, SIMATIC C7, SIMATIC distributed I/O, SIMATIC HMI, SIMATIC Sensors, SIMATIC NET, SIMATIC PC Based Automation, SIMATIC PCS 7, SIMATIC PG/PC, SIMATIC S7, SIMATIC Software, SIMATIC TDC	
		SIMATIC Manual Collection update service for 1 year	6ES7 998-8XC01-8YE2
		Current "Manual Collection" DVD and the three subsequent updates	

SIMATIC S7-400

SIPLUS analog modules

SIPLUS SM 431 analog input module

Overview



- Analog inputs for SIMATIC S7-400
- For connecting voltage sensors and current sensors, thermocouples, resistors and resistance thermometers
- Resolution 13 to 16 bit

Note:

SIPLUS extreme products are based on Siemens Industry standard products. The contents listed here were taken from the respective standard products. SIPLUS extreme specific information was added.

SIPLUS SM 431 analog input module

Order number	6AG1 431-0HH00-4AB0
Order No. based on	6ES7 431-0HH00-0AB0
Ambient temperature range	0 ... +60 °C
Conformal coating	Coating of the printed circuit boards and the electronic components
Technical data	The technical data of the standard product applies, except for the ambient conditions
Ambient conditions	
Relative humidity	100%, condensation/frost permissible. No commissioning if condensation present.
Biologically active substances, compliance with EN 60721-3-3	Class 3B2 mold and fungal spores (excluding fauna). The supplied plug covers must remain in place over the unused interfaces during operation!
Chemically active substances, compliance with EN 60721-3-3	Class 3C4 incl. salt spray in accordance with EN60068-2-52 (degree of severity 3). The supplied plug covers must remain in place over the unused interfaces during operation!
Mechanically active substances, compliance with EN 60721-3-3	Class 3S4 incl. sand, dust. The supplied plug covers must remain in place over the unused interfaces during operation!
Air pressure (depending on the highest positive temperature range specified)	1080 ... 795 hPa (-1000 ... +2000 m) see ambient temperature range 795 ... 658 hPa (+2000 ... +3500 m) derating 10 K 658 ... 540 hPa (+3500 ... +5000 m) derating 20 K

For technical documentation on SIPLUS, see:
www.siemens.com/siplus-extreme

Ordering data	Order No.
SIPLUS SM 431 analog input module (medial exposure) 16 inputs, non-floating, 13 bit	6AG1 431-0HH00-4AB0
Accessories	See SIMATIC S7-400 analog input modules, page 6/72

SIMATIC S7-400

SIPLUS analog modules

SIPLUS SM 432 analog output module

Overview



- Analog outputs for SIMATIC S7-400
- For connection of analog actuators

Note:

SIPLUS extreme products are based on Siemens Industry standard products. The contents listed here were taken from the respective standard products. SIPLUS extreme specific information was added.

SIPLUS SM 432 analog output module

Order number	6AG1 432-1HF00-4AB0
Order No. based on	6ES7 432-1HF00-0AB0
Range of ambient temperature	0 ... +60 °C
Conformal coating	Coating of the printed circuit boards and the electronic components
Technical data	The technical data of the standard product applies except for the environmental conditions.
Ambient conditions	
Relative humidity	100%, condensation/frost permissible. No commissioning if condensation present.
Biologically active substances, compliance with EN 60721-3-3	Class 3B2 mold and fungal spores (excluding fauna). The supplied plug covers must remain in place over the unused interfaces during operation!
Chemically active substances, compliance with EN 60721-3-3	Class 3C4 incl. salt spray in accordance with EN60068-2-52 (degree of severity 3). The supplied plug covers must remain in place over the unused interfaces during operation!
Mechanically active substances, compliance with EN 60721-3-3	Class 3S4 incl. sand, dust. The supplied plug covers must remain in place over the unused interfaces during operation!
Air pressure (depending on the highest positive temperature range specified)	1080 ... 795 hPa (-1000 ... +2000 m) see ambient temperature range 795 ... 658 hPa (+2000 ... +3500 m) derating 10 K 658 ... 540 hPa (+3500 ... +5000 m) derating 20 K

For technical documentation on SIPLUS, see:
www.siemens.com/siplus-extreme

Ordering data	Order No.
SIPLUS SM 432 analog output module	6AG1 432-1HF00-4AB0
(medial exposure)	
8 outputs, floating, 13 bit	
Accessories	See SIMATIC S7-400 analog output modules, page 6/74

Overview



- Two-channel intelligent counter module for simple counting tasks
- For direct connection of incremental encoders
- Comparison function with 2 specifiable comparison values
- Integrated digital outputs for outputting the response when the comparison values are reached

Note

SIMODRIVE Sensor/Motion Connect 500 feature incremental encoders and preassembled connecting cables for counting and positioning functions.

www.siemens.com/simatic-technology

Technical specifications

6ES7 450-1AP00-0AE0	
Supply voltage	
Load voltage 1L+	
• Reverse polarity protection	Yes
Load voltage 2L+	
• Reverse polarity protection	Yes
Aux. voltage 1L+, load voltage 2 L+	
• Rated value (DC)	24 V
• permissible range, lower limit (DC)	20.4 V; Dynamic 18.5 V
• permissible range, upper limit (DC)	28.8 V; dynamic 30.2 V
• non-periodic skip	
- Duration	500 ms
- Recovery time	50 s
- Value	35 V
Input current	
from load voltage 1L+ (without load), max.	40 mA
from backplane bus 5 V DC, max.	450 mA
Encoder supply	
5 V encoder supply	
• 5 V	Yes; 5.2 V +/-2%
• Short-circuit protection	Yes
• Output current, max.	300 mA
24 V encoder supply	
• 24 V	Yes; 1L+ (-3 V)
• Short-circuit protection	Yes
• Output current, max.	300 mA
Power losses	
Power loss, typ.	9 W

6ES7 450-1AP00-0AE0	
Digital inputs	
Number/binary inputs	6
Functions	1 for gate start, 1 for gate stop, 1 for setting the counter
Input voltage	
• for signal "0"	-28.8 to +5 V
• for signal "1"	+11 to +28.8 V
Input current	
• for signal "1", typ.	9 mA
Input delay (for rated value of input voltage)	
• Input frequency (with a time delay of 0.1 ms), max.	200 kHz
• for standard inputs	
- Parameterizable	Yes
- at "0" to "1", max.	2.5 µs; >= 2.5 µs (200 kHz); <= 25 µs (20 kHz)
Digital outputs	
Number/binary outputs	6
Functionality/short-circuit strength	Yes; Clocked electronically
Limitation of inductive shutdown voltage to	2L+ (-39 V)
Output voltage	
• for signal "0", max.	3 V
• for signal "1", min.	2L+ (-1.5 V)
Output current	
• for signal "1" rated value	0.5 A
• for signal "1" permissible range for 0 to 60 °C, min.	5 mA
• for signal "1" permissible range for 0 to 60 °C, max.	0.6 A
Output delay with resistive load	
• "0" to "1", max.	300 µs

SIMATIC S7-400

Function modules

FM 450-1 counter module

Technical specifications (continued)

6ES7 450-1AP00-0AE0	
Encoder	
Connectable encoders	
• Incremental encoder (symmetrical)	Yes; With 2 pulse trains offset by 90°
• Incremental encoder (asymmetrical)	Yes
• 24 V initiator	Yes
• 24 V directional element	Yes; 1 pulse train, 1 direction level
Counter	
Number of counter inputs	2; 32 bit or +/-31 bit
Counter input 5 V	
• Type	RS 422
• Terminating resistor	220 Ω
• Differential input voltage	min. 0.5 V
• Counting frequency, max.	500 kHz
Counter input 24 V	
• Input voltage, for signal "0"	-30 to +5 V
• Input voltage, for signal "1"	+11 to +30 V
• Input current, for signal "1", typ.	9 mA
• Counting frequency, max.	200 kHz
• Minimum pulse width	>= 2.5 μs (200 kHz); <= 25 μs (20 kHz) (parameterizable)
Parameter	
Remark	Assigned binary addresses: 64 bytes/64 bytes
Galvanic isolation	
Galvanic isolation digital inputs	
• between the channels and the backplane bus	Yes; Optocoupler
Galvanic isolation digital outputs	
• between the channels and the backplane bus	Yes; Optocoupler
Galvanic isolation counter	
• between the channels and the backplane bus	Yes; Optocoupler
Permissible potential difference	
between different circuits	75 VDC / 60 VAC
Isolation	
Isolation checked with	500 V
Connection method	
required front connector	1x 48-pin
Dimensions	
Width	25 mm
Height	290 mm
Depth	210 mm
Weight	
Weight, approx.	650 g

Ordering data

Order No.

FM 450-1 counter module	6ES7 450-1AP00-0AE0
with 2 channels, max. 500 kHz; for incremental encoder	
Front connectors	
48-pin	
• with screw contacts, 1 item	6ES7 492-1AL00-0AA0
• with screw contacts, 84 items	6ES7 492-1AL00-1AB0
• with spring-loaded terminals, 1 item	6ES7 492-1BL00-0AA0
• with crimp contacts, 1 item	6ES7 492-1CL00-0AA0
• with crimp contacts, 84 items	6ES7 492-1CL00-1AB0
Front covers for CPU and function modules	
Spare part	6ES7 492-1XL00-0AA0

SIMATIC S7-400

Function modules

FM 451 positioning module

Overview



- Three-channel positioning module for rapid/slow-action drives
- 4 digital outputs per channel for motor control
- Displacement measurement incremental or synchronous-serial

Note

Displacement measuring systems and precut/preassembled cables for counting and positioning functions are available under SIMODRIVE Sensor or Motion Connect 500.

www.siemens.com/simatic-technology

Technical specifications

6ES7 451-3AL00-0AE0	
Supply voltage 24 V DC	Yes
Input current Current consumption, max.	550 mA
Encoder supply 5 V encoder supply	
• 5 V	Yes
• Output current, max.	210 mA
• Cable length, max.	35 m; at max. 210 mA
24 V encoder supply	
• 24 V	Yes
• Output current, max.	300 mA
• Cable length, max.	100 m; at max. 300 mA
Absolute encoder (SSI) encoder supply	
• Absolute encoder (SSI)	Yes
• Output voltage	24 V DC
• Output current, max.	300 mA
• Cable length, max.	300 m; At max. 156 kbit/s
Digital inputs Number/binary inputs	12; 4 per axis
Functions	Reference cams, reversing cams, flying actual value setting, start/stop positioning
Input voltage	
• Rated value, DC	24 V
• for signal "0"	-3 to +5 V
• for signal "1"	11 to 30 V
Input current	
• for signal "1", typ.	6 mA
• for 2-wire sensor - for signal "1", typ.	30 mA

6ES7 451-3AL00-0AE0	
Digital outputs Number/binary outputs	12; 4 per axis
Functions	Rapid traverse, creep, run right, run left
Functionality/short-circuit strength	Yes
Output voltage	
• for signal "1", min.	UP -3 V
Output current	
• for signal "1" permissible range for 0 to 55 °C, max.	600 mA; with UPmax
• for signal "0" residual current, max.	0.5 mA
Encoder Connectable encoders	
• Incremental encoder (symmetrical)	Yes
• Incremental encoder (asymmetrical)	Yes
• Absolute encoder (SSI)	Yes
Encoder signals, incremental encoder (symmetrical)	
• Trace mark signals	A, notA, B, notB
• Zero mark signal	N, notN
• Input signal	5 V difference signal (phys. RS 422)
• Input frequency, max.	1 MHz
Encoder signals, incremental encoder (asymmetrical)	
• Trace mark signals	A, B
• Zero mark signal	N
• Input voltage	24 V
• Input frequency, max.	50 kHz; for 25 m cable length, 25 kHz for 100 m cable length
• Cable length, shielded, max.	100 m
Encoder signals, absolute encoder (SSI)	
• Input signal	5 V difference signal (phys. RS 422)
• Data signal	DATA, notDATA
• Clock signal	CL, notCL
• Message frame length, parameterizable	13 or 25 bit serial
• Clock frequency, max.	1.25 MHz
• Gray code	1
• Cable length, shielded, max.	300 m; At max. 156 kbit/s
Galvanic isolation Galvanic isolation digital inputs	
• Galvanic isolation digital inputs	Yes
Galvanic isolation digital outputs	
• Galvanic isolation digital outputs	Yes
Degree and class of protection IP20	Yes
Ambient conditions Operating temperature	
• Min.	0 °C
• max.	55 °C
Storage/transport temperature	
• Min.	-40 °C
• max.	70 °C
Relative humidity	
• Humidity class F	Yes
Connection method required front connector	1x 48-pin
Dimensions Width	50 mm
Height	290 mm
Depth	210 mm
Weight Weight, approx.	1 300 g

SIMATIC S7-400

Function modules

FM 451 positioning module

Ordering data

Order No.

FM 451 positioning module

6ES7 451-3AL00-0AE0

for rapid traverse and creep speed drives

Front connector

48-pin

- with screw contacts, 1 item
- with screw contacts, 84 items
- with spring-loaded terminals, 1 item
- with crimp contacts, 1 item
- with crimp contacts, 84 items

6ES7 492-1AL00-0AA0
 6ES7 492-1AL00-1AB0
 6ES7 492-1BL00-0AA0
 6ES7 492-1CL00-0AA0
 6ES7 492-1CL00-1AB0

Front covers for CPU and function modules

6ES7 492-1XL00-0AA0

Spare part

Signal cable

Pre-assembled for HTL encoder, UL/DESINA

6FX5 0 2-2AL00-

Pre-assembled for SSI absolute encoder, UL/DESINA

6FX5 0 2-2CC11-

Pre-assembled for TTL encoder 6FX2001-1, UL/DESINA

6FX5 0 2-2CD01-

Pre-assembled for TTL encoder 24 V, UL/DESINA

6FX5 0 2-2CD24-

Not crimped

0

Module end crimped, connector case supplied

1

Motor end crimped, connector case supplied

4

0 m

1

100 m

2

200 m

3

0 m

A

10 m

B

20 m

C

30 m

D

40 m

E

50 m

F

60 m

G

70 m

H

80 m

J

90 m

K

0 m

A

1 m

B

2 m

C

3 m

D

4 m

E

5 m

F

6 m

G

7 m

H

8 m

J

0 m

K

0.0 m

0

0.1 m

1

0.2 m

2

0.3 m

3

0.4 m

4

0.5 m

5

0.6 m

6

0.7 m

7

0.8 m

8

Overview



- Very high speed electronic cam controller
- Low-cost alternative to mechanical cam controllers
- 32 cam tracks, 16 onboard digital outputs for direct output of actions
- Incremental or synchronous-serial position feedback

Note:

We offer position measuring systems and preassembled connecting cables for counting and positioning functions under SIMODRIVE Sensor or Motion Connect 500.

www.siemens.com/simatic-technology

Technical specifications

6ES7 452-1AH00-0AE0	
Supply voltage 24 V DC	Yes
Input current Current consumption, max.	500 mA
Encoder supply 5 V encoder supply	Yes
• 5 V	Yes
• Output current, max.	300 mA
• Cable length, max.	32 m
24 V encoder supply	Yes
• 24 V	Yes
• Output current, max.	300 mA
• Cable length, max.	100 m
Digital inputs Number/binary inputs	11
Functions	Reference point switch, flying actual value setting/length measurement, brake release, enable track output no. 3 to 10
Input voltage	24 V
• Rated value, DC	-28.8 to +5 V
• for signal "0"	11 to 28.8 V
• for signal "1"	
Input current	2 mA
• for signal "0", max. (permissible quiescent current)	
• for 2-wire sensor	9 mA
- for signal "1", typ.	
Digital outputs Number/binary outputs	16
Functions	Cam track
Functionality/short-circuit strength	Yes
Output voltage	24 V
• Rated value (DC)	UP - 0.8 V
• for signal "1", min.	
Output current	600 mA; with UPmax
• for signal "1" permissible range for 0 to 55 °C, max.	
• for signal "0" residual current, max.	0.5 mA

6ES7 452-1AH00-0AE0	
Encoder Connectable encoders	
• Incremental encoder (symmetrical)	Yes
• Incremental encoder (asymmetrical)	Yes
• Absolute encoder (SSI)	Yes
• 2-wire sensor	Yes
Encoder signals, incremental encoder (symmetrical)	
• Trace mark signals	A, notA, B, notB
• Zero mark signal	N, notN
• Input signal	5 V difference signal (phys. RS 422)
• Input frequency, max.	1 MHz
Encoder signals, incremental encoder (asymmetrical)	
• Trace mark signals	A, B
• Zero mark signal	N
• Input voltage	24 V
• Input frequency, max.	50 kHz; 50 kHz for 25 m cable length; 25 kHz for 100 m cable length
Encoder signals, absolute encoder (SSI)	
• Input signal	5 V difference signal (phys. RS 422)
• Data signal	DATA, notDATA
• Clock signal	CL, notCL
• Message frame length, parameterizable	13 or 25 bit serial
• Clock frequency, max.	1 MHz
• Gray code	1
• Cable length, shielded, max.	300 m; at max. 125 kHz
Galvanic isolation Galvanic isolation digital inputs	No
• Galvanic isolation digital inputs	
Galvanic isolation digital outputs	No
• Galvanic isolation digital outputs	
Degree and class of protection IP20	Yes

SIMATIC S7-400

Function modules

FM 452 cam controller

Technical specifications (continued)

	6ES7 452-1AH00-0AE0
Ambient conditions	
Operating temperature	
• Min.	0 °C
• max.	55 °C
Storage/transport temperature	
• Min.	-40 °C
• max.	70 °C
Relative humidity	
• Humidity class F	Yes
Connection method	
required front connector	1x 48-pin
Dimensions	
Width	25 mm
Height	290 mm
Depth	210 mm
Weight	
Weight, approx.	650 g

Ordering data

Order No.

FM 452 electronic cam controller	6ES7 452-1AH00-0AE0
Front covers for CPU and function modules	6ES7 492-1XL00-0AA0
Spare part	
Front connector	
48-pin	
• with screw contacts, 1 item	6ES7 492-1AL00-0AA0
• with screw contacts, 84 items	6ES7 492-1AL00-1AB0
• with spring-loaded terminals, 1 item	6ES7 492-1BL00-0AA0
• with crimp contacts, 1 item	6ES7 492-1CL00-0AA0
• with crimp contacts, 84 items	6ES7 492-1CL00-1AB0
Signal cable	
Pre-assembled for HTL and TTL encoder, without Sub-D connector, UL/DESINA	6FX5 002-2CA12-■■■■■
Pre-assembled for SSI absolute encoder 6FX2001-5, without Sub-D connector, UL/DESINA	6FX5 002-2CC12-■■■■■
Length code	see FM 451, page 6/80

Overview



- Positioning module for servo and/or stepper motors in machines with high clock-pulse rates
- Can be used for simple point-to-point positioning and for complex traversing profiles
- Up to 3 independent motors can be controlled

Note:

We offer position measuring systems and preassembled connecting cables for counting and positioning functions under SIMODRIVE Sensor or Motion Connect 500.

Further information can be found on the Internet at:

www.siemens.com/simatic-technology

Technical specifications

6ES7 453-3AH00-0AE0	
Supply voltage	
Auxiliary voltage	24 V
• Rated value (DC)	18.5 to 30.2 V
• dynamic range	20.4 to 28.8 V
• static area	
Input current	
from load voltage 1L+, max.	1 A; with 24 V position encoder; 1 A for 5 V position encoder
from load voltage 2L+ to 4L+, max.	2 A; Per channel
from backplane bus 5 V DC, max.	1.6 A; Rated current
Encoder supply	
5 V encoder supply	Yes
• 5 V	
• Output current, max.	300 mA
• Cable length, max.	35 m; at max. 210 mA; 25 m at max. 300 mA
24 V encoder supply	Yes
• 24 V	
• Cable length, max.	100 m; at max. 300 mA
Power losses	
Power loss, max.	8 W
Digital inputs	
Number/binary inputs	6; for each channel/axis
Functions	configurable
Input voltage	
• Rated value, DC	24 V
• for signal "0"	-3 to +5 V (max. 3 mA)
• for signal "1"	11 to 30 V (max. 7 mA)
Input delay (for rated value of input voltage)	
• for standard inputs	
- at "0" to "1", max.	15 µs; via input voltage range, 8 µs at 24 V DC
- at "1" to "0", max.	45 µs; via input voltage range

6ES7 453-3AH00-0AE0	
Digital outputs	
Number/binary outputs	4; for each channel/axis
Functions	configurable
Functionality/short-circuit strength	Yes
Output voltage	
• Rated value (DC)	24 V
• for signal "1", min.	UP - 0,3 V
Output current	
• for signal "1" rated value	0.5 A; at 40 °C; 0.1 A at 60 °C
• for signal "1" permissible range for 0 to 40 °C, min.	5 mA
• for signal "1" permissible range for 0 to 40 °C, max.	0.6 A
• for signal "1" permissible range for 40 to 60 °C, min.	5 mA
• for signal "1" permissible range for 40 to 60 °C, max.	0.12 A
• for signal "0" residual current, max.	2 mA
Switching frequency	
• with resistive load, max.	100 Hz
• with inductive load, max.	0.25 Hz
Encoder	
Connectable encoders	
• Incremental encoder (symmetrical)	Yes
• Absolute encoder (SSI)	Yes
Encoder signals, incremental encoder (symmetrical)	
• Input signal	5 V difference signal (phys. RS 422)
• Input frequency, max.	1 MHz; for 10 m cable length; 0.5 MHz for 35 m cable length
Encoder signals, absolute encoder (SSI)	
• Input signal	5 V difference signal (phys. RS 422)
• Clock frequency, max.	1.25 Mbit/s at 10 cable length (2.5 Mbit/s available soon)
• Cable length, shielded, max.	250 m; At max. 156 kbit/s

SIMATIC S7-400

Function modules

FM 453 positioning module

Technical specifications (continued)

6ES7 453-3AH00-0AE0	
Drive interface	
Signal input I	
• Type	Drive interface step, signal input "READY 1"
• Function	"Power section ready" where $U_i < 1\text{ V}$, $I_i = 2\text{ mA}$
Signal output I	
• Type	5 V (phys. RS 422)
• Function	Clock pulse, direction, enable, current control
• Differential output voltage, min.	2 V; $R_L = 100\ \Omega$
• Differential output voltage for signal "0", max.	1.1 V; $I_o = 30\ \text{mA}$
• Differential output voltage, for signal "1", min.	3.7 V; $I_o = -30\ \text{mA}$
• Load impedance	55 Ω
• Pulse frequency	200 kHz; 500 kHz available soon
• Cable length, max.	35 m; 35 m with symm. transmission; 10 m with asymm. transmission
Signal output II	
• Type	Contact relay
• Function	Drive disconnection for operation
• Load	1 A/50 V/30 VA DC
Signal output III	
• Type	Analog output
• Function	Drive interface Servo: Setpoint output for drive
• Output voltage	-10 to +10 V
• Output current	-3 to +3 mA
• Cable length, max.	30 m
Galvanic isolation	
Galvanic isolation digital inputs	
• Galvanic isolation digital inputs	Yes; Optocoupler
Galvanic isolation digital outputs	
• Galvanic isolation digital outputs	Yes; Optocoupler
Degree and class of protection	
IP20	Yes
Ambient conditions	
Operating temperature	
• Min.	0 °C
• max.	55 °C
Storage/transport temperature	
• Min.	-40 °C
• max.	70 °C
Relative humidity	
• Humidity class F	No
Connection method	
required front connector	1x 48-pin
Dimensions	
Width	50 mm
Height	290 mm
Depth	210 mm
Weight	
Weight, approx.	1 620 g

Ordering data

Order No.

FM 453 positioning module	6ES7 453-3AH00-0AE0
with 3 channels/axes	
Setpoint connecting cable	
for 3 servo motors	6FX2 002-3AD01-■■■■■
for 3 stepper motors	6FX2002-3AB04-■■■■■
for 2 servo motors / 1 stepper motor	6FX2002-3AB02-■■■■■
for 1 servo motor / 2 stepper motors	6FX2002-3AB03-■■■■■
Length code	See page 6/80
Front connector	
48-pin	
• with screw contacts, 1 item	6ES7 492-1AL00-0AA0
• with screw contacts, 84 items	6ES7 492-1AL00-1AB0
• with spring-loaded terminals, 1 item	6ES7 492-1BL00-0AA0
• with crimp contacts, 1 item	6ES7 492-1CL00-0AA0
• with crimp contacts, 84 items	6ES7 492-1CL00-1AB0
Front covers for CPU and function modules	
Spare part	6ES7 492-1XL00-0AA0
Signal cable	
Pre-assembled for SSI absolute encoder, UL/DESINA	6FX5 0■■2-2CC11-■■■■■
Pre-assembled for TTL encoder 6FX2001-1, UL/DESINA	6FX5 0■■2-2CD01-■■■■■
Pre-assembled for TTL encoder 24 V, UL/DESINA	6FX5 0■■2-2CD24-■■■■■
Length code	See page 6/80

Overview



- 16-channel closed-loop control module for universal control tasks
- Can be used for temperature, pressure and flow controls
- Convenient online self-optimization for temperature controls
- Predefined controller structures
- 2 control algorithms
- 2 versions:
 - FM 455 C as continuous controller
 - FM 455 S as step or pulse controller
- With 16 analog outputs (FM 455 C) or 32 digital outputs (FM 455 S) for actuators

Technical specifications

	6ES7 455-0VS00-0AE0	6ES7 455-1VS00-0AE0
Supply voltage		
Load voltage L+		
• Rated value (DC)	24 V	24 V
• permissible range, lower limit (DC)	20.4 V	20.4 V
• permissible range, upper limit (DC)	28.8 V	28.8 V
Input current		
from load voltage L+ (without load), max.	440 mA; typ. 370 mA	400 mA; typ. 330 mA
Power losses		
Power loss, typ.	12 W	10.7 W
Power loss, max.	17.3 W	16.2 W
Digital inputs		
Number/binary inputs	16	16
Input characteristic curve acc. to IEC 61131, Type 2	Yes	Yes
Input voltage		
• Rated value, DC	24 V	24 V
• for signal "0"	-3 to +5 V	-3 to +5 V
• for signal "1"	13 to 30 V	13 to 30 V
Input current		
• for signal "1", typ.	7 mA	7 mA
Cable length		
• Cable length, shielded, max.	1 000 m	1 000 m
• Cable length unshielded, max.	600 m	600 m

SIMATIC S7-400

Function modules

FM 455 controller module

Technical specifications (continued)

	6ES7 455-0VS00-0AE0	6ES7 455-1VS00-0AE0
Digital outputs		
Number/binary outputs		32
Functionality/short-circuit strength		Yes; Electronic
Limitation of inductive shutdown voltage to		L+ (-1.5 V)
Lamp load, max.		5 W
Controlling a digital input		Yes
Load resistance range		
• lower limit		240 Ω
• upper limit		4 kΩ
Output voltage		
• for signal "1", min.		L+ (-2.5 V)
Output current		
• for signal "1" rated value		0.1 A
• for signal "1" permissible range for 0 to 60 °C, min.		5 mA
• for signal "1" permissible range for 0 to 60 °C, max.		150 mA
• for signal "0" residual current, max.		0.5 mA
Parallel switching of 2 outputs		
• for logic links		Yes
Switching frequency		
• with resistive load, max.		100 Hz
• with inductive load, max.		0.5 Hz
• on lamp load, max.		100 Hz
Cable length		
• Cable length, shielded, max.		1 000 m
• Cable length unshielded, max.		600 m
Analog inputs		
Number of analog inputs	16; With thermocouples or 2-wire connection; 8 with Pt 100 or 4-wire connection	16; With thermocouples or 2-wire connection; 8 with Pt 100 or 4-wire connection
permissible input voltage for voltage input (destruction limit), max.	20 V	20 V
permissible input current for current input (destruction limit), max.	40 mA	40 mA
Input ranges (rated values), voltages		
• 0 to +10 V	Yes	Yes
• -1.75 to +11.75 V	Yes	Yes
• -80 mV to +80 mV	Yes	Yes
Input ranges (rated values), currents		
• 0 to 20 mA	Yes	Yes
• 0 to 23.5 mA	Yes	Yes
• -3.5 to +23.5 mA	Yes	Yes
• 4 to 20 mA	Yes	Yes
Input ranges (rated values), thermoelements		
• Type B	Yes	Yes
• Type J	Yes	Yes
• Type K	Yes	Yes
• Type R	Yes	Yes
• Type S	Yes	Yes

Technical specifications (continued)

	6ES7 455-0VS00-0AE0	6ES7 455-1VS00-0AE0
Input ranges (rated values), resistance thermometers • Pt 100	Yes	Yes
Thermocouple (TC) • for thermocouples • Temperature compensation - internal temperature compensation - external temperature compensation with Pt100	Type B, J, K, R, S Yes; Parameterizable Yes; Parameterizable	Type B, J, K, R, S Yes; Parameterizable Yes; Parameterizable
Resistance thermometer (RTD) • Characteristic linearization - for resistance thermometer	Pt100 (standard)	Pt100 (standard)
Characteristic linearization • Parameterizable	Yes	Yes
Cable length • Cable length, shielded, max.	200 m; 50 m at 80 mV and thermocouples	200 m; 50 m at 80 mV and thermocouples
Analog outputs		
Number of analog outputs	16	
Voltage output, short-circuit protection	Yes	
Voltage output, short-circuit current, max.	25 mA	
Current output, no-load voltage, max.	18 V	
Output ranges, voltage • 0 to 10 V • -10 to +10 V	Yes Yes	
Output ranges, current • 0 to 20 mA • -20 to +20 mA • 4 to 20 mA	Yes Yes Yes	
Connection of actuators • for voltage output 2-conductor connection • for current output 2-conductor connection	Yes Yes	
Load impedance (in rated range of output) • with voltage outputs, min. • with voltage outputs, capacitive load, max. • with current outputs, max. • with current outputs, inductive load, max.	1 k Ω 1 μ F 500 Ω 1 mH	
Cable length • Cable length, shielded, max.	200 m; 50 m at 80 mV and thermocouples	
Analog value creation		
Measurement principle	integrating	integrating
Integrations and conversion time/ resolution per channel • Resolution with overrange (bit including sign), max. • Conversion time (per channel)	14 bit; 12 or 14 bit, parameterizable 16.67 ms; for 12 bit: 16 2/3 ms for 60 Hz, 20 ms for 50 Hz; for 14 bit: 100 ms for 50 and 60 Hz	14 bit; 12 or 14 bit, parameterizable 16.67 ms; for 12 bit: 16 2/3 ms for 60 Hz, 20 ms for 50 Hz; for 14 bit: 100 ms for 50 and 60 Hz
Settling time • for resistive load • for capacitive load • for inductive load	0.2 ms 3.3 ms 0.5 ms	0.1 ms 3.3 ms 0.5 ms

SIMATIC S7-400

Function modules

FM 455 controller module

Technical specifications (continued)

	6ES7 455-0VS00-0AE0	6ES7 455-1VS00-0AE0
Encoder		
Connection of signal encoders		
• for voltage measurement	Yes	Yes
• for current measurement as 4-wire transducer	Yes	Yes
Connectable encoders		
• 2-wire sensor	Yes	Yes
- Permissible quiescent current (2-wire sensor), max.	1.5 mA	1.5 mA
Errors/accuracies		
Linearity error (relative to input area)	+/- 0,05 %	+/- 0,05 %
Temperature error (relative to input area)	+/- 0,005 %/K	+/- 0,005 %/K
Linearity error (relative to output area)	+/- 0,05 %	
Temperature error (relative to output area)	+/- 0,02 %/K	
Operational limit in overall temperature range		
• Voltage, relative to input area	+/-0.6 to +/-1%	+/-0.6 to +/-1%
• Current, relative to input area	+/-0.6 to +/-1%	+/-0.6 to +/-1%
• Resistance-type thermometer, relative to input area	+/-0.6 to +/-1%	+/-0.6 to +/-1%
• Voltage, relative to output area	+/- 0,5 %	
• Current, relative to output area	+/- 0,6 %	
Basic error limit (operational limit at 25 °C)		
• Voltage, relative to input area	+/-0.4 to +/-0.6 %	+/-0.4 to +/-0.6 %
• Current, relative to input area	+/-0.4 to +/-0.6 %	+/-0.4 to +/-0.6 %
• Resistance-type thermometer, relative to input area	+/-0.4 to +/-0.6 %	+/-0.4 to +/-0.6 %
• Voltage, relative to output area	+/- 0,4 %	
• Current, relative to output area	+/- 0,5 %	
Interference voltage suppression for $f = n \times (f_1 \pm 1\%)$, $f_1 =$ interference frequency		
• Series mode interference (peak value of interference < rated value of input range), min.	40 dB	40 dB
• common mode voltage (USS < 2.5 V), min.	70 dB	70 dB
Interrupts/diagnostics/status information		
Substitute values connectable	Yes; Parameterizable	Yes; Parameterizable
Control technology		
Number of closed-loop controllers	16; With thermocouples or 2-wire connection; 8 with Pt 100 or 4-wire connection	16; With thermocouples or 2-wire connection; 8 with Pt 100 or 4-wire connection
Galvanic isolation		
Galvanic isolation controller		
• between the channels	No	No
• between the channels and the backplane bus	Yes; Optocoupler	Yes; Optocoupler

Technical specifications (continued)

	6ES7 455-0VS00-0AE0	6ES7 455-1VS00-0AE0
Permissible potential difference		
between inputs and MANA (UCM)	2.5 V DC	2.5 V DC
between M internally and the inputs	75 VDC / 60 VAC	75 VDC / 60 VAC
Isolation		
Isolation checked with	500 V DC	500 V DC
Connection method		
required front connector	2x 48-pin	2x 48-pin
Dimensions		
Width	50 mm	50 mm
Height	290 mm	290 mm
Depth	210 mm	210 mm
Weight		
Weight, approx.	1 400 g	1 400 g

Ordering data

Ordering data	Order No.	Ordering data	Order No.
FM 455 C controller module	6ES7 455-0VS00-0AE0	Front connectors 48-pin • with screw contacts, 1 item • with screw contacts, 84 items • with spring-loaded terminals, 1 item • with crimp contacts, 1 item • with crimp contacts, 84 items	6ES7 492-1AL00-0AA0 6ES7 492-1AL00-1AB0 6ES7 492-1BL00-0AA0 6ES7 492-1CL00-0AA0 6ES7 492-1CL00-1AB0
with 16 analog outputs for 16 continuous controllers			
FM 455 S controller module	6ES7 455-1VS00-0AE0		
with 32 digital outputs for 16 step or pulse controllers			

SIMATIC S7-400

Function modules

FM 458-1 DP application module

Overview



SIMATIC FM 458-1 DP integrated in SIMATIC S7-400

- Designed for high-performance and user-configurable closed-loop control tasks in the SIMATIC S7-400.
- Can be adapted to individual requirements as required, such as:
Controlling, computing, closed-loop control as well as motion control. Can therefore be used flexibly for a wide variety of applications.
- Extensive library with approx. 300 function blocks:
E.g. simple functions such as AND, ADD and OR through to complex GMC (general motion control) blocks as virtual master or gear functions.
- User-friendly graphical configuration with the SIMATIC engineering tool CFC (Continuous Function Chart) and the D7-SYS add-on software package:
Optimum code generation by the compiler, therefore SCL is not required.
- PROFIBUS DP interface onboard.

SIMATIC FM 458-1 DP is based on more than 15 years experience with high-performance control systems and combines this know-how with the advantages of SIMATIC – the leading automation system for decades. In contrast to other function modules with static structures/functions, the FM 458-1 DP application module can be configured flexibly and adapted to individual requirements.

SIMATIC S7-400

Function modules

FM 458-1 DP application module
FM 458-1 DP basic module

Overview



- Basic module for handling arithmetic, closed-loop control and open-loop control tasks
- PROFIBUS DP interface for connection of distributed I/O and drives
- Modular design with expansion modules for I/O and communication

Technical specifications

6DD1 607-0AA2	
Supply voltage	
5 V DC	Yes
24 V DC	Yes
permissible range (ripple included), lower limit (DC)	4.8 V
permissible range (ripple included), upper limit (DC)	5.25 V
Input current	
Current consumption, typ.	1.5 A
Current consumption, max.	3 A
Encoder supply	
Backup battery	
• Battery operation	Yes
- Backup current, max.	15 μ A
Memory	
Backup	
• present	Yes; SRAM
Time of day	
Clock	
• Hardware clock (real-time clock)	Yes
• Resolution	500 ms
Digital inputs	
Number/binary inputs	8; Connector X2
Input voltage	
• Rated value, DC	24 V
• for signal "0"	-1 to +6 V
• for signal "1"	13.5 to 33 V
Input current	
• for signal "0", max. (permissible quiescent current)	0 mA
• for signal "1", typ.	3 mA; at 24 V
Input delay (for rated value of input voltage)	
• for standard inputs	
- at "0" to "1", max.	5 μ s
Interfaces	
PROFIBUS DP	
• equidistance	Yes; With connection to interrupt tasks
• Direct data exchange (slave-to-slave communication)	Yes
Interrupts/diagnostics/status information	
Alarms	
• Alarms	Yes
Galvanic isolation	
Galvanic isolation digital inputs	
• Galvanic isolation digital inputs	No; only via optional interface modules
Dimensions	
Required slots	1
Weight	
Weight, approx.	1 000 g

SIMATIC S7-400

Function modules

FM 458-1 DP application module
FM 458-1 DP basic module

Ordering data	Order No.	Order No.
FM 458-1 DP application module Basic module for computing, closed-loop control and open-loop control tasks; with PROFIBUS DP interface	6DD1 607-0AA2	
Micro Memory Card For FM 458-1 DP basic module		
2 MB	6ES7 953-8LL31-0AA0	
4 MB	6ES7 953-8LM20-0AA0	
8 MB	6ES7 953-8LP20-0AA0	
FM 458-1 DP Know-How-Protect For protection of technological application modules against unauthorized copying	6DD1 607-0GA0	
SC 64 interface cable To connect FM 458-1 to the serial port of a programming device/ PC	6DD1 684-0GE0	
SB10 interface module To connect 8 binary I/Os to FM 458-1 DP	6DD1 681-0AE2	
SB61 interface module To connect 8 binary I/Os to FM 458-1 DP, input voltage: 24/48 V DC	6DD1 681-0EB3	
SU12 interface module To connect 10 signals to FM 458-1 DP	6DD1 681-0AJ1	
RS 485 bus connector with 90° cable outlet Max. transfer rate 12 Mbit/s Without PG interface With PG interface	6ES7 972-0BA12-0XA0 6ES7 972-0BB12-0XA0	
RS 485 bus connector with angled cable outlet Max. transfer rate 12 Mbit/s Without PG interface With PG interface		6ES7 972-0BA42-0XA0 6ES7 972-0BB42-0XA0
RS 485 bus connector with 90° cable outlet for FastConnect connection system Max. transfer rate 12 Mbit/s Without PG interface		6ES7 972-0BA52-0XA0 6ES7 972-0BA52-0XB0
• 1 unit • 100 units With PG interface		6ES7 972-0BB52-0XA0 6ES7 972-0BB52-0XB0
PROFIBUS FastConnect bus cable Standard type with special design for quick mounting, 2-core, shielded, sold by the meter, max. delivery unit 1000 m, minimum ordering quantity 20 m Preferred lengths:		6XV1 830-0EH10
20 m		6XV1 830-0EN20
50 m		6XV1 830-0EN50
100 m		6XV1 830-0ET10

SIMATIC S7-400

Function modules

FM 458-1 DP application module
EXM 438-1 input/output expansion

Overview



- Optional plug-in expansion module for the FM 458-1 DP basic module
- For input and output of time-critical signals
- With digital and analog inputs/outputs
- Incremental and absolute value encoders can be connected
- 4 high-resolution analog outputs
- Fan-free operation up to 40°C

Technical specifications

6DD1 607-0CA1	
Supply voltage	
5 V DC	Yes
24 V DC	Yes; to be set up externally
Input current	
Current consumption, typ.	1.5 A
Encoder supply	
Output voltage	about 14 V (non-isolated)
Output current, rated value	100 mA
Output current	
• Short-circuit protection	Yes; Electronic
Digital inputs	
Number/binary inputs	16
Input voltage	
• Rated value, DC	24 V
• for signal "0"	-1 to +6 V or input open
• for signal "1"	+13 to +33 V
Input current	
• for signal "0", max. (permissible quiescent current)	0 mA
• for signal "1", typ.	3 mA
Input delay (for rated value of input voltage)	
• for standard inputs	
- at "0" to "1", max.	200 µs
Digital outputs	
Number/binary outputs	8
Functionality/short-circuit strength	Yes; electronic/thermal
• Response threshold, typ.	250 mA
Limitation of inductive shutdown voltage to	Supply voltage +1 V
Output voltage	
• for signal "0", max.	3 V
• for signal "1", max.	Supply voltage -2.5 V
Output current	
• for signal "1" rated value	50 mA
• for signal "1" permissible range for 0 to 40 °C, min.	100 mA
• for signal "0" residual current, max.	20 µA
• Total switching current	80% at 50 °C all outputs 50 mA
Output delay with resistive load	
• "0" to "1", max.	15 µs

6DD1 607-0CA1	
Analog inputs	
Number of analog inputs	5; Differential inputs
Input ranges (rated values), voltages	
• -10 V to +10 V	Yes; -10 V: +/-4 LSB; to +10 V: +/-4 LSB (1 LSB = 4.88 mV)
• Input resistance (-10 V to +10 V)	470 kΩ
Analog outputs	
Number of analog outputs	8; 4 outputs 16 bit; 4 outputs 12 bit
Voltage output, short-circuit protection	Yes; relative to frame
Voltage output, short-circuit current, max.	16 bits: 27 mA; 12 bits: 100 mA
Output ranges, voltage	
• -10 to +10 V	Yes
Analog value creation	
Integrations and conversion time/ resolution per channel	
• Resolution with overrange (bit including sign), max.	4 AO: 16 bits, 4 AO: 12 bits, 5 AI: 12 bits
• Conversion time (per channel)	4 AO (16 bits): 2 µs; 4 AO (12 bits): 4 µs; 5 AI: 45 µs
Encoder	
Number of connectable encoders, max.	12; 8 incremental encoders (syn- chronizable), 4 absolute encoders
Connectable encoders	
• Incremental encoder (symmetrical)	Yes
• Incremental encoder (asymmetrical)	Yes
• Absolute encoder (SSI)	Yes; Single or multturn encoder with SSI (synchronous serial) or EnDat interface
Encoder signals, incremental encoder (symmetrical)	
• Trace mark signals	1) for tracks A and B (90° out of phase), poss. with zero pulse N; 2) for separate forward and backward track
• Input signal	With 0 signal: -5 to 0 V; with 1 signal: +3 to +5 V; permissible input voltage range: differential voltage -5 to +5 V; max. input current: 15 mA (import- tant: not limited on module side!)

SIMATIC S7-400

Function modules

FM 458-1 DP application module
EXM 438-1 input/output expansion

Technical specifications (continued)

6DD1 607-0CA1	
Encoder signals, incremental encoder (asymmetrical)	
<ul style="list-style-type: none"> Trace mark signals 	Track A and B (phase-shifted by 90 degrees), possibly with zero pulse N
<ul style="list-style-type: none"> Input voltage 	with 0 signal: -30 to +4 V (at 15 mA load); with 1 signal: +8 to 30 V (at 15 mA load); permissible input voltage range: differential voltage -30 to +30 V
Encoder signals, absolute encoder (SSI)	
<ul style="list-style-type: none"> Input signal Data signal Clock frequency, max. 	5 V acc. to RS 422 Dual-, Gray-, Gray-Excess-Code 2 MHz; 100 kHz to 2 MHz (depending on cable length)
Errors/accuracies	
Linearity error (relative to output area)	(+/- 1 LSB)
Galvanic isolation	
Galvanic isolation digital inputs	
<ul style="list-style-type: none"> Galvanic isolation digital inputs 	No
Galvanic isolation digital outputs	
<ul style="list-style-type: none"> Galvanic isolation digital outputs 	No
Galvanic isolation analog inputs	
<ul style="list-style-type: none"> Galvanic isolation analog inputs 	No
Galvanic isolation analog outputs	
<ul style="list-style-type: none"> Galvanic isolation analog outputs 	No
Dimensions	
Required slots	1
Weight	
Weight, approx.	1 kg

Ordering data

Order No.

EXM 438-1 input/output expansion	6DD1 607-0CA1
For direct exchange of digital and analog signals between FM 458-1 DP and the plant	
SB10 interface module	6DD1 681-0AE2
To connect 8 binary inputs or outputs to FM 458-1 DP	
SB61 interface module	6DD1 681-0EB3
To connect 8 binary inputs to FM 458-1 DP, input voltage: 24/48 V DC	
SB71 interface module	6DD1 681-0DH1
To connect 8 binary outputs to FM 458-1 DP, output voltage: 24/48 V DC	
SU12 interface module	6DD1 681-0AJ1
To connect 10 signals to FM 458-1 DP	
SU13 interface module	6DD1 681-0GK0
To connect 50 signals to FM 458-1 DP	
SC 62 interface cable	6DD1 684-0GC0
To connect EXM 438-1 with up to 5 SBxx or SU12	
SC 63 interface cable	6DD1 684-0GD0
To connect EXM 438-1 with an SU13	

SIMATIC S7-400

Function modules

FM 458-1 DP application module – EXM 448 universal communications expansion module

Overview



- Optional expansion module for the FM 458-1 DP basic module
- For fast communication over PROFIBUS DP or SIMOLINK
- EXM 448: With vacant slot for a MASTERDRIVES option module

Technical specifications

6DD1 607-0EA0	
Supply voltage 5 V DC	Yes
Input current Current consumption, typ.	0.8 A
Dimensions Required slots	1
Weight Weight, approx.	0.8 kg

Ordering data

EXM 448 universal communications expansion module
For fast communication, for example, with drives; with free slot for MASTERDRIVES option module

Order No.

6DD1 607-0EA0

SIMATIC S7-400

Function modules

FM 458-1 DP application module – EXM 448-2 universal communications expansion module

Overview



- Optional plug-in expansion module for the FM 458-1 DP basic module
- For high-speed communication over up to 2 SIMOLINK interfaces
- For coupling several FM 458-1 DP application modules in synchronism with the sampling time

Technical specifications

	6DD1 607-0EA2
Supply voltage 5 V DC	Yes
Input current Current consumption, typ.	0.6 A
Dimensions Required slots	1
Weight Weight, approx.	0.9 kg

Ordering data

EXM 448-2 universal communications expansion
For high-speed communication with drives; for establishing two SIMOLINK fiber optic connections

Order No.

6DD1 607-0EA2

SIMATIC S7-400

Function modules

FM 458-1 DP application module
D7-SYS

Overview

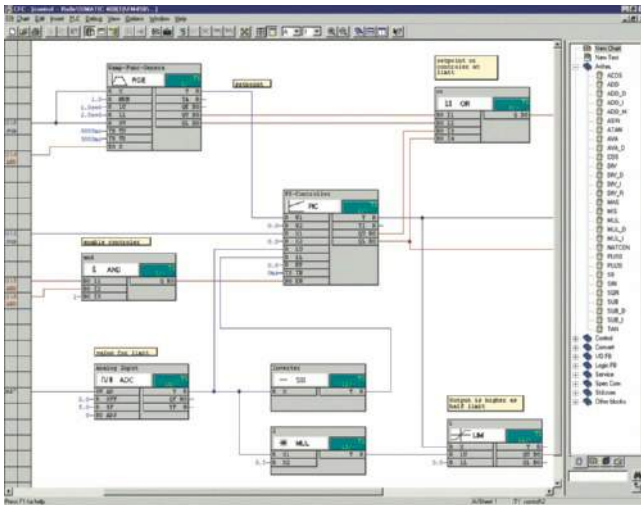

- Add-on for STEP 7/CFC/SFC for configuration of control and automation tasks with T400, FM 458, SIMADYN D or SIMATIC TDC
- Contains function blocks for every application
- Scope of delivery: Software packages D7-SYS, CFC, SFC, TH-PO
- Optional:
D7-FB-Gen, function block generator for the creation of customized function blocks

Ordering data

Order No.

SIMATIC D7-SYS V8.0

Task:
Function block library for configuring closed-loop control and automation tasks

Target system:

SIMATIC S7-400/FM 458/
SIMATIC TDC/T400/SIMADYN

Requirement:

Windows XP, Windows 7 32/64-bit,
Windows Server 2003/2008

Type of delivery:

on CD, German, English,
with electronic documentation

Floating license

6ES7 852-0CC03-0YA5

Upgrade License V7.x and higher

6ES7 852-0CC03-0YE5

Software Update Service¹⁾

6ES7 852-0CC01-0YL5

SIMATIC D7 FB Gen V2.1

6DD1 805-5DA0

Function block generator

SIMATIC Manual Collection

6ES7 998-8XC01-8YE0

Electronic manuals on DVD,
multilingual: LOGO!, SIMADYN,
SIMATIC bus components,
SIMATIC C7, SIMATIC distributed I/O,
SIMATIC HMI, SIMATIC Sensors,
SIMATIC NET, SIMATIC PC Based
Automation, SIMATIC PCS 7,
SIMATIC PG/PC, SIMATIC S7,
SIMATIC Software, SIMATIC TDC

SIMATIC Manual Collection update service for 1 year

6ES7 998-8XC01-8YE2

Current "Manual Collection" DVD
and the three subsequent updates

¹⁾ For more information on the software update service, see Section 11,
page 11/3.

SIMATIC S7-400

Function modules

FM 458-1 DP application module Accessories

Overview SC64 interface cable



(Similar to figure)

Interface cable for FM 458-1 DP basic module and SB10, SB60, SB61 and SU12 interface modules.

Overview SC63 interface cable



This cable is used to connect the SIMATIC TDC SM500 peripheral (I/O) module or the SIMATIC S7-400 EXM 438-1 expansion module to a SU13 interface module.

Overview SC62 interface cable



This cable is used to connect the SIMATIC TDC SM500 peripheral module (I/O) or the SIMATIC S7-400 EXM 438-1 expansion module to up to 5 interface modules SB10, SB60, SB70, SB61 SB71 and/or SU12.

Overview SB10 interface module



Similar to figure.

The interface module is used to connect 8 digital inputs or outputs.

Overview SB61 interface module



It is used to connect 8 digital inputs with conversion from 24/48 V DC to 24 V DC.

Overview SU12 interface module



The interface module is used to connect 10 signals; there is no electronic conversion.

Overview SB71 interface module



The interface module is used to connect 8 digital outputs with conversion of the 24 V DC voltage on the module side to a max. of 24/48 V DC/AC on the plant side using transistors.

Overview SU13 interface module



This interface module can be used to connect 50 signals; there is no electronic conversion.

SIMATIC S7-400

Function modules

FM 458-1 DP application module Accessories

Technical specifications

Technical specifications SB10 interface module

Number of digital inputs or outputs	8
Electrical isolation	No
Max. cable cross-section	1.5 mm ²
Dimensions (W x H x D) in mm	45 x 130 x 156
Weight	0.3 kg

Technical specifications SB61 interface module

Number of digital inputs for	8
• Input voltage	24/48 V DC
Electrical isolation	Yes, via optocoupler
Max. cable cross-section	1.5 mm ²
Dimensions (W x H x D) in mm	45 x 130 x 156
Weight	0.32 kg

Technical specifications SB71 interface module

Number of digital outputs	8
• Output voltage, max	24/48 V DC
Output current, max.	40 mA, short-circuit proof
Electrical isolation	Yes, via optocoupler
Max. cable cross-section	1.5 mm ²
Dimensions (W x H x D) in mm	45 x 130 x 156

Technical specifications SU12 interface module

Number of signal cables which can be connected	10
Signal amplitude per signal, max.	60 V, 0.5 A
Electrical isolation	No
Max. cable cross-section	1.5 mm ²
Dimensions (W x H x D) in mm	45 x 130 x 156
Weight	0.28 kg

Technical specifications SU13 interface module

Number of signal cables which can be connected	50
Signal amplitude per signal, max.	60 V, 0.5 A
Electrical isolation	No
Max. cable cross-section	1.5 mm ²
Dimensions (W x H x D) in mm	45 x 130 x 156
Weight	0.3 kg

Ordering data

Order No.

SC64 interface cable between FM 458-1 DP (X2) module with SBxx or SU12 interface module, 2 m long	6DD1 684-0GE0
SC62 interface cable between SM500 or EXM 438-1 module and max. 5 SB10, SB60, SB70, SB61 SB71 interface modules and/or SU12, 2 m long	6DD1 684-0GC0
SC63 interface cable between SM500 or EXM 438-1 module and SU13 interface module, 2 m long	6DD1 684-0GD0
SB10 interface module 8 digital inputs/outputs 24 V DC	6DD1 681-0AE2
SB61 interface module 8 digital inputs 24/48 V DC	6DD1 681-0EB3
SB71 interface module 8 digital outputs with transistors, 24/48 V DC	6DD1 681-0DH1
SU12 interface module with plug-in connector, 10-pole	6DD1 681-0AJ1
SU13 interface module with screw-type plug-in connector	6DD1 681-0GK0

SIMATIC S7-400

SIPLUS function modules

SIPLUS FM 450-1 counter modules

Overview



- Two-channel, intelligent counter module for simple counting tasks
- For direct connection of incremental encoders
- Comparison functions with two definable comparison values
- Integrated digital outputs for the output of the reaction on reaching the comparison values

Note:

SIPLUS extreme products are based on Siemens Industry standard products. The contents listed here were taken from the respective standard products. SIPLUS extreme specific information was added.

SIPLUS FM 450-1 counter module

Order No.	6AG1 450-1AP00-4AE0
Order No. based on	6ES7 450-1AP00-0AE0
Ambient temperature range	0 ... +60 °C
Conformal coating	Coating of the printed circuit boards and the electronic components
Technical data	The technical data of the standard product applies except for the ambient conditions.
Ambient conditions	
Relative humidity	100%, condensation/frost permissible. No commissioning if condensation present.
Biologically active substances, compliance with EN 60721-3-3	Class 3B2 mold and fungal spores (excluding fauna). The supplied plug covers must remain in place over the unused interfaces during operation!
Chemically active substances, compliance with EN 60721-3-3	Class 3C4 incl. salt spray in accordance with EN60068-2-52 (degree of severity 3). The supplied plug covers must remain in place over the unused interfaces during operation!
Mechanically active substances, compliance with EN 60721-3-3	Class 3S4 incl. sand, dust. The supplied plug covers must remain in place over the unused interfaces during operation!
Air pressure (depending on the highest positive temperature range specified)	1 080 ... 795 hPa (-1 000 ... +2 000 m) see ambient temperature range 795 ... 658 hPa (+2 000 ... +3 500 m) derating 10 K 658 ... 540 hPa (+3 500 ... +5 000 m) derating 20 K

Note:

We offer incremental sensors and preassembled connecting cables for counting and positioning functions under SIMODRIVE Sensor or Motion Connect 500.

For technical documentation on SIPLUS, see:
www.siemens.com/siplus-extreme

Ordering data	Order No.
SIPLUS FM 450-1 counter module (medial exposure) with 2 channels, max. 500 kHz; for incremental encoder	6AG1 450-1AP00-4AE0
Accessories	See SIMATIC FM 450-1, page 6/78

SIMATIC S7-400

SIPLUS function modules

SIPLUS DCF 77 radio clock module

Overview



This module can be used to synchronize the real-time clock of the SIMATIC S7-200, S7-300 and S7-400 automation systems with the official time of the DCF 77 time signal transmitter of the Physikalisch-Technische Bundesanstalt Braunschweig.

The time is received by means of a DCF receiver (antenna with electronics) which is connected via two digital inputs on the SIMATIC and SIPLUS together with a software driver included in the scope of delivery (function block FB). The function blocks are available on the Internet for downloading.

www.siemens.com/siplus - Support - Tools and Downloads!

Technical specifications

SIPLUS DCF 77 radio clock module	
Radio frequency	77.5 Hz
Power supply	24 V DC (20.4 to 28.8 DC)
Power consumption, typ.	50 mA
Dimensions (W x H x D)	75 mm x 125 mm ¹⁾ x 75 mm

¹⁾ Additionally 25 mm (0.98 in) for heavy duty threaded joint and bending radius for cables

Ordering data

Order No.

SIPLUS DCF 77 radio clock module

6AG1 057-1AA03-0AA0

For synchronizing SIMATIC S7-200, S7-300 and S7-400 with the official time of the DCF 77 time signal transmitter of the Physikalisch-Technische Bundesanstalt Braunschweig

Overview



- For high-performance transmission of messages via point-to-point connections (high message rate)
- Physical interface: RS 422/RS 485 (X.27)
- Up to 32 nodes
- Protocol implemented: ASCII, 3964 (R)
- Simple parameterization via a parameterization tool integrated into STEP 7

Technical specifications

6ES7 440-1CS00-0YE0	
Supply voltage	
5 V DC	Yes
24 V DC	Yes
Input current	
from backplane bus 5 V DC, max.	360 mA
Power losses	
Power loss, typ.	1.7 W
Memory	
Memory requirements per interface in memory card of S7-CPU	1 to 5 Kbytes for parameters
Interfaces	
Number of interfaces	1
Interface physics, RS 422/RS 485 (X.27)	Yes
RS 422/485, cable length, shielded, max.	1 200 m
Point-to-point	
• Integrated protocol driver	
- 3964 (R)	Yes
- ASCII	Yes
• Transmission speed, RS 422/485	
- with 3964 (R) protocol, max.	115.2 kbit/s
- with ASCII protocol, max.	115.2 kbit/s
Dimensions	
Width	25 mm
Height	290 mm
Depth	210 mm
Weight	
Weight, approx.	600 g

Ordering data

Ordering data	Order No.
CP 440 communications module	6ES7 440-1CS00-0YE0
with one RS 422/485 (X.27) interface	
RS 422/485 connecting cable	
for linking to SIMATIC S7	
5 m	6ES7 902-3AB00-0AA0
10 m	6ES7 902-3AC00-0AA0
50 m	6ES7 902-3AG00-0AA0

SIMATIC S7-400

Communication

CP 441-1, CP 441-2

Overview



- For fast, high-performance serial data exchange via point-to-point connection
- 2 versions:
 - CP 441-1 with 1 variable interface for easy point-to-point coupling.
 - CP 441-2 with 2 variable interfaces for high-performance point-to-point connection.
- Plug-in interface modules for different physical transmission properties: RS 232C (V.24), 20 mA (TTY) or RS 422/RS 485 (X.27)
- Implemented protocols: ASCII, 3964 (R), printer driver; for CP 441-2 additional RK 512 and Modbus RTU (reloadable)
- Simple parameter assignment using tool integrated in STEP 7

Technical specifications

	6ES7 441-1AA05-0AE0 CP 441-1	6ES7 441-2AA05-0AE0 CP 441-2
Supply voltage		
5 V DC	Yes	Yes
24 V DC	Yes	Yes
Input current		
from backplane bus 5 V DC, max.	300 mA	300 mA
Power losses		
Power loss, typ.	2.1 W; incl. 1x20 mA TTY module	2.7 W; incl. 2x20mA TTY module
Memory		
Memory requirements per interface in memory card of S7-CPU	1 to 5 KB for parameters; 0 to 55 KB for message texts	1 to 5 KB for parameters; 0 to 55 KB for message texts; 0 to 64 KB for loadable drivers
Interfaces		
Number of interfaces	1; variable	2; variable
Interface physics, 20 mA (TTY)	Yes	Yes
Interface physics, RS 232C (V.24)	Yes	Yes
Interface physics, RS 422/RS 485 (X.27)	Yes	Yes
20mA (TTY), cable length, shielded, max.	1 000 m; At 9600 bps	1 000 m; At 9600 bps
RS 232, cable length, shielded, max.	15 m; At 115200 bps	15 m; At 115200 bps
RS 422/485, cable length, shielded, max.	1 200 m; At 19200 bps	1 200 m; At 19200 bps
Point-to-point		
• Transmission rate, max.	115.2 kbit/s; Min. 300 bps	115.2 kbit/s; Min. 300 bps
• supported printers	HP-Deskjet, HP-Laserjet, IBM-Proprinter, user-defined	HP-Deskjet, HP-Laserjet, IBM-Proprinter, user-defined
• Integrated protocol driver		
- 3964 (R)	Yes	Yes
- ASCII	Yes	Yes
- RK512	No	Yes
- Printer	Yes	Yes
- customer-specific drivers reloadable	No	No
• Transmission speed, 20 mA (TTY)		
- with 3964 (R) protocol, max.	19.2 kbit/s	19.2 kbit/s
- with ASCII protocol, max.	19.2 kbit/s	19.2 kbit/s
- with printer driver, max.,	19.2 kbit/s	19.2 kbit/s
- with RK 512 protocol, max.		19.2 kbit/s

Technical specifications (continued)

	6ES7 441-1AA05-0AE0 CP 441-1	6ES7 441-2AA05-0AE0 CP 441-2
<ul style="list-style-type: none"> • Transmission speed, RS 422/485 <ul style="list-style-type: none"> - with 3964 (R) protocol, max. 115.2 kbit/s - with ASCII protocol, max. 115.2 kbit/s - with printer driver, max., 115.2 kbit/s - with RK 512 protocol, max. 115.2 kbit/s • Transmission speed, RS232 <ul style="list-style-type: none"> - with 3964 (R) protocol, max. 115.2 kbit/s - with ASCII protocol, max. 115.2 kbit/s - with printer driver, max., 115.2 kbit/s - with RK 512 protocol, max. 115.2 kbit/s 		
Ambient conditions		
Operating temperature		
• Min.	0 °C	0 °C
• max.	60 °C	60 °C
Relative humidity		
• Operation, max.	95 %	95 %
Dimensions		
Width	25 mm	25 mm
Height	290 mm	290 mm
Depth	210 mm	210 mm
Weight		
Weight, approx.	580 g; Interface modules: 80 g	580 g; Interface modules: 80 g

Ordering data

	Order No.		Order No.
CP 441-1 communications module	6ES7 441-1AA05-0AE0	TTY connecting cable	
With 1 variable interface for interface submodules; including configuration package on CD		5 m	6ES7 902-2AB00-0AA0
		10 m	6ES7 902-2AC00-0AA0
		50 m	6ES7 902-2AG00-0AA0
CP 441-2 communications module	6ES7 441-2AA05-0AE0	RS 422/485 connecting cable	
With 2 variable interfaces for interface submodules; including configuration package on CD		5 m	6ES7 902-3AB00-0AA0
		10 m	6ES7 902-3AC00-0AA0
		50 m	6ES7 902-3AG00-0AA0
Interface submodules		Loadable drivers for CP 441-2	
RS 232C (V.24)	6ES7 963-1AA10-0AA0	Modbus master (RTU format)	
20 mA (TTY)	6ES7 963-2AA10-0AA0	• Single license	6ES7 870-1AA01-0YA0
RS 422/485 (X.27)	6ES7 963-3AA10-0AA0	• Single license, without software or documentation	6ES7 870-1AA01-0YA1
RS 232 connecting cable		Modbus slave (RTU format)	
5 m	6ES7 902-1AB00-0AA0	• Single license	6ES7 870-1AB01-0YA0
10 m	6ES7 902-1AC00-0AA0	• Single license, without software or documentation	6ES7 870-1AB01-0YA1
15 m	6ES7 902-1AD00-0AA0		

SIMATIC S7-400

Communication

Loadable drivers for CP 441-2 and CP 341

Overview

- Drivers for Modbus protocol with RTU message format; communication as master or slave
- Downloadable onto CP 341 and CP 441-2 (6ES7 441-2AA04-0AE0)

Technical specifications

Parameterization software	Loadable drivers for CP 441-2 and CP 341		Modbus slave
Type of license	Simple license, copy license		<ul style="list-style-type: none"> • Modbus protocol with RTU format
Target system	SIMATIC CP 341, SIMATIC CP 441-2		<ul style="list-style-type: none"> • Master/slave coupling: SIMATIC S7 is slave
Technical specifications	Modbus Master		
	<ul style="list-style-type: none"> • Modbus protocol with RTU format • Master/slave coupling: SIMATIC S7 is master • Function codes implemented: 01, 02, 03, 04, 05, 06, 07, 08, 11, 12, 15, 16 • No V.24 control and signal lines • CRC polynomial: $x^{16} + x^{15} + x^2 + 1$ • Interfaces: TTY (20 mA); V.24 (RS 232 C); X.27 (RS 422/485) 2-wire or 4-wire • Receive mailbox specified on BRCV • Character delay time 3.5 characters or multiple thereof • Broadcast message possible • Transmission rate 300 bit/s up to 76800 bit/s (TTY up to 19200 bit/s) • Character frame • With/without RS 485 operation for 2-wire connections • With/without modem operation (ignore smudge characters) • Response monitoring time 100 ms to 25.5 s in steps of 100 ms • Factor for the character delay time 1-10 • Default setting of receive line when using the X.27 interface module 	Adjustable parameters	<ul style="list-style-type: none"> • Function codes implemented: 01, 02, 03, 04, 05, 06, 08, 15, 16 • No V.24 control and signal line • CRC polynomial: $x^{16} + x^{15} + x^2 + 1$ • Interfaces: TTY (20 mA), V.24 (RS 232C), X.27 (RS 422/485) 2-wire or 4-wire • Communications FB 180, instance DB 180 (use of a multi-instance) • Conversion of the Modbus data address to S7 data areas. Data areas which can be processed: DB, bit memories, outputs, inputs, timers, counters • Character delay time 3.5 characters or multiple thereof • Transmission rate 300 bit/s up to 76800 bit/s (TTY up to 19200 bit/s) • Character frame • Slave address of CP (1 to 255) • With/without RS 485 operation for 2-wire connection • With/without modem operation (ignore smudge characters) • Factor for the character delay time 1-10 • Number of work DB (for FB processing) • Enabling of memory areas for writing by the master • Default setting of receive line when using the X.27 interface module • Conversion of Modbus addresses to S7 data areas
Adjustable parameters			

Ordering data	Order No.		Order No.
<p>Modbus Master V3.1</p> <p>Task: Communication via Modbus protocol with RTU format, SIMATIC S7 as master</p> <p>Requirement: CP 341 or CP 441-2; STEP 7 V4.02 and higher</p> <p>Delivery package: Driver program/documentation, English, German, French</p> <p>Single license</p> <p>Single license, without software and documentation</p>	<p>6ES7 870-1AA01-0YA0</p> <p>6ES7 870-1AA01-0YA1</p>	<p>SIMATIC Manual Collection</p> <p>Electronic manuals on DVD, multilingual: LOGO!, SIMADYN, SIMATIC bus components, SIMATIC C7, SIMATIC distributed I/O, SIMATIC HMI, SIMATIC Sensors, SIMATIC NET, SIMATIC PC Based Automation, SIMATIC PCS 7, SIMATIC PG/PC, SIMATIC S7, SIMATIC Software, SIMATIC TDC</p>	<p>6ES7 998-8XC01-8YE0</p>
<p>Modbus Slave V3.1</p> <p>Task: Communication via Modbus protocol with RTU format, SIMATIC S7 as slave</p> <p>Requirement: CP 341 or CP 441-2; STEP 7 V4.02 and higher</p> <p>Delivery package: Driver program/documentation, English, German, French</p> <p>Single license</p> <p>Single license, without software and documentation</p>	<p>6ES7 870-1AB01-0YA0</p> <p>6ES7 870-1AB01-0YA1</p>	<p>SIMATIC Manual Collection update service for 1 year</p> <p>Current "Manual Collection" DVD and the three subsequent updates</p>	<p>6ES7 998-8XC01-8YE2</p>

SIMATIC S7-400

Communication

CP 443-5 Basic

Overview



DP-M	DP-S	FMS	PG/OP	S7/S5	
		●	●	●	

- Connection of the S7-400 to PROFIBUS
- Communication services:
 - PG/OP communication
 - S7 communication
 - Open communication (SEND/RECEIVE)
 - PROFIBUS FMS
- Time synchronization
- Easy programming and configuration over PROFIBUS
- Cross-network programming device communication through S7 routing
- Can be easily integrated into the SIMATIC S7-400 system
- Modules can be replaced without the need for a PG
- SIMATIC H system operation for redundant S7 communication

Technical specifications

Order No.	6GK7 443-5FX02-0XE0
Product-type designation	CP 443-5 Basic
Transmission rate	
Transmission rate at interface 1 in accordance with PROFIBUS	9.6 kbit/s ... 12 Mbit/s
Interfaces	
Number of electrical connections at interface 1 in accordance with PROFIBUS	1
Design of electrical connection at interface 1 in accordance with PROFIBUS	9-pin Sub-D socket (RS485)
Supply voltage, current consumption, power loss	
Type of voltage of supply voltage	DC
Supply voltage 1 from backplane bus	5 V
Relative symmetrical tolerance at 5 V with DC	5 %
Consumed current from backplane bus at 5 V for DC Typical	1 A
Resistive loss	5.5 W
Permitted ambient conditions	
Ambient temperature	
• during operating	0 ... 60 °C
• during storage	-40 ... +70 °C
• during transport	-40 ... +70 °C
• Comment	-
Relative humidity at 25 °C without condensation during operating maximum	95 %
Protection class IP	IP20
Design, dimensions and weight	
Module format	
Width	25 mm
Height	290 mm
Depth	210 mm
Net weight	0.65 kg
Product properties, functions, components general	
Number of modules	
• per CPU maximum	14
• note	-

Technical specifications (continued)

Order No.	6GK7 443-5FX02-0XE0
Product-type designation	CP 443-5 Basic
Performance data	
<u>Performance data open communication</u>	
Number of possible connections for open communication by means of SEND/RECEIVE blocks maximum	32
Data volume as user data per connection for open communication by means of SEND/RECEIVE blocks maximum	240 byte
<u>Performance data FMS functions</u>	
Number of possible connections for FMS connection maximum	48
Amount of data of the variables	
• for READ job maximum	237 byte
• for WRITE job maximum	233 byte
Number of variables	
• Configurable from server to FMS partner	512
• Loadable from server to FMS partner	2 640
<u>Performance data S7 communication</u>	
Number of possible connections for S7 communication	
• maximum	48
• with PG connections maximum	-
• with PG/OP connections maximum	-
• note	-
<u>Performance data multi-protocol mode</u>	
Number of possible connections of which 2 reserved for PG/OP communication for multi-protocol operation maximum	59
Product functions management, configuration	
Configuration software required	

Ordering data

Order No.

CP 443-5 Basic communications processor	6GK7 443-5FX02-0XE0
Communications processor for connection of S7-400 to PROFIBUS, FMS, open communication, PG/OP and S7 communication; with electronic manual on CD-ROM	
PROFIBUS FastConnect bus connector RS485	
With 90° cable outlet; insulation displacement technology, max. transmission rate 12 Mbit/s (1 unit)	
• Without PG interface	6ES7 972-0BA52-0XA0
• With PG interface	6ES7 972-0BB52-0XA0
PROFIBUS bus connector IP20	
With connection to PPI, MPI, PROFIBUS	
• Without PG interface	6ES7 972-0BA12-0XA0
• With PG interface	6ES7 972-0BB12-0XA0
PROFIBUS bus terminal 12M	6GK1 500-0AA10
Bus terminal for connection of PROFIBUS nodes at up to 12 Mbit/s with connecting cable	

SIMATIC S7-400

Communication

CP 443-5 Extended

Overview



DP-M	DP-S	FMS	PG/OP	S7/S5	
●			●	●	

- PROFIBUS DP master with electrical interface for connecting the SIMATIC S7-400 to PROFIBUS at up to 12 Mbit/s (including 45.45 Kbit/s)
- For setting up additional PROFIBUS DP lines
- Communication services:
 - PROFIBUS DP
 - PG/OP communication
 - S7 communication
 - Open communication (SEND/RECEIVE)
- Time synchronization
- Easy programming and configuration over PROFIBUS
- Cross-network programming device communication through S7 routing
- Can be easily integrated into the SIMATIC S7-400 system
- Module replacement without PG
- SIMATIC H system operation for redundant S7 communication or DP master communication
- Data record routing (PROFIBUS DP)
- Adding or modifying distributed I/O during operation

Technical specifications

Order No.	6GK7 443-5DX05-0XE0
Product-type designation	CP 443-5 Extended
Transmission rate	
Transmission rate at interface 1 in accordance with PROFIBUS	9.6 kbit/s ... 12 Mbit/s
Interfaces	
Number of electrical connections at interface 1 in accordance with PROFIBUS	1
Design of electrical connection at interface 1 in accordance with PROFIBUS	9-pin Sub-D socket (RS485)
Supply voltage, current consumption, power loss	
Type of voltage of supply voltage	DC
Supply voltage 1 from backplane bus	5 V
Relative symmetrical tolerance at 5 V with DC	5 %
Consumed current from backplane bus at 5 V for DC Typical	0.6 A
Resistive loss	5.5 W
Permitted ambient conditions	
Ambient temperature	0 ... 60 °C
• during operating	-40 ... +70 °C
• during storage	-40 ... +70 °C
• during transport	-
• Comment	-
Relative humidity at 25 °C without condensation during operating maximum	95 %
Protection class IP	IP20
Design, dimensions and weight	
Module format	
Width	25 mm
Height	290 mm
Depth	210 mm
Net weight	0.65 kg

Order No.	6GK7 443-5DX05-0XE0
Product-type designation	CP 443-5 Extended
Product properties, functions, components general	
Number of modules	14
• per CPU maximum	The number of CPs that can be operated as DP masters depends on the number of CP 443-1 Advanced processors operating in the S7-400 station as PROFINET IO controllers. Up to 10 CPs can be operated in total: up to 4 as PROFINET IO controllers (CP 443-1 Advanced); up to 10 as DP masters (CP 443-5 Extended)
• note	
Performance data	
<u>Performance data open communication</u>	
Number of possible connections for open communication by means of SEND/RECEIVE blocks maximum	32
Data volume as user data per connection for open communication by means of SEND/RECEIVE blocks maximum	240 byte
<u>Performance data PROFIBUS DP</u>	
Service as DP master DPV1	Yes
Number of DP slaves on DP master usable	125
Amount of data	
• of the address area of the inputs as DP master overall	4 096 byte
• of the address area of the outputs as DP master overall	4 096 byte
• of the address area of the inputs per DP slave	244 byte
• of the address area of the outputs per DP slave	244 byte

Technical specifications (continued)

Order No.	6GK7 443-5DX05-0XE0
Product-type designation	CP 443-5 Extended
<u>Performance data S7 communication</u>	
Number of possible connections for S7 communication	
• maximum	48
• with PG connections maximum	-
• with PG/OP connections maximum	-
• note	-
<u>Performance data multi-protocol mode</u>	
Number of active connections with multi-protocol mode	
• without DP maximum	59
• with DP maximum	54

Order No.	6GK7 443-5DX05-0XE0
Product-type designation	CP 443-5 Extended
Product functions management, configuration	
Configuration software required	STEP 7 V5.4 SP4 or higher, or STEP 7 V11.0 or higher

Ordering data

Ordering data	Order No.
CP 443-5 Extended communications processor for connection of the SIMATIC S7-400 to PROFIBUS Extended version for PROFIBUS DP; with electronic manual on CD-ROM	6GK7 443-5DX05-0XE0
PROFIBUS FastConnect bus connector RS485 With 90° cable outlet; insulation displacement technology, max. transmission rate 12 Mbit/s (1 unit) <ul style="list-style-type: none"> • Without PG interface • With PG interface 	6ES7 972-0BA52-0XA0 6ES7 972-0BB52-0XA0

Ordering data	Order No.
PROFIBUS bus connector IP20 With connection to PPI, MPI, PROFIBUS <ul style="list-style-type: none"> • Without PG interface • With PG interface 	6ES7 972-0BA12-0XA0 6ES7 972-0BB12-0XA0
PROFIBUS bus terminal 12M Bus terminal for connection of PROFIBUS nodes at up to 12 Mbit/s with connecting cable	6GK1 500-0AA10

SIMATIC S7-400

Communication

CP 443-1

Overview



Communications processor for connecting a SIMATIC S7-400 to Industrial Ethernet networks, also as PROFINET IO controller or in SIMATIC H systems.

The CP supports:

- PG/OP communication
- S7 communication
- Open communication (SEND/RECEIVE)
- PROFINET communication
- IT communication

The communications processor can also be used for redundant S7 communication in SIMATIC H systems and for fail-safe applications (PROFIsafe) in connection with an S7-400 F-CPU.

ISO	TCP/UDP	PN	MRP	IT	IP-R	PG/OP	S7/S5
●	●	●	●	●		●	●

6

Technical specifications

Order No.	6GK7 443-1EX30-0XE0
Product-type designation	CP 443-1
Transmission rate	
Transfer rate at the interface 1	10 ... 100 Mbit/s
Interfaces	
Number of electrical connections at interface 1 in accordance with Industrial Ethernet	2
Design of electrical connection at interface 1 in accordance with Industrial Ethernet	RJ45 port
Supply voltage, current consumption, power loss	
Type of voltage of supply voltage	DC
Supply voltage 1 from backplane bus	5 V
Relative symmetrical tolerance at 5 V with DC	5 %
Consumed current from backplane bus at 5 V for DC Typical	1.4 A
Resistive loss	8.6 W
Permitted ambient conditions	
Ambient temperature	
• during operating	0 ... 60 °C
• during storage	-40 ... +70 °C
• during transport	-40 ... +70 °C
• Comment	-
Relative humidity at 25 °C without condensation during operating maximum	95 %
Protection class IP	IP20

Order No.	6GK7 443-1EX30-0XE0
Product-type designation	CP 443-1
Design, dimensions and weight	
Module format	
Width	25 mm
Height	290 mm
Depth	210 mm
Net weight	0.7 kg
Product properties, functions, components general	
Number of modules	
• per CPU maximum	14
• note	max. 4 as PN IO ctrl.
Performance data	
<u>Performance data open communication</u>	
Number of possible connections for open communication by means of SEND/RECEIVE blocks maximum	64
Data volume	
• as user data per ISO connection for open communication by means of SEND/RECEIVE blocks maximum	8 Kibyte
• as user data per ISO on TCP connection for open communication by means of SEND/RECEIVE blocks maximum	8 Kibyte
• as user data per TCP connection for open communication by means of SEND/RECEIVE blocks maximum	8 Kibyte
• as user data per UDP connection for open IE communication by means of SEND/RECEIVE blocks maximum	2 Kibyte
Number of possible connections for open communication by means of T blocks maximum	64

Technical specifications (continued)

Order No.	6GK7 443-1EX30-0XE0
Product-type designation	CP 443-1
Data volume as user data per ISO on TCP connection for open communication by means of T blocks maximum	1 452 byte
Number of Multicast stations	-
Performance data S7 communication	
Number of possible connections for S7 communication	
• maximum	128
• with PG connections maximum	2
• with PG/OP connections maximum	-
• note	when using several CPUs
Performance data multi-protocol mode	
Number of active connections with multiprotocol mode	128
Performance data PROFINET communication as PN IO-Controller	
Product function PROFINET IO controller	Yes
Number of PN IO-Devices on PROFINET IO-Controller usable total	128
Number of PN IO IRT-Devices on PROFINET IO-Controller usable	64
Number of external PN IO lines with PROFINET per rack	4
Data volume	
• as useful data for input variables as PROFINET IO controller maximum	4 Kibyte
• as useful data for output variables with PROFINET IO controller maximum	4 Kibyte
• as useful data for input variables per PN IO device with PROFINET IO controller maximum	1 433 byte
• as useful data for output variables per PN IO device with PROFINET IO controller maximum	1 433 byte
• as user data for input variable per PN IO device per submodule as PROFINET IO controller maximum	240 byte
• as user data for output variables per PN IO device per submodule as PROFINET IO controller maximum	240 byte

Order No.	6GK7 443-1EX30-0XE0
Product-type designation	CP 443-1
Product functions management, configuration	
Product function MIB support	Yes
Protocol is supported	
• SNMP v1	Yes
• DCP	Yes
• LLDP	Yes
Configuration software required	STEP 7 V5.5 SP2 HF1 or higher, or STEP 7 V11.0
Identification & maintenance	
• I&M0 - device-specific information	-
• I&M1 - plant identification/location name	-
Product functions Diagnosis	
Product function Web-based diagnostics	Yes
Product functions switch	
Product feature switch	Yes
Product function	
• switch-managed	No
• for IRT PROFINET IO switch	Yes
• Configuration with STEP 7	Yes
Product functions Redundancy	
Product function	
• Ring redundancy	Yes
• Redundancy manager	Yes
• MRP redundancy protocol	Yes
Product functions Security	
Product function	
• ACL - IP-based	Yes
• switchoff of non-required services	Yes
• blocking of communication via physical ports	Yes
• log file for unauthorized access	No
Product functions Time	
Product function	
• SICLOCK support	Yes
• pass on time synchronization	Yes
Protocol is supported NTP	Yes

Ordering data

Order No.	Order No.
CP 443-1 communications processor For connecting SIMATIC S7-400 to Industrial Ethernet through TCP/IP, ISO and UDP; PROFINET IO Controller, MRP; integrated real-time switch ERTEC with two ports; 2 x RJ45 interface; S7 communication, open communication (SEND/RECEIVE) with FETCH/WRITE, with and without RFC 1006, DHCP, SNMP V2, diagnostics, multicast, access protection over IP access list, initialization over LAN 10/100 Mbit/s with electronic manual on DVD	6GK7 443-1EX30-0XE0
SOFTNET S7 for Industrial Ethernet Software for S7 and open communication, including OPC server, PG/OP communication and NCM PC, runtime software, software and electronic manual on CD-ROM, license key on a USB stick, Class A	6GK1 704-1CW08-2AA0
SOFTNET-IE S7 V8.2 for 32/64-bit: Windows 7 Professional/Ultimate; for 64-bit: Windows 2008 Server R2; German/English up to 64 connections • Single License for one installation	6GK1 704-1CW08-2AA0

SIMATIC S7-400

Communication

CP 443-1

Ordering data	Order No.	Ordering data	Order No.
SOFTNET-S7 Edition 2008 (V7.1) for Industrial Ethernet For 32-bit Windows XP Professional SP2/3; Windows 2003 Server R2, SP2; Windows Vista Business/Ultimate SP1; Windows 2008 Server; German/English up to 64 connections • Single License for one installation Software Update Service For 1 year with automatic extension; requirement: current software version Upgrade • From Edition 2006 to Edition 2008 or V8.1 • From V6.0, V6.1, V6.2 or V6.3 to Edition 2008 or V8.1	6GK1 704-1CW71-3AA0 6GK1 704-1CW00-3AL0 6GK1 704-1CW00-3AE0 6GK1 704-1CW00-3AE1	IE FC TP Standard Cable GP 2x2 4-core, shielded TP installation cable for connection to IE FC RJ45 outlet / IE FC RJ45 plug; PROFINET-compliant; with UL approval; <u>sold by the meter</u> max. length 1000 m, minimum order 20 m	6XV1 840-2AH10
SOFTNET-IE S7 Lean Edition V8.2 Up to eight connections • Single License for one installation	6GK1 704-1LW08-2AA0	Industrial Ethernet Switch SCALANCE X204-2 Industrial Ethernet switches with integral SNMP access, online diagnostics, copper cable diagnostics and PROFINET diagnostics for configuring line, star and ring topologies; four 10/100 Mbit/s RJ45 ports and two fiber-optic cable ports	6GK5 204-2BB10-2AA3
SOFTNET-S7 Lean Edition 2008 (V7.1) for Industrial Ethernet Up to eight connections • Single License for one installation Software Update Service For 1 year with automatic extension; requirement: current software version Upgrade • From Edition 2006 to Edition 2008 or V8.1 • From V6.0, V6.1, V6.2 or V6.3 to Edition 2008 or V8.1	6GK1 704-1LW71-3AA0 6GK1 704-1LW00-3AL0 6GK1 704-1LW00-3AE0 6GK1 704-1LW00-3AE1	IE FC RJ45 Plug 180 2x2 RJ45 plug connector for Industrial Ethernet with a rugged metal housing and integrated insulation-displacement/terminal contacts for connecting Industrial Ethernet FC installation cables; with a 180° cable outlet; for network components and CPs/CPU with Industrial Ethernet interface • 1 pack = 1 unit • 1 pack = 10 units • 1 pack = 50 units	6GK1 901-1BB10-2AA0 6GK1 901-1BB10-2AB0 6GK1 901-1BB10-2AE0
		IE FC Stripping Tool Preadjusted stripping tool for fast stripping of the Industrial Ethernet FC cables	6GK1 901-1GA00

6

Overview



ISO	TCP/UDP	PN	MRP	IT	IP-R	PG/OP	S7/S5
●	●	●	●	●	●	●	●

Communications processor for connecting a SIMATIC S7-400 to Industrial Ethernet networks, also as PROFINET IO controller or in SIMATIC H systems.

The CP supports:

- PG/OP communication
- S7 communication
- Open communication (SEND/RECEIVE)
- PROFINET communication
- IT communication
- Security functionality, firewall and VPN

The communications processor can also be used for redundant S7 communication in SIMATIC H systems and for fail-safe applications (PROFIsafe) in connection with an S7-400 F-CPU. In addition, the CP 443-1 Advanced provides e-mail functions and user-created Web pages, offering ideal support for maintenance and quality assurance. The Internet functions such as FTP even allow connection to the most diverse PC-based systems.

This CP is therefore the bridge between the field level and the management level for the S7-400. The CP 443-1 Advanced connects seamlessly to the security structures of the office and IT worlds.

Technical specifications

Order No.	6GK7 443-1GX30-0XE0
Product-type designation	CP 443-1 Advanced
Transmission rate	
Transfer rate	
• at the interface 1	10 ... 1 000 Mbit/s
• at the interface 2	10 ... 100 Mbit/s
Interfaces	
Number of electrical connections	
• at interface 1 in accordance with Industrial Ethernet	1
• at interface 2 in accordance with Industrial Ethernet	4
Design of electrical connection	
• at interface 1 in accordance with Industrial Ethernet	RJ45 port
• at interface 2 in accordance with Industrial Ethernet	RJ45 port
design of the removable storage C-PLUG	Yes
Supply voltage, current consumption, power loss	
Type of voltage of supply voltage	DC
Supply voltage 1 from backplane bus	5 V
Relative symmetrical tolerance at 5 V with DC	5 %
Consumed current from backplane bus at 5 V for DC Typical	1.8 A
Resistive loss	7.25 W

Order No.	6GK7 443-1GX30-0XE0
Product-type designation	CP 443-1 Advanced
Permitted ambient conditions	
Ambient temperature	
• during operating	0 ... 60 °C
• during storage	-40 ... +70 °C
• during transport	-40 ... +70 °C
• Comment	-
Relative humidity at 25 °C without condensation during operating maximum	95 %
Protection class IP	IP20
Design, dimensions and weight	
Module format	
Width	25 mm
Height	290 mm
Depth	210 mm
Net weight	0.7 kg
Product properties, functions, components general	
Number of modules	
• per CPU maximum	14
• note	max. 4 as PN IO ctrl.

SIMATIC S7-400

Communication

CP 443-1 Advanced

Technical specifications (continued)

Order No.	6GK7 443-1GX30-0XE0
Product-type designation	CP 443-1 Advanced
Performance data	
<u>Performance data open communication</u>	
Number of possible connections for open communication by means of SEND/RECEIVE blocks maximum	64
Data volume	
• as user data per ISO connection for open communication by means of SEND/RECEIVE blocks maximum	8 Kibyte
• as user data per ISO on TCP connection for open communication by means of SEND/RECEIVE blocks maximum	8 Kibyte
• as user data per TCP connection for open communication by means of SEND/RECEIVE blocks maximum	8 Kibyte
• as user data per UDP connection for open IE communication by means of SEND/RECEIVE blocks maximum	2 Kibyte
Number of possible connections for open communication by means of T blocks maximum	64
Data volume as user data per ISO on TCP connection for open communication by means of T blocks maximum	1 452 byte
Number of Multicast stations	-
<u>Performance data S7 communication</u>	
Number of possible connections for S7 communication	
• maximum	128
• with PG connections maximum	2
• with PG/OP connections maximum	-
• note	when using several CPUs
<u>Performance data multi-protocol mode</u>	
Number of active connections with multiprotocol mode	128
<u>Performance data IT functions</u>	
Number of possible connections	
• as client by means of FTP maximum	20
• as server	
- by means of FTP maximum	10
- by means of HTTP maximum	4
• as e-mail client maximum	1
Amount of data as useful data for e-mail maximum	8 Kibyte
Storage capacity of user memory	
• as flash memory file system	30 Mibyte
• as RAM	16 Mibyte
• additionally buffered as RAM via central backup battery	512 Kibyte
Number of possible write cycles flash memory cells	100 000

Order No.	6GK7 443-1GX30-0XE0
Product-type designation	CP 443-1 Advanced
Performance data	
<u>PROFINET communication as PN IO-Controller</u>	
Product function PROFINET IO controller	Yes
Number of PN IO-Devices on PROFINET IO-Controller usable total	128
Number of PN IO IRT-Devices on PROFINET IO-Controller usable	64
Number of external PN IO lines with PROFINET per rack	4
Data volume	
• as useful data for input variables as PROFINET IO controller maximum	8 Kibyte
• as useful data for output variables with PROFINET IO controller maximum	8 Kibyte
• as useful data for input variables per PN IO device with PROFINET IO controller maximum	1 433 byte
• as useful data for output variables per PN IO device with PROFINET IO controller maximum	1 433 byte
• as user data for input variable per PN IO device per submodule as PROFINET IO controller maximum	240 byte
• as user data for output variables per PN IO device per submodule as PROFINET IO controller maximum	240 byte
<u>Performance data PROFINET CBA</u>	
Number of remote connection partners with PROFINET CBA	64
Number of connections with PROFINET CBA total	600
Amount of data	
• as useful data for digital inputs with PROFINET CBA maximum	8 Kibyte
• as useful data for digital outputs in the case of PROFINET CBA max.	8 Kibyte
• as useful data for arrays and data types	
- in the case of acyclic transmission with PROFINET CBA maximum	8 Kibyte
- in the case of cyclic transmission with PROFINET CBA maximum	250 byte
- in the case of local interconnection with PROFINET CBA maximum	2 400 byte
<u>Performance data PROFINET CBA remote connection with acyclic transmission</u>	
Updating time of the remote interconnections in the case of acyclic transmission with PROFINET CBA	0.1 s
Number of remote connections to input variables with acyclic transmission with PROFINET CBA maximum	150
Number of remote connections to output variables with acyclic transmission with PROFINET CBA maximum	150

Technical specifications (continued)

Order No.	6GK7 443-1GX30-0XE0	Order No.	6GK7 443-1GX30-0XE0
Product-type designation	CP 443-1 Advanced	Product-type designation	CP 443-1 Advanced
Amount of data		Product functions management, configuration	
• as useful data for remote interconnections with input variables in the case of acyclic transmission with PROFINET CBA	8 Kibyte	Product function MIB support	Yes
• as useful data for remote interconnections with output variables in the case of acyclic transmission with PROFINET CBA	8 Kibyte	Protocol is supported	
		• SNMP v1	Yes
		• DCP	Yes
		• LLDP	Yes
<u>Performance data PROFINET CBA remote connection with cyclic transmission</u>		Configuration software	
Updating time of the remote interconnections in the case of acyclic transmission with PROFINET CBA	10 ms	• required	STEP 7 V5.5 SP2 HF1 or higher, or STEP 7 V11.0 or higher
Number of remote connections to input variables with cyclic transmission with PROFINET CBA maximum	250	• for PROFINET CBA required	SIMATIC iMap V3.0 SP1 and higher
Number of remote connections to output variables with cyclic transmission with PROFINET CBA maximum	250	Identification & maintenance	
		• I&M0 - device-specific information	-
		• I&M1 - plant identification/location name	-
		Product functions Diagnosis	
		Product function Web-based diagnostics	Yes
Amount of data		Product functions switch	
• as useful data for remote interconnections with input variables in the case of cyclic transmission with PROFINET CBA max.	2 000 byte	Product feature switch	Yes
• as useful data for remote interconnections with output variables in the case of cyclic transmission with PROFINET CBA maximum	2 000 byte	Product function	
		• switch-managed	No
		• for IRT PROFINET IO switch	Yes
		• Configuration with STEP 7	Yes
		Product functions Redundancy	
<u>Performance data PROFINET CBA HMI variables via PROFINET acyclic</u>		Product function	
Number of connectable HMI stations for HMI variables with acyclic transmission with PROFINET CBA	3	• Ring redundancy	Yes
Updating time of the HMI variables in the case of acyclic transmission with PROFINET CBA	500 ms	• Redundancy manager	Yes
Number of HMI variables with acyclic transmission with PROFINET CBA maximum	200	• MRP redundancy protocol	Yes
Amount of data as useful data for HMI variables in the case of acyclic transmission with PROFINET CBA maximum	8 Kibyte	Product functions Security	
		Design of the firewall	stateful inspection
<u>Performance data PROFINET CBA device-internal connections</u>		Product function with VPN connection	IPSec
Number of internal connections with PROFINET CBA maximum	300	Type of encryption algorithms with VPN connection	AES-256, AES-192, AES-128, 3DES-168, DES-56
Data volume of internal connections with PROFINET CBA maximum	2 400 byte	Type of authentication procedure with VPN connection	Preshared key (PSK), X.509v3 certificates
<u>Performance data PROFINET CBA connections to constants</u>		Type of hashing algorithms with VPN connection	MD5, SHA-1
Number of connections to constants with PROFINET CBA maximum	500	Number of possible connections for VPN connection	32
Amount of data as useful data for interconnections with constants in the case of PROFINET CBA maximum	4 000 byte	Product function	
		• password protection for Web applications	Yes
<u>Performance data PROFINET CBA PROFIBUS proxy functionality</u>		• ACL - IP-based	Yes
Product function with PROFINET CBA PROFIBUS proxy functionality	No	• ACL - IP-based for PLC/routing	Yes
		• switchoff of non-required services	Yes
		• blocking of communication via physical ports	Yes
		• log file for unauthorized access	No
		Product functions Time	
		Product function	
		• SICLOCK support	Yes
		• pass on time synchronization	Yes
		Protocol is supported NTP	Yes

SIMATIC S7-400

Communication

CP 443-1 Advanced

Ordering data

Order No.

Order No.

CP 443-1 Advanced communications processor

For connecting the SIMATIC S7-400 CPU to Industrial Ethernet:
 1 x 10/100/1000 Mbit/s;
 4 x 10/100 Mbit/s (IE SWITCH);
 RJ45 ports; ISO; TCP; UDP;
 PROFINET IO controller,
 S7 communication; open
 communication (SEND/RECEIVE);
 S7 routing; IP configuration via
 DHCP/block; IP Access Control List;
 time synchronization; expanded
 web diagnostics; Fast Startup;
 PROFINET support; IP routing;
 FTP; web server; e-mail;
 PROFINET CBA

- With security functionality (firewall and VPN)

6GK7 443-1GX30-0XE0

SOFTNET S7 for Industrial Ethernet

Software for S7 and open communication, including OPC server, PG/OP communication and NCM PC, runtime software, software and electronic manual on CD-ROM, license key on a USB stick, Class A

SOFTNET-IE S7 V8.2

For 32/64-bit
 Windows 7 Professional/Ultimate;
 For 64-bit:
 Windows 2008 Server R2;
 German/English

Up to 64 connections
 • Single License for one installation

6GK1 704-1CW08-2AA0

SOFTNET-S7 Edition 2008 (V7.1) for Industrial Ethernet

For 32-bit Windows XP Professional SP2/3; Windows 2003 Server R2, SP2; Windows Vista Business/Ultimate SP1; Windows 2008 Server; German/English

Up to 64 connections
 • Single License for one installation

6GK1 704-1CW71-3AA0

Software Update Service

For 1 year with automatic extension; requirement: current software version

6GK1 704-1CW00-3AL0

Upgrade

- From Edition 2006 to Edition 2008 or V8.1
- From V6.0, V6.1, V6.2 or V6.3 to Edition 2008 or V8.1

6GK1 704-1CW00-3AE0

6GK1 704-1CW00-3AE1

SOFTNET-IE S7 Lean Edition V8.2

Up to eight connections
 • Single License for one installation

6GK1 704-1LW08-2AA0

SOFTNET-S7 Lean Edition 2008 (V7.1) for Industrial Ethernet

Up to eight connections
 • Single License for one installation

6GK1 704-1LW71-3AA0

Software Update Service

For 1 year with automatic extension; requirement: current software version

6GK1 704-1LW00-3AL0

Upgrade

- From Edition 2006 to Edition 2008 or V8.1
- From V6.0, V6.1, V6.2 or V6.3 to Edition 2008 or V8.1

6GK1 704-1LW00-3AE0

6GK1 704-1LW00-3AE1

Accessories

IE FC TP Standard Cable GP 2x2 (type A)

4-core, shielded TP installation cable for connection to IE FC outlet RJ45/IE FC RJ45 plug; PROFINET-compatible; with UL approval; sold in meters, max. quantity 1000 m, minimum order 20 m

6XV1 840-2AH10

IE FC TP standard cable GP 4x2

8-core, shielded TP installation cable for connection to IE FC RJ45 Modular Outlet for universal application; with UL approval; sold by the meter, max quantity 1000 m, minimum order 20 m

6XV1 870-2E

6XV1 878-2A

- AWG22, for connection to IE FC RJ45 Modular Outlet
- AWG24, for connection to IE FC RJ45 Plug 4 x 2

IE FC RJ45 Plug 180 2x2

RJ45 plug connector for Industrial Ethernet with a rugged metal housing and integrated insulation-displacement/terminal contacts for connecting Industrial Ethernet FC installation cables; with a 180° cable outlet; for network components and CPs/CPU with Industrial Ethernet interface

- 1 pack = 1 unit
- 1 pack = 10 units
- 1 pack = 50 units

6GK1 901-1BB10-2AA0

6GK1 901-1BB10-2AB0

6GK1 901-1BB10-2AE0

IE FC RJ45 Plug 4 x 2

RJ45 plug connector for Industrial Ethernet (10/100/1000 Mbit/s) with a rugged metal enclosure and integrated insulation displacement contacts for connecting Industrial Ethernet FC installation cables; 180° cable outlet; for network components and CPs/CPU with Industrial Ethernet interface

- 1 pack = 1 unit
- 1 pack = 10 units
- 1 pack = 50 units

6GK1 901-1BB11-2AA0

6GK1 901-1BB11-2AB0

6GK1 901-1BB11-2AE0

Ordering data	Order No.	Order No.
IE FC Stripping Tool Preadjusted stripping tool for fast stripping of Industrial Ethernet FC cables	6GK1 901-1GA00	SIMATIC iMap V3.0 for configuring PROFINET CBA, Requirement: Windows 2000 Prof. with Service Pack 4 or later or Windows XP Prof. with Service Pack 1 or later or Windows 2003 Server with Service Pack 1 or later; on PG or PC with Pentium processor, min. 1 GHz; STEP 7 V5.3 or later with Service Pack 3, PN OPC Server V6.3 or later Available in: German, English, with electronic documentation <ul style="list-style-type: none"> • Single license • Software Update Service • Upgrade to V3.0, Single license
Industrial Ethernet Switch SCALANCE X204-2 with four 10/100 Mbit/s RJ45 ports and two fiber-optic cable ports	6GK5 204-2BB10-2AA3	
Industrial Ethernet Switch SCALANCE X308-2 2 x 1000 Mbit/s multimode fiber-optic cable ports (SC sockets), 1 x 10/100/1000 Mbit/s RJ45 port, 7 x 10/100 Mbit/s RJ45 ports; for glass fiber-optic cable (multimode) up to max. 750 m	6GK5 308-2FL00-2AA3	
		6ES7 820-0CC04-0YA5 6ES7 820-0CC01-0YX2 6ES7 820-0CC04-0YE5

SIMATIC S7-400

Communication

SCALANCE M87x UMTS router

Overview



- UMTS, EGPRS (Edge GPRS) and GPRS router for wireless IP communication of Industrial Ethernet-based PLCs over UMTS/GSM mobile wireless networks
- High data transfer rate thanks to UMTS
- Integrated security functions with firewall
- *SCALANCE M875*:
Use both as VPN server and as client (IPsec)

6

Technical specifications

Order No.	6GK5 873-0AA10-1AA2	6GK5 875-0AA10-1AA2
Product-type designation	SCALANCE M873	SCALANCE M875
Transmission rate		
Transfer rate		
• 1 for Industrial Ethernet	10 Mbit/s	10 Mbit/s
• 2 for Industrial Ethernet	100 Mbit/s	100 Mbit/s
• for GSM transmission	9 600 bit/s	9 600 bit/s
• with GPRS transmission		
- with downlink maximum	85.6 kbit/s	85.6 kbit/s
- with uplink maximum	85.6 kbit/s	42.8 kbit/s
• with eGPRS transmission		
- with downlink maximum	236.8 kbit/s	236.8 kbit/s
- with uplink maximum	236.8 kbit/s	118 kbit/s
• with UMTS transmission		
- with downlink maximum	3.6 Mbit/s	14.4 Mbit/s
- with uplink maximum	0.384 Mbit/s	5.76 Mbit/s
Interfaces		
Number of electrical connections		
• for network components and terminal equipment	1	2
• for external antenna(s)	1	2
• for power supply	1	1
Design of electrical connection		
• for network components and terminal equipment		
• for external antenna(s)	SMA antenna socket (50 ohms)	SMA antenna socket (50 ohms)
• for power supply	Terminal block	Terminal block
Inputs/outputs		
Number of electrical connections		
• for digital input signals	1	1
• for digital output signals	1	1
Design of electrical connection		
• for digital input signals	Terminal block	Terminal block
• for digital output signals	Terminal block	Terminal block

Technical specifications (continued)

Order No.	6GK5 873-0AA10-1AA2	6GK5 875-0AA10-1AA2
Product-type designation	SCALANCE M873	SCALANCE M875
WAN connection		
Type of mobile wireless network is supported GSM	Yes	Yes
Type of mobile wireless service is supported		
• GPRS	Yes	Yes
• eGPRS	Yes	Yes
Type of mobile wireless network is supported UMTS	Yes	Yes
Type of mobile wireless service is supported		
• HSDPA	Yes	Yes
• HSUPA	No	Yes
Operating frequency		
• for GSM transmission		
- 850 MHz	Yes	Yes
- 900 MHz	Yes	Yes
- 1800 MHz	Yes	Yes
- 1900 MHz	Yes	Yes
• for UMTS transmission		
- 800 MHz	No	Yes
- 850 MHz	Yes	Yes
- 900 MHz	No	No
- 1700 MHz	No	Yes
- 1900 MHz	Yes	Yes
- 2100 MHz	Yes	Yes
Type of GPRS time slot method Multislot Class 10	-	-
Supply voltage, current consumption, power loss		
Type of voltage of supply voltage	DC	DC
Supply voltage	24 V	24 V
• minimum	12 V	12 V
• maximum	30 V	30 V
Consumed current maximum	450 mA	450 mA
Active power loss typical	4 W	4 W
Permitted ambient conditions		
Ambient temperature		
• during operating	-20 ... +60 °C	-40 ... +75 °C
• during storage	-40 ... +70 °C	-40 ... +85 °C
Relative humidity at 25 °C during operating maximum	95 %	95 %
Protection class IP	IP20	IP20
Design, dimensions and weight		
Design	compact	compact
Depth	114 mm	114 mm
Height	99 mm	99 mm
Width	45 mm	45 mm
Net weight	280 g	280 g
Type of mounting 35 mm DIN rail mounting	-	-
Type of mounting	-	-

SIMATIC S7-400

Communication

SCALANCE M87x UMTS router

Technical specifications (continued)

Order No.	6GK5 873-0AA10-1AA2	6GK5 875-0AA10-1AA2
Product-type designation	SCALANCE M873	SCALANCE M875
Product properties, functions, components general		
Product function DynDNS client	Yes	Yes
Product functions management, configuration		
Product function		
• CLI	No	No
• web-based management	Yes	Yes
• MIB support	No	No
• TRAPs via email	No	No
Protocol is supported		
• Telnet	No	No
• HTTP	No	No
• HTTPS	Yes	Yes
Type of configuration	Web interface	Web interface
Product functions Diagnosis		
Product function		
• Statistics Packet Size	No	No
• Statistics packet type	No	No
• Error statistics	No	No
• SysLog	Yes	Yes
• Packet Filter Log	Yes	Yes
Product functions DHCP		
Product function		
• DHCP client	Yes	Yes
• DHCP server - internal network	Yes	Yes
Product functions Routing		
Router function		
• NAT (IP masquerading)	Yes	Yes
• Port Forwarding	Yes	Yes
• NAT traversal	Yes	Yes
• 1:1 NAT	Yes	Yes
• DNS cache	Yes	Yes
Product functions Security		
Design of the firewall		
Product function		
• Password protection	Yes	Yes
• packet filter	Yes	Yes
• Broadcast/Multicast/Unicast Limiter	-	-
• broadcast blocking	-	-
Suitability for installation Virtual Private Network	No	Yes
Product function with VPN connection	F	T
Number of possible connections for VPN connection	-	10
Number of network stations for internal network with VPN connection maximum	-	-
Type of authentication with Virtual Private Network PSK	No	Yes
Protocol will be supported IPsec tunnel and transport mode	No	Yes

Technical specifications (continued)

Order No.	6GK5 873-0AA10-1AA2	6GK5 875-0AA10-1AA2
Product-type designation	SCALANCE M873	SCALANCE M875
Key length		
• with IPsec DES with Virtual Private Network	-	56 bit
• 1 with IPsec AES with Virtual Private Network	-	128 bit
• 2 with IPsec AES with Virtual Private Network	-	192 bit
• 3 with IPsec AES with Virtual Private Network	-	256 bit
Type of Internet key exchange with Virtual Private Network main mode	No	Yes
Key length with IPsec 3DES with Virtual Private Network	-	168 bit
Type of Internet key exchange with Virtual Private Network quick mode	No	Yes
Type of packet authentication with Virtual Private Network	-	
IETF profile with Virtual Private Network X.509v3 certificate	No	Yes
Product functions Time		
Router function NTP	Yes	Yes
Standards, specifications, approvals		
Standard		
• for EMC	-	-
• for EMC from FM	-	-
• for hazardous zone	-	-
• for safety of CSA and UL	-	-
• for hazardous area of CSA and UL	-	-
• for emitted interference	EN55022 Class A	EN55022 Class A
• for interference immunity	EN 61000-6-2	EN 61000-6-2
Verification of suitability	EN 61000-6-2	EN 61000-6-2
• CE mark	Yes	Yes
• C-Tick	-	-
• E1 approval	Yes	Yes
• e1 approval	Yes	Yes
• Railway application in accordance with EN 50155	No	Yes

SIMATIC S7-400

Communication

SCALANCE M87x UMTS router

Ordering data

Order No.

Order No.

SCALANCE M 87x UMTS router

UMTS router for wireless IP communication between Industrial Ethernet-based programmable controllers via UMTS/GSM mobile radio networks; EGPRS Multislot Class 12

- **SCALANCE M873¹⁾**
with integral firewall;
1 x RJ45 port, 1 x antenna connection
- **SCALANCE M875¹⁾**
with integral firewall and VPN with IPsec;
2 x RJ45 ports, 2 x antenna connections

6GK5 873-0AA10-1AA2

6GK5 875-0AA10-1AA2

Accessories

IE FC RJ45 Plug 180

RJ45 plug-in connector for Industrial Ethernet with a rugged metal enclosure and integrated insulation displacement contacts for connecting Industrial Ethernet FC installation cables; with 180° cable outlet; for network components and CPs/CPUs with Industrial Ethernet interface

- 1 pack = 1 unit
- 1 pack = 10 units
- 1 pack = 50 units

6GK1 901-1BB10-2AA0

6GK1 901-1BB10-2AB0

6GK1 901-1BB10-2AE0

ANT794-4MR antenna

Omnidirectional antenna for GSM (2G) and UMTS (3G) networks; weather-resistant for indoor and outdoor use; 5 m cable with fixed connection to antenna; SMA connector; including mounting bracket, screws, wall plugs

6NH9 860-1AA00

SCALANCE S Industrial Security Modules

For protection of programmable controllers and automation networks, and for safeguarding of industrial communication; configuring tool and electronic manual on CD-ROM; German, English, French, Italian, Spanish

- **SCALANCE S612**
uses the stateful inspection firewall to protect network segments against unauthorized access; protects up to 32 devices up to 64 VPN tunnels simultaneously
- **SCALANCE S623²⁾**
uses the stateful inspection firewall to protect network segments against unauthorized access; protects up to 64 devices and up to 128 VPN tunnels simultaneously; enhanced temperature range (-20 to +70 °C)

6GK5 612-0BA10-2AA3

6GK5 623-0BA10-2AA3

CP 343-1 Advanced

For connecting the SIMATIC S7-300 CPU to Industrial Ethernet; 1 x 10/100/1000 Mbit/s; 2 x 10/100 Mbit/s (IE switch); RJ45 ports; TCP; UDP; ISO; PROFINET IO-Controller and Device, S7 communication (client + server); open communication (SEND/RECEIVE); S7 routing; IP configuration via DHCP/block; extended Web diagnostics; time synchronization; IP Access Control List; IP routing; FTP; e-mail; PROFINET CBA; C-Plug; mit Security (Firewall + VPN) und PROFInergy (Controller + Device)

6GK7 343-1GX31-0XE0

CP 443-1 Advanced

for connecting the SIMATIC S7-400 CPU to Industrial Ethernet; 1 x 10/100/1000 Mbit/s; 4 x 10/100 Mbit/s (IE SWITCH); RJ45 ports; ISO; TCP; UDP; PROFINET IO controller, S7 communication; open communication (SEND/RECEIVE); S7 routing; IP configuration via DHCP/block; IP Access Control List; time synchronization; expanded Web diagnostics; Fast Startup; PROFInergy support; IP routing; FTP; Web server; e-mail; PROFINET CBA; mit Security (Firewall/VPN)

6GK7 443-1GX30-0XE0

IE TP Cord RJ45/RJ45

TP cable 4 x 2 with 2 RJ45 connectors

- 0.5 m
- 1 m
- 2 m
- 6 m
- 10 m

6XV1 870-3QE50

6XV1 870-3QH10

6XV1 870-3QH20

6XV1 870-3QH60

6XV1 870-3QN10

¹⁾ Please note national approvals under www.siemens.com/wireless-approvals

Overview



ISO	TCP/UDP	PN	MRP	IT	IP-R	PG/OP	S7/S5
●	●	●	●	●		●	●

- Connection of SIMATIC S7-400 to Industrial Ethernet
 - 2 x RJ45 interface for 10/100 Mbit/s full/half-duplex connection with auto-sensing/auto-negotiation and auto-crossover function
 - Integrated real-time switch ERTEC with two ports
 - Multi-protocol operation for ISO, TCP/IP, UDP and PROFINET IO protocols
 - Adjustable Keep Alive function
- Communication services:
 - Open communication (ISO, TCP/IP, and UDP)
 - PROFINET IO Controller with real-time properties RT and IRT
 - PG/OP communication: Cross-network by means of S7 routing
 - S7 communication
- Media redundancy (MRP); the CP supports the media redundancy procedure MRP within an Ethernet network with ring topology.
- Multicast for UDP
- Access protection via configurable access list
- Support for fail-safe programmable controllers together with SIMATIC S7-400 CPU 416F-3PN/DP
- Module replacement without PG
- Operation in the SIMATIC H system for redundant S7-communication
- Configuration with STEP 7
- Diagnostics possibilities in STEP 7 and via web browser
- Automatic CPU-clock setting via Industrial Ethernet with NTP or SIMATIC procedure
- Integration of network management systems via SNMP (MIB II diagnostic information)

Note:

SIPLUS extreme products are based on Siemens Industry standard products. The contents listed here were taken from the respective standard products. SIPLUS extreme specific information was added.

SIPLUS CP 443-1

Order No.	6AG1 443-1EX20-4XE0
Order number based on	6GK7 443-1EX20-0XE0
Ambient temperature range	0 ... +60 °C
Conformal coating	Coating of the printed circuit boards and the electronic components
Technical data	The technical data of the standard product applies, except for the ambient conditions
Ambient conditions	
Relative humidity	100%, condensation/frost permissible. No commissioning if condensation present.
Biologically active substances, compliance with EN 60721-3-3	Class 3B2 mold spores, fungal spores (excluding fauna). The supplied plug covers must remain in place over the unused interfaces during operation!
Chemically active substances, compliance with EN 60721-3-3	Class 3C4 incl. salt spray in accordance with EN60068-2-52 (degree of severity 3). The supplied plug covers must remain in place over the unused interfaces during operation!
Mechanically active substances, compliance with EN 60721-3-3	Class 3S4 incl. sand, dust. The supplied plug covers must remain in place over the unused interfaces during operation!
Air pressure (depending on the highest positive temperature range specified)	1080 ... 795 hPa (-1000 ... +2000 m) see ambient temperature range 795 ... 658 hPa (+2000 ... +3500 m) derating 10 K 658 ... 540 hPa (+3500 ... +5000 m) derating 20 K

For technical documentation on SIPLUS, see: www.siemens.com/siplus-extreme

Ordering data

SIPLUS CP 443-1 communications processor

(medial exposure)

For connecting SIMATIC S7-400 to Industrial Ethernet through TCP/IP, ISO and UDP; PROFINET IO Controller, MRP; integrated real-time switch ERTEC with two ports; 2 x RJ45 interface; S7 communication, open communication (SEND/RECEIVE) with FETCH/WRITE, with and without RFC 1006, DHCP, SNMP V2, diagnostics, multicast, access protection over IP access list, initialization over LAN 10/100 Mbit/s with electronic manual on DVD

Accessories

Order No.

6AG1 443-1EX20-4XE0

See SIMATIC CP 443-1, page 6/113

SIMATIC S7-400

SIPLUS communication

SIPLUS CP 443-1 Advanced

Overview



ISO	TCP/UDP	PN	MRP	IT	IP-R	PG/OP	S7/S5
●	●	●	●	●	●	●	●

- Connection of SIMATIC S7-400 to Industrial Ethernet
 - Multi-protocol operation for ISO, TCP/IP, UDP and PROFINET IO protocols
 - Adjustable keep-alive function
- Two separate interfaces (integrated network separation):
 - Gigabit interface with one RJ45 port with 10/100/1 000 Mbit/s, full/half-duplex with auto-sensing capability
 - PROFINET interface with four RJ45 ports with 10/100 Mbit/s, full/half duplex with autosensing and autocrossover functionality via integrated 4-port switch
- Communication services via both interfaces
 - Open communication (ISO, TCP/IP and UDP), multicast with UDP, including routing between both interfaces
 - PG/OP communication:
 - Cross-network by means of S7 routing
 - S7 communication (client, server, multiplexing) including routing between both interfaces
 - IT communication:
 - HTTP communication supports access to process data via own Web pages;
 - e-mail client function, sending of e-mails with authentication directly from user program;
 - FTP communication supports program-controlled FTP client communication;
 - access to data blocks through FTP server
- Communication services via PROFINET interface
 - PROFINET IO controller with real-time properties (RT and IRT)
 - PROFINET CBA
 - IP address assignment via DHCP, simple PC tool or via the user program (e.g. HMI)
 - Support of the prioritized startup of PROFINET IO devices
 - Configuration with STEP 7
- Media redundancy (MRP); the CP supports the media redundancy procedure MRP within an Ethernet network with ring topology.
- Access protection by means of configurable IP access list
- Module replacement without programming device; all information is stored on the C-PLUG (also file system for IT functions)

- Extensive diagnostic functions for all modules in the rack
- Integration into network management systems through the support of SNMP V1 MIB-II
- Operation in the SIMATIC H system for redundant S7-communication
- Operation in fail-safe applications (PROFIsafe) in combination with SIMATIC S7-400 CPU 416F

Note:

SIPLUS extreme products are based on Siemens Industry standard products. The contents listed here were taken from the respective standard products. SIPLUS extreme specific information was added.

SIPLUS CP 443-1 Advanced	
Order No.	6AG1 443-1GX20-4XE0
Order number based on	6GK7 443-1GX20-0XE0
Ambient temperature range	0 ... +60 °C
Conformal coating	Coating of the printed circuit boards and the electronic components
Technical data	The technical data of the standard product applies, except for the ambient conditions

Ambient conditions

Relative humidity	100%, condensation/frost permissible. No commissioning if condensation present.
Biologically active substances, compliance with EN 60721-3-3	Class 3B2 mold and fungal spores (excluding fauna). The supplied plug covers must remain in place over the unused interfaces during operation!
Chemically active substances, compliance with EN 60721-3-3	Class 3C4 incl. salt spray in accordance with EN60068-2-52 (degree of severity 3). The supplied plug covers must remain in place over the unused interfaces during operation!
Mechanically active substances, compliance with EN 60721-3-3	Class 3S4 incl. sand, dust. The supplied plug covers must remain in place over the unused interfaces during operation!
Air pressure (depending on the highest positive temperature range specified)	1 080 ... 795 hPa (-1 000 ... +2 000 m) see ambient temperature range 795 ... 658 hPa (+2 000 ... +3 500 m) derating 10 K 658 ... 540 hPa (+3 500 ... +5 000 m) derating 20 K

For technical documentation on SIPLUS, see:
www.siemens.com/siplus-extreme

Ordering data	Order No.	Accessories	Order No.
<p>SIPLUS CP 443-1 Advanced communications processor</p> <p>(medial exposure)</p> <p>For the connection of SIMATIC S7-400 to Industrial Ethernet; PROFINET IO Controller with RT and IRT, MRP, PROFINET CBA, TCP/IP, ISO and UDP; S7 communication, open communication (SEND/RECEIVE) with FETCH/WRITE, with and without RFC 1006, diagnostic expansions, multicast, clock synchronization via SIMATIC procedure or NTP; access protection via IP access list, FTP client/server, HTTP server, HTML diagnostics, SNMP, DHCP, e-mail, data storage on C-PLUG;</p> <p>PROFINET interface: 4 x RJ45 (10/100 Mbit/s) over switch; Gigabit interface: 1 x RJ45 (10/100/1000 Mbit/s); with electronic manual on DVD</p> <ul style="list-style-type: none"> • For use with SIMATIC S7-400 CPU, V5.2 and higher 	<p>6AG1 443-1GX20-4XE0</p>	<p>See SIMATIC CP 443-1 Advanced, page 6/118</p>	

SIMATIC S7-400

Connection methods

Front connectors

Overview



- For simple and user-friendly connection of sensors and actuators
- For retaining the wiring when replacing modules
- With coding to avoid mistakes when replacing modules

Ordering data

Order No.

Front connectors

48-pin for signal modules, function modules; 1 unit

- With screw contacts
- With spring-loaded terminals
- With crimp contacts

6ES7 492-1AL00-0AA0

6ES7 492-1BL00-0AA0

6ES7 492-1CL00-0AA0

48-pin for signal modules, function modules; 84 units per pack

- With screw contacts
- With crimp contacts

6ES7 492-1AL00-1AB0

6ES7 492-1CL00-1AB0

for 6ES7 431-7KF00-0AB0; spare part, included in scope of delivery; 1 piece

6ES7 431-7KF00-6AA0

Crimp contacts

6XX3 070

250 units

Crimping tool

6XX3 071

for crimping the contacts

Front cover for front connector

6ES7 492-2XL00-0AA0

6 units

Connection terminal for modules

6ES7 490-1BA00-0AA0

6 units

SIMATIC Manual Collection

6ES7 998-8XC01-8YE0

Electronic manuals on DVD, multilingual: LOGO!, SIMADYN, SIMATIC bus components, SIMATIC C7, SIMATIC distributed I/O, SIMATIC HMI, SIMATIC Sensors, SIMATIC NET, SIMATIC PC Based Automation, SIMATIC PCS 7, SIMATIC PG/PC, SIMATIC S7, SIMATIC Software, SIMATIC TDC

SIMATIC Manual Collection update service for 1 year

6ES7 998-8XC01-8YE2

Current "Manual Collection" DVD and the three subsequent updates

Overview

Wiring of SIMATIC S7 I/O modules with the sensors/actuators is a significant factor with respect to time/cost overhead, configuring, control cabinet installation, procurement and ease of service.

With SIMATIC TOP connect system cabling, it is simple and quick to establish a reliable connection for your SIMATIC S7-300/400.

With the TIA Selection Tool, a mouse click is all that is required to configure the connection from the SIMATIC S7 module to the I/O. The program automatically checks for plausibility and generates a parts list for the selected connection components that can then be ordered in the Industry Mall.

Further information can be found on the Internet at

www.siemens.com/tia-selection-tool

Design

The flexible connection lets you quickly connect sensors and actuators inside the control cabinet with the SIMATIC S7-400.

The flexible connection consists of:

- Front connector with screw-type or crimp connection
- Front connector with fixed single cores
- Single cores also available with UL/CSA-certified cores

The blue wires are numbered sequentially and can be routed direct to each element in the control cabinet. The numbering of the single cores corresponds to the coding of the front connector contacts.

In comparison to conventional single wiring, there is a cost saving of 50% for assembly, since the single cores that have already been checked on the connector are fixed.

Thus no complex pre-assembly of up to two times 46 single cores per module is necessary.

SIMATIC S7-400

Connection methods

Flexible connection

Overview



The flexible connection guarantees a fast and direct connection from the input/output modules of the SIMATIC S7-300/400 to the individual elements in the cabinet.

Already attached single cores reduce the wiring effort.

The core cross-sections of 0,5 mm² also allow higher currents.

Technical specifications

Front connector with single cores	
Rated operating voltage	24 V DC
Max. permissible continuous current with simultaneous load on all cores	1.0 A
Permissible ambient temperature	0 to +60 C
Core type	H05V-K or with UL style 1007/1569 CSA TR64
Number of cores	46
Core cross-section	0.5 mm ² , Cu
Bundle diameter in mm	approx. 17
Core color	Blue, RAL 5010
Designation of cores	Numbered 3 to 48 (adapter contact = core number)
Assembly	Screw-type or crimp contacts

Ordering data

Order No.

Front connector with single cores for 32-channel module SIMATIC S7-400, 46 x 0.5 mm²

Core type H05V-K

Screw connection

Packaging unit: 1 unit

Length:

- 2.5 m
- 3.2 m
- 5 m
- Custom lengths

6ES7 922-4BC50-0AD0
6ES7 922-4BD20-0AD0
6ES7 922-4BF00-0AD0
 on request

Packaging unit: 5 units

Length:

- 2.5 m
- 3.2 m
- 5 m

6ES7 922-4BC50-5AD0
6ES7 922-4BD20-5AD0
6ES7 922-4BF00-5AD0

Crimp connection

Packaging unit: 1 unit

Length:

- 2.5 m
- 3.2 m
- 5 m
- Custom lengths

6ES7 922-4BC50-0AE0
6ES7 922-4BD20-0AE0
6ES7 922-4BF00-0AE0
 on request

Packaging unit: 5 units

Length:

- 2.5 m
- 3.2 m
- 5 m

6ES7 922-4BC50-5AE0
6ES7 922-4BD20-5AE0
6ES7 922-4BF00-5AE0

Core type UL/CSA-certified

Screw-type version

Packaging unit: 1 unit

- 3.2 m
- 5 m
- Custom lengths

6ES7 922-4BD20-0UD0
6ES7 922-4BF00-0UD0
 on request

Overview

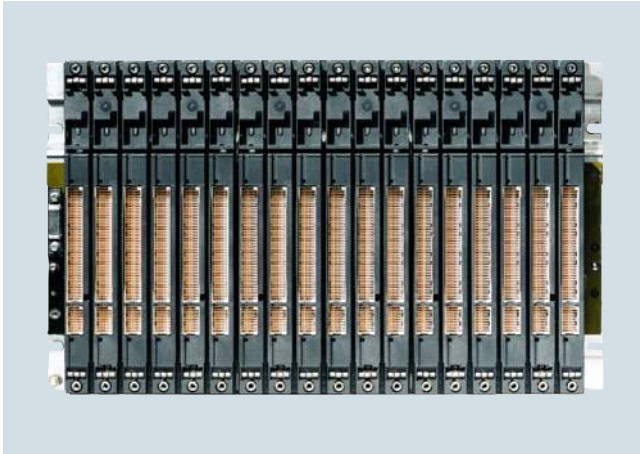

- The basic mechanical framework of the SIMATIC S7-400/S7-400H
- For accommodating the modules, supplying them with operating voltage and connecting them via the backplane bus
- Several versions for configuring central controllers and expansion racks

UR1 (Universal Rack)

- For setting up central controllers and expansion units
- For holding up to 18 modules
- Also suitable for S7-400H
- Also available as aluminum rack

UR2 (Universal Rack)

- For setting up central controllers and expansion units
- For holding up to 9 modules
- Also suitable for S7-400H.
- Also available as aluminum rack

CR2 (Central Rack)

- For setting up central controllers
- For holding up to 18 modules
- Segmented rack:
For operating two mutually independent S7-400 CPUs without S7-400 Multicomputing, but with communication between the CPUs over the backplane bus (C bus). Both CPUs can address their own local I/O modules (segmented P bus).

CR3 (Central Rack)

- For configuring central racks
- Optimized for distributed automation solutions due to holding up to 4 modules

UR2-H

- For configuring a complete S7-400H system in one subrack
- Also suitable for S7-400:
Operation of 2 separate CPUs with their own I/O (separate P and C buses)
- Can also be used as an expansion unit
- For holding up to 18 modules
- Also available as aluminum rack

ER1 (Extension Rack)

- For setting up expansion units economically
- For holding up to 18 modules with restricted functionality
- Also suitable for S7-400H
- Also available as aluminum rack

ER2 (Extension Rack)

- For setting up expansion units economically
- For holding up to 9 modules with restricted functionality
- Also suitable for S7-400H
- Also available as aluminum rack

Technical specifications

	6ES7 400-1TA01-0AA0	6ES7 400-1TA11-0AA0	6ES7 400-1JA01-0AA0	6ES7 400-1JA11-0AA0	6ES7 401-2TA01-0AA0	6ES7 401-1DA01-0AA0
Hardware configuration						
Number of single-width slots, max.	18	18	9	9	18; 2 segments with 8 or 10 slots	4
Rack						
• Communication bus	Yes	Yes	Yes	Yes	Yes	Yes
• P bus	Yes	Yes	Yes	Yes	Yes	Yes
Dimensions						
Width	482.5 mm	482.5 mm	257.5 mm	257.5 mm	482.5 mm	130 mm
Height	290 mm	290 mm	290 mm	290 mm	290 mm	290 mm
Depth	27.5 mm	27.5 mm	27.5 mm	27.5 mm	27.5 mm	27.5 mm
Weight						
Weight, approx.	4 200 g	3 000 g	2 200 g	1 500 g	4 200 g	750 g

SIMATIC S7-400

Racks

Racks

Technical specifications (continued)

	6ES7 400-2JA00-0AA0	6ES7 400-2JA10-0AA0	6ES7 403-1TA01-0AA0	6ES7 403-1TA11-0AA0	6ES7 403-1JA01-0AA0	6ES7 403-1JA11-0AA0
Hardware configuration						
Number of single-width slots, max.	18	18	18	18	9	9
Rack						
• Communication bus	Yes	Yes				
• P bus	Yes	Yes	Yes	Yes	Yes	Yes
Dimensions						
Width	482.5 mm	482.5 mm	482.5 mm	482.5 mm	257.5 mm	257.5 mm
Height	290 mm	290 mm	290 mm	290 mm	290 mm	290 mm
Depth	27.5 mm	27.5 mm	27.5 mm	27.5 mm	27.5 mm	27.5 mm
Weight						
Weight, approx.	4 200 g	3 000 g	4 200 g	2 500 g	2 200 g	1 250 g

Ordering data

Order No.

Order No.

UR1 rack for central controllers and expansion units, 18 slots	6ES7 400-1TA01-0AA0	UR2-H rack for split CCs, 18 slots	6ES7 400-2JA00-0AA0
UR1 aluminum rack for central controllers and expansion units, 18 slots	6ES7 400-1TA11-0AA0	UR2-H aluminum rack for split CCs, 18 slots	6ES7 400-2JA10-0AA0
UR2 rack for central controllers and expansion units, 9 slots	6ES7 400-1JA01-0AA0	ER1 rack for expansion units, P bus only, 18 slots	6ES7 403-1TA01-0AA0
UR2 aluminum rack for central controllers and expansion units, 9 slots	6ES7 400-1JA11-0AA0	ER1 aluminum rack for expansion units, P bus only, 18 slots	6ES7 403-1TA11-0AA0
CR2 rack for segmented central controllers, 18 slots, 2 local segments	6ES7 401-2TA01-0AA0	ER2 rack for expansion units, P bus only, 9 slots	6ES7 403-1JA01-0AA0
CR3 rack for central controllers and expansion units, 4 slots; optimized for distributed automation solutions	6ES7 401-1DA01-0AA0	ER2 aluminum rack for expansion units, P bus only, 9 slots	6ES7 403-1JA11-0AA0
		Slot cover 10 units (spare part)	6ES7 490-1AA00-0AA0

6

Overview



- Fans for the SIMATIC S7-400
- Necessary when using modules that generate an extremely large amount of heat

Technical specifications

	6ES7 408-1TA01-0XA0	6ES7 408-1TB00-0XA0
Supply voltage		
24 V DC	Yes	
permissible range, lower limit (DC)	19.2 V	
permissible range, upper limit (DC)	30 V	
120 V AC		Yes
230 V AC		Yes
Line frequency		
• Frequency of the supply voltage		63 Hz
Input current		
Inrush current, typ.	0.9 A; at 24 V	0.6 A at rated voltage 230 VAC; 1.15 A at rated voltage 120 VAC
Power losses		
Power loss, max.	11 W	20 W
Digital outputs		
Relay outputs		
• Rated input voltage of relay coil L+ (DC)	24 V	24 V
• Switching capacity of contacts		
- Switching frequency/contacts/at ohmic load/maximum	200 mA	200 mA
Dimensions		
Width	482.5 mm	482.5 mm
Height	109.5 mm	109.5 mm
Depth	235 mm	235 mm
Weight		
Weight, approx.	1.6 kg	2 kg

Ordering data

Fan subassembly

for all racks;
Supply voltage

24 V DC
120 / 230 V AC

Dust filter

10 pieces

Order No.

6ES7 408-1TA01-0XA0

6ES7 408-1TB00-0XA0

6ES7 408-1TA00-7AA0

Replacement fan

Spare part

Cable duct

Same design as fan subassembly,
but without fans or electronic units

Order No.

6ES7 408-1TA00-6AA0

6ES7 408-0TA00-0AA0

SIMATIC S7-400

SIPLUS racks

SIPLUS racks

Overview

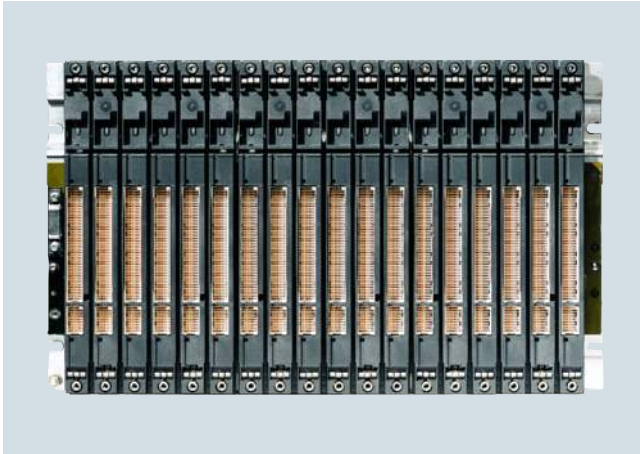

- The mechanical basic structure of SIPLUS S7-400/S7-400H
- For accommodating the modules, operating voltage supply, and connection of the modules via a backplane bus
- Several versions for setting up central controllers and expansion units
- SIPLUS rack material: Aluminum

Note:

SIPLUS extreme products are based on Siemens Industry standard products. The contents listed here were taken from the respective standard products. SIPLUS extreme-specific information was added.

6

SIPLUS S7-400 rack	6AG1 400-1JA11-7AA0	6AG1 400-1TA11-7AA0	6AG1 400-2JA10-4AA0	6AG1 400-2JA10-7AA0
Order No.	6AG1 400-1JA11-7AA0	6AG1 400-1TA11-7AA0	6AG1 400-2JA10-4AA0	6AG1 400-2JA10-7AA0
Order No. based on	6ES7 400-1JA11-0AA0	6ES7 400-1TA11-0AA0	6ES7 400-2JA10-0AA0	6ES7 400-2JA10-0AA0
Ambient temperature range	-25 ... +70 °C	-25 ... +70 °C	0 ... +60 °C	-25 ... +70 °C
Conformal coating	Coating of the printed circuit boards and the electronic components			
Technical data	The technical data of the standard product applies, except for the ambient conditions			
Ambient conditions				
Relative humidity	100%, condensation/frost permissible. No commissioning if condensation present.			
Biologically active substances, compliance with EN 60721-3-3	Class 3B2 mold and fungal spores (excluding fauna). The supplied plug covers must remain in place over the unused interfaces during operation!			
Chemically active substances, compliance with EN 60721-3-3	Class 3C4 incl. salt spray in accordance with EN60068-2-52 (degree of severity 3). The supplied plug covers must remain in place over the unused interfaces during operation!			
Mechanically active substances, compliance with EN 60721-3-3	Class 3S4 incl. sand, dust. The supplied plug covers must remain in place over the unused interfaces during operation!			
Air pressure (depending on the highest positive temperature range specified)	1080 ... 795 hPa (-1000 ... +2000 m) see ambient temperature range 795 ... 658 hPa (+2000 ... +3500 m) derating 10 K 658 ... 540 hPa (+3500 ... +5000 m) derating 20 K			

For further technical documentation on SIPLUS, see:
www.siemens.com/siplus-extreme

Ordering data	Order No.	Order No.
SIPLUS S7-400 rack (extended temperature range and medial exposure)		
Ambient temperature range -25 ... +70 °C		Ambient temperature range 0 ... +60 °C
UR1 aluminum rack for central controllers and expansion units, 18 slots	6AG1 400-1TA11-7AA0	UR2-H aluminum rack for central controllers and expansion units, 9 slots
UR2 aluminum rack for central controllers and expansion units, 9 slots	6AG1 400-1JA11-7AA0	6AG1 400-2JA10-4AA0
UR2-H aluminum rack for central controllers and expansion units, 9 slots	6AG1 400-2JA10-7AA0	Accessories See SIMATIC rack S7-400, page 6/132

Overview



- Send interface module for central expansion to 5 m
- Transmission of P and K bus
- Can be plugged into the central controller
- Up to 8 expansion racks can be connected (up to 4 per interface)
- Can be used exclusively with IM 461-0

Technical specifications

6ES7 460-0AA01-0AB0	
Input current	
from backplane bus 5 V DC, max.	140 mA
Power losses	
Power loss, max.	700 mW
Hardware configuration	
Cable length between first and last interface module, max.	5 m
Dimensions	
Width	25 mm
Height	290 mm
Depth	217 mm
Weight	
Weight, approx.	600 g

Ordering data

Ordering data	Order No.
IM 460-0 interface module	6ES7 460-0AA01-0AB0
Send interface module for central connection up to 5 m; with C bus transmission	
468-1 connecting cable	
between IM 460-0 and IM 461-0; IM 460-3 and IM 461-3	
0.75 m	6ES7 468-1AH50-0AA0
1.5 m	6ES7 468-1BB50-0AA0
5 m	6ES7 468-1BF00-0AA0

SIMATIC S7-400

Interface modules

IM 461-0

Overview



- Receive interface for centralized expansion up to 5 m
- Transmission of P and K bus
- Can be plugged into expansion rack
- To be used exclusively with IM 460-0

Technical specifications

6ES7 461-0AA01-0AA0	
Input current	
from backplane bus 5 V DC, max.	290 mA
Power losses	
Power loss, max.	1 450 mW
Hardware configuration	
Cable length between first and last interface module, max.	5 m
Dimensions	
Width	25 mm
Height	290 mm
Depth	217 mm
Weight	
Weight, approx.	610 g

Ordering data

Ordering data	Order No.
IM 461-0 interface module	6ES7 461-0AA01-0AA0
Receive interface module for central connection up to 5 m; with C bus transmission	
468-1 connecting cable	
between IM 460-0 and IM 461-0; IM 460-3 and IM 461-3	
0.75 m	6ES7 468-1AH50-0AA0
1.5 m	6ES7 468-1BB50-0AA0
5 m	6ES7 468-1BF00-0AA0
Terminating connector	6ES7 461-0AA00-7AA0
for IM 461-0	

Overview



- Send interface module for central expansion to 1.5 m
- Transmission of P bus
- With voltage supply for expansion units
- Can be plugged into the central controller
- Up to 2 expansion racks can be connected (up to 1 per interface)
- Can be used exclusively with IM 461-1

Technical specifications

6ES7 460-1BA01-0AB0	
Input current	
from backplane bus 5 V DC, max.	85 mA
Power losses	
Power loss, max.	425 mW
Hardware configuration	
Cable length between first and last interface module, max.	1.5 m
Dimensions	
Width	25 mm
Height	290 mm
Depth	217 mm
Weight	
Weight, approx.	600 g

Ordering data

Ordering data	Order No.
IM 460-1 interface module	6ES7 460-1BA01-0AB0
Send interface module for central connection up to 1.5 m; with 5 V power supply, without C bus transmission	
468-3 connecting cable	
between IM 460-1 and IM 461-1	
0.75 m	6ES7 468-3AH50-0AA0
1.5 m	6ES7 468-3BB50-0AA0

SIMATIC S7-400

Interface modules

IM 461-1

Overview



- Receive interface for central expansion up to 1.5 m
- Transmission of P bus
- With voltage supply for expansion racks
- Can be plugged into expansion rack
- Can be used exclusively with IM 460-1

Technical specifications

6ES7 461-1BA01-0AA0	
Input current	
from backplane bus 5 V DC, max.	120 mA
Power losses	
Power loss, max.	600 mW
Hardware configuration	
Cable length between first and last interface module, max.	1.5 m
Dimensions	
Width	25 mm
Height	290 mm
Depth	217 mm
Weight	
Weight, approx.	610 g

Ordering data

Ordering data	Order No.
IM 461-1 interface module	6ES7 461-1BA01-0AA0
Receive IM for central coupling up to max. 1.5 m; without C bus transfer	
468-3 connecting cable	
For connecting IM 460-1 and IM 461-1	
0.75 m	6ES7 468-3AH50-0AA0
1.5 m	6ES7 468-3BB50-0AA0

Overview



- Send interface module for distributed expansion to 102 m
- Transmission of K and P bus
- Can be plugged into the central controller
- Up to 8 expansion racks can be connected (up to 4 per interface)
- Can be used exclusively with IM 461-3

Technical specifications

6ES7 460-3AA01-0AB0	
Input current from backplane bus 5 V DC, max.	1 550 mA
Power losses Power loss, max.	7 750 mW
Hardware configuration Cable length between first and last interface module, max.	102.25 m
Dimensions	
Width	25 mm
Height	290 mm
Depth	217 mm
Weight Weight, approx.	630 g

Ordering data

Ordering data	Order No.
IM 460-3 interface module Send interface module for distributed connection up to 102 m; with C bus transmission	6ES7 460-3AA01-0AB0
468-1 connecting cable between IM 460-3 and IM 461-3	
0.75 m	6ES7 468-1AH50-0AA0
1.5 m	6ES7 468-1BB50-0AA0
5 m	6ES7 468-1BF00-0AA0
10 m	6ES7 468-1CB00-0AA0
25 m	6ES7 468-1CC50-0AA0
50 m	6ES7 468-1CF00-0AA0
100 m	6ES7 468-1DB00-0AA0

SIMATIC S7-400

Interface modules

IM 461-3

Overview



- Receive interface for distributed expansion up to 102 m
- Transmission of data from the P-bus and C-bus
- Can be plugged into expansion rack
- To be used exclusively with IM 460-3

Technical specifications

6ES7 461-3AA01-0AA0	
Input current	
from backplane bus 5 V DC, max.	620 mA
Power losses	
Power loss, max.	3 100 mW
Hardware configuration	
Cable length between first and last interface module, max.	102.25 m
Dimensions	
Width	25 mm
Height	290 mm
Depth	217 mm
Weight	
Weight, approx.	620 g

Ordering data

Ordering data	Order No.
IM 461-3 interface module	6ES7 461-3AA01-0AA0
Receiving interface module for distributed connection up to 102 m; with C bus transmission	
468-1 connecting cable	
between IM 460-3 and IM 461-3	
0.75 m	6ES7 468-1AH50-0AA0
1.5 m	6ES7 468-1BB50-0AA0
5 m	6ES7 468-1BF00-0AA0
10 m	6ES7 468-1CB00-0AA0
25 m	6ES7 468-1CC50-0AA0
50 m	6ES7 468-1CF00-0AA0
100 m	6ES7 468-1DB00-0AA0
Terminating connector	6ES7 461-3AA00-7AA0
for IM 461-3	

Overview



- Send interface for distributed expansion with SIMATIC S5 expansion racks up to 600 m
- Can be plugged into the central controller
- Up to 8 SIMATIC S5 expansion racks can be connected (up to 4 per interface)
- Can be used exclusively with IM 314

Technical specifications

6ES7 463-2AA00-0AA0	
Input current from backplane bus 5 V DC, max.	1 320 mA
Power losses Power loss, max.	6 600 mW
Hardware configuration Cable length between first and last interface module, max.	600 m
Dimensions	
Width	25 mm
Height	290 mm
Depth	217 mm
Weight Weight, approx.	360 g

Ordering data

IM 463-2 interface module
Receiving IM for distributed coupling of SIMATIC S5-EUs up to max. 600 m

Order No.

6ES7 463-2AA00-0AA0

SIMATIC S7-400

SIPLUS interface modules

SIPLUS IM 460-0

Overview



- Send interface module for centralized expansion up to 5 m
- Transfer from P and K Bus
- Plug into central controller
- You may connect up to 8 expansion units (max. 4 per port)
- Usable exclusively with IM 461-0

Note:

SIPLUS extreme products are based on Siemens Industry standard products. The contents listed here were taken from the respective standard products. SIPLUS extreme specific information was added.

SIPLUS IM 460-0	
Order number	6AG1 460-0AA01-2AB0
Order No. based on	6ES7 460-0AA01-0AB0
Ambient temperature range	-25 ... +60 °C
Conformal coating	Coating of the printed circuit boards and the electronic components
Technical data	The technical data of the standard product applies except for the ambient conditions.
Ambient conditions	
Relative humidity	100%, condensation/frost permissible. No commissioning if condensation present.
Biologically active substances, compliance with EN 60721-3-3	Class 3B2 mold and fungal spores (excluding fauna). The supplied plug covers must remain in place over the unused interfaces during operation!
Chemically active substances, compliance with EN 60721-3-3	Class 3C4 incl. salt spray in accordance with EN60068-2-52 (degree of severity 3). The supplied plug covers must remain in place over the unused interfaces during operation!
Mechanically active substances, compliance with EN 60721-3-3	Class 3S4 incl. sand, dust. The supplied plug covers must remain in place over the unused interfaces during operation!
Air pressure (depending on the highest positive temperature range specified)	1080 ... 795 hPa (-1000 ... +2000 m) see ambient temperature range 795 ... 658 hPa (+2000 ... +3500 m) derating 10 K 658 ... 540 hPa (+3500 ... +5000 m) derating 20 K

For technical documentation on SIPLUS, see:
www.siemens.com/siplus-extreme

Ordering data	Order No.
SIPLUS IM 460-0 interface module (extended temperature range and medial exposure) Send IM for central coupling up to 5 m; with C bus transfer	6AG1 460-0AA01-2AB0
Accessories	See SIMATIC IM 460-0, page 6/135

SIMATIC S7-400

SIPLUS interface modules

SIPLUS IM 461-0

Overview



- Receive interface connection for central extension up to 5 m
- Transfer from P and K Bus
- Pluggable in extension device
- Usable exclusively with IM 460-0

Note:

SIPLUS extreme products are based on Siemens Industry standard products. The contents listed here were taken from the respective standard products. SIPLUS extreme specific information was added.

SIPLUS IM 461

Order No.	6AG1 461-0AA01-2AA0
Order No. based on	6AG1 461-0AA01-2AA0
Ambient temperature range	-25 ... +60 °C
Conformal coating	Coating of the printed circuit boards and the electronic components
Technical data	The technical data of the standard product applies except for the ambient conditions.
Ambient conditions	
Relative humidity	100%, condensation/frost permissible. No commissioning if condensation present.
Biologically active substances, compliance with EN 60721-3-3	Class 3B2 mold and fungal spores (excluding fauna). The supplied plug covers must remain in place over the unused interfaces during operation!
Chemically active substances, compliance with EN 60721-3-3	Class 3C4 incl. salt spray in accordance with EN60068-2-52 (degree of severity 3). The supplied plug covers must remain in place over the unused interfaces during operation!
Mechanically active substances, compliance with EN 60721-3-3	Class 3S4 incl. sand, dust. The supplied plug covers must remain in place over the unused interfaces during operation!
Air pressure (depending on the highest positive temperature range specified)	1 080 ... 795 hPa (-1 000 ... +2 000 m) see ambient temperature range 795 ... 658 hPa (+2 000 ... +3 500 m) derating 10 K 658 ... 540 hPa (+3 500 ... +5 000 m) derating 20 K

For technical documentation on SIPLUS, see:
www.siemens.com/siplus-extreme

Ordering data	Order No.
SIPLUS IM 461-0 interface module (extended temperature range and medial exposure)	6AG1 461-0AA01-2AA0
Receiving IM for central coupling up to 5 m; with C bus transfer	
Accessories	See SIMATIC IM 461-0, page 6/136

SIMATIC S7-400

Power supplies

PS 405/407 power supply

Overview



- Power supplies for SIMATIC S7-400
- For conversion of AC or DC line voltages to the 5 V DC and 24 V DC operating voltages required
- 4 A, 10 A and 20 A output currents
- In addition:
 - SIPLUS power supply 6AG1 405-0KA02-2AA0 for temperature range of -25 to +60 °C and use under medium load (e.g. chlorine/sulfur atmosphere). Technical specifications similar to 6ES7 405-0KA02-0AA0
 - SIPLUS power supply 6AG1 407-0KA02-4AA0 for use under medium load (e.g. chlorine/sulfur atmosphere). Technical specifications similar to 6ES7 407-0KA02-0AA0
 - SIPLUS power supply 6AG1 407-0KR02-4AA0 for use under medium load (e.g. chlorine/sulfur atmosphere). Technical specifications similar to 6ES7 407-0KR02-0AA0

Technical specifications

	6ES7 405-0DA02-0AA0 PS405, 24 VDC, 5 VDC/4 A	6ES7 405-0KA02-0AA0 PS405, 24/48/60 VDC, 5 VDC/10 A	6ES7 405-0KR02-0AA0 PS405,24/48/60 VDC, 5 VDC/10 A,RED	6ES7 405-0RA02-0AA0 PS405, 24/48/60 VDC, 5 VDC/20 A
Supply voltage				
Rated value, 24 V DC	Yes	Yes	Yes	Yes
Rated value, 48 V DC	Yes	Yes	Yes	Yes
Rated value, 60 V DC	Yes	Yes	Yes	Yes
permissible range, lower limit (DC)	19.2 V; Dynamic 18.5 V	19.2 V; Dynamic 18.5 V	19.2 V; Dynamic 18.5 V	19.2 V; Dynamic 18.5 V
permissible range, upper limit (DC)	72 V; dynamic 75.5 V	72 V; dynamic 75.5 V	72 V; dynamic 75.5 V	72 V; dynamic 75.5 V
Mains buffering				
• Mains/voltage failure stored energy time	20 ms	20 ms	20 ms	20 ms
• Mains buffering according to NAMUR recommendation	Yes	Yes	Yes	Yes
Input current				
Rated value at 24 V DC	2 A	4 A	4 A	7 A
Rated value at 48 V DC	1 000 mA	2 A	2 A	3.2 A
Rated value at 60 V DC	800 mA	1.6 A	1.6 A	2.5 A
Inrush current, max.	18 A; Full width at half maximum 20 ms	18 A; Full width at half maximum 20 ms	18 A; Full width at half maximum 20 ms	56 A; Full width at half maximum 1.5 ms
Output voltage				
Rated value, 5 V DC	Yes	Yes	Yes	Yes
Rated value, 24 V DC	Yes	Yes	Yes	Yes
Output current				
for backplane bus (5 V DC), max.	4 A; no base load required	10 A; no base load required	10 A; no base load required	20 A; no base load required
for backplane bus (24 V DC), max.	0.5 A; idling-proof	1 A; idling-proof	1 A; idling-proof	1 A; idling-proof
Short-circuit protection	Yes	Yes	Yes	Yes
Power				
Power consumption, typ.	48 W	95 W	95 W	168 W
Power losses				
Power loss, typ.	16 W	20 W	20 W	44 W

Technical specifications (continued)

	6ES7 405-0DA02-0AA0 PS405, 24 VDC, 5 VDC/4 A	6ES7 405-0KA02-0AA0 PS405, 24/48/60 VDC, 5 VDC/10 A	6ES7 405-0KR02-0AA0 PS405,24/48/60 VDC, 5 VDC/10 A,RED	6ES7 405-0RA02-0AA0 PS405, 24/48/60 VDC, 5 VDC/20 A
Backup battery				
• Backup battery - Backup battery (optional)	Yes; 1 x lithium AA; 3.6 V/2.3 Ah	Yes; 2 x lithium AA; 3.6 V/2.3 Ah	Yes; 2 x lithium AA; 3.6 V/2.3 Ah	Yes; 2 x lithium AA; 3.6 V/2.3 Ah
Galvanic isolation				
primary/secondary	Yes	Yes	Yes	Yes
Degree and class of protection				
Protection class	1; with protective conductor	1; with protective conductor	1; with protective conductor	1; with protective conductor
Standards, approvals, certificates				
FM approval	Yes; Ta: 0 °C to 60 °C T4	Yes; Ta: 0 °C to 60 °C T4	Yes; Ta: 0 °C to 60 °C T4	Yes; Ta: 0 °C to 60 °C T4
Connection method				
Connecting cables/cross sections	3 x 1.5 mm ² , solid or stranded wire with end sleeve, external diameter 3 to 9 mm	3 x 1.5 mm ² , solid or stranded wire with end sleeve, external diameter 3 to 9 mm	3 x 1.5 mm ² , solid or stranded wire with end sleeve, external diameter 3 to 9 mm	3 x 1.5 mm ² , solid or stranded wire with end sleeve, external diameter 3 to 9 mm
Dimensions				
Width	25 mm	50 mm	50 mm	50 mm
Height	290 mm	290 mm	290 mm	290 mm
Depth	217 mm	217 mm	217 mm	217 mm
Required slots	1	2	2	2
Weight				
Weight, approx.	760 g	1 200 g	1 200 g	1 300 g
	6ES7 407-0DA02-0AA0	6ES7 407-0KA02-0AA0	6ES7 407-0KR02-0AA0	6ES7 407-0RA02-0AA0
Supply voltage				
Rated value, 110 V DC	Yes; Rated value 120 V DC	Yes; Rated value 120 V DC	Yes; Rated value 120 V DC	Yes; Rated value 120 V DC
Rated value, 230 V DC	Yes	Yes	Yes	Yes
permissible range, lower limit (DC)	88 V	88 V	88 V	88 V
permissible range, upper limit (DC)	300 V	300 V	300 V	300 V
Rated value, 120 V AC	Yes	Yes	Yes	Yes
Rated value, 230 V AC	Yes	Yes	Yes	Yes
Line frequency				
• Rated value 50 Hz	Yes	Yes	Yes	Yes
• Rated value 60 Hz	Yes	Yes	Yes	Yes
• Frequency of the supply voltage	47 Hz	47 Hz	47 Hz	47 Hz
• Frequency of the supply voltage	63 Hz	63 Hz	63 Hz	63 Hz
Mains buffering				
• Mains/voltage failure stored energy time	20 ms	20 ms	20 ms	20 ms
• Mains buffering according to NAMUR recommendation	Yes	Yes	Yes	Yes
Input current				
Rated value at 110 V DC	350 mA; at 120 V DC	1 A; at 120 V DC	1 A; at 120 V DC	1.4 A; at 120 V DC
Rated value at 230 V DC	190 mA	0.5 A	0.5 A	0.7 A
Rated value at 120 V AC	0.42 A	0.9 A	0.9 A	1.4 A
Rated value at 230 V AC	0.22 A	0.5 A	0.5 A	0.7 A
Inrush current, max.	8.25 A; Full width at half maximum 5 ms	63 A; Full width at half maximum 1 ms	63 A; Full width at half maximum 1 ms	88 A; Full width at half maximum 1.1 ms
Output voltage				
Rated value, 5 V DC	Yes	Yes	Yes	Yes
Rated value, 24 V DC	Yes	Yes	Yes	Yes

SIMATIC S7-400

Power supplies

PS 405/407 power supply

Technical specifications (continued)

	6ES7 407-0DA02-0AA0	6ES7 407-0KA02-0AA0	6ES7 407-0KR02-0AA0	6ES7 407-0RA02-0AA0
Output current				
for backplane bus (5 V DC), max.	4 A; no base load required	10 A; no base load required	10 A; no base load required	20 A; no base load required
for backplane bus (24 V DC), max.	0.5 A; idling-proof	1 A; idling-proof	1 A; idling-proof	1 A; idling-proof
Short-circuit protection	Yes	Yes	Yes	Yes
Power				
Power consumption, typ.	52 W	95 W	95 W	158 W
Power losses				
Power loss, typ.	20 W	20 W	20 W	35 W
Backup battery				
• Backup battery				
- Backup battery (optional)	Yes; 1 x lithium AA; 3.6 V/2.3 Ah	Yes; 2 x lithium AA; 3.6 V/2.3 Ah	Yes; 2 x lithium AA; 3.6 V/2.3 Ah	Yes; 2 x lithium AA; 3.6 V/2.3 Ah
Galvanic isolation				
primary/secondary	Yes	Yes	Yes	Yes
EMC				
Compliance with line harmonic distortion limits				
• Observance of line harmonic distortion acc. to IEC 61000-3-2, IEC 61000-3-3	Yes	Yes	Yes	Yes
Degree and class of protection				
Protection class	1; with protective conductor	1; with protective conductor	1; with protective conductor	1; with protective conductor
Standards, approvals, certificates				
FM approval	Yes; Ta: 0 °C to 60 °C T4	Yes; Ta: 0 °C to 60 °C T4	Yes; Ta: 0 °C to 60 °C T4	Yes; Ta: 0 °C to 60 °C T4
Connection method				
Connecting cables/cross sections	3 x 1.5 mm ² , solid or stranded wire with end sleeve, external diameter 3 to 9 mm	3 x 1.5 mm ² , solid or stranded wire with end sleeve, external diameter 3 to 9 mm	3 x 1.5 mm ² , solid or stranded wire with end sleeve, external diameter 3 to 9 mm	3 x 1.5 mm ² , solid or stranded wire with end sleeve, external diameter 3 to 9 mm
Dimensions				
Width	25 mm	50 mm	50 mm	50 mm
Height	290 mm	290 mm	290 mm	290 mm
Depth	217 mm	217 mm	217 mm	217 mm
Required slots	1	2	2	2
Weight				
Weight, approx.	760 g	1 200 g	1 200 g	1 300 g

SIMATIC S7-400

Power supplies

PS 405/407 power supply

Ordering data	Order No.	Ordering data	Order No.
PS 405 power supply modules		PS 407 power supply modules	
24 V DC; 5 V DC, 24 V DC		120/230 V AC; 5 V DC, 24 V DC	
4 A	6ES7 405-0DA02-0AA0	4 A	6ES7 407-0DA02-0AA0
10 A, wide range	6ES7 405-0KA02-0AA0	10 A	6ES7 407-0KA02-0AA0
10 A, redundant, wide range	6ES7 405-0KR02-0AA0	10 A, redundant	6ES7 407-0KR02-0AA0
20 A, wide range	6ES7 405-0RA02-0AA0	20 A	6ES7 407-0RA02-0AA0
Power plug for PS 405	6ES7 490-0AA00-0AA0	Power plug for PS 407	6ES7 490-0AB00-0AA0
Spare part		Spare part	
Backup battery	6ES7 971-0BA00	Backup battery	6ES7 971-0BA00
Type AA; 3.6 V/2.3 Ah		Type AA; 3.6 V/2.3 Ah	
		SITOP power supplies	See Catalog KT 01
		For the 24 V supply of motors or sensors	
		Add-on modules and DC-UPS	See Catalog KT 01
		To increase system availability	

SIMATIC S7-400

SIPLUS power supplies

SIPLUS power supplies

Overview



- Power supplies for SIPLUS S7-400
- For conversion of AC or DC line voltages to the 5 V DC and 24 V DC operating voltages required
- 4 A, 10 A and 20 A output currents

Note:

SIPLUS extreme products are based on Siemens Industry standard products. The contents listed here were taken from the respective standard products. SIPLUS extreme specific information was added.

SIPLUS S7-400 PS			
Order No.	6AG1 405-0KA02-7AA0	6AG1 407-0KA02-4AA0	6AG1 407-0KR02-4AA0
Order number based on	6ES7 405-0KA02-0AA0	6ES7 407-0KA02-0AA0	6ES7 407-0KR02-0AA0
Ambient temperature range	-25 ... +70 °C	-0 ... +60 °C	-0 ... +60 °C
Conformal coating	Coating of the printed circuit boards and the electronic components		
Technical data	The technical data of the standard product applies, except for the ambient conditions		
Ambient conditions			
Relative humidity	100%, condensation/frost permissible. No commissioning if condensation present.		
Biologically active substances, compliance with EN 60721-3-3	Class 3B2 mold and fungal spores (excluding fauna). The supplied plug covers must remain in place over the unused interfaces during operation!		
Chemically active substances, compliance with EN 60721-3-3	Class 3C4 incl. salt spray in accordance with EN60068-2-52 (degree of severity 3). The supplied plug covers must remain in place over the unused interfaces during operation!		
Mechanically active substances, compliance with EN 60721-3-3	Class 3S4 incl. sand, dust. The supplied plug covers must remain in place over the unused interfaces during operation!		
Air pressure (depending on the highest positive temperature range specified)	1 080 ... 795 hPa (-1 000 ... +2 000 m) see ambient temperature range 795 ... 658 hPa (+2 000 ... +3 500 m) derating 10 K 658 ... 540 hPa (+3 500 ... +5 000 m) derating 20 K		

For technical documentation on SIPLUS, see:
www.siemens.com/siplus-extreme

Ordering data	Order No.	Order No.
SIPLUS PS 405 power supply modules (extended temperature range and medial exposure) 24 V DC; 5 V DC, 24 V DC 10 A, wide range	6AG1 405-0KA02-7AA0	Accessories See SIMATIC PS 405/407 power supply, page 6/147
SIPLUS PS 407 power supply modules (medial exposure) 120/230 V AC; 5 V DC, 24 V DC 10 A 10 A, redundant	6AG1 407-0KA02-4AA0 6AG1 407-0KR02-4AA0	

Overview

Labeling sheets

- Film sheets for application-specific labeling of SIMATIC S7-400 I/O modules with commercial laser printers
- Single-color films, tear-resistant, dirt-resistant
- Easy handling:
 - Pre-perforated labeling sheets in DIN A4 format to allow easy separation of the labeling strips
 - The separated strips can be inserted directly into the I/O modules
- Different colors for distinction between module types or preferred areas of application:
The labeling sheets are available in the colors teal, light beige, red and yellow. Yellow is reserved for failsafe systems.

Label cover

- Film to cover and hold user-made labeling strips on normal paper
- Accessories, 10 pieces

Ordering data

Order No.

Labeling sheets

DIN A4, for printing using laser printer; 10 pieces

Petrol

6ES7 492-2AX00-0AA0

Light beige

6ES7 492-2BX00-0AA0

Yellow

6ES7 492-2CX00-0AA0

Red

6ES7 492-2DX00-0AA0

Cover film for labeling strips

6ES7 492-2XX00-0AA0

10 pieces (spare part)

SIMATIC S7-400

Accessories

Spare parts

Overview

Cover film for labeling strips

- Petrol-colored film for covering and fixing labeling strips created by the user
- On normal paper
- Spare part

Measuring range module for analog input modules

- Pluggable module for selecting the input ranges in the case of analog modules
- 1 module for 2 inputs
- Spare part

Slot cover

- Cover plates for unused slots in module racks
- Spare part, 10 units

Power supply connectors

- Plug for connecting the PS 405 and PS 407 power supply modules to the network
- Spare part

Replacement fan

- Fan unit for installation into the fan subassembly
- Spare part

Ordering data

Order No.

Cover foil for labeling strip 10 units (spare part)	6ES7 492-2XX00-0AA0
Range card for analog input modules 1 card for 2 inputs; 2 units (spare part)	6ES7 974-0AA00-0AA0
Slot covers for racks; 10 units (spare part)	6ES7 490-1AA00-0AA0
Power plug for PS 405 Spare part	6ES7 490-0AA00-0AA0
Power plug for PS 407 Spare part	6ES7 490-0AB00-0AA0
Replacement fan Spare part	6ES7 408-1TA00-6AA0

Overview



The ET 200M system with various interface modules is available for the decentralized use of S7-300 I/O modules. Depending on the application purpose, the best suited IM in terms of costs and functions can be selected:

IM 153-1 Standard

The IM 153-1 is one reasonably priced variant that is best suited for most applications in the manufacturing environment. It permits the use of up to 8 S7-300 I/O modules.

IM 153-2 High Feature

For higher requirements in manufacturing technology, such as the use of F-technology or the highest performance in conjunction with clock synchronization, the IM 153-2 High Feature is available. This IM is also designed for use with the PCS 7 in the field of manufacturing applications. This IM can be redundantly used and supports typical functions as they are required in the control field. These include, for example, clock synchronization or time stamping with an accuracy of up to 1ms.

Technical specifications

	6ES7 153-1AA03-0XB0	6ES7 153-2BA02-0XB0	6ES7 153-2BA82-0XB0
General information			
Vendor identification (VendorID)	801Dh	801Eh	801Eh
Supply voltage			
24 V DC	Yes	Yes	Yes
permissible range, lower limit (DC)	20.4 V	20.4 V	20.4 V
permissible range, upper limit (DC)	28.8 V	28.8 V	28.8 V
permissible range (ripple included), lower limit (DC)	20.4 V	20.4 V	20.4 V
permissible range (ripple included), upper limit (DC)	28.8 V	28.8 V	28.8 V
External protection for supply cables (recommendation)	not necessary	2.5 A	2.5 A
Mains buffering			
• Mains/voltage failure stored energy time	5 ms	5 ms	5 ms
Input current			
Current consumption, max.	350 mA; at 24 V DC	650 mA	650 mA
Rated value at 24 V DC	625 mA		
Inrush current, typ.	2.5 A	3 A	3 A
I^2t	0.1 A ² ·s	0.1 A ² ·s	0.1 A ² ·s
Output voltage			
Rated value, 5 V DC	Yes	Yes	Yes
Output current			
for backplane bus (5 V DC), max.	1 A	1.5 A	1.5 A
Power losses			
Power loss, typ.	3 W	5.5 W	5.5 W

SIMATIC S7-400

Modules for SIMATIC S7-400F/FH

IM 153-1/153-2

Technical specifications (continued)

	6ES7 153-1AA03-0XB0	6ES7 153-2BA02-0XB0	6ES7 153-2BA82-0XB0
Address area			
Addressing volume			
• Outputs	128 byte	244 byte	244 byte
• Inputs	128 byte	244 byte	244 byte
Hardware configuration			
Number of modules per DP slave interface, max.	8	12	12
Time stamping			
Accuracy		1 ms; 1ms at up to 8 modules; 10ms at up to 12 modules	1 ms; 1ms at up to 8 modules; 10ms at up to 12 modules
Number of message buffers		15	15
Messages per message buffer		20	20
Number of stampable digital inputs, max.		128; Max. 128 signals/station; max. 32 signals/slot	128; Max. 128 signals/station; max. 32 signals/slot
Time format		RFC 1119	RFC 1119
Time resolution		0.466 ns	0.466 ns
Time interval for transmitting the message buffer if a message is present		1 000 ms	1 000 ms
Time stamp on signal change		rising / falling edge as signal entering or exiting	rising / falling edge as signal entering or exiting
Interfaces			
Interface physics, RS 485	Yes	Yes	Yes
Interface physics, FOC	No	No	No
PROFIBUS DP			
• Node addresses	1 to 125 permitted	1 to 125 permitted	1 to 125 permitted
• Automatic detection of transmission speed	Yes	Yes	Yes
• PROFIBUS DP, output current, max.	90 mA	70 mA	70 mA
• Transmission procedure	RS 485	RS 485	RS 485
• Transmission rate, max.	12 Mbit/s	12 Mbit/s	12 Mbit/s
• SYNC capability	Yes	Yes	Yes
• FREECE capability	Yes	Yes	Yes
• Direct data exchange (slave-to-slave communication)	Yes; Sender	Yes; Sender	Yes; Sender
• PROFIBUS DP	9-pin sub D socket	9-pin sub D	9-pin sub D
1st interface			
DP slave			
• GSD file	(for DPV1) SIEM801D.GSD; SI01801D.GSG	SI04801.GSG	SI0480E.GSG
• Automatic baud rate search	Yes	Yes	Yes
Communication functions			
Bus protocol/transmission protocol	PROFIBUS DP to EN 50170	PROFIBUS DP to EN 50170	PROFIBUS DP to EN 50170
Isolation			
Isolation checked with	Isolation voltage 500 V	Isolation voltage 500 V	Isolation voltage 500 V
Degree and class of protection			
IP20	Yes	Yes	Yes
Ambient conditions			
Operating temperature			
• Min.	0 °C	0 °C	-25 °C
• max.	60 °C	60 °C	60 °C
Air pressure			
• Operating altitude above sea level, max.	3 000 m	3 000 m	3 000 m
Dimensions			
Width	40 mm	40 mm	40 mm
Height	125 mm	125 mm	125 mm
Depth	117 mm	117 mm	117 mm
Weight			
Weight, approx.	360 g	360 g	360 g

6

Technical specifications (continued)

6ES7 195-7HD10-0XA0		6ES7 195-7HA00-0XA0		6ES7 195-7HB00-0XA0		6ES7 195-7HC00-0XA0	
Accessories							
belongs to product	ET 200M						
Dimensions							
Width	97 mm						
Height	92 mm						
Depth	30 mm						
Weight							
Weight, approx.	133 g						
Dimensions							
Width	97 mm	97 mm	97 mm	97 mm	97 mm	97 mm	97 mm
Height	92 mm	92 mm	92 mm	92 mm	92 mm	92 mm	92 mm
Depth	30 mm	30 mm	30 mm	30 mm	30 mm	30 mm	30 mm
Weight							
Weight, approx.	111 g	140 g	140 g	140 g	127 g	127 g	127 g

Ordering data

Order No.	Order No.	Order No.
IM 153-1 interface module Slave interface for connecting an ET 200M to PROFIBUS DP <ul style="list-style-type: none"> Standard temperature range 	6ES7 153-1AA03-0XB0	Accessories PROFIBUS bus connector 90° outgoing cable, terminating resistor with disconnecting function, up to 12 Mbit/s, FastConnect Without PG interface <ul style="list-style-type: none"> 1 unit 100 units With PG interface <ul style="list-style-type: none"> 1 unit 100 units
IM 153-2 interface module Slave interface for connecting an ET 200M to PROFIBUS DP; also for use in redundant systems <ul style="list-style-type: none"> High Feature High Feature with extended temperature range 	6ES7 153-2BA02-0XB0 6ES7 153-2BA82-0XB0	SIMATIC DP DIN rail for ET 200M Accommodates up to 5 bus modules; for hot-swapping function <ul style="list-style-type: none"> Length: 483 mm (19") Length: 530 mm Length: 620 mm Length: 2000 mm
Active IM 153/IM 153 bus module For two IM 153-2 High Feature modules for designing redundant systems	6ES7 195-7HD10-0XA0	SIMATIC S7-300 mounting rail <ul style="list-style-type: none"> Length: 160 mm Length: 480 mm (19") Length: 530 mm Length: 830 mm Length: 2000 mm
Bus module for ET 200M <ul style="list-style-type: none"> To accommodate a power supply and an IM 153 module for the hot-swapping function during RUN, incl. bus module cover To accommodate two 40-mm wide I/O modules for the hot-swapping function To accommodate one 80-mm wide I/O module for the hot-swapping function 	6ES7 195-7HA00-0XA0 6ES7 195-7HB00-0XA0 6ES7 195-7HC00-0XA0	S7 Manual Collection Electronic manuals on DVD, multi-language: S7-200, TD 200, S7-300, M7-300, C7, S7-400, M7-400, STEP 7, Engineering Tools, Runtime Software, SIMATIC DP (Distributed I/O), SIMATIC HMI (Human Machine Interface), SIMATIC NET (Industrial Communication)
ET 200M redundancy bundle Comprising two IM 153-2 High Feature modules and one IM 153/IM 153 bus module	6ES7153-2AR03-0XA0	S7 Manual Collection, update service for 1 year Scope of delivery: Current DVD "S7 Manual Collection" and the three subsequent updates

SIMATIC S7-400

Modules for SIMATIC S7-400F/FH

SIPLUS IM 153-1/153-2

Overview



Note:

SIPLUS extreme products are based on Siemens Industry standard products. The contents listed here were taken from the respective standard products. SIPLUS extreme specific information was added.

6

	SIPLUS IM 153-1	SIPLUS IM 153-2	SIPLUS IM 153-2
Order No.	6AG1 153-1AA03-2XB0	6AG1 153-2BA02-2XY0	6AG1 153-2BA02-7XB0
Order number based on	6ES7 153-1AA03-0XB0	6ES7 153-2BA02-0XB0	6ES7 153-2BA02-0XB0
Ambient temperature range	-40 ... +70 °C Start-up temperature -25 °C	-25 ... +60 °C	-40 ... +70 °C Start-up temperature -25 °C
Compliant with the standards for electronic equipment used on rolling stock (EN 50155, temperature T1, category 1).	No	Yes	No
Conformal coating	Coating of the printed circuit boards and the electronic components		
Technical data	The technical data of the standard product applies except for the ambient conditions.		

SIPLUS bus module	for accommodating a PS and an IM 153	for accommodating two 40 mm wide I/O modules
Order No.	6AG1 195-7HA00-2XA0	6AG1 195-7HB00-7XA0
Order number based on	6ES7 195-7HA00-0XA0	6ES7 195-7HB00-0XA0
Ambient temperature range	-40 ... +70 °C	-40 ... +70 °C
Compliant with the standards for electronic equipment used on rolling stock (EN 50155, temperature T1, category 1).	No	Yes
Conformal coating	Coating of the printed circuit boards and the electronic components	
Technical data	The technical data of the standard product applies except for the ambient conditions.	

SIPLUS bus module	for accommodating an 80 mm module	for accommodating two IM 153-2
Order No.	6AG1 195-7HC00-2XA0	6AG1 195-7HD10-2XA0
Order number based on	6ES7 195-7HC00-0XA0	6ES7 195-7HD10-0XA0
Ambient temperature range	-40 ... +70 °C	-40 ... +70 °C
Compliant with the standards for electronic equipment used on rolling stock (EN 50155, temperature T1, category 1).	No	Yes
Conformal coating	Coating of the printed circuit boards and the electronic components	
Technical data	The technical data of the standard product applies except for the ambient conditions.	

SIMATIC S7-400

Modules for SIMATIC S7-400F/FH

SIPLUS IM 153-1/153-2

Overview (continued)		Ordering data	Order No.
Ambient conditions		IM 153-1 interface module	
Relative humidity	100%, condensation/frost permissible. No commissioning if condensation present.	(extended temperature range and medial exposure) Slave interface for connecting an ET 200M to PROFIBUS DP • Standard temperature range	6AG1 153-1AA03-2XB0
Biologically active substances, compliance with EN 60721-3-3	Class 3B2 mold and fungal spores (excluding fauna). The supplied plug covers must remain in place over the unused interfaces during operation!	IM 153-2 interface module	
Chemically active substances, compliance with EN 60721-3-3	Class 3C4 incl. salt spray in accordance with EN60068-2-52 (degree of severity 3). The supplied plug covers must remain in place over the unused interfaces during operation!	(extended temperature range and medial exposure) Slave interface for connecting an ET 200M to PROFIBUS DP; also for use in redundant systems • High Feature, -25 ... +60 °C • High Feature, -40 ... +70 °C	6AG1 153-2BA02-2XY0 6AG1 153-2BA02-7XB0
Mechanically active substances, compliance with EN 60721-3-3	Class 3S4 incl. sand, dust. The supplied plug covers must remain in place over the unused interfaces during operation!	Active IM 153/IM 153 bus module	6AG1 195-7HD10-2XA0
Air pressure (depending on the highest positive temperature range specified)	1 080 ... 795 hPa (-1 000 ... +2 000 m) see ambient temperature range 795 ... 658 hPa (+2 000 ... +3 500 m) derating 10 K 658 ... 540 hPa (+3 500 ... +5 000 m) derating 20 K	(extended temperature range and medial exposure) For two IM 153-2 High Feature modules for designing redundant systems	
		Bus module for ET 200M	
		(extended temperature range and medial exposure) • To accommodate a power supply and an IM 153 for the hot-swapping function during RUN, incl. bus module cover • To accommodate two 40 mm wide I/O modules for the hot-swapping function • To accommodate one 80 mm wide I/O module for the hot swapping function	6AG1 195-7HA00-2XA0 6AG1 195-7HB00-7XA0 6AG1 195-7HC00-2XA0
		Accessories	See SIMATIC ET 200M IM 153-1/153-2, page 6/153

For technical documentation on SIPLUS, see:

www.siemens.com/siplus-extreme

SIMATIC S7-400

Modules for SIMATIC S7-400F/FH

Isolation modules

Overview



- Supports mixed operation of fail-safe signal modules in safety mode and S7-300 standard modules in an ET 200M when Cat. 4 or SIL 3 has to be achieved.
- The isolation module is not required if the safety class or safety category to be achieved is less than SIL 3 or Cat. 4, respectively.

When Cat. 4/SIL 3 is required, the isolation module must be implemented in the following situations:

Application	Isolation module must be used
Central use after CPU 31xF-2 DP or CPU 31xF-2 PN/DP <ul style="list-style-type: none"> • Only fail-safe modules in the tier • Standard and fail-safe modules in the tier 	Yes, behind the CPU Yes, after the last standard module and before the first fail-safe module
Central use after CPU 31xF-2 DP or CPU 31xF-2 PN/DP in an expansion rack <ul style="list-style-type: none"> • Only fail-safe modules in the tier • Standard and fail-safe modules in the tier 	Yes, after the IM 36x Yes, after the last standard module and before the first fail-safe module
Distributed behind the IM 153-2 with copper connection <ul style="list-style-type: none"> • Only fail-safe modules in the station • Standard and fail-safe modules in the station 	Yes, after the IM 153-2 Yes, after the last standard module and before the first fail-safe module
Distributed behind the IM 153-2 with fiber-optic connection <ul style="list-style-type: none"> • Only fail-safe modules in the station • Standard and fail-safe modules in the station 	No Yes, after the last standard module and before the first fail-safe module

Technical specifications

	6ES7 195-7KF00-0XA0
Weight	
Weight, approx.	10 g

Ordering data

	Order No.
Isolation module	6ES7 195-7KF00-0XA0
for simultaneous operation of fail-safe and standard modules in an ET 200M	
Isolation bus module	6ES7 195-7HG00-0XA0
for accommodating the isolating module in an ET 200M	

SIMATIC S7-400

Modules for SIMATIC S7-400F/FH

SIPLUS isolation modules

Overview



- Permits combined operation of fail-safe signal modules in safety mode and standard S7-300 modules in the same ET 200M system.
- The isolation module is not required if the safety class SIL 3 or safety category < Cat. 4 is to be achieved.

Note:

SIPLUS extreme products are based on Siemens Industry standard products. The contents listed here were taken from the respective standard products. SIPLUS extreme specific information was added.

SIPLUS S7-300 isolation module	
Order No.	6AG1 195-7KF00-2XA0
Order No. based on	6ES7 195-7KF00-0XA0
Ambient temperature range	- 25 ... +60 °C
Conformal coating	Coating of the printed circuit boards and the electronic components
Technical data	The technical data of the standard product applies except for the ambient conditions.
Compliant with the standards for electronic equipment used on rolling stock (EN 50155, temperature T1, category 1)	Yes
Ambient conditions	
Relative humidity	100%, condensation/frost permissible. No commissioning if condensation present.

For technical documentation on SIPLUS, see:
www.siemens.com/siplus-extreme

Ordering data

Order No.

SIPLUS isolation module

(extended temperature range and medial exposure)

for simultaneous operation of fail-safe and standard modules in the same ET 200M

6AG1 195-7KF00-2XA0

Accessories

SIPLUS ET 200M isolation bus module F

6AG1 195-7HG00-2XA0

SIMATIC S7-400

Modules for SIMATIC S7-400F/FH

Fail-safe I/O modules

Overview



- Failsafe input/output modules for use with the SIMATIC S7-400F/FH
- With integrated safety functions
- Can only be plugged into the ET 200M
- Achievable safety classes in safety operation: SIL 2, SIL 3 to IEC 61508, AK 4, AK 6 to DIN V 19250, Category 3, 4 to EN 954-1
- Use in standard mode with high diagnostics requirements
- Also suitable for redundant operation

For more information, see chap. 5, page 5/88.

Embedded Controller



7/2 SIMATIC S7-modular Embedded Controller

7/2 EC31
7/10 Expansion modules

7/11 Communication

7/11 CP 5603
7/15 CP 1604

7/18 Embedded bundles/ Software packages

7/18 SIMATIC IPC227D bundles
7/20 SIMATIC IPC427C bundles
7/23 SIMATIC IPC277D bundles
7/25 SIMATIC HMI IPC477C bundles
7/31 Software packages for SIMATIC IPC and S7-mEC

Brochures

For brochures serving as selection guides for SIMATIC products refer to:

www.siemens.com/simatic/printmaterial

Embedded Controller

SIMATIC S7-modular Embedded Controller

EC31

Overview



For brochures serving as selection guides for SIMATIC products refer to:

www.siemens.com/simatic/printmaterial

- Get off to a fast start in automation solutions with embedded PC platforms.
 - Ready-to-use SIMATIC WinAC RTX or WinAC RTX F preinstalled on EC31
 - Prepared for use in a SIMATIC environment with PROFINET and Industrial Ethernet
 - Commissioning by specialist automation personnel as with the S7-300
 - Configuring and programming with SIMATIC STEP 7 over Industrial Ethernet
 - Optional visualization
- Modular expansion capability:
 - Central expansion with
 - S7-300 I/O (SM modules of S7-300)
 - Expansion modules for additional PC interfaces, e.g. DVI-I, USB, Gigabit Ethernet networks and memory card slots, as well as PCI-104
- Rugged operation
 - Hard-disk-free operation based on flash disk and Windows Embedded Standard
 - Fan-free operation
- Flexibility of a PC-based automation environment
 - Free memory space on flash disk can be used for other PC applications
 - Use of WinAC ODK with SIMATIC WinAC RTX and WinAC RTX F (read-only in safety-related program part)
 - Connection option for USB devices
 - Memory capacity expandable using multimedia card
- Data retentivity for WinAC RTX and RTX F without uninterruptible power supply (UPS)

Technical specifications

	6ES7 677-1DD10-0BA0 SIMATIC S7-mEC, EC31	6ES7 677-1DD10-0BB0 S7-mEC, EC31-RTX	6ES7 677-1FD10-0FB0 S7-mEC, EC31-RTX F	6ES7 677-1DD10-0BF0 S7-mEC, EC31-HMI/RTX 128PT	6ES7 677-1DD10-0BG0 S7-mEC, EC31-HMI/RTX 512PT	6ES7 677-1DD10-0BH0 S7-mEC, EC31-HMI/RTX 2048PT
General information						
Hardware product version	01	01	01	01	01	01
Firmware version	V2.0	V2.0	V2.0	V2.0	V2.0	V2.0
PC configuration						
Computer platform	SIMATIC S7 modular embedded controller	SIMATIC S7 modular embedded controller	SIMATIC S7 modular embedded controller	SIMATIC S7 modular embedded controller	SIMATIC S7 modular embedded controller	SIMATIC S7 modular embedded controller
Processor selection	Intel Core Duo 1.2 GHz	Intel Core Duo 1.2 GHz	Intel Core Duo 1.2 GHz	Intel Core Duo 1.2 GHz	Intel Core Duo 1.2 GHz	Intel Core Duo 1.2 GHz
Main memory	1 GB RAM	1 GB RAM	1 GB RAM	1 GB RAM	1 GB RAM	1 GB RAM
Operating systems	Windows Embedded Standard 2009	Windows Embedded Standard 2009	Windows Embedded Standard 2009	Windows Embedded Standard 2009	Windows Embedded Standard 2009	Windows Embedded Standard 2009
Installed software						
• Visualization				WinCC flexible RT 2008 SP2, incl. Sm@rtAccess, recipes, archives options	WinCC flexible RT 2008 SP2, incl. Sm@rtAccess, recipes, archives options	WinCC flexible RT 2008 SP2, incl. Sm@rtAccess, recipes, archives options
• Control		SIMATIC WinAC RTX 2010	SIMATIC WinAC RTX F 2010	SIMATIC WinAC RTX 2010	SIMATIC WinAC RTX 2010	SIMATIC WinAC RTX 2010
• Communication		Yes	Yes	Yes	Yes	Yes

Embedded Controller

SIMATIC S7-modular Embedded Controller

EC31

Technical specifications (continued)

	6ES7 677-1DD10-0BA0 SIMATIC S7-mEC, EC31	6ES7 677-1DD10-0BB0 S7-mEC, EC31-RTX	6ES7 677-1FD10-0FB0 S7-mEC, EC31-RTX F	6ES7 677-1DD10-0BF0 S7-mEC, EC31-HMI/RTX 128PT	6ES7 677-1DD10-0BG0 S7-mEC, EC31-HMI/RTX 512PT	6ES7 677-1DD10-0BH0 S7-mEC, EC31-HMI/RTX 2048PT
Power losses						
Power loss, typ.	34 W	34 W	34 W	34 W	34 W	34 W
Memory						
Memory type	256 KB non-volatile memory for retentive data	512 KB non-volatile memory for retentive data	512 KB non-volatile memory for retentive data	512 KB non-volatile memory for retentive data	512 KB non-volatile memory for retentive data	512 KB non-volatile memory for retentive data
Work memory						
• integrated	1 Gbyte	1 Gbyte	1 Gbyte	1 Gbyte	1 Gbyte	1 Gbyte
CPU processing times						
for bit operations, typ.		0.004 µs; typ.	0.004 µs; typ.	0.004 µs; typ.	0.004 µs; typ.	0.004 µs; typ.
for fixed point arithmetic, typ.		0.003 µs; typ.	0.003 µs; typ.	0.003 µs; typ.	0.003 µs; typ.	0.003 µs; typ.
for floating point arithmetic, typ.		0.004 µs; typ.	0.004 µs; typ.	0.004 µs; typ.	0.004 µs; typ.	0.004 µs; typ.
CPU-blocks						
DB						
• Number, max.		Max. code size and max. data size: 4 MB each	Max. code size and max. data size: 4 MB each	Max. code size and max. data size: 4 MB each	Max. code size and max. data size: 4 MB each	Max. code size and max. data size: 4 MB each
• Size, max.		64 kbyte	64 kbyte	64 kbyte	64 kbyte	64 kbyte
FB						
• Number, max.		Max. code size and max. data size: 4 MB each	Max. code size and max. data size: 4 MB each	Max. code size and max. data size: 4 MB each	Max. code size and max. data size: 4 MB each	Max. code size and max. data size: 4 MB each
• Size, max.		64 kbyte	64 kbyte	64 kbyte	64 kbyte	64 kbyte
FC						
• Number, max.		Max. code size and max. data size: 4 MB each	Max. code size and max. data size: 4 MB each	Max. code size and max. data size: 4 MB each	Max. code size and max. data size: 4 MB each	Max. code size and max. data size: 4 MB each
• Size, max.		64 kbyte	64 kbyte	64 kbyte	64 kbyte	64 kbyte
OB						
• Size, max.		64 kbyte	64 kbyte	64 kbyte	64 kbyte	64 kbyte
• Number of startup OBs		2; OB 100, 102	2; OB 100, 102	2; OB 100, 102	2; OB 100, 102	2; OB 100, 102
• Number of asynchronous error OBs		7; OB 80, 82-85, 86, 88	7; OB 80, 82-85, 86, 88	7; OB 80, 82-85, 86, 88	7; OB 80, 82-85, 86, 88	7; OB 80, 82-85, 86, 88
• Number of synchronous error OBs		2; OB 121, 122	2; OB 121, 122	2; OB 121, 122	2; OB 121, 122	2; OB 121, 122
Nesting depth						
• per priority class		24	24	24	24	24
• additional within an error OB		24	24	24	24	24
Counters, timers and their retentivity						
S7 counter						
• Number		2 048	2 048	2 048	2 048	2 048
• Retentivity						
- adjustable		Yes	Yes	Yes	Yes	Yes
- lower limit		0	0	0	0	0
- upper limit		2 047	2 047	2 047	2 047	2 047
- preset		8	8	8	8	8
• Counting range						
- adjustable		Yes	Yes	Yes	Yes	Yes
- lower limit		0	0	0	0	0
- upper limit		999	999	999	999	999
IEC counter						
• present		Yes	Yes	Yes	Yes	Yes
• Type		SFB	SFB	SFB	SFB	SFB

7

Embedded Controller

SIMATIC S7-modular Embedded Controller

EC31

Technical specifications (continued)

	6ES7 677-1DD10-0BA0 SIMATIC S7-mEC, EC31	6ES7 677-1DD10-0BB0 S7-mEC, EC31-RTX	6ES7 677-1FD10-0FB0 S7-mEC, EC31-RTX F	6ES7 677-1DD10-0BF0 S7-mEC, EC31-HMI/RTX 128PT	6ES7 677-1DD10-0BG0 S7-mEC, EC31-HMI/RTX 512PT	6ES7 677-1DD10-0BH0 S7-mEC, EC31-HMI/RTX 2048PT
S7 times						
• Number		2 048	2 048	2 048	2 048	2 048
• Retentivity						
- adjustable		Yes	Yes	Yes	Yes	Yes
- lower limit		0	0	0	0	0
- upper limit		2 047	2 047	2 047	2 047	2 047
• Time range						
- lower limit		10 ms	10 ms	10 ms	10 ms	10 ms
- upper limit		9 990 s	9 990 s	9 990 s	9 990 s	9 990 s
IEC timer						
• present		Yes	Yes	Yes	Yes	Yes
• Type		SFB	SFB	SFB	SFB	SFB
Data areas and their retentivity						
retentive data area, total		512 KB	512 KB	512 KB	512 KB	512 KB
Flag						
• Number, max.		16 kbyte	16 kbyte	16 kbyte	16 kbyte	16 kbyte
• Retentivity preset		MB 0 to MB 15	MB 0 to MB 15	MB 0 to MB 15	MB 0 to MB 15	MB 0 to MB 15
• Number of clock memories		8	8	8	8	8
Address area						
I/O address area						
• Inputs		16 kbyte	16 kbyte	16 kbyte	16 kbyte	16 kbyte
• Outputs		16 kbyte	16 kbyte	16 kbyte	16 kbyte	16 kbyte
• of which, distributed						
- Inputs		8 kbyte	8 kbyte	8 kbyte	8 kbyte	8 kbyte
- Outputs		8 kbyte	8 kbyte	8 kbyte	8 kbyte	8 kbyte
Process image						
• Inputs, adjustable		16 kbyte	16 kbyte	8 kbyte	8 kbyte	8 kbyte
• Outputs, adjustable		16 kbyte	16 kbyte	8 kbyte	8 kbyte	8 kbyte
• Inputs, default		512 byte	512 byte	512 byte	512 byte	512 byte
• Outputs, default		512 byte	512 byte	512 byte	512 byte	512 byte
Subprocess images						
• Number of subprocess images, max.		15	15	15	15	15
Digital channels						
• Inputs		128 000	128 000	128 000	128 000	128 000
• Outputs		128 000	128 000	128 000	128 000	128 000
Analog channels						
• Inputs		8 000	8 000	8 000	8 000	8 000
• Outputs		8 000	8 000	8 000	8 000	8 000
Time of day						
Clock						
• Hardware clock (real-time clock)		Yes	Yes; Resolution: 1 s	Yes	Yes	Yes
Clock synchronization						
• supported		Yes	Yes	Yes	Yes	Yes
• to PC-CP, slave		Yes	Yes	Yes	Yes	Yes
• on Ethernet via NTP		Yes	Yes	Yes	Yes	Yes

Embedded Controller

SIMATIC S7-modular Embedded Controller

EC31

Technical specifications (continued)

	6ES7 677-1DD10-0BA0 SIMATIC S7-mEC, EC31	6ES7 677-1DD10-0BB0 S7-mEC, EC31-RTX	6ES7 677-1FD10-0FB0 S7-mEC, EC31-RTX F	6ES7 677-1DD10-0BF0 S7-mEC, EC31-HMI/RTX 128PT	6ES7 677-1DD10-0BG0 S7-mEC, EC31-HMI/RTX 512PT	6ES7 677-1DD10-0BH0 S7-mEC, EC31-HMI/RTX 2048PT
Interfaces						
Number of USB interfaces	2	2		2	2	2
serial interface	0	0		0	0	0
Industrial Ethernet						
• Industrial Ethernet interface	X1: 2 ports 10/100 Mbit/s (ERTEC-based) X2: 1 port 10/100 Mbit/s	X1: 2 ports 10/100 Mbit/s (ERTEC-based) X2: 1 port 10/100 Mbit/s	X1: 2 ports 10/100 Mbit/s (ERTEC-based) X2: 1 port 10/100 Mbit/s	X1: 2 ports 10/100 Mbit/s (ERTEC-based) X2: 1 port 10/100 Mbit/s	X1: 2 ports 10/100 Mbit/s (ERTEC-based) X2: 1 port 10/100 Mbit/s	X1: 2 ports 10/100 Mbit/s (ERTEC-based) X2: 1 port 10/100 Mbit/s
1st interface						
Type of interface		PROFINET	PROFINET	PROFINET	PROFINET	PROFINET
Physics		2x RJ45	2x RJ45	2x RJ45	2x RJ45	2x RJ45
Automatic detection of transmission speed		Yes	Yes	Yes	Yes	Yes
Autonegotiation		Yes	Yes	Yes	Yes	Yes
Autocrossing		Yes	Yes	Yes	Yes	Yes
Number of connection resources		32	32	32	32	32
Functionality						
• MPI			No			
• DP master			No			
• DP slave			No			
• PROFINET IO Device		No	No	No	No	No
• PROFINET IO Controller		Yes	Yes	Yes	Yes	Yes
• PROFINET CBA		Yes	Yes	Yes	Yes	Yes
• Point-to-point connection			No			
PROFINET IO Controller						
• Number of connectable IO devices, max.		256	256	256	256	256
• Max. number of connectable IO devices for RT		256	256	256	256	256
- of which in line, max.		256	256	256	256	256
• Number of IO devices with IRT and the option "high flexibility"		256	256	256	256	256
- of which in line, max.		61	61	61	61	61
• Number of IO Devices with IRT and the option "high performance", max.		256	256	256	256	256
- of which in line, max.		64	64	64	64	64
• IRT, supported		Yes	Yes	Yes	Yes	Yes
• Prioritized startup supported		Yes	Yes	Yes	Yes	Yes
- Number of IO Devices, max.		32	32	32	32	32
• Activation/deactivation of IO Devices		Yes	Yes	Yes	Yes	Yes
- Maximum number of IO devices that can be activated/deactivated at the same time.		8	8	8	8	8
• IO Devices changing during operation (partner ports), supported		Yes	Yes	Yes	Yes	Yes
- Max. number of IO devices per tool		8	8	8	8	8

7

Embedded Controller

SIMATIC S7-modular Embedded Controller

EC31

Technical specifications (continued)

	6ES7 677-1DD10-0BA0 SIMATIC S7-mEC, EC31	6ES7 677-1DD10-0BB0 S7-mEC, EC31-RTX	6ES7 677-1FD10-0FB0 S7-mEC, EC31-RTX F	6ES7 677-1DD10-0BF0 S7-mEC, EC31-HMI/RTX 128PT	6ES7 677-1DD10-0BG0 S7-mEC, EC31-HMI/RTX 512PT	6ES7 677-1DD10-0BH0 S7-mEC, EC31-HMI/RTX 2048PT
<ul style="list-style-type: none"> Device replacement without swap medium Send cycles 		Yes	Yes	Yes	Yes	Yes
<ul style="list-style-type: none"> Updating times 		Adjustable: 250 µs, 500 µs and 1 ms	Adjustable: 250 µs, 500 µs and 1 ms	Adjustable: 250 µs, 500 µs and 1 ms	Adjustable: 250 µs, 500 µs and 1 ms	Adjustable: 250 µs, 500 µs and 1 ms
<ul style="list-style-type: none"> Services <ul style="list-style-type: none"> - PG/OP communication - S7 routing - S7 communication - Isochronous mode Address area <ul style="list-style-type: none"> - Inputs, max. - Outputs, max. - User data per address area, max. - User data consistency, max. 		250 µs - 128 ms (with signal cycle 250 µs); 500 µs - 256 ms (with signal cycle 500 µs); 1 ms - 512 ms (with signal cycle 1 ms)	250 µs - 128 ms (with signal cycle 250 µs); 500 µs - 256 ms (with signal cycle 500 µs); 1 ms - 512 ms (with signal cycle 1 ms)	250 µs - 128 ms (with signal cycle 250 µs); 500 µs - 256 ms (with signal cycle 500 µs); 1 ms - 512 ms (with signal cycle 1 ms)	250 µs - 128 ms (with signal cycle 250 µs); 500 µs - 256 ms (with signal cycle 500 µs); 1 ms - 512 ms (with signal cycle 1 ms)	250 µs - 128 ms (with signal cycle 250 µs); 500 µs - 256 ms (with signal cycle 500 µs); 1 ms - 512 ms (with signal cycle 1 ms)
<ul style="list-style-type: none"> Open IE communication <ul style="list-style-type: none"> • Open IE communication, supported • Number of connections, max. • Local port numbers used at the system end 		Yes	Yes	Yes	Yes	Yes
<ul style="list-style-type: none"> PROFINET functions <ul style="list-style-type: none"> • Detection of accessible nodes, supported • Assignment of the IP address, supported • Assignment of the device name, supported • Topology recognition, supported • Extended network diagnostics with Standard MIB II, supported 		32	32	32	32	32
		0, 20, 21, 23, 25, 80, 102, 135, 161, 8080, 34962, 34963, 34964, 65532, 65533, 65534, 65535	0, 20, 21, 23, 25, 80, 102, 135, 161, 8080, 34962, 34963, 34964, 65532, 65533, 65534, 65535	0, 20, 21, 23, 25, 80, 102, 135, 161, 8080, 34962, 34963, 34964, 65532, 65533, 65534, 65535	0, 20, 21, 23, 25, 80, 102, 135, 161, 8080, 34962, 34963, 34964, 65532, 65533, 65534, 65535	0, 20, 21, 23, 25, 80, 102, 135, 161, 8080, 34962, 34963, 34964, 65532, 65533, 65534, 65535
		Yes; DCP	Yes; DCP	Yes; DCP	Yes; DCP	Yes; DCP
		Yes; DCP	Yes; DCP	Yes; DCP	Yes; DCP	Yes; DCP
		Yes; DCP	Yes; DCP	Yes; DCP	Yes; DCP	Yes; DCP
		Yes; LLDP, LLDP MIB, SNMP	Yes; LLDP, LLDP MIB, SNMP	Yes; LLDP, LLDP MIB, SNMP	Yes; LLDP, LLDP MIB, SNMP	Yes; LLDP, LLDP MIB, SNMP
		Yes; Standard MIB II, SNMP	Yes; Standard MIB II, SNMP	Yes; Standard MIB II, SNMP	Yes; Standard MIB II, SNMP	Yes; Standard MIB II, SNMP
2nd interface						
Type of interface		Integrated Ethernet interface	Integrated Ethernet interface	Integrated Ethernet interface	Integrated Ethernet interface	Integrated Ethernet interface
Physics		Ethernet RJ45	Ethernet RJ45	Ethernet RJ45	Ethernet RJ45	Ethernet RJ45
Automatic detection of transmission speed		Yes	Yes	Yes	Yes	Yes
Autonegotiation		Yes	Yes	Yes	Yes	Yes
Autocrossing		No	No	No	No	No
Number of connection resources		32	32	32	32	32

Technical specifications (continued)

	6ES7 677-1DD10-0BA0 SIMATIC S7-mEC, EC31	6ES7 677-1DD10-0BB0 S7-mEC, EC31-RTX	6ES7 677-1FD10-0FB0 S7-mEC, EC31-RTX F	6ES7 677-1DD10-0BF0 S7-mEC, EC31-HMI/RTX 128PT	6ES7 677-1DD10-0BG0 S7-mEC, EC31-HMI/RTX 512PT	6ES7 677-1DD10-0BH0 S7-mEC, EC31-HMI/RTX 2048PT
Functionality		No	No	No	No	No
• PROFINET IO Controller		No	No	No	No	No
• PROFINET IO Device		No	No	No	No	No
• PROFINET CBA		No	No	No	No	No
PROFINET functions		Yes; DCP	Yes; DCP	Yes; DCP	Yes; DCP	Yes; DCP
• Detection of accessible nodes, supported		Yes; DCP	Yes; DCP	Yes; DCP	Yes; DCP	Yes; DCP
• Assignment of the IP address, supported		Yes; DCP	Yes; DCP	Yes; DCP	Yes; DCP	Yes; DCP
• Assignment of the device name, supported		Yes; DCP	Yes; DCP	Yes; DCP	Yes; DCP	Yes; DCP
• Topology recognition, supported		Yes; LLDP, LLDP MIB, SNMP	Yes; LLDP, LLDP MIB, SNMP	Yes; LLDP, LLDP MIB, SNMP	Yes; LLDP, LLDP MIB, SNMP	Yes; LLDP, LLDP MIB, SNMP
• Extended network diagnostics with Standard MIB II, supported		Yes; Standard MIB II, SNMP	Yes; Standard MIB II, SNMP	Yes; Standard MIB II, SNMP	Yes; Standard MIB II, SNMP	Yes; Standard MIB II, SNMP
Communication functions						
PG/OP communication		Yes	Yes	Yes	Yes	Yes
Global data communication		No	No	No	No	No
• supported		No	No	No	No	No
S7 basic communication		No	No	No	No	No
• supported		No	No	No	No	No
S7 communication		Yes	Yes	Yes	Yes	Yes
• supported		Yes	Yes	Yes	Yes	Yes
• as server		Yes	Yes	Yes	Yes	Yes
• as client		Yes	Yes	Yes	Yes	Yes
Open IE communication		Yes; Via integrated PROFINET interface (X1) and loadable FBs	Yes; Via integrated PROFINET interface (X1) and loadable FBs	Yes; Via integrated PROFINET interface (X1) and loadable FBs	Yes; Via integrated PROFINET interface (X1) and loadable FBs	Yes; Via integrated PROFINET interface (X1) and loadable FBs
• TCP/IP		Yes; Via integrated PROFINET interface (X1) and loadable FBs	Yes; Via integrated PROFINET interface (X1) and loadable FBs	Yes; Via integrated PROFINET interface (X1) and loadable FBs	Yes; Via integrated PROFINET interface (X1) and loadable FBs	Yes; Via integrated PROFINET interface (X1) and loadable FBs
- Number of connections, max.		32	32	32	32	32
- Data length, max.		32 kbyte	32 kbyte	32 kbyte	32 kbyte	32 kbyte
• ISO-on-TCP (RFC1006)		Yes; Via integrated PROFINET interface (X1) and loadable FBs	Yes; Via integrated PROFINET interface (X1) and loadable FBs	Yes; Via integrated PROFINET interface (X1) and loadable FBs	Yes; Via integrated PROFINET interface (X1) and loadable FBs	Yes; Via integrated PROFINET interface (X1) and loadable FBs
- Number of connections, max.		32	32	32	32	32
- Data length, max.		32 kbyte	32 kbyte	32 kbyte	32 kbyte	32 kbyte
• UDP		Yes; Via integrated PROFINET interface (X1) and loadable FBs	Yes; Via integrated PROFINET interface (X1) and loadable FBs	Yes; Via integrated PROFINET interface (X1) and loadable FBs	Yes; Via integrated PROFINET interface (X1) and loadable FBs	Yes; Via integrated PROFINET interface (X1) and loadable FBs
- Number of connections, max.		32	32	32	32	32
- Data length, max.		1 472 byte	1 472 byte	1 472 byte	1 472 byte	1 472 byte
S7 message functions						
Number of login stations for message functions, max.		62; The alarm functions cannot currently be used for central bus modules	62; The alarm functions cannot currently be used for central bus modules	62; The alarm functions cannot currently be used for central bus modules	62; The alarm functions cannot currently be used for central bus modules	62; The alarm functions cannot currently be used for central bus modules
Process diagnostic messages		Yes; Alarm_S	Yes; Alarm_S	Yes; Alarm_S	Yes; Alarm_S	Yes; Alarm_S

Embedded Controller

SIMATIC S7-modular Embedded Controller

EC31

Technical specifications (continued)

	6ES7 677-1DD10-0BA0 SIMATIC S7-mEC, EC31	6ES7 677-1DD10-0BB0 S7-mEC, EC31-RTX	6ES7 677-1FD10-0FB0 S7-mEC, EC31-RTX F	6ES7 677-1DD10-0BF0 S7-mEC, EC31-HMI/ RTX 128PT	6ES7 677-1DD10-0BG0 S7-mEC, EC31-HMI/ RTX 512PT	6ES7 677-1DD10-0BH0 S7-mEC, EC31-HMI/ RTX 2048PT
Test commissioning functions						
Status/control						
• Status/control variable		Yes	Yes	Yes	Yes	Yes
Forcing						
• Forcing		No	No	No	No	No
Diagnostic buffer						
• present		Yes	Yes	Yes	Yes	Yes
Ambient conditions						
Operating temperature						
• Min.	0 °C	0 °C	0 °C	0 °C	0 °C	0 °C
• max.	50 °C	50 °C	50 °C	50 °C	50 °C	50 °C
Configuration						
programming						
• Programming language						
- LAD		Yes	Yes	Yes	Yes	Yes
- FBD		Yes	Yes	Yes	Yes	Yes
- STL		Yes	Yes	Yes	Yes	Yes
- SCL		Yes	Yes	Yes	Yes	Yes
- CFC		Yes	Yes	Yes	Yes	Yes
- GRAPH		Yes	Yes	Yes	Yes	Yes
- HiGraph®		Yes	Yes	Yes	Yes	Yes
Dimensions						
Width	160 mm	160 mm	160 mm	160 mm	160 mm	160 mm
Height	125 mm	125 mm	125 mm	125 mm	125 mm	125 mm
Depth	115 mm	115 mm	115 mm	115 mm	115 mm	115 mm
Weight						
Weight, approx.	1.5 kg	1.5 kg	1.5 kg	1.5 kg	1.5 kg	1.5 kg

7

Embedded Controller

SIMATIC S7-modular Embedded Controller

EC31

Ordering data	Order No.	Order No.
SIMATIC S7-modular Embedded Controller EC31 Intel CoreDuo 1.2 GHz processor Memory configuration: 1 GB RAM, 4 GB Flash Disk; interfaces: 1 Industrial Ethernet port, 2 PROFINET ports, 2 USB ports, 1 slot for multimedia card; Software: Windows Embedded Standard pre-installed, Software Development Kit (SDK) for creating C/C++ applications with accesses to central I/O modules	6ES7 677-1DD10-0BA0	Accessories EM PCI-104 expansion module For fitting up to 3 additional PCI-104 cards EM PC expansion module Additional connection options: 2 USB interfaces, 1 Gigabit Ethernet interface, 1 serial interface, 1 slot for CF card, 1 slot for SD card/Micro Memory Card
EC31-RTX Intel CoreDuo 1.2 GHz processor Memory configuration: 1 GB RAM, 4 GB Flash Disk; interfaces: 1 Industrial Ethernet port, 2 PROFINET ports, 2 USB ports, 1 slot for multimedia card; Software: Windows Embedded Standard and WinAC RTX 2010 preinstalled	6ES7 677-1DD10-0BB0	6ES7 677-1DD60-1AA0
EC31-RTX F Intel CoreDuo 1.2 GHz processor Memory configuration: 1 GB RAM, 4 GB Flash Disk; interfaces: 1 Industrial Ethernet port, 2 PROFINET ports, 2 USB ports, 1 slot for multimedia card; Software: Windows Embedded Standard and WinAC RTX F 2010 preinstalled	6ES7 677-1FD10-0FB0	6ES7 677-1DD50-2AA0
EC31-HM/RTX Intel CoreDuo 1.2 GHz processor Memory configuration: 1 GB RAM, 4 GB Flash Disk; interfaces: 1 Industrial Ethernet port, 2 PROFINET ports, 2 USB ports, 1 slot for multimedia card; Software: Windows Embedded Standard, WinAC RTX 2010, SIMATIC SOFTNET-S7/V7.0 Lean preinstalled <ul style="list-style-type: none"> • With WinCC flexible 2008 RT 128 PT • With WinCC flexible 2008 RT 512 PT • With WinCC flexible 2008 RT 2048 PT 	6ES7 677-1DD10-0BF0 6ES7 677-1DD10-0BG0 6ES7 677-1DD10-0BH0	

7

Embedded Controller

SIMATIC S7-modular Embedded Controller

Expansion modules

Overview



- Expansion modules for SIMATIC S7-modular Embedded Controller EC31
 - EM PCI-104 for additionally accommodating up to 3 PCI-104 cards
 - EM PC with additional PC interfaces and slots for memory media

Technical specifications

	6ES7 677-1DD60-1AA0 EM PCI-104	6ES7 677-1DD50-2AA0 EM PC
General information		
Hardware product version	01	01
Input current		
from expansion bus	100 mA	580 mA
Power losses		
Power loss, typ.	2.4 W; Without inserted PCI-104 cards	9 W
Power loss, max.		14 W
Interfaces		
Number of USB interfaces	0	2
serial interface	0	1x V.24 (RS232)
Industrial Ethernet		
• Industrial Ethernet interface		Onboard, 10/100/1000 Mbit, RJ45
Ambient conditions		
Operating temperature		
• Min.	0 °C	0 °C
• max.	50 °C	50 °C
Dimensions		
Width	120 mm; Without bus connector Extension-Bus	80 mm; Without bus connector Extension-Bus
Height	125 mm; Without external voltage connecting terminal	125 mm
Depth	115 mm	115 mm
Weight		
Weight, approx.	0.5 kg	0.4 kg

Ordering data

EM PCI-104 expansion module

For fitting up to 3 additional PCI-104 cards

Order No.

6ES7 677-1DD60-1AA0

EM PC expansion module

Additional connection options:
1 DVI-I interface, 2 USB interfaces,
1 Gigabit Ethernet interface, 1 serial
interface, 1 slot for CF card, 1 slot
for SD card/Micro Memory Card

Order No.

6ES7 677-1DD50-2AA0

Overview



DP-M	DP-S	FMS	OPC	PG/OP	S7/S5
●	●	●	●	●	●

- PCI-104 interface card with own microprocessor for connecting embedded systems with PCI-104 interface to PROFIBUS at up to 12 Mbit/s
- Function compatible with CP 5613 A2
- Communication services:
 - PROFIBUS DP master Class 1 and 2 or DP slave according to IEC 61158/61784
 - PG/OP communication with STEP 5 and STEP 7
 - S7 communication with HARDNET-PB S7 software package
 - Open communication (SEND/RECEIVE) based on the FDL interface
 - PROFIBUS FMS according to IEC 61158/61784 with FMS-5613 software package
- Extensive diagnostics options for installation, commissioning and operation of the module
- Event and filter mechanism for reducing the load on the host CPU
- Multiprotocol operation and parallel operation of up to three CPs
- The appropriate OPC server and configuration tools are included in the scope of delivery of the respective communication software
- Linux-based development kit with driver sources for integration into "non-Windows" environments

Note:

FMS-5613 supports up to two CP 5603/CP 5613 A2/5614 A2/CP 5623/CP 5624 processors

Technical specifications

Order No.	6GK1 560-3AA00
Product-type designation	CP 5603
Transmission rate	
Transmission rate at interface 1 in accordance with PROFIBUS	9,6 kbit/s ... 12 Mbit/s
Interfaces	
Number of electrical connections at interface 1 in accordance with PROFIBUS	1
Design of electrical connection	
• at interface 1 in accordance with PROFIBUS	9-pin Sub-D socket (RS 485)
• of the backplane bus	PCI-104 (32Bit)
Supply voltage, current consumption, power loss	
Type of voltage of supply voltage	DC
Supply voltage 1 from backplane bus	5 V
Relative symmetrical tolerance at 5 V with DC	5 %
Consumed current 1 from backplane bus with DC maximum	0,66 A
Resistive loss	3.3 W

Order No.	6GK1 560-3AA00
Product-type designation	CP 5603
Permitted ambient conditions	
Ambient temperature	
• during operating	0 ... 70 °C
• during storage	-40 ... +70 °C
• during transport	-40 ... +70 °C
Relative humidity at 25 °C without condensation during operating maximum	85 %
Protection class IP	IP00
Design, dimensions and weight	
Module format	PCI-104
Width	90 mm
Height	21 mm
Depth	96 mm
Net weight	80 g
Type of mounting	Screw mounting

Embedded Controller Communication

CP 5603

Technical specifications (continued)

Order No.	6GK1 560-3AA00
Product-type designation	CP 5603
Product properties, functions, components general	
Number of plug-in cards in the same design can be plugged in per PC station	3
Number of modules note	FMS-5613 supports up to two CP 5603 / CP 5613 A2 / CP 5614 A2 / CP 5623 / CP 5624 processors
Performance data	
<u>Performance data open communication</u>	
Software for open communication by means of SEND/RECEIVE required	FDL driver included in scope of delivery of CP
Number of possible connections for open communication by means of SEND/RECEIVE maximum	80
<u>Performance data PROFIBUS DP</u>	
Software for DP master function required	No
Service as DP master	
• DPV0	Yes
• DPV1	Yes
• DPV2	Yes
Number of DP slaves on DP master usable	124
Amount of data	
• of the address area of the inputs as DP master overall	30 256 byte
• of the address area of the outputs as DP master overall	30 256 byte
• of the address area of the inputs per DP slave	244 byte
• of the address area of the outputs per DP slave	244 byte
• of the address area of the diagnostic data per DP slave	244 byte
Software for DP slave function required	No
Service as DP slave	
• DPV0	Yes
• DPV1	Yes
Amount of data	
• of the address area of the inputs as DP slave overall	244 byte
• of the address area of the outputs as DP slave overall	244 byte
<u>Performance data FMS functions</u>	
Software for FMS communication required	Yes, FMS-5613
Number of possible connections for FMS connection maximum	40
<u>Performance data S7 communication</u>	
Software for S7 communication required	Yes, HARDNET-S7 (S7-5613)
Number of possible connections for S7/PG communication maximum	50
<u>Performance data multi-protocol mode</u>	
Number of active connections with multiprotocol mode	50
Number of configurable connections per PC station	207

Order No.	6GK1 560-3AA00
Product-type designation	CP 5603
Product functions management, configuration	
Configuration software required	NCM PC included in scope of delivery
Product functions Diagnosis	
Product function Port diagnostics	Yes
Standards, specifications, approvals	
Standard	2004/108/EC
• for EMC	CAN/CSA C22.2 & UL 60950-1, UL 508
• for safety of CSA and UL	
• for emitted interference	EN 61000-6-3, EN 61000-6-4
• for interference immunity	EN 61000-6-1, EN 61000-6-2
Verification of suitability	
• CE mark	Yes
• C-Tick	Yes
Accessories	
Accessories	optional: Expansion rack for SIMATIC Microbox and slide-in plate for SIMATIC S7 modular embedded controller

Ordering data	Order No.	Order No.
CP 5603 communications processor PCI-104 card for connection to PROFIBUS incl. DP-Base software with NCM PC; DP-RAM interface for DP master or DP slave, incl. PG and FDL protocols; single license for one installation, runtime software, software and electronic manual on CD-ROM, Class A, for operating system support see SIMATIC NET software; German/English	6GK1 560-3AA00	HARDNET-PB DP Software for DP, incl. PG and FDL protocol, OPC server and NCM PC; runtime software, software and electronic manual on CD-ROM, license key on USB flash drive, Class A, for CP 5603, CP 5613 A2, CP 5623, CP 5614 A2, CP 5624;
Software Upgrade For CP 5603, CP 5613 A2 and CP 5623 to Edition 2008 or V8.1	6GK1 561-3AA01-3AE0	HARDNET-PB DP V8.2 for 32/64-bit: Windows 7 Professional/Ultimate; for 64-bit: Windows 2008 Server R2 German/English • Single License for one installation
CP 5603 Microbox Package For use of CP 5603 in Microbox 420/427B/427C; consisting of CP 5603 module and Microbox expansion frame	6GK1 560-3AU00	DP-5613 Edition 2008 for 32 Bit Windows XP Professional SP2/3; Windows 2003 Server R2, SP2; Windows Vista Business/Ultimate SP1; Windows 2008 Server; English/German • Single License for one installation
CP 5603 expansion rack For use in Microbox 420/427B/427C with mounting material	6GK1 560-3AA00-0AU0	Software Update Service For 1 year with automatic extension; requirement: current software version
CP 5603 mEC Package For use of CP 5603 in SIMATIC S7-MEC; consisting of CP 5603 and withdrawable unit for CP 5603 for installation in the EM PCI-104 expansion module of the SIMATIC S7-MEC	6GK1 560-3AE00	Upgrade • From Edition 2006 or 2007 to DP-5613 Edition 2008 or HARDNET-PB DP V8.1 • From V6.0, V6.1, V6.2 or V6.3 to DP-5613 Edition 2008 or HARDNET-PB DP V8.1
CP 5603 insert plate Metal plate with RS485 cutout for inserting for the S7 modular embedded controller	6GK1 560-3AA00-0AE0	
HARDNET-PB DP Development Kit HARDNET-PB DP Development Kit software for CP 5603, CP 5613, CP 5613 A2, CP 5623, CP 5613 FO, CP 5614, CP 5614 A2, CP 5624; for integration into other operating system environments on systems with a PCI slot	See http://www.siemens.com/simatic-net/dk5613	

Embedded Controller Communication

CP 5603

Ordering data	Order No.	Order No.
HARDNET-PB S7 Software for S7 communication, incl. PG and FDL protocol, OPC server and NCM PC; runtime software, software and electronic manual on USB flash drive, Class A, for CP 5603, CP 5613 A2, CP 5623, CP 5614 A2, CP 5624;		Software Update Service For 1 year with automatic extension; requirement: current software version
HARDNET-PB S7 V8.2 for 32/64-bit: Windows 7 Professional/Ultimate; for 64-bit: Windows 2008 Server R2 German/English • Single License for one installation	6GK1 713-5CB08-2AA0	Upgrade • From Edition 2006 or 2007 to FMS-5613 Edition 2008 • From V6.0, V6.1, V6.2 or V6.3 to FMS-5613 Edition 2008
S7-5613 Edition 2008 for 32 Bit Windows XP Professional SP2/3; Windows 2003 Server R2, SP2; Windows Vista Business/Ultimate SP1; Windows 2008 Server; English/German • Single License for one installation	6GK1 713-5CB71-3AA0	PROFIBUS FC Standard Cable GP Standard type with special design for quick assembly, 2-core, shielded, sold in meters; delivery unit max. 1000 m, minimum order 20 m
Software Update Service For 1 year with automatic extension; requirement: current software version	6GK1 713-5CB00-3AL0	PROFIBUS FastConnect bus connector RS485 Plug 180 With 180° cable outlet, insulation displacement
Upgrade • From Edition 2006 or 2007 to S7-5613 Edition 2008 or HARDNET-PB S7 V8.1 • From V6.0, V6.1, V6.2 or V6.3 to S7-5613 Edition 2008 or HARDNET-PB S7 V8.1	6GK1 713-5CB00-3AE0 6GK1 713-5CB00-3AE1	PROFIBUS bus terminal 12M Bus terminal for connection of PROFIBUS stations up to 12 Mbit/s with plug-in cable 1.5 m long
FMS-5613 Edition 2008 Software for FMS protocol incl. PG/OP communication; FDL, FMS-OPC server and NCM PC; runtime software, software and electronic manual on USB stick, Class A, for 32-bit Windows XP Professional SP2/3; Windows 2003 Server R2, SP2; Windows Vista Business/Ultimate SP1; Windows 2008 Server; for CP 5603, CP 5613, CP 5613 A2, CP 5623, CP 5613 FO, CP 5614, CP 5614 A2, CP 5624; German/English • Single License for one installation	6GK1 713-5FB71-3AA0	PROFIBUS FastConnect Stripping Tool Preset stripping tool for fast stripping of PROFIBUS FastConnect bus cables

7

Overview

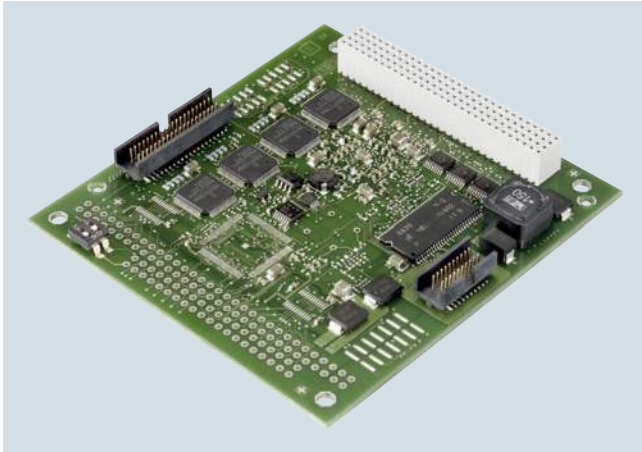

ISO	TCP/UDP	PN	MRP	OPC	PG/OP	S7/S5	IT
	●	●	●				

- PCI-104 module for connecting PCI-104 systems to PROFINET IO
- Full/half duplex with autonegotiation
- With Ethernet real-time ASIC ERTEC 400
- Integral 4-port real-time switch
- Communication services:
 - PROFINET IO controller and/or PROFINET IO device
 - Support of IRT in motion control applications
 - Support of PROFIenergy functionality
- High performance through direct memory access
- Integration in network management systems through the support of SNMP
- Comprehensive diagnostics possibilities for installation, start-up and operation of the module
- Powerful configuration tools are included in delivery of module

Technical specifications

Order No.	6GK1 160-4AA00
Product-type designation	CP 1604
Transmission rate	
Transfer rate at the interface 1	10 ... 100 Mbit/s
Interfaces	
Number of electrical connections	4
• at interface 1 in accordance with Industrial Ethernet	
• for power supply	1
Design of electrical connection	
• at interface 1 in accordance with Industrial Ethernet	RJ45 port via connection board
• of the backplane bus	PCI-104 (32Bit)
• for power supply	4-pin terminal block via power supply board
Supply voltage, current consumption, power loss	
Type of voltage of supply voltage	DC
Type of power supply optional external supply	Yes
Supply voltage	5 V
• 1 from backplane bus	24 V
• external	optional external power supply and external supply voltage alternatively via power supply board (optional accessory)
• note	
Relative symmetrical tolerance	
• at 5 V with DC	5 %
• at 24 V with DC	20 %
Consumed current	
• 1 from backplane bus with DC maximum	0,8 A
• from external supply voltage at 24 V at DC maximum	0.3 A
Resistive loss	4 W
• in switch mode maximum	4.1 W

Order No.	6GK1 160-4AA00
Product-type designation	CP 1604
Permitted ambient conditions	
Ambient temperature	
• during operating	5 ... 60 °C
• during storage	-20 ... +60 °C
• during transport	-20 ... +60 °C
Relative humidity at 25 °C without condensation during operating maximum	95 %
Protection class IP	IP00
Design, dimensions and weight	
Module format	
Width	90 mm
Height	24 mm
Depth	95 mm
Net weight	110 g
Product properties, functions, components general	
Number of plug-in cards in the same design can be plugged in per PC station	1
Number of modules note	-

Embedded Controller Communication

CP 1604

Technical specifications (continued)

Order No.	6GK1 160-4AA00
Product-type designation	CP 1604
Performance data	
<u>Performance data PROFINET communication as PN IO-Controller</u>	
Software for PROFINET IO communication required	No
Number of PN IO-Devices on PROFINET IO-Controller usable total	128
Number of PN IO IRT-Devices on PROFINET IO-Controller usable	64
Data volume	
• as useful data for input variables as PROFINET IO controller maximum	8 192 byte
• as useful data for output variables with PROFINET IO controller maximum	8 192 byte
• as useful data for input variables per PN IO device with PROFINET IO controller maximum	1 433 byte
• as useful data for output variables per PN IO device with PROFINET IO controller maximum	1 433 byte
<u>Performance data PROFINET communication as PN IO-Device</u>	
Amount of data	
• as useful data for input variables as PROFINET IO device maximum	1 433 byte
• as useful data for input variables as PROFINET IO device maximum	1 433 byte
• as useful data for input variables for each sub-module under PROFINET IO device	254 byte
• as useful data for input variables for each sub-module under PROFINET IO device	254 byte
• as useful data for the consistency area for each sub-module	254 byte
Number of submodules per PROFINET IO-Device	64
Product functions management, configuration	
Product function MIB support	Yes
Protocol is supported	
• SNMP v1	Yes
• DCP	Yes
• LLDP	Yes
Configuration software required	NCM PC included in scope of delivery
Identification & maintenance	
• I&M0 - device-specific information	Yes
• I&M1 - plant identification/location name	Yes
• I&M2 - installation date	Yes
• I&M3 - description	Yes
• I&M4 - signature	Yes

Order No.	6GK1 160-4AA00
Product-type designation	CP 1604
Product functions Diagnosis	
Product function	
• Web-based diagnostics	Yes
• Port diagnostics	Yes
Product functions switch	
Product feature switch	
Product function	Yes
• switch-managed	No
• for IRT PROFINET IO switch	Yes
Product functions Redundancy	
Product function	
• Ring redundancy	Yes
• Redundancy manager	Yes
• MRP redundancy protocol	Yes
Standards, specifications, approvals	
Standard	
• for EMC	2004/108/EC
• for safety of CSA and UL	CAN/CSA C22.2 & UL 60950-1
• for emitted interference	EN 61000-6-3, EN 61000-6-4
• for interference immunity	EN 61000-6-1, EN 61000-6-2
Verification of suitability	
• CE mark	Yes
• C-Tick	Yes
Accessories	
Accessories	optional: Connection board for CP 1604, power supply board for CP 1604, HARDNET-IE DK (development kit)

Ordering data	Order No.	Order No.
CP 1604 communications processor PCI-104 card (32-bit) with ASIC ERTEC 400 for connecting PCI-104 systems to PROFINET IO with 4-port real-time switch (RJ45); incl. IO-Base software for PROFINET IO-Controller and NCM PC; single license for one installation, runtime software, software and electronic manual on CD-ROM, Class A, for 32-bit Windows XP Professional and Windows 7; other operating systems using DK-16xx PN IO Development Kit German/English	6GK1 160-4AA01	Accessories Connection board for CP 1604 Connection board for CP 1604 with four RJ45 sockets incl. connecting cable 6GK1 160-4AC00
CP 1604 Microbox Package Package for implementing the CP 1604 in the SIMATIC Microbox PC; comprising the CP 1604, connection board, power supply and expansion racks for Microbox PC; for use with Development Kit DK-16xx PN IO; NCM PC	6GK1 160-4AU01	Power supply for CP 1604 Redundant power supply for CP 1604 for operating the integral 4-port switch of the CP 1604 with the PC-104 system switched off; includes connecting cable 6GK1 160-4AP00
		Development Kit DK-16xx PN IO Software Development Kit for CP 1616/CP 1604; driver and IO-Base software for CP 1616/CP 1604 as PN IO controller and PN IO device in source code for transfer to other PC-based operating systems; incl. executable sample code for SUSE Linux 10, Windows XP Professional and Windows 7 See http://www.siemens.com/simatic-net/dk16xx
		IE TP Cord RJ45/RJ45 TP cable 4 x 2 with 2 RJ45 connectors <ul style="list-style-type: none"> • 0.5 m • 1 m • 2 m • 6 m • 10 m 6XV1 870-3QE50 6XV1 870-3QH10 6XV1 870-3QH20 6XV1 870-3QH60 6XV1 870-3QN10
		SCALANCE X204IRT Managed Industrial Ethernet switches; isochronous real time, LED diagnostics, error signaling contact with SET button, redundant power supply 4 x 10/100 Mbit/s RJ45 ports 6GK5 204-0BA00-2BA3

Embedded Controller

Embedded bundles/Software packages

SIMATIC IPC227D bundles

Overview



- A quick start in automation solutions with embedded PC platforms
 - SIMATIC WinAC RTX or SIMATIC WinAC RTX F preinstalled on SIMATIC IPC227D and ready for use
 - PROFINET RT and Industrial Ethernet pre-configured for use in a SIMATIC environment
 - Optional WinCC RT Advanced for visualization tasks in parallel with SIMATIC WinAC RTX
 - Configuration and programming with SIMATIC STEP 7 via Industrial Ethernet or PROFINET
- Safety requirements up to SIL 3 in accordance with IEC 61508/62061 or EN ISO 13849-1 up to PL e can be implemented with WinAC RTX F.
- Rugged operation
 - Hard-disk-free operation with CompactFlash card (CF card) or solid-state drive and Windows Embedded Standard 2009 or Windows Embedded Standard 7, 32-bit
 - Fan-free operation
 - 128 KB of retentive data for WinAC RTX, also without uninterruptible power supply (UPS)
- Flexibility of a PC-based automation environment
 - Use of WinAC ODK with SIMATIC WinAC RTX or SIMATIC WinAC RTX F (read-only for fail-safe program section)
 - Connection option for USB devices, flat panel monitor or screen
 - PCIe cards can be plugged in

Ordering data

Order No.

Ordering data	Order No.
SIMATIC IPC227D	6ES7 647-8A-
Atom E620 (600 MHz), 512 MB RAM without drive, with CF Slot, COM1: RS232, without operating system, device version: Base, DIN rail, 1 x DVI-D graphics interface 2 x 10/100/1000 Mbit/s Ethernet RJ45 4 x USB V2.0 (high current) CompactFlash slot 24 V DC industrial power supply	
<u>Processors / memory configuration / NVRAM</u>	
• Atom E620 (600 MHz), 512 MB RAM	A
• Atom E620 (600 MHz), 512 MB RAM, NVRAM	B
• Atom E640 (1.0 GHz), 1 GB RAM	E
• Atom E640 (1.0 GHz), 1 GB RAM, NVRAM	F
• Atom E660 (1.3 GHz), 2 GB RAM	G
• Atom E660 (1.3 GHz), 2 GB RAM, NVRAM	H
<u>Drives</u>	
• Without drive, with CF slot	0
• 250 GB HDD SATA	1
• 50 GB Solid-State Drive SATA (High Endurance)	3
• 80 GB Solid-State Drive SATA (Standard)	4
• 2 GB SIMATIC IPC CompactFlash	5
• 4 GB SIMATIC IPC CompactFlash	6
• 8 GB SIMATIC IPC CompactFlash	7
• 16 GB SIMATIC IPC CompactFlash	8
<u>COM interface</u>	
• COM1: RS232	0
• COM1: RS485	1
• COM1: CAN	2
<u>Operating system</u>	
• Without operating system	0
• Windows Embedded Standard 2009 preinstalled (CF from 2 GB/SSD/HD)	1
• XP Prof. MUI preinstalled on SSD/HD	2
• Windows Embedded Standard 7 (32-bit) preinstalled (CF from 4 GB/SSD/HD)	3
• Windows 7 (32-bit) MUI preinstalled on SSD/HD	4

Embedded Controller

Embedded bundles/Software packages

SIMATIC IPC227D bundles

Ordering data	Order No.	Order No.
SIMATIC IPC227D (Fortsetzung) <u>Software bundles</u> • Without RTX/HMI software • RTX: WinAC RTX 2010 • RTX-F: WinAC RTX F 2010 • HMI: WinCC RT Advanced 128 PT • HMI: WinCC RT Advanced 512 PT • HMI: WinCC RT Advanced 2048 PT • HMI/RTX: RT 128 PT • HMI/RTX: RT 512 PT • HMI/RTX: RT 2048 PT • HMI/RTX-F: RT 128 PT • HMI/RTX-F: RT 512 PT • HMI/RTX-F: RT 2048 PT	6ES7 647-8A-	Accessories Cable strain relief set for IPC227D Packaging unit: 5 pcs. Dust protection set for IPC227D
<u>Device versions</u> • Device version: Basis • Device version: PCIe (1 slot) • Device version: COM (COM2-4: RS232) • Device version: IO (4x dig. in/out each)		6ES7 648-1AA50-0XL0 6ES7 648-1AA50-0XG0
<u>Mounting accessories</u> • Standard mounting rail • Wall mounting • Portrait mounting • Side mounting		
	A B C F G H M N P R S T A B D E 1 2 3 4	

Release for individual order variants: See releases in the ordering procedure.

Embedded Controller

Embedded bundles/Software packages

SIMATIC IPC427C bundles

Overview



Embedded PC platform with extremely high industrial compatibility for demanding tasks in the field of PC-based automation

- Rugged operation
 - Operation without a hard disk, based on CompactFlash card (CF Card) or solid-state drive and Windows Embedded Standard
 - Fan-free operation
 - 128 KB of retentive data for WinAC RTX, also without uninterruptible power supply (UPS)
- Flexibility of a PC-based automation environment
 - Free memory space on CF Card can be used for other PC applications
 - Use of WinAC ODK with SIMATIC WinAC RTX or SIMATIC WinAC RTX F (read-only for fail-safe program section)
 - Connection option for USB devices, flat panel monitor or screen
 - PCI 104 cards can be plugged in
- High-performance service concept
 - Replacement parts for preferred types available ex stock
- Safety requirements up to SIL 3 in accordance with IEC 61508/62061 or EN ISO 13849-1 up to PL e can be implemented with WinAC RTX F.
- Cost-effective versions with PROFINET, based on the standard Ethernet interface
- Current product versions of the pre-installed software:
 - SIMATIC WinAC RTX 2010 or SIMATIC WinAC RTX F 2010
 - SIMATIC WinCC flexible 2008 SP2 or WinCC RT Advanced
 - and the combinations of the software packages above
 - SIMATIC NET Edition 2008 or V8.1 (depending on operating system), as well as
 - SIMATIC WinCC V7.0 SP2 or WinCC RT Professional as a client / single station

Ordering data

Order No.

SIMATIC IPC427C bundles

RTX bundles with SIMATIC WinAC RTX (F) 2010

HMI bundles with WinCC flexible 2008 or WinCC RT Advanced V11 bundles

HMI/RTX bundles combining HMI and RTX

SIMATIC IPC427C with pre-installed software	6ES7 675-1D				
Processor					
• Celeron M, 1.2 GHz, 2x PROFINET (IE) ¹⁾		A			
• Celeron M, 1.2 GHz, 2x PROFINET (IE), 1x PROFIBUS ¹⁾		B			
• Core2 Solo, 1.2 GHz, 2x PROFINET (IE) ¹⁾		E			
• Core2 Solo, 1.2 GHz, 2x PROFINET (IE), 1x PROFIBUS ¹⁾		F			
• Core2 Solo, 1.2 GHz, 1x PROFINET (IE), PROFINET (RT/IRT) 3 ports		G			
• Core2 Duo, 1.2 GHz, 2x PROFINET (IE) ¹⁾		J			
• Core2 Duo, 1.2 GHz, 2x PROFINET (IE), 1x PROFIBUS ¹⁾		K			
• Core2 Duo, 1.2 GHz, 1x PROFINET (IE), PROFINET (RT/IRT) 3 ports		L			
Main memory					
• 1 GB RAM			2		
• 2 GB RAM ¹⁾			3		
• 4 GB RAM			4		
Operating system					
• Windows Embedded Standard 2009 (WES2009) ¹⁾			0		
• Windows Embedded Standard 7 (WES7) ²⁾			1		
Mass storage, internal					
• None (can only be ordered with externally accessible mass storage) ¹⁾				0	
• 250 GB HDD SATA, only additionally with externally accessible CF				1	
• 50 GB solid-state drive (high-endurance), operating system and software pre-installed				2	
• 80 GB solid-state drive (standard SATA), operating system and software pre-installed				3	
• 4 GB internal CompactFlash, operating system and software pre-installed ¹⁾				6	
• 8 GB internal CompactFlash, operating system and software pre-installed ¹⁾				7	
• 16 GB internal CompactFlash, operating system and software pre-installed ¹⁾				8	

¹⁾ Replacement hardware units available in exchange

²⁾ Only together from 2 GB main memory

7

Embedded Controller

Embedded bundles/Software packages

SIMATIC IPC427C bundles

Ordering data	Order No.		Order No.
<p>SIMATIC IPC427C with pre-installed software (continued)</p> <p>Externally accessible mass storage</p> <ul style="list-style-type: none"> • None (can only be ordered with internal mass storage) ¹⁾ • 4 GB CompactFlash, operating system and software pre-installed ¹⁾ • 8 GB CompactFlash, operating system and software pre-installed ¹⁾ • 16 GB internal CompactFlash, operating system and software pre-installed ¹⁾ <p>Software configurations ¹⁾</p> <ul style="list-style-type: none"> • WinAC RTX • HMI RT 128 PT • HMI RT 512 PT • HMI RT 2048 PT • HMI RT 4096 PT • WinAC RTX, HMI RT 128 PT • WinAC RTX, HMI RT 512 PT • WinAC RTX, HMI RT 2048 PT • WinAC RTX, HMI RT 4096 PT • WinAC RTX F • WinAC RTX F, HMI RT 128 PT • WinAC RTX F, HMI RT 512 PT • WinAC RTX F, HMI RT 2048 PT • WinAC RTX F, HMI RT 4096 PT • HMI RT: WinCC flexible 2008 SP2 or without HMI software • HMI RT: WinCC Advanced V11 SP2 (TIA Portal), only with WES7 and 2GB RAM 	<p>6ES7 675-1D </p>	<p>Bundles with WinCC</p> <p>("Built to order" with max. delivery time of 14 working days; only repairs are possible for hardware)</p> <p>IPC427C with WinCC RT, V7.0 SP2, incl. Update 1</p> <p>Fan-free, 4 x USB 2.0 (500 mA), 1 x COM (RS 232), 24 V DC power supply with On/Off switch, 2 x PROFINET (IE), Windows Embedded Standard 2009 pre-installed, SIMATIC WinCC V7.0 SP2 incl. Update1 Runtime pre-installed</p> <p>Client configurations</p> <p>Processor Celeron M 1.2 GHz, 1 GB SDRAM-DDR3, 4 GB CF Card, runtime license 128 PT</p> <p>Client and stand-alone station configurations</p> <ul style="list-style-type: none"> • Core2 Solo processor 1.2 GHz, 2 GB SDRAM-DDR3, 8 GB CF card, runtime license 128 PT²⁾ • Core2 Solo processor 1.2 GHz, PROFIBUS DP, 2 GB SDRAM-DDR3, 8 GB CF card, runtime license 128 PT²⁾ <p>Stand-alone station configurations</p> <p>Core2 Duo processor 1.2 GHz, PROFIBUS DP, 4 GB SDRAM-DDR3</p> <ul style="list-style-type: none"> • 8 GB CF card, runtime license 128 PT²⁾ • 50 GB SSD (High Endurance), runtime license 128 PT²⁾ • 8 GB CF card, runtime license 2048 PT²⁾ • 50 GB SSD (High Endurance), runtime license 2048 PT²⁾ 	<p>6ES7 675-1DA20-6AX0</p> <p>6ES7 675-1DE30-7AX0</p> <p>6ES7 675-1DF30-7AX0</p> <p>6ES7 675-1DK40-.A.0</p> <p>6ES7 675-1DK40-7AX0</p> <p>6ES7 675-1DK40-2AX0</p> <p>6ES7 675-1DK40-7AW0</p> <p>6ES7 675-1DK40-2AW0</p>
<p>In-stock models</p> <p>Replacement hardware units available in exchange</p> <p>SIMATIC IPC427C bundle with WinAC RTX 2010</p> <p>Core2 Solo processor, 1.2 GHz, 2x PROFINET (IE), 1x PROFIBUS, 2 GB RAM, 4 GB CompactFlash</p> <p>Core2 Duo processor, 1.2 GHz, 2x PROFINET (IE), 1x PROFIBUS, 2 GB RAM, 4 GB CompactFlash</p> <p>Core2 Duo processor, 1.2 GHz, 2x PROFINET (IE), 1x PROFIBUS, 2 GB RAM, 8 GB CompactFlash</p> <p>SIMATIC IPC427C bundle with WinAC RTX 2010 and WinCC flexible 2008 512 PT</p> <p>Core2 Duo processor, 1.2 GHz, 2x PROFINET (IE), 1x PROFIBUS, 2 GB RAM, 4 GB CompactFlash</p>	<p>6ES7 675-1DF30-0DB0</p> <p>6ES7 675-1DK30-0DB0</p> <p>6ES7 675-1DK30-0EP0</p> <p>6ES7 675-1DK30-0DL0</p>		

¹⁾ Replacement hardware units available in exchange

²⁾ Number of process tags (PT) can be increased by means of PowerPacks.



Embedded Controller

Embedded bundles/Software packages

SIMATIC IPC427C bundles

Ordering data

Order No.

Order No.

Bundles with WinCC RT Professional (TIA Portal)

("Built to order" with max. delivery time of 14 working days; only repairs are possible for hardware)

IPC427C with WinCC RT Professional, V11 SP2

Fan-free, 4 x USB 2.0 (500 mA), 1 x COM (RS 232), 24 V DC power supply with On/Off switch, 2 x PROFINET (IE), Windows Embedded Standard 7 SP1 pre-installed, SIMATIC WinCC Runtime Professional V11 SP2 pre-installed

Client configurations

6ES7 675-1DA31-7AY0

Celeron M processor 1.2 GHz, 2 GB SDRAM-DDR3, 8 GB CF card, runtime license 128 PT¹⁾

Client and stand-alone station configurations

- Core2 Solo processor 1.2 GHz, 2 GB SDRAM-DDR3, 8 GB CF card, runtime license 128 PT¹⁾
- Core2 Solo processor 1.2 GHz, PROFINET DP, 2 GB SDRAM-DDR3, 8 GB CF card, runtime license 128 PT¹⁾

6ES7 675-1DE31-7AY0

6ES7 675-1DF31-7AY0

Stand-alone station configurations

- Core2 Duo processor 1.2 GHz, PROFINET DP, 4 GB SDRAM-DDR3
- 8 GB CF card, runtime license 128 PT¹⁾
 - 50 GB SSD (High Endurance), runtime license 128 PT¹⁾
 - 8 GB CF card, runtime license 2048 PT¹⁾
 - 50 GB SSD (High Endurance), runtime license 2048 PT¹⁾

6ES7 675-1DK41-7AY0

6ES7 675-1DK41-2AY0

6ES7 675-1DK41-7AV0

6ES7 675-1DK41-2AV0

¹⁾ Number of process tags (PT) can be increased by means of PowerPacks.

Accessories

CP 5603 Microbox Package

6GK1 560-3AU00

Package for using the PROFIBUS CP 5603 in Microbox PCs; comprising a CP 5603 module and a Microbox expansion rack

CP 1604 Microbox Package

6GK1 160-4AU00

Package for using the PROFINET CP 1604 in Microbox PCs; comprising CP 1604, connection board, power supply and expansion rack for Microbox PC; implemented with Development Kit DK-16xx PN IO; NCM P

Portrait assembly kit

6ES7 648-1AA20-0YB0

Interfaces to the front

Expansion components

See catalog ST 80 / ST PC, Expansion components

Embedded Controller

Embedded bundles/Software packages

SIMATIC IPC277D bundles

Overview



SIMATIC IPC277D for implementing simple visualization and control tasks

- High degree of flexibility when selecting rugged widescreen fronts from 7" to 19" for more freely configurable display area
- High resolution, large viewing angle and up to 100% dimmable backlighting for brilliant display with optimized power consumption
- Absolutely maintenance-free due to the use of CompactFlash and SSD as mass storage and fanless operation up to 50 °C ambient temperature
- Maximum industrial functionality due to non-volatile retentive memory for battery-free operation
- Ready-to-run embedded bundles with visualization or/and control software

The following front installation versions are available:

- 7" Touch
- 9" Touch
- 12" Touch
- 15" Touch with front USB interface
- 19" Touch with front USB interface
- All fronts in widescreen design

Ordering data

Order No.

SIMATIC IPC277D Nanopanel PC

6AV7 881- A 0 0 - 0

Interfaces: 2 x Gbit LAN (RJ45),
1 x serial (COM1), 3 x USB

Operating unit

- Touch 7" TFT
- Touch 9" TFT
- Touch 12" TFT
- Touch 15" TFT, front USB interface
- Touch 19" TFT, front USB interface

1
2
3
4
5

Processors / memory configuration / NVRAM

- Atom E640 (1.0 GHz), 1 GB RAM
- Atom E640 (1.0 GHz), 1 GB RAM, NVRAM
- Atom E660 (1.3 GHz), 2 GB RAM
- Atom E660 (1.3 GHz), 2 GB RAM, NVRAM

A
B
E
F

Drives

- Without drive, with CF slot
- 2 GB SIMATIC PC CompactFlash
- 4 GB SIMATIC PC CompactFlash
- 8 GB SIMATIC PC CompactFlash
- 16 GB SIMATIC PC CompactFlash
- 50 GB Solid-State Drive SATA (High Endurance)
- 80 GB Solid-State Drive SATA (Standard)

0
1
2
3
4
7
8

Operating system

- Without operating system
- WES 2009 preinstalled (CF from 2 GB/SSD)
- XP-Prof. MUI preinstalled on SSD
- WES 7 32 bit preinstalled (CF from 4 GB/SSD)
- Windows 7 MUI 32 bit preinstalled on SSD

A
B
C
D
E

Software bundles

- Without RTX/HMI software
- RTX: WinAC RTX 2010
- RTX-F: WinAC RTX F 2010
- HMI: WinCC RT Advanced 128 PT
- HMI: WinCC RT Advanced 512 PT
- HMI: WinCC RT Advanced 2048 PT
- HMI/RTX: RT 128 PT
- HMI/RTX: RT 512 PT
- HMI/RTX: RT 2048 PT
- HMI/RTX-F: RT 128 PT
- HMI/RTX-F: RT 512 PT
- HMI/RTX-F: RT 2048 PT

A
B
C
F
G
H
M
N
P
R
S
T

Release for individual order variants: See releases in the ordering procedure.

Embedded Controller

Embedded bundles/Software packages

SIMATIC IPC277D bundles

Ordering data	Order No.		Order No.
Accessories			
Touch protective membranes 7" ¹⁾	6AV2 124-6GJ00-0AX0	Bracket clamp, long	6AV6 671-8XK00-0AX4
Touch protective membranes 9" ¹⁾	6AV2 124-6JJ00-0AX0	for 15", 19" and 22" widescreen, Comfort Panels, IPC, Flat Panel monitors and Thin Client (except SCD1900 19" widescreen)	
Touch protective membranes 12" ¹⁾	6AV2 124-6MJ00-0AX0	Touch pen	6AV7 672-1JB00-0AA0
Touch protective membranes 15" ¹⁾	6AV2 124-6QJ00-0AX0	Captive pen for operation of the touch devices, mounting of the support on the control cabinet or directly on the PRO unit	
Touch protective membranes 19" ¹⁾	6AV2 124-6UJ00-0AX0		

¹⁾ 10 units per packing unit

Please be sure to note:

The IPC277D with bundled software is always supplied with inserted CF card.
The licenses are on the supplied USB flash drive.

Embedded Controller

Embedded bundles/Software packages

SIMATIC HMI IPC477C bundles

Overview



Embedded PC platform with extremely high industrial compatibility for demanding tasks in the field of PC-based automation.

- Rugged operation
 - Operation without a hard disk, based on CompactFlash card (CF Card) or solid-state drive and Windows Embedded Standard
 - Fan-free operation
 - 128 KB of retentive data for WinAC RTX, also without uninterruptible power supply (UPS)
- Flexibility of a PC-based automation environment
 - Free memory space on CF Card can be used for other PC applications
 - Use of WinAC ODK with SIMATIC WinAC RTX or SIMATIC WinAC RTX F (read-only for fail-safe program section)
 - Connection option for USB devices, flat panel monitor or screen
- High-performance service concept
 - Replacement parts for preferred types available ex stock
- Safety requirements up to SIL 3 in accordance with IEC 61508/62061 or EN ISO 13849-1 up to PL e can be implemented with WinAC RTX F.
- Cost-effective versions with PROFINET, based on the standard Ethernet interface
- Product versions of the pre-installed software:
 - SIMATIC WinAC RTX 2010 or SIMATIC WinAC RTX F 2010
 - SIMATIC WinCC flexible 2008 or WinCC RT Advanced
 - and the combinations of the software packages above
 - SIMATIC NET Edition 2008 or V8.x (depending on operating system)
 - as well as
 - SIMATIC WinCC V7.0 SP2 or WinCC RT Professional as a client / single station

The following display versions are available:

- Built-in versions
 - 12" and 15" TFT Touch
 - 12" and 15" TFT Key
 - 19" Touch
- Support arm versions
 - PRO 15" and 19" Touch
 Fully-enclosed device to IP65 degree of protection for mounting on a support arm/stand.

Embedded Controller

Embedded bundles/Software packages

SIMATIC HMI IPC477C bundles

Technical specifications

	6AV7 884..	6AV7 883..PRO
General features		
Processors	Intel Celeron M 1.2 GHz, Intel Core2 Solo 1.2 GHz or Core2 Duo 1.2 GHz	Intel Celeron M 1.2 GHz, Intel Core2 Solo 1.2 GHz or Core2 Duo 1.2 GHz
Memory type	DDR3-RAM	DDR3-RAM
Main memory	1 GB, 2 GB or 4 GB	1 GB, 2 GB or 4 GB
Free slots	1 x CF card slot (externally accessible)	1 x CF card slot (externally accessible)
Operating system	Windows Embedded Standard 2009 (EN/DE) or Windows Embedded Standard 7	Windows Embedded Standard 2009 (EN/DE) or Windows Embedded Standard 7
Additional OS information	Language: EN/DE	Language: EN/DE
SIMATIC Software	Optionally with pre-installed software bundle, comprising SIMATIC WinCC flexible / WinCC RT Advanced and/or SIMATIC WinAC RTX / WinAC RTX F, SIMATIC WinCC or WinCC RT Professional as web client or single-user station	Optionally with pre-installed software bundle, comprising SIMATIC WinCC flexible / WinCC RT Advanced and/or SIMATIC WinAC RTX / WinAC RTX F, SIMATIC WinCC or WinCC RT Professional as web client or single-user station
Drives		
Disk drive	Optionally via external USB floppy disk drive	Optionally via external USB floppy disk drive
Optical drives	Possible as external drive via USB	Possible as external drive via USB
Hard drive/mass storage	CompactFlash drive with 2, 4, 8, or 16 GB and/or SSD with 50 GB (high endurance) or 80 GB (standard)	CompactFlash drive with 2, 4, 8, or 16 GB and/or SSD with 50 GB (High Endurance)
Interfaces		
Graphics interface	DVI-I for additional display unit: Color depth 32 bits	DVI-I for additional display unit: Color depth 32 bits
Connection for keyboard/mouse	USB / USB	USB / USB
Serial interface	COM1: 1 x V.24 (RS232)	COM1: 1 x V.24 (RS232)
PROFIBUS/MPI	Optionally onboard, isolated, max. 12 Mbit/s, no plug-in card required, CP5611-compatible, not upgradeable	Optionally onboard, isolated, max. 12 Mbit/s, no plug-in card required, CP5611-compatible, not upgradeable
PROFINET (RT/IRT)	Optional: 3 x RJ45, CP1616-compatible; not upgradeable	Optional: 3 x RJ45, CP1616-compatible; not upgradeable
USB	1 x on front, 4 x on rear, USB 2.0 (500 mA)	1 x on front, 4 x on rear, USB 2.0 (500 mA)
PROFINET (IE), Ethernet	onboard, 2 x 10/100/1000 Mbit (RJ45 with/without PROFIBUS), 1 x 10/100/1000 Mbit (RJ45 with PROFINET), no plug-in card required	onboard, 2 x 10/100/1000 Mbit (RJ45 with/without PROFIBUS), 1 x 10/100/1000 Mbit (RJ45 with PROFINET), no plug-in card required
Multimedia	No	No
Supply voltage		
Supply voltage	24 V DC	24 V DC
Monitoring functions		
Temperature	Yes	Yes
Watchdog	Yes	Yes
DiagBit (similar to S.M.A.R.T.)	Yes (for CF cards and SSD)	Yes (for CF cards and SSD)
Status LEDs	Yes (on rear)	Yes
Front side according to EN 60529	IP65 (on the front) according to EN 60529 and NEMA4	IP65 all around according to EN 60529 and NEMA4
Ambient conditions		
Vibration load during operation	Tested in accordance with DIN IEC 60068-2-6: 10 - 58 Hz: 0.075 mm, 58 to 200 Hz: 9.8 m/s ² (1 g)	Tested in accordance with DIN IEC 60068-2-6: 10 - 58 Hz: 0.075 mm, 58 to 200 Hz: 9.8 m/s ² (1 g)
Shock load during operation	Tested in accordance with DIN IEC 60068-2-7: 50 m/s ² (5 g), 30 ms, 100 shocks	Tested in accordance with DIN IEC 60068-2-7: 50 m/s ² (5 g), 30 ms, 100 shocks
Relative humidity	Tested in accordance with DIN IEC 60068-78, DIN IEC 60068-2-30: 5% to 80% at 25 °C (no condensation)	Tested in accordance with DIN IEC 60068-78, DIN IEC 60068-2-30: 5% to 80% at 25 °C (no condensation)
Maximum permissible installation angle +/-	30° over vertical	45° over vertical
Ambient temperature during operation	0 °C ... +50 °C in maximum configuration; no fan	15°: 0 °C ... +45 °C in maximum configuration; no fan 19°: 0 °C ... +40 °C in maximum configuration; no fan
Certifications & standards		
Approvals	CE, cULus(508), Marine	CE, cULus(508)
EMC	CE, 55022A, EN 61000-6-4, EN 61000-6-2	CE, 55022A, EN 61000-6-4, EN 61000-6-2

Embedded Controller

Embedded bundles/Software packages

SIMATIC HMI IPC477C bundles

Technical specifications (continued)

	6AV7 884-0	6AV7 884-1	6AV7 884-2	6AV7 884-3	6AV7 884-5	6AV7 883-6 (PRO)	6AV7 883-7 (PRO)
Front panel	12" TFT Touch	12" TFT Key	15" TFT Touch	15" TFT Key	19" TFT Touch	15" TFT Touch	19" TFT Touch
Display							
Resolution (W x H in pixels)	800 x 600	800 x 600	1024 x 768	1024 x 768	1280 x 1024	1024 x 768	1280 x 1024
MTBF of backlighting (at 25 °C)	50000 h at 24 h continuous operation, temperature-dependent	50000 h at 24 h continuous operation, temperature-dependent	50000 h at 24 h continuous operation, temperature-dependent	50000 h at 24 h continuous operation, temperature-dependent	50000 h at 24 h continuous operation, temperature-dependent	50000 h at 24 h continuous operation, temperature-dependent	50000 h at 24 h continuous operation, temperature-dependent
Type of operation							
Function keys	No	36	No	36	No	No	No
Alphanumeric keyboard	No	Yes	No	Yes	No	No	No
Touch screen (analog/resistive)	Yes	No	Yes	No	Yes	Yes	Yes
Mouse on front	No	Yes	No	Yes	No	No	No
Design							
Centralized configuration	Yes	Yes	Yes	Yes	Yes	Yes	Yes
Distributed configuration	No	No	No	No	No	No	No
Dimensions							
Mounting dimensions in centralized configuration (W x H x D, without optical drive) in mm	368 x 290 x 61	450 x 290 x 61	450 x 290 x 64	450 x 321 x 59	450 x 380 x 71	400 x 310 x 98	483 x 400 x 115
Operator control unit (W x H) in mm	400 x 310 (7 HU)	483 x 310 (19", 7 HU)	483 x 310 (19", 7 HU)	483 x 355 (19", 8 HU)	483 x 400 (19", 9 HU)	483 x 400 (19", 9 HU)	483 x 400 (19", 9 HU)
Weight	6.1 kg	6.6 kg	7.0 kg	6.6 kg	7.2 kg	7.4 kg	10.9 kg
General features							
Accessories	Touch protective membranes	Insertable strips for keyboard	Touch protective membranes	Insertable strips for keyboard	Touch protective membranes	Touch protective membranes	Touch protective membranes
Power loss in maximum configuration	24 V DC: max. 45 W	24 V DC: max. 45 W	24 V DC: max. 55 W	24 V DC: max. 55 W	24 V DC: max. 60 W	24 V DC: max. 55 W	24 V DC: max. 55 W

Embedded Controller

Embedded bundles/Software packages

SIMATIC HMI IPC477C bundles

Ordering data

Order No.

Order No.

SIMATIC HMI IPC477C bundles

RTX bundles with SIMATIC WinAC RTX (F) 2010

HMI bundles with WinCC flexible 2008 or WinCC RT Advanced bundles

HMI/RTX bundles combining HMI and RTX

("Built to order" version, max. delivery time of 15 working days and with identified repair, if not preferred type)

SIMATIC HMI IPC477C PRO	6AV7 883-	A						
Embedded and fan-free with fully enclosed IP65 enclosure 4 x USB (500 mA), 24 V DC power supply with On/Off switch								
SIMATIC HMI IPC477C	6AV7 884-	A						
Fan-free 5 x USB 2.0 (500 mA), one of which on the front 1 x COM (RS232) 24 V DC power supply with On/Off switch								
Front panels								
• 12" TFT Touch ¹⁾			0					
• 12" TFT Key			1					
• 15" TFT Touch ¹⁾			2					
• 15" TFT Key			3					
• 19" TFT Touch ¹⁾			5					
• 15" TFT Touch (IP65 enclosure; PRO)			6					
• 19" TFT Touch (IP65 enclosure; PRO)			7					
Processors and fieldbus								
• Celeron M 1.2 GHz, 2 x PROFINET (IE) ¹⁾		A						
• Celeron M 1.2 GHz, 2 x PROFINET (IE), 1 x PROFIBUS DP 12 ¹⁾		B						
• Core2 Solo 1.2 GHz, 2 x PROFINET (IE) ¹⁾		D						
• Core2 Solo 1.2 GHz, 2 x PROFINET (IE), 1 x PROFIBUS DP 12 ¹⁾		E						
• Core2 Solo 1.2 GHz, 1 x PROFINET (IE), 1 x PROFIBUS DP 12 ¹⁾		F						
• Core2 Duo 1.2 GHz, 2 x PROFINET (IE) ¹⁾		G						
• Core2 Duo 1.2 GHz, 2 x PROFINET (IE), 1 x PROFIBUS DP 12 ¹⁾		H						
• Core2 Duo 1.2 GHz, 1 x PROFINET (IE), 1 x PROFIBUS DP 12 ¹⁾		J						
Main memory (DDR3 RAM), 1 database								
• 1 GB			1					
• 2 GB ¹⁾			2					
• 4 GB			3					

Second mass storage (installed, CF replaceable)								
• None ¹⁾			0					
• CompactFlash 2 GB (only with Windows Embedded Standard 2009) ¹⁾			2					
• CompactFlash 4 GB ¹⁾			3					
• CompactFlash 8 GB ¹⁾			4					
• CompactFlash 16 GB ¹⁾			5					
• 50 GB SSD (High Endurance)			6					
• 80 GB SSD (Standard)			7					
Mass storage (installed, operating system pre-installed, optionally with SIMATIC software)								
• CompactFlash 2 GB ¹⁾				2				
• CompactFlash 4 GB ¹⁾				3				
• CompactFlash 8 GB ¹⁾				4				
• CompactFlash 16 GB ¹⁾				5				
• 50 GB SSD (High Endurance)				6				
• 80 GB SSD (Standard)				7				
Operating system								
• Windows Embedded Standard 2009, pre-installed ¹⁾						B A		
• Windows Embedded Standard 7 SP1, pre-installed ²⁾						E A		
Software packages, only with CF 4 GB or higher ¹⁾								
• with operating system and RTX pre-installed and configured						B		
• with operating system and HMI (incl. archives/recipes) pre-installed and configured							C D E F	
- Number of tags 128 PT								K
- Number of tags 512 PT								L
- Number of tags 2048 PT								M
- Number of tags 4096 PT								N P
• with operating system and HMI/RTX (incl. archives/recipes) pre-installed and configured								R S T U
- Number of tags 128 PT								0
- Number of tags 512 PT								1
- Number of tags 2048 PT								
- Number of tags 4096 PT								
• HMI RT: WinCC flexible 2008 or no HMI software								
• HMI RT: WinCC Advanced V11 SP2 (TIA Portal), only with WES7 SP1 and 2 GB RAM								

¹⁾ Preferred versions with repaired replacement device from warehouse

²⁾ Only together from 2 GB main memory

7

Embedded Controller

Embedded bundles/Software packages

SIMATIC HMI IPC477C bundles

Ordering data

Order No.

Order No.

Bundles with WinCC RT Professional (TIA Portal)

("Built to order" with max. delivery time of 14 working days; only repairs are possible for hardware)

SIMATIC HMI IPC477C Fan-free 4 x USB 2.0 on rear, 1 x USB 2.0 on front, 1 x COM (RS232), 2 x 10/100/1000 Mbit/s Ethernet (RJ45); software pre-installed on CF/SSD: Windows Embedded Standard 7 SP1, SIMATIC WinCC Professional V11 SP2	6AV7 884- A 0 - E 0
SIMATIC HMI IPC477C PRO Fan-free, 4 x USB 2.0 (500 mA), 1 x USB 2.0 on front (except PRO), 1 x COM (RS 232), 24 V DC power supply with On/Off switch, 2 x PROFINET (IE), Windows Embedded Standard 7 SP1 pre-installed, SIMATIC WinCC Professional V11 SP2	6AV7 883- A 0 - E 0
Front panel • 15" TFT Touch • 19" TFT Touch • 15" TFT Touch PRO • 19" TFT Touch PRO	6AV7 884- 2 6AV7 884- 5 6AV7 883- 6 6AV7 883- 7
Client configurations Celeron M processor 1.2 GHz, 1 GB DDR3 RAM, 4 GB CF card, runtime license 128 PT	A 2 4 Y
Client and stand-alone station configurations Core2 Solo processor 1.2 GHz, 2 GB SDRAM-DDR3, 8 GB CF card, runtime license 128 PT	D 2 4 Y
Core2 Solo processor 1.2 GHz, PROFIBUS DP, 2 GB SDRAM-DDR3, 8 GB CF card, runtime license 128 PT	E 2 4 Y
Stand-alone station configurations	
SIMATIC HMI IPC477C	6AV7 884- A H 3 0 - E 0
SIMATIC HMI IPC477C PRO Core2 Duo processor 1.2 GHz, PROFIBUS DP, 4 GB SDRAM-DDR3 • 8 GB CF card • 50 GB SSD (High Endurance) • Runtime license 128 PT • Runtime license 2048 PT	6AV7 883- A H 3 0 - E 0 4 6 Y V

Bundles with WinCC V7.0 SP2 incl. Update 1

("Built to order" with max. delivery time of 14 working days; only repairs are possible for hardware)

SIMATIC HMI IPC477C Fan-free 4 x USB 2.0 on rear, 1 x USB 2.0 on front, 1 x COM (RS232), 2 x 10/100/1000 Mbit/s Ethernet (RJ45); software pre-installed on CF/SSD: Windows Embedded Standard, SIMATIC WinCC V7.0 SP1	6AV7 884- A 0 - B 0
SIMATIC HMI IPC477C PRO Fan-free, 4 x USB 2.0 (500 mA), 1 x USB 2.0 on front (not on PRO), 1 x COM (RS 232), 24 V DC power supply with On/Off switch, 2 x PROFINET (IE), Windows Embedded 2009 pre-installed SIMATIC WinCC V7.0 SP2 incl. Update 1 Runtime pre-installed	6AV7 883- A 0 - B 0
Front panel • 15" TFT Touch • 19" TFT Touch • 15" TFT Touch PRO • 19" TFT Touch PRO	6AV7 884- 2 6AV7 884- 5 6AV7 883- 6 6AV7 883- 7
Client configurations Celeron M processor 1.2 GHz, 1 GB DDR3 RAM, 4 GB CF card, runtime license 128 PT	A 1 3 X
Client and stand-alone station configurations Core2 Solo processor 1.2 GHz, 2 GB SDRAM-DDR3, 8 GB CF card, runtime license 128 PT	D 2 4 X
Core2 Solo processor 1.2 GHz, PROFIBUS DP, 2 GB SDRAM-DDR3, 8 GB CF card, runtime license 128 PT	E 2 4 X
Stand-alone station configurations	
SIMATIC HMI IPC477C	6AV7 884- A H 3 0 - B 0
SIMATIC HMI IPC477C PRO Core2 Duo processor 1.2 GHz, PROFIBUS DP, 4 GB SDRAM-DDR3 • 8 GB CF card • 50 GB SSD (High Endurance) • Runtime license 128 PT • Runtime license 2048 PT	6AV7 883- A H 3 0 - B 0 4 6 X W

Note:

Other ready-to-use SIMATIC HMI IPC477Cs can be found in the Panel PC chapter under HMI IPC477C.

Embedded Controller

Embedded bundles/Software packages

SIMATIC HMI IPC477C bundles

Ordering data	Order No.	Order No.
Accessories Protective film for Panel PCs 477/577/677 For protecting the touch screen against dirt/scratches <ul style="list-style-type: none"> • for 12" Touch • for 15" Touch (not for PRO) • for 19" Touch 	6AV7 671-2BA00-0AA0 6AV7 671-4BA00-0AA0 6AV7 672-1CE00-0AA0	Labeling membranes for Panel PCs 477/577/677 For labeling soft keys and function keys, blank, supplied in sets of 10 6AV7 672-0DA00-0AA0
		Touch pen Captive pen for operation of the touch devices; holder can be mounted on the control cabinet or direct on the PRO unit 6AV7 672-1JB00-0AA0
		Expansion components See Expansion components, catalog ST 80 / ST PC

Please be sure to note:

The HMI IPC477C is delivered as standard with an inserted CF card. The licenses are located on the supplied USB flash drive.

Embedded Controller

Embedded bundles/Software packages

Software packages for SIMATIC IPC and S7-mEC

Overview

HMI complete systems

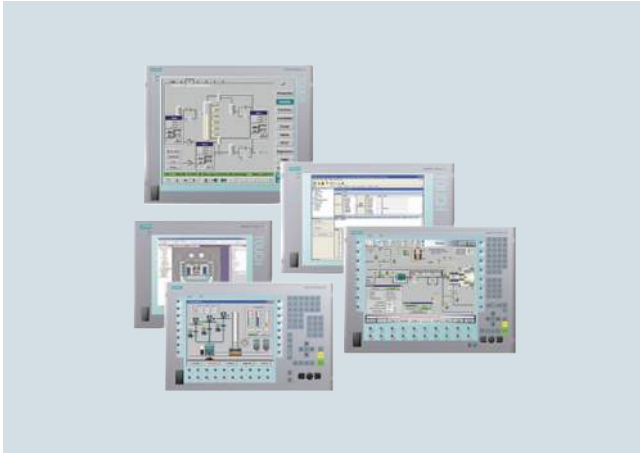

SIMATIC IPC and S7-mEC with SIMATIC WinCC flexible

- SIMATIC IPC packages with WinCC flexible are an innovative solution for simple visualization tasks directly at the machine in the field of HMI.
- This package can only be supplied if a SIMATIC IPC or S7-mEC (same quantity) is ordered together with the WinCC flexible Runtime software. It cannot be ordered subsequently.
- In combination with the embedded SIMATIC IPC (HMI IPC477C (PRO) and IPC427C) and the embedded controller S7-mEC, there are turn-key solutions (bundles), i.e. the runtime software is already preinstalled.

SIMATIC IPC with SIMATIC WinCC (TIA Portal)

- The SIMATIC IPC packages with WinCC make it easy to order all the components required for an HMI solution on the basis of a Panel PC.
- This package can only be supplied if a SIMATIC IPC or S7-mEC (same quantity) is ordered together with the WinCC flexible Runtime software. It cannot be ordered subsequently.
- In combination with the embedded SIMATIC IPC (HMI IPC477C (PRO) and IPC427C) and the embedded controller S7-mEC, there are turn-key solutions (bundles), i.e. the runtime software is already preinstalled.

SIMATIC IPC with SIMATIC WinAC RTX (F)

- The SIMATIC IPC packages with WinAC RTX make it easy to order all the components required for a control solution on the basis of an industrial PC.
- This package can only be supplied if a SIMATIC Industrial PC (same quantity) is ordered together with the WinAC RTX Runtime software. It cannot be ordered subsequently.
- In combination with the embedded SIMATIC IPC (HMI IPC477C (PRO) and IPC427C) and the embedded controller S7-mEC, there are turn-key solutions (bundles), i.e. the runtime software is already preinstalled.

Ordering data

Order No.

SIMATIC WinCC flexible package ¹⁾³⁾ (incl. archives and recipes)

WinCC flexible 2008 Runtime

- 128 PowerTags
- 512 PowerTags
- 2048 PowerTags
- 4096 PowerTags

6AV6 623- 2 A 0 0 - 0 A A 0

B
D
F
G

SIMATIC WinCC package ²⁾

WinCC V6.2 SP3 Runtime ²⁾

- 128 PowerTags
- 256 Power Tags
- 1024 Power Tags
- 8192 PowerTags
- 65536 PowerTags

6AV6 382- 2 A 0 6 - 2 A X 0

C
D
E
H
F

SIMATIC WinCC package ²⁾

WinCC V7.0 SP2 Runtime ²⁾

- 128 PowerTags
- 512 PowerTags
- 2048 PowerTags
- 8192 PowerTags
- 65536 PowerTags

6AV6 382- 2 A 0 7 - 2 A X 0

C
D
E
H
F

¹⁾ Only if ordered together with a SIMATIC IPC, SIMATIC Panel PC Ex, or S7-mEC

²⁾ Only if ordered together with a SIMATIC IPC

³⁾ The current version will always be supplied

SIMATIC WinCC (TIA Portal)

WinCC Runtime Advanced Package ¹⁾³⁾

Incl. Recipes + Logging

- 128 PowerTags
- 512 PowerTags
- 2048 PowerTags
- 4096 PowerTags

6AV2 114- 2 A 0 0 - 0 A A 0

B
D
F
H

SIMATIC WinCC Runtime Professional Package ²⁾³⁾

- 128 PowerTags
- 512 PowerTags
- 2048 PowerTags
- 4096 PowerTags
- 8192 PowerTags
- 65536 PowerTags

6AV2 115- 2 A 0 0 - 0 A A 0

B
D
F
H
K
M

¹⁾ Only if ordered together with a SIMATIC IPC, SIMATIC Panel PC Ex, or S7-mEC

²⁾ Only if ordered together with a SIMATIC IPC

³⁾ The current version will always be supplied

SIMATIC WinAC RTX (F) package

- SIMATIC WinAC RTX ²⁾³⁾
- SIMATIC WinAC RTX F ²⁾³⁾

6ES7 671-0RC08-6YA0
6ES7 671-1RC08-6YA0

¹⁾ Only if ordered together with a SIMATIC IPC or S7-mEC

²⁾ Only if ordered together with a SIMATIC IPC

³⁾ The current version will always be supplied

Note:

For ordering data for Panel PCs and accessories, see configurators in "SIMATIC Panel PCs".

Embedded Controller

Embedded bundles/Software packages

Software packages for SIMATIC IPC and S7-mEC

Ordering data

Order No.

Ready-to-use HMI IPC477C with WinCC

("Built to order" with max. delivery time of 14 working days; only repairs are possible for hardware)

<p>HMI IPC477C with WinCC V7.0</p> <p>No fan, 5 x USB2.0 (500 mA), 1 x of which on front, 1 x COM (RS 232), 24 V DC power supply with On/Off switch, 2 x PROFINET (IE), 2 GB main memory (DDR3-SDRAM), CompactFlash Card 8 GB; Windows Embedded 2009 preinstalled; SIMATIC WinCC V7.0 SP2 Runtime preinstalled</p>	<p>6AV7 884- A - 0 - B 0</p>
<p>Client configurations</p> <p>Celeron M processor, 1.2 GHz, 1 GB SDRAM-DDR3, 8 GB CF card, runtime license 128 PT</p> <ul style="list-style-type: none"> • 15" Touch • 19" Touch 	<p>A A 1 0 - 4 B X 0</p> <p>3 5</p>
<p>Client and stand-alone station configurations</p> <p>Core2 Solo processor 1.2 GHz, 2 GB SDRAM-DDR3, 8 GB CF card, runtime license 128 PT</p> <ul style="list-style-type: none"> • 15" Touch • 19" Touch 	<p>A E 2 0 - 4 B X 0</p> <p>3 5</p>
<p>Stand-alone station configurations</p> <p>Processor Core2 Duo 1.2 GHz, 4 GB SDRAM-DDR3</p> <ul style="list-style-type: none"> • 15" Touch • 19" Touch • 8 GB CF card • 50 GB SSD • Runtime license 128 PT • Runtime license 2048 PT 	<p>A H 3 0 - B 0</p> <p>3 5</p> <p>A H 3 0 - 4 A H 3 0 - 6 A H 3 0 - B X 0 A H 3 0 - B W 0</p>

Order No.

HMI IPC477C / HMI IPC477C PRO with WinCC RT Professional (TIA Portal)

("Built to order" with max. delivery time of 14 working days; only repairs are possible for hardware)

<p>HMI IPC477C with WinCC RT Professional (TIA Portal)</p>	<p>6AV7 884 - A - 0 - E 0</p>
<p>HMI IPC477C PRO with WinCC RT Professional (TIA Portal)</p> <p>No fan, 5 x USB2.0 (500 mA), 1 x of which on front, 1 x COM (RS 232), 24 V DC power supply with On/Off switch, 2 x PROFINET (IE), 2 GB main memory (DDR3-SDRAM), CompactFlash card 8 GB; Windows Embedded Standard 7 SP1 preinstalled; SIMATIC WinCC RT Professional V11 SP2 preinstalled</p>	<p>6AV7 883 - A - 0 - E 0</p>
<p>Operator panels</p> <ul style="list-style-type: none"> • 15" Touch • 15" Touch PRO • 19" Touch • 19" Touch PRO 	<p>4 3 3 6 4 5 3 7</p>
<p>Client configurations</p> <p>Celeron M processor, 1.2 GHz, 2 GB SDRAM-DDR3, 8 GB CF card, runtime license 128 PT</p>	<p>A A 2 0 - 4 E Y 0</p>
<p>Client and stand-alone station configurations</p> <p>Core2 Solo processor 1.2 GHz, 2 GB SDRAM-DDR3, 8 GB CF card, runtime license 128 PT</p>	<p>4 - A A 2 0 - 4 E Y 0</p>
<p>Stand-alone station configurations</p> <p>Processor Core2 Duo 1.2 GHz, 4 GB SDRAM-DDR3</p> <ul style="list-style-type: none"> • 8 GB CF card • 50 GB SSD • Runtime license 128 PT • Runtime license 2048 PT 	<p>4 - A H 3 0 - E 0</p> <p>A H 3 0 - 4 E 0 6 A H 3 0 - E Y 0 V</p>

Note:

Other ready-to-use SIMATIC HMI IPC477Cs can be found in the Panel PC chapter under HMI IPC477C.

SIMATIC PC-based controllers



8/2

8/2

8/8

8/14

SIMATIC PC-based controllers

SIMATIC WinAC RTX

SIMATIC WinAC RTX F

SIMATIC WinAC ODK

Brochures

For brochures serving as selection guides for SIMATIC products refer to:

www.siemens.com/simatic/printmaterial

SIMATIC PC-based controllers

SIMATIC PC-based controllers

SIMATIC WinAC RTX

Overview

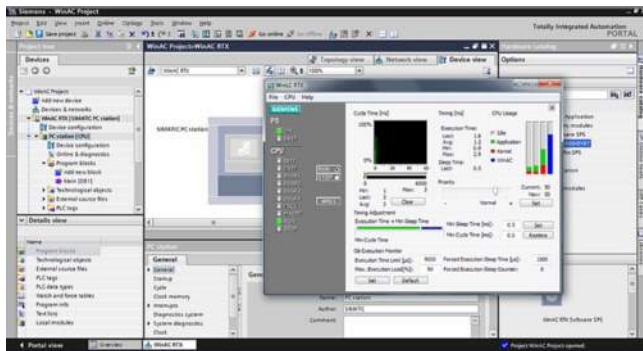

- SIMATIC WinAC RTX: Optimized for applications that require a high degree of flexibility and integration capability.
- The software solution for tasks that require hard deterministic behavior and high performance.
- With real-time expansion for assuring deterministic behavior for the control section.

New with WinAC RTX 2010:

- Operation under Windows 7
- Web server
- New PROFINET functions:
 - Isochronous mode
 - Shared Device
 - Media redundancy
 - IP configuration

Technical specifications

	6ES7 671-0RC08-0YA0 SIMATIC WinAC RTX 2010
General information	
Hardware product version	-
Firmware version	V4.6
Engineering with	
• Programming package	STEP7 as of V5.5 + HW update / iMap V3.0 SP1
Memory	
Work memory	
• integrated (for program)	4 Mbyte; Adjustable; depends on Non Paged Memory Pool
• integrated (for data)	4 Mbyte; Adjustable; depends on Non Paged Memory Pool
Load memory	
• integrated RAM, max.	8 Mbyte; Adjustable; depends on Non Paged Memory Pool
CPU processing times	
for bit operations, typ.	0.004 µs; typ.
for fixed point arithmetic, typ.	0.003 µs; typ.
for floating point arithmetic, typ.	0.004 µs; typ.
Reference platform	Pentium IV, 2.4 GHz
CPU-blocks	
DB	
• Number, max.	65 535; Limited only by RAM set for data
• Size, max.	64 kbyte
FB	
• Number, max.	65 536; Limited only by RAM set for code
• Size, max.	64 kbyte
FC	
• Number, max.	65 536; Limited only by RAM set for code
• Size, max.	64 kbyte
OB	
• Size, max.	64 kbyte
Nesting depth	
• per priority class	24
• additional within an error OB	24

	6ES7 671-0RC08-0YA0 SIMATIC WinAC RTX 2010
Counters, timers and their retentivity	
S7 counter	
• Number	2 048
• Retentivity	
- adjustable	Yes
- lower limit	0
- upper limit	2 047
- preset	8
• Counting range	
- adjustable	Yes
- lower limit	0
- upper limit	999
IEC counter	
• present	Yes
• Type	SFB
• Number	Unlimited (limited only by RAM capacity)
S7 times	
• Number	2 048
• Retentivity	
- adjustable	Yes
- lower limit	0
- upper limit	2 047
- preset	0
• Time range	
- lower limit	10 ms
- upper limit	9 990 s
IEC timer	
• present	Yes
• Type	SFB
• Number	Unlimited (limited only by RAM capacity)

Technical specifications (continued)

6ES7 671-0RC08-0YA0 SIMATIC WinAC RTX 2010	
Data areas and their retentivity	
Retentivity without UPS and PS Extension Board	128 kbyte with SIMATIC IPC427C and HMI IPC477C; further SIMATIC PCs on request
Retentivity with UPS	all data
Flag	
• Number, max.	16 kbyte
• Retentivity preset	MB 0 to MB 15
• Number of clock memories	8
Data blocks	
• Retentivity adjustable	Yes; via non-retain property on DB
• Retentivity preset	Yes
Local data	
• adjustable, max.	64 kbyte
• preset	32 kbyte
• per priority class, max.	61 440 byte
Address area	
I/O address area	
• Inputs	16 kbyte
• Outputs	16 kbyte
• of which, distributed	
- DP interface, inputs	16 kbyte
- DP interface, outputs	16 kbyte
- PN interface, inputs	16 kbyte
- PN interface, outputs	16 kbyte
Process image	
• Inputs, adjustable	8 kbyte
• Outputs, adjustable	8 kbyte
• Inputs, default	512 byte
• Outputs, default	512 byte
Subprocess images	
• Number of subprocess images, max.	15
Digital channels	
• Inputs	128 000
• Outputs	128 000
Analog channels	
• Inputs	8 000
• Outputs	8 000
Hardware configuration	
Submodules	
• Number of submodules, max	4
• of which PROFIBUS, max.	4; Supported interfaces: see 1st and 2nd interface
• of which Industrial Ethernet, max.	1; Supported interfaces: see 3rd and 4th interface
Number of operable FMs and CPs (recommended)	
• FM	FM distributed: FM 350-1 / 350-2, FM 351, FM 352, FM 353, FM 355 / 355-2
• CP, point-to-point	2; CP 340, CP 341 distributed
• CP, LAN	Over PC CP

6ES7 671-0RC08-0YA0 SIMATIC WinAC RTX 2010	
Time of day	
Clock	
• Hardware clock (real-time clock)	Yes
• battery-backed and synchronizable	Yes
Operating hours counter	
• Number	8
Clock synchronization	
• supported	Yes
• to PC-CP, slave	Yes
• on Ethernet via NTP	Yes
Interfaces	
Number of USB interfaces	0
1st interface	
Type of interface	CP 5611-A2, CP 5621, integrated PB interface of the SIMATIC PC
Max. no. of simultaneously operable CPs	1
Physics	RS 485 / PROFIBUS
Isolated	Yes
Power supply to interface (15 to 30 V DC), max.	does not exist
Number of connection resources	8
Functionality	
• MPI	No
• DP master	Yes
• DP slave	No
DP master	
• Number of connections, max.	8
• Transmission rate, max.	12 Mbit/s
• Number of DP slaves, max.	64
• Services	
- PG/OP communication	Yes
- Global data communication	No
- S7 basic communication	No
- S7 communication	Yes
- S7 communication, as client	Yes
- S7 communication, as server	Yes
- Equidistance mode support	Yes; Only in conjunction with isochronous mode
- Isochronous mode	Yes
- SYNC/FREEZE	Yes
- Activation/deactivation of DP slaves	Yes
- Direct data exchange (slave-to-slave communication)	Yes
- DPV1	Yes
• Address area	
- Inputs, max.	16 kbyte
- Outputs, max.	16 kbyte
• User data per DP slave	
- Inputs, max.	244 byte
- Outputs, max.	244 byte

SIMATIC PC-based controllers

SIMATIC PC-based controllers

SIMATIC WinAC RTX

Technical specifications (continued)

6ES7 671-0RC08-0YA0 SIMATIC WinAC RTX 2010	
2nd interface	
Type of interface	CP 5613, CP 5613-A2, CP 5603
Max. no. of simultaneously operable CPs	4
Physics	RS 485 / PROFIBUS
Isolated	Yes
Functionality	
• MPI	No
• DP master	Yes
• DP slave	No
DP master	
• Number of connections, max.	50
• Transmission rate, max.	12 Mbit/s
• Number of DP slaves, max.	125
• Services	
- PG/OP communication	Yes
- Global data communication	No
- S7 basic communication	No
- S7 communication	Yes
- S7 communication, as client	Yes
- S7 communication, as server	Yes
- Equidistance mode support	Yes; Only in conjunction with isochronous mode
- Isochronous mode	Yes
- SYNC/FREEZE	Yes
- Activation/deactivation of DP slaves	Yes
- Direct data exchange (slave-to-slave communication)	Yes
- DPV1	Yes
• Address area	
- Inputs, max.	16 kbyte
- Outputs, max.	16 kbyte
• User data per DP slave	
- Inputs, max.	244 byte
- Outputs, max.	244 byte
3rd interface	
Type of interface	PROFINET
Max. no. of simultaneously operable CPs	1; Intel Pro/1000 (Intel 82571EB, 82573L, 82574L, 82541PI; non-shared IRQ required); integrated IE interface SIMATIC PC 4x7B, 6x7B, 8x7B, IPC4x7C, IPC6x7C, IPC8x7C
Physics	Ethernet
Isolated	Yes
Integrated switch	No
Number of ports	1
Automatic detection of transmission speed	Yes; 10/100 Mbit/s
Autonegotiation	Yes
Autocrossing	Yes
Media redundancy	
• supported	No

6ES7 671-0RC08-0YA0 SIMATIC WinAC RTX 2010	
Functionality	
• PROFINET IO Controller	Yes
• PROFINET IO Device	No
• PROFINET CBA	Yes
PROFINET IO Controller	
• Transmission rate, min.	100 Mbit/s
• Transmission rate, max.	100 Mbit/s
• Max. number of connectable IO devices for RT	128
- of which in line, max.	128
• IRT, supported	No
• Prioritized startup supported	Yes
- Number of IO Devices, max.	32
• Activation/deactivation of IO Devices	Yes
- Maximum number of IO devices that can be activated/deactivated at the same time.	8
• IO Devices changing during operation (partner ports), supported	Yes
• Device replacement without swap medium	Yes
• Send cycles	1 ms
• Updating time	1 - 512 ms (minimum value depends on communication share set for PROFINET I/O, on the number of I/O devices, and on the volume of configured user data)
• Services	
- PG/OP communication	Yes
- S7 communication	Yes
- Isochronous mode	No
- Open IE communication	Yes
• Address area	
- Inputs, max.	16 kbyte
- Outputs, max.	16 kbyte
- User data per address area, max.	2 kbyte
- User data consistency, max.	256 byte
Open IE communication	
• Open IE communication, supported	Yes
• Number of connections, max.	32
• Local port numbers used at the system end	0, 20, 21, 23, 25, 80, 102, 135, 161, 8080, 34962, 34963, 34964, 65532, 65533, 65534, 65535
• Keep-alive function, supported	Yes
4th interface	
Type of interface	PROFINET
Max. no. of simultaneously operable CPs	1; CP 1616 (HW release 8 or above), CP 1604 (HW release 7 or higher), integrated PN interface of SIMATIC PC and S7-mEC
Physics	Ethernet
Isolated	Yes
Integrated switch	Yes
Number of ports	3
Automatic detection of transmission speed	Yes; 10/100 Mbit/s

Technical specifications (continued)

6ES7 671-0RC08-0YA0 SIMATIC WinAC RTX 2010	
Autonegotiation	Yes
Autocrossing	Yes
Change of IP address at runtime, supported	Yes
Number of connection resources	32
Media redundancy	
• supported	Yes
• Switchover time on line break, typically	200 ms
• Number of stations in the ring, max.	50
Functionality	
• PROFINET IO Controller	Yes
• PROFINET IO Device	No
• PROFINET CBA	Yes
PROFINET IO Controller	
• Transmission rate, max.	100 Mbit/s
• Max. number of connectable IO Devices for RT	256
- of which in line, max.	256
• Number of IO devices with IRT and the option "high flexibility"	64
- of which in line, max.	32
• Number of IO Devices with IRT and the option "high performance", max.	64
- of which in line, max.	32
• IRT, supported	Yes
• Prioritized startup supported	Yes
- Number of IO Devices, max.	32
• Activation/deactivation of IO Devices	Yes
- Maximum number of IO devices that can be activated/deactivated at the same time.	8
• IO Devices changing during operation (partner ports), supported	Yes
• Device replacement without swap medium	Yes
• Send cycles	250 µs, 500 µs, 1 ms
• Updating time	0.25...512 depending on the send cycle
• Services	
- PG/OP communication	Yes
- S7 communication	Yes
- Isochronous mode	Yes
- Open IE communication	Yes
• Address area	
- Inputs, max.	16 kbyte
- Outputs, max.	16 kbyte
- User data per address area, max.	2 kbyte
- User data consistency, max.	256 byte
Open IE communication	
• Open IE communication, supported	Yes
• Number of connections, max.	32
• Local port numbers used at the system end	0, 20, 21, 25, 80, 102, 135, 161, 34962, 34963, 34964, 65532, 65533, 65534, 65535

6ES7 671-0RC08-0YA0 SIMATIC WinAC RTX 2010	
Isochronous mode	
Isochronous operation (application synchronized up to terminal)	Yes
Number of DP masters with isochronous mode	2
User data per isochronous slave, max.	128 byte
equidistance	Yes
shortest clock pulse	2.2 ms; 2.2 ms without partial process image; 2.2 ms with partial process image
Communication functions	
PG/OP communication	Yes
Data record routing	Yes; Only with CP 5611 or integrated PROFIBUS interface of the SIMATIC PC
Global data communication	
• supported	No
S7 basic communication	
• supported	No
S7 communication	
• supported	Yes
• as server	Yes
• as client	Yes
• User data per job, max.	64 kbyte; When using BSEND/USEND
Open IE communication	
• TCP/IP	Yes
- Number of connections, max.	32
- Data length for connection type 01H, max.	Not supported
- Data length for connection type 11H, max.	65 534 byte
- Data length, max.	65 534 byte
• ISO-on-TCP (RFC1006)	Yes
- Number of connections, max.	32
- Data length, max.	65 534 byte
• UDP	Yes
- Number of connections, max.	32
- Data length, max.	1 472 byte
Web server	
• supported	Yes
• Number of HTTP clients	2
• User-defined websites	No

SIMATIC PC-based controllers

SIMATIC PC-based controllers

SIMATIC WinAC RTX

Technical specifications (continued)

6ES7 671-0RC08-0YA0 SIMATIC WinAC RTX 2010	
PROFINET CBA (at set setpoint communication load)	
• Setpoint for the CPU communication load	20 %
• Number of remote interconnection partners	64
• Number of functions, master/slave	30
• Total of all Master/Slave connections	1 000
• Data length of all incoming connections master/slave, max.	6 800 byte
• Data length of all outgoing connections master/slave, max.	6 800 byte
• Number of device-internal and PROFIBUS interconnections	500
• Data length of device-internal und PROFIBUS interconnections, max.	4 000 byte
• Data length per connection, max.	1 400 byte
• Remote interconnections with acyclic transmission	
- Sampling frequency: Sampling time, min.	500 ms
- Number of incoming interconnections	100
- Number of outgoing interconnections	100
- Data length of all incoming interconnections, max.	2 000 byte
- Data length of all outgoing interconnections, max.	2 000 byte
- Data length per connection, max.	1 400 byte
• Remote interconnections with cyclic transmission	
- Transmission frequency: Transmission interval, min.	10 ms
- Number of incoming interconnections	200
- Number of outgoing interconnections	200
- Data length of all incoming interconnections, max.	4 800 byte
- Data length of all outgoing interconnections, max.	4 800 byte
- Data length per connection, max.	250 byte
• HMI variables via PROFINET (acyclic)	
- Number of stations that can log on for HMI variables (PN OPC/iMap)	3
- HMI variable updating	500 ms
- Number of HMI variables	200
- Data length of all HMI variables, max.	2 000 byte
• PROFIBUS proxy functionality	
- supported	Yes
- Number of linked PROFIBUS devices	16
- Data length per connection, max.	240 byte; Slave-dependent
Number of connections	
• overall	96

6ES7 671-0RC08-0YA0 SIMATIC WinAC RTX 2010	
S7 message functions	
Number of login stations for message functions, max.	62
SCAN procedure	No
Process diagnostic messages	Yes; ALARM_S, ALARM_SQ, ALARM_D, ALARM_DQ
simultaneously active Alarm-S blocks, max.	20; of a total of 20 for all SFCs
Alarm 8-blocks	Yes
• Number of instances for alarm 8 and S7 communication blocks, max.	4 000
Process control messages	No
Test commissioning functions	
Status block	Yes
Single step	Yes
Number of breakpoints	20
Status/control	
• Status/control variable	Yes
Forcing	
• Forcing	No
Diagnostic buffer	
• present	Yes
• Number of entries, max.	3 200
- adjustable	Yes
- preset	120
Hardware requirements	
Hardware required	PC with color monitor, keyboard, mouse or pointing device for Windows
Required memory on hard disk, min.	100 Mbyte
Main memory, min.	1 Gbyte; WES7: 2 GB
Processor	Intel Celeron M, 900 MHz or compatible
• Multi-processor system	Yes; Dual Pentium, CoreDuo, Core2Duo or compatible
• Hyper-threading	Yes
Operating systems	
Windows NT 4.0	No
Windows 2000	No
Windows XP	Yes; Professional, SP2 and SP3
Windows XP embedded	Yes; With the delivery image of the SIMATIC PC
• Supported HAL types under Windows XP	ACPI uniprocessor PC, ACPI multiprocessor PC, MPS multiprocessor PC
Windows Vista	No
Windows 7	Yes; Professional, Enterprise, Ultimate (only 32 bits)
Windows embedded Standard 7	Yes

Technical specifications (continued)

6ES7 671-0RC08-0YA0 SIMATIC WinAC RTX 2010		6ES7 671-0RC08-0YA0 SIMATIC WinAC RTX 2010	
Configuration			
programming		Know-how protection	
• Nesting levels	8	• User program protection/password protection	Yes
• Programming language		Open Development interfaces	
- LAD	Yes	• CCX (Custom Code Extension)	Yes; WinAC ODK V4.2 or higher
- FBD	Yes	• CMI (Controller Management Interface)	Yes; WinAC ODK V4.2 or higher
- STL	Yes	• SMX (Shared Memory Extension)	Yes; WinAC ODK V4.2 or higher
- SCL	Yes	- Inputs	4 kbyte
- CFC	Yes	- Outputs	4 kbyte
- GRAPH	Yes		
- HiGraph®	Yes	Weight	
• Software libraries		Weight, approx.	100 g; With packaging
- Easy Motion Control	Yes		

Ordering data

	Order No.		Order No.
SIMATIC WinAC RTX 2010	6ES7 671-0RC08-0YA0	CP 5623 communications processor	6GK1562-3AA00
Software PLC for PC-based automation tasks with stringent deterministic requirements; PROFIBUS and PROFINET; CD-ROM with electronic documentation d, e, f; single license, executable under Windows XP SP2 and SP3 as well as Windows 7 (32 bit)		PCI Express x1 card (32 bit) for connection to PROFIBUS incl. DP-Base software with NCM PC; DP-RAM interface for DP master or DP slave, incl. PG and FDL protocols; single license for 1 installation, runtime software, software and electronic manual on CD-ROM, Class A, for operating system support see SIMATIC NET software; German/English	
SIMATIC WinAC RTX 2010 Upgrade	6ES7 671-0RC08-0YE0	CP 1616 communications processor	6GK1 161-6AA02
For upgrading from basic/RTX V3.x, V4.0, V4.1 2005, 2008 and 2009; single license, executable under Windows XP SP2 and SP3 and Windows 7 (32 bit)		PCI Card (32 bit; 3.3/5 V universal key) with ASIC ERTEC 400 for connecting PCs to PROFINET IO with 4-port real-time switch (RJ45); incl. IO-Base software for PROFINET IO controller (RT operation) and NCM PC; single license for one installation, runtime software, software and electronic manual on CD-ROM, Class A, for 32 bit Windows XP Professional; German/English	
CP 5611 A2 communications processor	6GK1 561-1AA01	CP 1604 Microbox Package	6GK1 160-4AU00
PCI card (32 bit) for connection of a programming device or PC to PROFIBUS		Package for implementing the CP 1604 in the SIMATIC Microbox PC; comprising the CP 1604, connection board, power supply and expansion rack for Microbox PC; for use with Development Kit DK-16xx PN IO; NCM PC	
CP 5621 communications processor	6GK1 562-1AA00		
• PCI Express x1 card (32 bit) for connection of a programming device or PC to PROFIBUS			
• PCI Express x1 card (32 bit) CP 5621 and MPI cable, 5 m	6GK1 562-1AM00		
CP 5603 Microbox Package	6GK1 560-3AU00		
Comprising CP 5603 module and Microbox expansion rack			
CP 5613 A2 communications processor	6GK1 561-3AA01		
PCI card (32 bit; 3.3 V/5 V) for connection to PROFIBUS incl. DP-Base software with NCM PC; DP-RAM interface for DP master, incl. PG and FDL protocol; single license for 1 installation, runtime software, software and electronic manual on CD-ROM, Class A, for 32 bit Windows 2000 Professional/Server, Windows XP Professional, German/English			

SIMATIC PC-based controllers

SIMATIC PC-based controllers

SIMATIC WinAC RTX F

Overview



- SIMATIC WinAC RTX F:
Optimized for applications that demand a high degree of flexibility and integration capability and that must also satisfy safety requirements up to SIL 3 (IEC 61508).
- The software solution for tasks that require hard deterministic behavior and high performance.
- With real-time expansion for assuring deterministic behavior for the control section.
- Distributed I/O can be connected over PROFIBUS and/or PROFINET, also safety-related over PROFIsafe.

Technical specifications

6ES7 671-1RC08-0YA0 SIMATIC WinAC RTX F 2010	
General information	
Hardware product version	-
Firmware version	V4.6
Engineering with	
• Programming package	STEP 7 V5.5 or higher + hardware update / iMap V3.0 SP1 / option package S7 Distributed Safety V5.4 + SP5 / S7 F Configuration Pack V5.5 + SP6 + HF1
Memory	
Work memory	
• integrated (for program)	4 Mbyte; Adjustable; depends on Non Paged Memory Pool
• integrated (for data)	4 Mbyte; Adjustable; depends on Non Paged Memory Pool
Load memory	
• integrated RAM, max.	Adjustable; depends on Non Paged Memory Pool
CPU processing times	
for bit operations, typ.	0.004 µs; typ.
for fixed point arithmetic, typ.	0.003 µs; typ.
for floating point arithmetic, typ.	0.004 µs; typ.
Reference platform	Pentium IV, 2.4 GHz
CPU-blocks	
DB	
• Number, max.	65 535; Limited only by RAM set for data
• Size, max.	64 kbyte
FB	
• Number, max.	65 536; Limited only by RAM set for code
• Size, max.	64 kbyte
FC	
• Number, max.	65 536; Limited only by RAM set for code
• Size, max.	64 kbyte
OB	
• Size, max.	64 kbyte
Nesting depth	
• per priority class	24
• additional within an error OB	24

6ES7 671-1RC08-0YA0 SIMATIC WinAC RTX F 2010	
Counters, timers and their retentivity	
S7 counter	
• Number	2 048
• Retentivity	
- adjustable	Yes
- lower limit	0
- upper limit	2 047
- preset	8
• Counting range	
- adjustable	Yes
- lower limit	0
- upper limit	999
IEC counter	
• present	Yes
• Type	SFB
• Number	Unlimited (limited only by RAM capacity)
S7 times	
• Number	2 048
• Retentivity	
- adjustable	Yes
- lower limit	0
- upper limit	2 047
- preset	0
• Time range	
- lower limit	10 ms
- upper limit	9 990 s
IEC timer	
• present	Yes
• Type	SFB
• Number	Unlimited (limited only by RAM capacity)

Technical specifications (continued)

6ES7 671-1RC08-0YA0 SIMATIC WinAC RTX F 2010	
Data areas and their retentivity	
Retentivity without UPS and PS Extension Board	128 kbyte with SIMATIC IPC427C and HMI IPC477C; further SIMATIC PCs on request
Retentivity with UPS	all data
Flag	
• Number, max.	16 kbyte
• Retentivity preset	MB 0 to MB 15
• Number of clock memories	8
Data blocks	
• Retentivity adjustable	Yes; via non-retain property on DB
• Retentivity preset	Yes
Local data	
• adjustable, max.	64 kbyte
• preset	32 kbyte
• per priority class, max.	61 440 byte
Address area	
I/O address area	
• Inputs	16 kbyte
• Outputs	16 kbyte
• of which, distributed	
- DP interface, inputs	16 kbyte
- DP interface, outputs	16 kbyte
- PN interface, inputs	16 kbyte
- PN interface, outputs	16 kbyte
Process image	
• Inputs, adjustable	8 kbyte
• Outputs, adjustable	8 kbyte
• Inputs, default	512 byte
• Outputs, default	512 byte
Subprocess images	
• Number of subprocess images, max.	15
Digital channels	
• Inputs	128 000
• Outputs	128 000
Analog channels	
• Inputs	8 000
• Outputs	8 000
Hardware configuration	
Submodules	
• Number of submodules, max	4
• of which PROFIBUS, max.	4; Supported interfaces: see 1st and 2nd interface
• of which Industrial Ethernet, max.	1; Supported interfaces: see 3rd and 4th interface
Number of operable FMs and CPs (recommended)	
• FM	4; FM distributed: FM 350-1, FM 350-2, FM 351, FM 352 / FM 352-5, FM 353, FM 354, FM 355, FM 355-2
• CP, point-to-point	2; CP 340, CP 341 distributed
• CP, LAN	Over PC CP

6ES7 671-1RC08-0YA0 SIMATIC WinAC RTX F 2010	
Time of day	
Clock	
• Hardware clock (real-time clock)	Yes
• battery-backed and synchronizable	Yes
Operating hours counter	
• Number	8
Clock synchronization	
• supported	Yes
• to PC-CP, slave	Yes
• on Ethernet via NTP	Yes
1st interface	
Type of interface	CP 5611-A2, CP 5621, integrated PB interface of the SIMATIC PC
Max. no. of simultaneously operable CPs	1
Physics	RS 485 / PROFIBUS
Isolated	Yes
Power supply to interface (15 to 30 V DC), max.	does not exist
Number of connection resources	8
Functionality	
• MPI	No
• DP master	Yes
• DP slave	No
DP master	
• Number of connections, max.	8
• Transmission rate, max.	12 Mbit/s
• Number of DP slaves, max.	64
• Services	
- PG/OP communication	Yes
- Global data communication	No
- S7 basic communication	No
- S7 communication	Yes
- S7 communication, as client	Yes
- S7 communication, as server	Yes
- Equidistance mode support	Yes; Only in conjunction with isochronous mode
- Isochronous mode	Yes
- SYNC/FREEZE	Yes
- Activation/deactivation of DP slaves	Yes
- Direct data exchange (slave-to-slave communication)	Yes
- DPV1	Yes
• Address area	
- Inputs, max.	16 kbyte
- Outputs, max.	16 kbyte
• User data per DP slave	
- Inputs, max.	244 byte
- Outputs, max.	244 byte

SIMATIC PC-based controllers

SIMATIC PC-based controllers

SIMATIC WinAC RTX F

Technical specifications (continued)

6ES7 671-1RC08-0YA0 SIMATIC WinAC RTX F 2010	
2nd interface	
Type of interface	CP 5613, CP 5613-A2, CP 5603, CP 5623
Max. no. of simultaneously operable CPs	4
Physics	RS 485 / PROFIBUS
Isolated	Yes
Functionality	
• MPI	No
• DP master	Yes
• DP slave	No
DP master	
• Number of connections, max.	50
• Transmission rate, max.	12 Mbit/s
• Number of DP slaves, max.	125
• Services	
- PG/OP communication	Yes
- Global data communication	No
- S7 basic communication	No
- S7 communication	Yes
- S7 communication, as client	Yes
- S7 communication, as server	Yes
- Equidistance mode support	Yes; Only in conjunction with isochronous mode
- Isochronous mode	Yes
- SYNC/FREEZE	Yes
- Activation/deactivation of DP slaves	Yes
- Direct data exchange (slave-to-slave communication)	Yes
- DPV1	Yes
• Address area	
- Inputs, max.	16 kbyte
- Outputs, max.	16 kbyte
• User data per DP slave	
- Inputs, max.	244 byte
- Outputs, max.	244 byte
3rd interface	
Type of interface	PROFINET
Max. no. of simultaneously operable CPs	1; Intel Pro/1000 (Intel 82571EB, 82573L, 82574L, 82541PI; non-shared IRQ required); integrated IE interface SIMATIC PC 4x7B, 6x7B, 8x7B, IPC4x7C, IPC6x7C, IPC8x7C
Physics	Ethernet
Isolated	Yes
Integrated switch	No
Number of ports	1
Automatic detection of transmission speed	Yes; 10/100 Mbit/s

6ES7 671-1RC08-0YA0 SIMATIC WinAC RTX F 2010	
Autonegotiation	Yes
Autocrossing	Yes
Media redundancy	
• supported	No
Functionality	
• PROFINET IO Controller	Yes
• PROFINET IO Device	No
• PROFINET CBA	Yes
PROFINET IO Controller	
• Transmission rate, min.	100 Mbit/s
• Transmission rate, max.	100 Mbit/s
• Number of connectable IO devices, max.	128
• Max. number of connectable IO devices for RT	128
- of which in line, max.	128
• IRT, supported	No
• Prioritized startup supported	Yes
- Number of IO Devices, max.	32
• Activation/deactivation of IO Devices	Yes
- Maximum number of IO devices that can be activated/deactivated at the same time.	8
• IO Devices changing during operation (partner ports), supported	Yes
• Device replacement without swap medium	Yes
• Send cycles	1 ms
• Updating time	1 - 512 ms (minimum value depends on communication share set for PROFINET I/O, on the number of I/O devices, and on the volume of configured user data)
• Services	
- PG/OP communication	Yes
- S7 communication	Yes
- Isochronous mode	No
- Open IE communication	Yes
• Address area	
- Inputs, max.	16 kbyte
- Outputs, max.	16 kbyte
- User data per address area, max.	2 kbyte
- User data consistency, max.	256 byte
Open IE communication	
• Open IE communication, supported	Yes
• Number of connections, max.	32
• Local port numbers used at the system end	0, 20, 21, 23, 25, 80, 102, 135, 161, 8080, 34962, 34963, 34964, 65532, 65533, 65534, 65535
• Keep-alive function, supported	Yes

Technical specifications (continued)

6ES7 671-1RC08-0YA0 SIMATIC WinAC RTX F 2010	
4th interface	
Type of interface	PROFINET
Max. no. of simultaneously operable CPs	1; CP 1616 (HW release 8 or above), CP 1604 (HW release 7 or higher), integrated PN interface of SIMATIC PC and S7-mEC
Physics	Ethernet
Isolated	Yes
Integrated switch	Yes
Number of ports	3
Automatic detection of transmission speed	Yes; 10/100 Mbit/s
Autonegotiation	Yes
Autocrossing	Yes
Change of IP address at runtime, supported	Yes
Number of connection resources	32
Media redundancy	
• supported	Yes
• Switchover time on line break, typically	200 ms
• Number of stations in the ring, max.	50
Functionality	
• PROFINET IO Controller	Yes
• PROFINET IO Device	No
• PROFINET CBA	Yes
PROFINET IO Controller	
• Transmission rate, max.	100 Mbit/s
• Max. number of connectable IO Devices for RT	256
- of which in line, max.	256
• Number of IO devices with IRT and the option "high flexibility"	64
- of which in line, max.	32
• Number of IO Devices with IRT and the option "high performance", max.	64
- of which in line, max.	64
• IRT, supported	Yes
• Prioritized startup supported	Yes
- Number of IO Devices, max.	32
• Activation/deactivation of IO Devices	Yes
- Maximum number of IO devices that can be activated/deactivated at the same time.	8
• IO Devices changing during operation (partner ports), supported	Yes
• Device replacement without swap medium	Yes
• Send cycles	250 µs, 500 µs, 1 ms
• Updating time	0.25...512 depending on the send cycle
• Services	
- PG/OP communication	Yes
- S7 communication	Yes
- Isochronous mode	Yes
- Open IE communication	Yes
• Address area	
- Inputs, max.	16 kbyte
- Outputs, max.	16 kbyte
- User data per address area, max.	2 kbyte
- User data consistency, max.	256 byte

6ES7 671-1RC08-0YA0 SIMATIC WinAC RTX F 2010	
Open IE communication	
• Open IE communication, supported	Yes
• Number of connections, max.	32
• Local port numbers used at the system end	0, 20, 21, 25, 80, 102, 135, 161, 34962, 34963, 34964, 65532, 65533, 65534, 65535
Isochronous mode	
Isochronous operation (application synchronized up to terminal)	Yes
Number of DP masters with isochronous mode	2
User data per isochronous slave, max.	128 byte
equidistance	Yes
shortest clock pulse	2.2 ms; 2.2 ms without partial process image; 2.2 ms with partial process image
Communication functions	
PG/OP communication	Yes
Data record routing	Yes; Only with CP 5611 or integrated PROFIBUS interface of the SIMATIC PC
Global data communication	
• supported	No
S7 basic communication	
• supported	No
S7 communication	
• supported	Yes
• as server	Yes
• as client	Yes
• User data per job, max.	64 kbyte; Depends on which block is used: BSEND/USEND or PUT/GET
Open IE communication	
• TCP/IP	Yes
- Number of connections, max.	32
- Data length for connection type 01H, max.	Not supported
- Data length for connection type 11H, max.	65 534 byte
- Data length, max.	65 534 byte
• ISO-on-TCP (RFC1006)	Yes
- Number of connections, max.	32
- Data length, max.	65 534 byte
• UDP	Yes
- Number of connections, max.	32
- Data length, max.	1 472 byte
Web server	
• supported	Yes
• Number of HTTP clients	2
• User-defined websites	No

SIMATIC PC-based controllers

SIMATIC PC-based controllers

SIMATIC WinAC RTX F

Technical specifications (continued)

6ES7 671-1RC08-0YA0 SIMATIC WinAC RTX F 2010	
PROFINET CBA (at set setpoint communication load)	
• Setpoint for the CPU communication load	20 %
• Number of remote interconnection partners	64
• Number of functions, master/slave	30
• Total of all Master/Slave connections	1 000
• Data length of all incoming connections master/slave, max.	6 800 byte
• Data length of all outgoing connections master/slave, max.	6 800 byte
• Number of device-internal and PROFIBUS interconnections	500
• Data length of device-internal und PROFIBUS interconnections, max.	4 000 byte
• Data length per connection, max.	1 400 byte
• Remote interconnections with acyclic transmission	
- Sampling frequency: Sampling time, min.	500 ms
- Number of incoming interconnections	100
- Number of outgoing interconnections	100
- Data length of all incoming interconnections, max.	2 000 byte
- Data length of all outgoing interconnections, max.	2 000 byte
- Data length per connection, max.	1 400 byte
• Remote interconnections with cyclic transmission	
- Transmission frequency: Transmission interval, min.	10 ms
- Number of incoming interconnections	200
- Number of outgoing interconnections	200
- Data length of all incoming interconnections, max.	4 800 byte
- Data length of all outgoing interconnections, max.	4 800 byte
- Data length per connection, max.	250 byte
• HMI variables via PROFINET (acyclic)	
- Number of stations that can log on for HMI variables (PN OPC/IMap)	3
- HMI variable updating	500 ms
- Number of HMI variables	200
- Data length of all HMI variables, max.	2 000 byte
• PROFIBUS proxy functionality	
- supported	Yes
- Number of linked PROFIBUS devices	16
- Data length per connection, max.	240 byte; Slave-dependent
Number of connections	
• overall	96

6ES7 671-1RC08-0YA0 SIMATIC WinAC RTX F 2010	
S7 message functions	
Number of login stations for message functions, max.	62
SCAN procedure	No
Process diagnostic messages	Yes; ALARM_S, ALARM_SQ, ALARM_D, ALARM_DQ
simultaneously active Alarm-S blocks, max.	20; of a total of 20 for all SFCs
Alarm 8-blocks	Yes
• Number of instances for alarm 8 and S7 communication blocks, max.	4 000
Process control messages	No
Test commissioning functions	
Status block	Yes
Single step	Yes
Number of breakpoints	20
Status/control	
• Status/control variable	Yes
Forcing	
• Forcing	No
Diagnostic buffer	
• present	Yes
• Number of entries, max.	3 200
- adjustable	Yes
- preset	120
Hardware requirements	
Hardware required	PC with color monitor, keyboard, mouse or pointing device for Windows
Required memory on hard disk, min.	100 Mbyte
Main memory, min.	1 Gbyte
Processor	Intel Celeron M 900 MHz or compatible (older PC systems with Programmable Interrupt Controllers (PIC) are not suitable for WinAC RTX F 2010.)
• Multi-processor system	No
• Hyper-threading	Yes
Operating systems	
Windows NT 4.0	No
Windows 2000	No
Windows XP	Yes; Professional, SP2 and SP3
Windows XP embedded	Yes; With the delivery image of the SIMATIC PC
• Supported HAL types under Windows XP	ACPI uniprocessor PC, ACPI multiprocessor PC, MPS multiprocessor PC
Windows Vista	No
Windows 7	Yes; Professional, Enterprise, Ultimate (only 32 bits)
Windows embedded Standard 7	No

Technical specifications (continued)

	6ES7 671-1RC08-0YA0 SIMATIC WinAC RTX F 2010	6ES7 671-1RC08-0YA0 SIMATIC WinAC RTX F 2010
Configuration		
programming		Know-how protection
• Nesting levels	8	• User program protection/password protection
• Programming language		• Block encryption
- LAD	Yes	Open Development interfaces
- FBD	Yes	• CCX (Custom Code Extension)
- STL	Yes	• CMI (Controller Management Interface)
- SCL	Yes	• SMX (Shared Memory Extension)
- CFC	Yes	- Inputs
- GRAPH	Yes	- Outputs
- HiGraph®	Yes	Weight
• Software libraries		Weight, approx.
- Easy Motion Control	Yes	100 g; With packaging

Ordering data

	Order No.		Order No.
SIMATIC WinAC RTX F 2010	6ES7 671-1RC08-0YA0	CP 5623 communications processor	6GK1 562-3AA00
SIMATIC WinAC RTX F 2010 upgrade	6ES7 671-1RC08-0YE0	PCI Express x1 card (32 bit) for connection to PROFIBUS incl. DP-Base software with NCM PC; DP-RAM interface for DP master or DP slave, incl. PG and FDL protocols; single license for 1 installation, runtime software, software and electronic manual on CD-ROM, Class A, for operating system support see SIMATIC NET software; German/English	
CP 5611 A2 communications processor	6GK1 561-1AA01	CP 1616 communications processor	6GK1 161-6AA02
PCI card (32 bit) for connection of a programming device or PC to PROFIBUS		PCI Card (32 bit; 3.3/5 V universal key) with ASIC ERTEC 400 for connecting PCs to PROFINET IO with 4-port real-time switch (RJ45); incl. IO-Base software for PROFINET IO controller (RT operation) and NCM PC; single license for one installation, runtime software, software and electronic manual on CD-ROM, Class A, for 32 bit Windows XP Professional; German/English	
CP 5621 communications processor	6GK1 562-1AA00	CP 1604 Microbox Package	6GK1 160-4AU00
PCI Express x1 card (32 bit) for connection of a programming device or PC to PROFIBUS		Package for implementing the CP 1604 in the SIMATIC Microbox PC; comprising the CP 1604, connection board, power supply and expansion rack for Microbox PC; for use with Development Kit DK-16xx PN IO; NCM PC	
PCI Express x1 card (32 bit) CP 5621 and MPI cable, 5 m	6GK1 562-1AM00		
CP 5603 Microbox Package	6GK1 560-3AU00		
Comprising CP 5603 module and Microbox expansion rack			
CP 5613 A2 communications processor	6GK1 561-3AA01		
PCI card (32 bit; 3.3 V/5 V) for connection to PROFIBUS incl. DP-Base software with NCM PC; DP-RAM interface for DP master, incl. PG and FDL protocol; single license for 1 installation, runtime software, software and electronic manual on CD-ROM, Class A, for 32 bit Windows 2000 Professional/Server, Windows XP Professional, German/English			

SIMATIC PC-based controllers

SIMATIC PC-based controllers

SIMATIC WinAC ODK

Overview



- SIMATIC WinAC software PLCs support powerful interfaces which permit close meshing of the control task with PC-based applications.
- WinAC ODK allows the user to develop applications or to integrate already existing applications into the control task.

New with WinAC ODK V4.2:

- CCX interface:
 - New SFB 65003 for asynchronous execution of ODK applications
 - Expansion of data access functions
 - Creation of Windows DLL with C# and VB
- SMX interface:
 - Access to the Shared Memory interface under IntervalZero RTX
 - Expansion of data access functions
 - Creation of Windows applications with C# and VB
- Supports MS Visual Studio 2005 and 2008 (under Windows)

Technical specifications

6ES7 806-1CC03-0BA0 SIMATIC WinAC ODK V4.2	
Hardware requirements	
Hardware required	PC with color monitor, keyboard, mouse or pointing device for Windows
Required memory on hard disk, min.	30 Mbyte
Main memory, min.	512 Mbyte
Processor	Intel Pentium 800 MHz
Operating systems	
Windows XP	Yes; Professional, SP2 and SP3
Configuration	
Open Development interfaces	
• CCX (Custom Code Extension)	Yes; WinAC RTX 2008 (V4.4) or higher; programming languages: Microsoft Visual C++ V6.0 SP5 or higher, .net 2003, 2005, 2008; Microsoft Visual Basic 2005, 2008; Microsoft Visual C# 2005, 2008
• CMI (Controller Management Interface)	Yes; WinAC RTX 2005 SP2 (V4.3) or higher; programming languages: Microsoft Visual C++ V6.0 SP5 or higher, .net 2003, 2005, 2008; Microsoft Visual Basic V6.0 SP5 or higher, .net 2003, 2005, 2008; Microsoft Visual C# .net 2003, 2005, 2008
• SMX (Shared Memory Extension)	Yes; WinAC RTX 2008 (V4.4) or higher; programming languages: Microsoft Visual C++ V6.0 SP5 or higher, .net 2003, 2005, 2008; Microsoft Visual Basic 2005, 2008; Microsoft Visual C# 2005, 2008
Weight	
Weight, approx.	200 g

Ordering data

SIMATIC WinAC ODK V4.2
for integration of C/C++ code in WinAC PLCs, executable under Windows XP SP2 or SP3; CD-ROM with electronic documentation
Single license

Order No.

6ES7 806-1CC03-0BA0

SIMATIC ET 200 distributed I/O



9/4	Introduction	9/69	<u>I/O modules</u>
9/5	ET 200SP	9/69	Power modules for PM-E electronic modules
9/5	<u>Introduction</u>	9/71	SIPLUS power modules for PM-E electronic modules
9/6	<u>Interface modules without CPU</u>	9/73	Reserve modules
9/6	IM 155-6PN Standard	9/74	Potential isolation module
9/8	<u>SIPLUS interface modules</u>	9/75	Digital electronic modules
9/9	<u>I/O modules</u>	9/88	SIPLUS digital electronic modules
9/9	Digital input modules	9/90	Analog electronic modules
9/11	Digital output modules	9/106	SIPLUS analog electronic modules
9/14	SIPLUS digital input modules	9/108	<u>Technology modules</u>
9/16	SIPLUS digital output modules	9/108	SSI module
9/18	Analog input modules	9/110	2 PULSE pulse generator
9/22	Analog output modules	9/112	1STEP stepper module
9/24	SIPLUS analog input modules	9/113	1 POS U positioning module
9/26	SIPLUS analog output modules	9/115	1 COUNT 24 V/100 kHz counter module
9/28	<u>Communication</u>	9/117	SIPLUS 1 COUNT 24V/100kHz counter module
9/28	CM PtP serial interface	9/118	1 COUNT 5 V/500 kHz counter module
9/30	CM IO-Link	9/121	1SI interface module
9/32	<u>BaseUnits</u>	9/123	SIPLUS 1 SI interface module
9/34	<u>SIPLUS BaseUnits</u>	9/124	SIWAREX CS
9/37	<u>Bus adapters</u>	9/126	SIWAREX CF
9/38	<u>Accessories</u>	9/128	<u>I/O modules</u>
9/39	ET 200S	9/128	Terminal modules for power modules and electronic modules
9/39	<u>Introduction</u>	9/130	SIPLUS terminal modules for power and electronic modules
9/41	<u>Interface modules with CPU</u>	9/133	<u>Fail-safe I/O modules</u>
9/41	IM 151-7 CPU	9/133	Overview
9/44	IM 151-8 PN/DP CPU	9/134	PM-E F PROFIsafe F power module
9/47	Master interface module for IM 151 CPU	9/137	F electronic modules
9/48	<u>SIPLUS interface modules with CPU</u>	9/140	F electronic module relays
9/48	SIPLUS IM151-7 CPU	9/142	F terminal modules
9/49	SIPLUS IM151-8 PN/DP CPU	9/144	SIPLUS F electronic modules
9/50	SIPLUS master interface modules for IM 151 CPU	9/145	<u>IO-Link master modules</u>
9/51	<u>Interface module with fail-safe CPU</u>	9/145	4SI IO-Link electronic module
9/51	IM 151-7 F-CPU	9/146	4SI SIRIUS electronic module
9/53	IM 151-8 F PN/DP CPU	9/147	<u>Motor starters and safety motor starters</u>
9/56	<u>SIPLUS interface modules with fail-safe CPU</u>	9/147	General data
9/56	SIPLUS IM 151-7 F-CPU	9/153	Standard motor starters
9/57	SIPLUS IM 151-8 F PN/DP CPU	9/154	Standard terminal modules
9/58	<u>Interface modules without CPU</u>	9/156	High Feature motor starters
9/58	IM 151-1	9/158	High Feature terminal modules
9/64	IM 151-3 PN	9/159	Power modules
9/67	<u>SIPLUS interface modules without CPU</u>	9/160	Terminal module for power module
9/67	SIPLUS IM 151-1	9/161	ET 200S fail-safe motor starter
9/68	SIPLUS IM 151-3PN	9/163	Fail-safe terminal modules
		9/164	Safety local and PROFIsafe modules
		9/173	Terminal modules for safety local and PROFIsafe modules
		9/175	Accessories
		9/180	<u>Software</u>
		9/180	Motor Starter ES

SIMATIC ET 200 distributed I/O



9/184	<u>Add-on products for the ET 200S</u>
9/184	EtherNet/IP interface module
9/185	DeviceNet interface module

9/186	ET 200MP
9/186	<u>Introduction</u>
9/187	<u>Interface modules</u>
9/187	IM 155-5 PN
9/189	SIPLUS IM 155-5 PN
9/190	<u>I/O modules</u>

9/191	ET 200M
9/191	<u>Introduction</u>
9/192	<u>Interface modules</u>
9/192	IM 153-1/153-2
9/195	IM 153-4 PN
9/197	<u>SIPLUS interface modules</u>
9/197	SIPLUS IM 153-1/153-2
9/199	SIPLUS IM 153-4 PN IO
9/200	<u>I/O modules</u>
9/200	Digital/analog modules
9/201	Analog input module with HART
9/203	Analog output module with HART
9/205	Ex-analog input module with HART
9/207	Ex-analog output module with HART
9/209	SIPLUS analog input module with HART
9/210	SIPLUS analog output module with HART
9/211	SIPLUS Ex analog input module with HART
9/212	<u>Function modules</u>
9/214	<u>Special modules</u>
9/214	<u>Communication</u>
9/215	ASM 475
9/217	<u>Power supplies</u>

9/218	ET 200iSP
9/218	Introduction
9/220	IM 152-1 interface module
9/222	Power supply units
9/224	Digital electronic modules
9/230	Analog electronic modules
9/235	F digital input module
9/238	F digital output module
9/241	F analog input module
9/244	ET 200iSP watchdog module
9/245	Reserve module
9/247	Terminal modules
9/248	RS 485-IS coupler
9/250	Stainless steel wall enclosure

9/253	ET 200pro
9/253	<u>Introduction</u>
9/254	<u>Interface modules</u>
9/254	IM 154-1 and IM 154-2
9/258	IM 154-4 PN
9/261	IM 154-6 PN IWLAN
9/264	IM 154-8 PN/DP CPU
9/268	IM 154-8 F PN/DP CPU
9/273	<u>I/O modules</u>
9/273	Digital expansion modules
9/279	Analog expansion modules
9/286	Fail-safe digital expansion modules
9/287	PM-E power module
9/289	PM-O power module output
9/290	ET 200pro pneumatic interface
9/292	SIMATIC RF170C
9/294	<u>SIMATIC ET200pro PS</u>
9/296	<u>Motorstarter ET 200pro</u>
9/296	General data
9/299	Standard motor starters
9/300	High Feature motor starters
9/301	ET 200pro isolator module
9/302	ET 200pro Safety motor starter Solutions local/PROFIsafe – Safety local modules
9/305	ET 200pro Safety motor starter Solutions local/PROFIsafe – Safety PROFIsafe modules
9/306	Accessories for ET 200pro motor starters
9/311	<u>Software</u>
9/311	Motor Starter ES

9/312 ET 200eco PN

9/324 IO-Link master ET 200eco PN

9/327 ET 200eco

**9/335 PROFIBUS components**

- 9/335 Power Rail Booster
- 9/336 Diagnostic repeater for PROFIBUS DP
- 9/338 PROFIBUS DP ASICs
- 9/340 Connections/interfaces

9/341 SIPLUS PROFIBUS components for ET 200

- 9/341 SIPLUS diagnostic repeater for PROFIBUS

9/342 PROFINET components

- 9/342 Enhanced Real-Time Ethernet Controller ERTEC
- 9/345 Development kit

9/346 Network components for PROFIBUS

- 9/346 Repeater RS 485 for PROFIBUS
- 9/347 Active RS 485 terminating element

9/348 SIPLUS network components for PROFIBUS

- 9/348 SIPLUS RS 485 repeater
- 9/349 SIPLUS DP active RS485 terminating element

9/350 Network transitions

- 9/350 PN/PN coupler
- 9/351 DP/DP coupler

Brochures

For brochures serving as selection guides for SIMATIC products refer to:

www.siemens.com/simatic/printmaterial

SIMATIC ET 200 distributed I/O

Introduction

SIMATIC ET 200 Distributed IO

Overview



SIMATIC ET 200 offers the right solution for every application

With SIMATIC ET 200 a wide range of distributed I/O systems is available - for solutions in the control cabinet or without a control cabinet directly at the machine, as well as for applications in hazardous areas. The modular design makes it possible to scale and expand the ET 200 systems simply and in small stages. Already integrated add-on modules reduce costs, and at the same time offer a widely diverse range of possible applications. You can choose from many different combination options: Digital and analog inputs/outputs, intelligent modules with CPU functionality, safety systems, motor starters, pneumatic devices, frequency converters, as well as various different technology modules (e.g. for counting, positioning).

Communication over PROFIBUS and PROFINET, uniform engineering, transparent diagnostic possibilities as well as optimal interfacing to SIMATIC Controllers and HMI units prove the unique integration of Totally Integrated Automation.

PROFIBUS

PROFIBUS is the international standard (IEC 61158/61784) for the field level. It is the only fieldbus to allow communication both in manufacturing applications and in process-oriented applications.

PROFIBUS is used to connect field devices, e.g. distributed I/O devices or drives, to automation systems such as SIMATIC S7, SIMOTION, SINUMERIK, or PCs.

PROFIBUS is standardized in accordance with IEC 61158 and is a powerful, open and rugged fieldbus system with short response times. PROFIBUS is available in different forms for various applications.

PROFIBUS DP (distributed I/O)

PROFIBUS DP is used for connecting distributed field devices, e.g. SIMATIC ET 200, or drives with extremely fast response times. PROFIBUS DP is used when sensors/actuators are distributed at the machine or in the plant (e.g. field level).

PROFINET

PROFINET is the open, cross-vendor Industrial Ethernet standard (IEC 61158/61784) for automation.

Based on Industrial Ethernet, PROFINET enables direct communication between field devices (IO Devices) and controllers (IO Controllers), up to and including the solution of isochronous drive controls for motion control applications.

As PROFINET is based on Standard Ethernet according to IEEE 802.3, any devices from the field level to the management level can be connected.

In this way, PROFINET enables system-wide communication, supports plant-wide engineering and applies IT standards, such as Web server or FTP, right down to field level. Tried and tested fieldbus systems, such as PROFIBUS or AS-Interface, can be easily integrated without any modification to the existing devices.

AS-Interface

AS-Interface, the international standard (IEC 62026/EN 50295) which, as an alternative to the cable harness, links especially cost-effective sensors and actuators by means of a two-wire line. This two-wire line is also used to supply the individual stations with power. Thus the AS-Interface is the ideal partner for the PROFIBUS DP fieldbus.

SIMATIC ET 200 Configurator

Just a mouse click away from a tailor-made I/O station: With the SIMATIC ET 200 Configurator

First class support is even provided for configuring the ET 200 station with the ET 200 Configurator. The software tool guides the user through the configuring process and automatically creates order lists complete with accessories. It also assists with compliance with limits such as load currents, slot rules and parameters.

The configuration created in the ET 200 Configurator can be imported into STEP 7 without any problems. This reduces the engineering costs and saves double inputs.

The software tool is structured in a clear, intuitive manner: Six configuring layers make the work easy and convenient.

- General notes: General station data as well as a graphical presentation of the configured station
- Module selection: Guided selection of modules, through module suggestions
- Limits: Station size, weight, number of modules, load voltage, parameters, etc. are all displayed
- Accessories: Guided selection of the necessary accessories (module-specific or station-wide)
- Potential distribution: Graphical presentation of the potentials within a station
- Parts list: Automatic generation of a clearly understandable parts list simplifies the ordering process

The ET 200 configurator is a component of the SIMATIC Selection Tool, which is available as a configurator in the Industry Mall.

For brochures serving as selection guides for SIMATIC products refer to:

<http://www.siemens.com/printmaterial>

Overview



SIMATIC ET 200SP

The SIMATIC ET 200SP distributed I/O system is a scalable and extremely flexible distributed I/O system for interfacing the process signals to a central control system via PROFINET.

SIMATIC ET 200SP is mounted onto a rail and basically consists of:

- An interface module which communicates with all controllers that operate in conformance with the PROFINET standard IEC 61158
- Depending on the interface module, as many as 64 I/O modules that are inserted into passive BaseUnits in any combination
- A server module which completes the setup of the SIMATIC ET 200SP.

The distributed I/O system is particularly easy to use and, with its compact design, ensures maximum economy in the control cabinet. SIMATIC ET 200SP communicates over PROFINET. Its high speed and data transfer rate result in a significantly higher performance than conventional systems.

- Scalable I/O system with IP20 degree of protection for PROFINET
- Compact dimensions
- High degree of user-friendliness due to:
 - Push-in terminals for quick, one-handed wiring without the use of tools
 - Excellent accessibility of terminals due to arrangement in columns
 - Latching measurement taps for simple multi-point measurement
 - Clearly understandable labeling and color concept for fail-safe operation.
- Can be a combination of digital and analog input or output modules, other modules available soon
- Extensive system functions
 - Individual load group formation as system feature (power modules dispensed with)
 - Modules can be replaced during operation (hot swapping)
 - Start-up with gaps for partial commissioning
 - Permanent wiring with multi-conductor connection
 - System support of PROFIenergy for energy saving purposes
 - Electronic rating plate (I&M data 0...3)
 - All interface and I/O modules support firmware update
 - Configuration control via user software for option handling
- Simple retrofitting of modules without reconfiguration at the station end

SIMATIC ET 200 distributed I/O

ET 200SP

Interface modules without CPU

IM 155-6PN Standard

Overview



- Interface module for linking the ET 200SP to PROFINET
- Handles all data exchange with the PROFINET I/O Controller
- Bus Adapter (BA) for individual PROFINET connection
- Integrated 2-port switch for line configuration
- Max. 32 I/O modules
- Operation with gaps (non-equipped BaseUnits) possible
- Replacement of an I/O module possible during operation (single hot-swap)
- Load group formation without power module

Technical specifications

6ES7 155-6AA00-0BN0 IM 155-6 PN ST with BA 2xRJ45 and server module	
General information	
Product function	
• I&M data	Yes
Engineering with	
• STEP 7 TIA Portal can be configured/integrated as of version	as of V11.0 SP2 with HSP0024 / -
• STEP 7 can be configured/integrated as of version	V5.5 SP2 or higher with a GSD file / -
Supply voltage	
Rated voltage/DC	24 V
Reverse polarity protection	Yes
Mains buffering	
• Mains/voltage failure stored energy time	5 ms
Interfaces	
Number of PROFINET interfaces	1
1st interface	
• Interface types	
- Number of ports	2
- Integrated switch	Yes
- RJ 45 (Ethernet)	Yes
• Protocols	
- PROFINET IO Device	Yes
- Open IE communication	Yes
- Media redundancy	Yes
Interface types	
RJ 45 (Ethernet)	
• 10 Mbps	Yes; for Ethernet services
• 100 Mbps	Yes; PROFINET with 100 Mbit/s full duplex (100BASE-TX)
• Transmission procedure	PROFINET with 100 Mbit/s full duplex (100BASE-TX)
• Autonegotiation	Yes
• Autocrossing	Yes

6ES7 155-6AA00-0BN0 IM 155-6 PN ST with BA 2xRJ45 and server module	
Protocols	
Supports protocol for PROFINET IO	Yes
PROFINET IO Device	
• Services	
- Open IE communication	Yes
- IRT, supported	Yes
- Prioritized startup	Yes
- Shared device	Yes
Open IE communication	
• TCP/IP	Yes
• SNMP	Yes
• LLDP	Yes
Interrupts/diagnostics/status information	
Status indicator	Yes
Alarms	
• Alarms	Yes
Diagnostic messages	
• Diagnostic functions	Yes
Diagnostics indication LED	
• RUN LED	Yes; Green LED
• ERROR LED	Yes; Red LED
• MAINT LED	Yes; yellow LED
• Monitoring the supply voltage	Yes; Green LED
• Connection display LINK TX/RX	Yes
Isolation	
Isolation checked with	707 V DC between supply voltage and electronics 1500 V AC between Ethernet and electronics
Ambient conditions	
Operating temperature	
• horizontal installation, min.	0 °C
• horizontal installation, max.	60 °C
• vertical installation, min.	0 °C
• vertical installation, max.	50 °C
Dimensions	
Width	50 mm
Height	117 mm
Depth	74 mm
Weight	
Weight, approx.	191 g; IM155PN ST with BA 2xRJ45 (mounted)

SIMATIC ET 200 distributed I/O

ET 200SP

Interface modules without CPU
IM 155-6PN Standard

Ordering data	Order No.	Order No.
IM 155-6PN Standard interface module with server module and installed bus adapter BA 2xRJ45	6ES7 155-6AA00-0BN0	Manuals for ET 200SP distributed I/O system <ul style="list-style-type: none"> ET 200SP System Manual Manuals for interface modules, BaseUnits and I/O modules Manuals can be downloaded from the Internet as PDF files: www.siemens.com/simatic-docu
Accessories		
Bus adapter BA 2xRJ45	6ES7 193-6AR00-0AA0	SIMATIC Manual Collection Electronic manuals on DVD, multi-language: LOGO!, SIMADYN, SIMATIC bus components, SIMATIC C7, SIMATIC distributed I/O, SIMATIC HMI, SIMATIC Sensors, SIMATIC NET, SIMATIC PC Based Automation, SIMATIC PCS 7, SIMATIC PG/PC, SIMATIC S7, SIMATIC Software, SIMATIC TDC
Bus adapter BA 2xFC	6ES7193-6AF00-0AA0	
Reference identification label	6ES7 193-6LF30-0AW0	6ES7 998-8XC01-8YE0
10 sheets of 16 labels		
Labeling Strips	6ES7 193-6LR10-0AA0	SIMATIC Manual Collection update service for 1 year Current "Manual Collection" DVD and the three subsequent updates
1 roll of 500 strips		
IE FC RJ45 plugs		6ES7 998-8XC01-8YE2
RJ45 plug connector for Industrial Ethernet with a rugged metal enclosure and integrated insulation displacement contacts for connecting Industrial Ethernet FC installation cables		
IE FC RJ45 Plug 180		Spare parts
180° cable outlet		
1 unit	6GK1 901-1BB10-2AA0	Server module 6ES7 193-6PA00-0AA0
10 units	6GK1 901-1BB10-2AB0	
50 units	6GK1 901-1BB10-2AE0	
DIN rail 35 mm		Power supply connector for interface module for connecting the 24 V DC supply voltage with push-in terminals (10 units) 6ES7 193-4JB00-0AA0 with screw-type terminals (10 units) 6ES7 193-4JB50-0AA0
Length: 483 mm for 19" cabinets	6ES5 710-8MA11	
Length: 530 mm for 600 mm cabinets	6ES5 710-8MA21	
Length: 830 mm for 900 mm cabinets	6ES5 710-8MA31	
Length: 2 m	6ES5 710-8MA41	

SIMATIC ET 200 distributed I/O

ET 200SP

SIPLUS interface modules

Overview



- Interface module for linking the ET 200SP to PROFINET
- Handles all data exchange with the PROFINET I/O controller
- Bus Adapter (BA) for individual PROFINET connection
- Integrated 2-port switch for line configuration
- Max. 32 I/O modules
- Operation with gaps (non-equipped BaseUnits) possible
- Replacement of an I/O module possible during operation (single hot-swap)
- Load group formation without power module

Note:

SIPLUS extreme products are based on Siemens Industry standard products. The contents listed here were taken from the respective standard products. SIPLUS extreme specific information was added.

Technical specifications

	6AG1 155-6AA00-7BN0
	IM 155-6 PN ST with BA 2xRJ45 and server module
Based on	6ES7 155-6AA00-0BN0
Ambient conditions	
Operating temperature	
• Min.	-40 °C
• max.	70 °C
• horizontal installation, min.	-40 °C; = Tmin
• horizontal installation, max.	70 °C; = Tmax
• vertical installation, min.	-40 °C; = Tmin
• vertical installation, max.	50 °C; = Tmax
Extended ambient conditions	
• Relative to ambient temperature-atmospheric pressure-installation altitude	Tmin ... Tmax at 1080 hPa ... 795 hPa (-1000 m ... +2000 m) // Tmin ... (Tmax - 10K) at 795 hPa ... 658 hPa (+2000 m ... +3500 m) // Tmin ... (Tmax - 20K) at 658 hPa ... 540 hPa (+3500 m ... +5000 m)
• Relative humidity	100 %; RH incl. condensation/frost (no commissioning under condensation conditions)
- With condensation/maximum/ tested in accordance with IEC 60068-2-38	
• Resistance	
- to biologically active substances	Yes; Class 3B2 mold, fungus and dry rot spores (with the exception of fauna). The supplied connector covers must remain on the unused interfaces during operation!
- to chemically active substances	Yes; Class 3C4 (RH < 75%) incl. salt spray according to EN 60068-2-52 (degree of severity 3). The supplied connector covers must remain on the unused interfaces during operation!
- to mechanically active substances	Yes; Class 3S4 incl. sand, dust. The supplied connector covers must remain on the unused interfaces during operation!

Ordering data

Order No.

SIPLUS IM 155-6PN Standard interface module

6AG1 155-6AA00-7BN0

(Extended temperature range and medial exposure)

With server module and installed bus adapter BA 2xRJ45

Accessories

See SIMATIC ET 200SP, IM 155-6 PN Standard interface module, page 9/7

Overview



- 8- and 16-channel digital input modules for the ET 200SP
- Can be plugged into Type A0 BaseUnits (BU) with automatic coding
- LED display for error, operation, supply voltage and status
- Clear labeling on front of module
 - Plain text identification of the module type and function class
 - 2D matrix code (order and serial number)
 - Connection diagram
 - Color coding of the module type DI: White
 - Hardware and firmware version
 - Color code CC for module-specific color coding of the potentials at the terminals of the BU
 - Complete order number
- Optional labeling accessories
 - Labeling Strips
 - Reference identification label
- Optional module-specific color identification of the terminals according to the color code CC

Technical specifications

	6ES7 131-6BF00-0BA0 DI 8x24VDC ST	6ES7 131-6BH00-0BA0 DI 16x24VDC ST
General information		
Product function		
• I&M data	Yes	Yes
Engineering with		
• STEP 7 TIA Portal can be configured/integrated as of version	as of V11.0 SP2 with HSP0024 / -	as of V11.0 SP2 with HSP0024 / -
• STEP 7 can be configured/integrated as of version	V5.5 SP2 or higher with a GSD file / -	V5.5 SP2 or higher with a GSD file / -
Supply voltage		
Type of supply voltage	DC	DC
Rated voltage/DC	24 V	24 V
Reverse polarity protection	Yes	Yes
Encoder supply		
24 V encoder supply		
• 24 V	Yes	
• Short-circuit protection	Yes	
• Output current, max.	700 mA	
Digital inputs		
Number/binary inputs	8	16
Input characteristic curve acc. to IEC 61131, Type 1	Yes	Yes
Input characteristic curve acc. to IEC 61131, Type 3	Yes	Yes
Input voltage		
• Type of input voltage	DC	DC
• Rated value, DC	24 V	24 V
• for signal "0"	-30 to 5 V	-30 to 5 V
• for signal "1"	11 to 30 V	11 to 30 V
Input current		
• for signal "1", typ.	2.5 mA	2.5 mA
Input delay (for rated value of input voltage)		
• for standard inputs - Parameterizable	Yes; 0.05 / 0.1 / 0.4 / 0.8 / 1.6 / 3.2 / 12.8 / 20 ms (in each case + delay of 30 to 500 µs, depending on line length)	Yes; 0.05 / 0.1 / 0.4 / 0.8 / 1.6 / 3.2 / 12.8 / 20 ms (in each case + delay of 30 to 500 µs, depending on line length)
Cable length		
• Cable length, shielded, max.	1 000 m	1 000 m
• Cable length unshielded, max.	200 m	200 m
Encoder		
Connectable encoders		
• 2-wire sensor - Permissible quiescent current (2-wire sensor), max.	Yes 1.5 mA	Yes 1.5 mA

SIMATIC ET 200 distributed I/O

ET 200SP

I/O modules

Digital input modules

Technical specifications (continued)

	6ES7 131-6BF00-0BA0 DI 8x24VDC ST	6ES7 131-6BH00-0BA0 DI 16x24VDC ST
Interrupts/diagnostics/ status information		
Alarms		
• Diagnostic alarm	Yes	Yes
Diagnostic messages		
• Diagnostics	Yes	Yes
• Monitoring the supply voltage	Yes	Yes
• Wire break	Yes	Yes
• Short circuit	Yes	Yes
Diagnosics indication LED		
• Monitoring the supply voltage	Yes; green PWR LED	Yes; green PWR LED
• Channel status display	Yes; Green LED	Yes; Green LED
• for module diagnostics	Yes; green/red DIAG LED	Yes; green/red DIAG LED
Galvanic isolation		
Electrical isolation channels		
• between the channels and the backplane bus	Yes	Yes
Isolation		
Isolation checked with	707 V DC (type test)	707 V DC (type test)
Ambient conditions		
Operating temperature		
• horizontal installation, min.	0 °C	0 °C
• horizontal installation, max.	60 °C	60 °C
• vertical installation, min.	0 °C	0 °C
• vertical installation, max.	50 °C	50 °C
Dimensions		
Width	15 mm	15 mm
Weight		
Weight, approx.	28 g	28 g

9

Ordering data

Digital input modules

DI 8x24 V DC Standard,
BU type A0, color code CC01

6ES7 131-6BF00-0BA0

DI 8x24 V DC High Feature,
BU type A0, color code CC01

6ES7 131-6BF00-0CA0

DI 16x24 V DC Standard,
BU type A0, color code CC00

6ES7 131-6BH00-0BA0

Usable BaseUnits

BU15-P16+A0+2D

BU type A0; BaseUnit (light) with
16 process terminals to the module;
for starting a new load group
(max. 10 A)

6ES7 193-6BP00-0DA0

BU15-P16+A0+2B

BU type A0; BaseUnit (dark) with
16 process terminals to the module;
for continuing the load group

6ES7 193-6BP00-0BA0

BU15-P16+A10+2D

BU type A0; BaseUnit (light) with
16 process terminals (1 ... 16) on the
module and an additional 10 inter-
nally jumpered AUX terminals
(1 A to 10 A);
for starting a new load group
(max. 10 A)

6ES7 193-6BP20-0DA0

BU15-P16+A10+2B

BU type A0; BaseUnit (dark) with
16 process terminals (1 ... 16) on the
module and an additional 10 inter-
nally jumpered AUX terminals
(1 A to 10 A);
for continuing the load group

6ES7 193-6BP20-0BA0

Accessories

Reference identification label
10 sheets of 16 labels

6ES7 193-6LF30-0AW0

Labeling strips
1 roll of 500 strips

6ES7 193-6LR10-0AA0

BU cover, 15 mm
for covering empty slots (gaps);
5 units

6ES7 133-6CV15-1AM0

Shield connection
5 shield supports and
5 shield terminals

6ES7 193-6SC00-1AM0

Color-coding plates

• Color code CC01,
module-specific,
for 16 push-in terminals; 10 units

6ES7 193-6CP01-2MA0

• Color code CC71,
for 10 AUX terminals,
for BU type A0,
with push-in terminals; 10 units

6ES7 193-6CP71-2AA0

• Color code CC72,
for 10 AUX terminals,
for BU type A0,
with push-in terminals; 10 units

6ES7 193-6CP72-2AA0

• Color code CC73,
for 10 AUX terminals,
for BU type A0,
with push-in terminals; 10 units

6ES7 193-6CP73-2AA0

Overview



- 4-, 8- and 16-channel digital output modules for the ET 200SP
- Can be plugged into Type A0 BaseUnits (BU) with automatic coding
- LED display for error, operation, supply voltage and status
- Clear labeling on front of module
 - Plain text identification of the module type and function class
 - 2D matrix code (order and serial number)
 - Connection diagram
 - Color coding of the module type DQ: black
 - Hardware and firmware version
 - Color code CC for module-specific color coding of the potentials at the terminals of the BU
 - Complete order number
- Optional labeling accessories
 - Labeling strips
 - Reference identification label
- Optional module-specific color identification of the terminals according to the color code CC

Technical specifications

	6ES7 132-6BD20-0BA0 DQ 4x24VDC/2A ST	6ES7 132-6BF00-0BA0 DQ 8x24VDC/0.5A ST	6ES7 132-6BH00-0BA0 DQ 16x24VDC/0.5A ST
General information			
Product function			
• I&M data	Yes	Yes	Yes
Engineering with			
• STEP 7 TIA Portal can be configured/integrated as of version	as of V11.0 SP2 with HSP0024 / -	as of V11.0 SP2 with HSP0024 / -	as of V11.0 SP2 with HSP0024 / -
• STEP 7 can be configured/integrated as of version	V5.5 SP2 or higher with a GSD file / -	V5.5 SP2 or higher with a GSD file / -	V5.5 SP2 or higher with a GSD file / -
Supply voltage			
Type of supply voltage	DC	DC	DC
Rated voltage/DC	24 V	24 V	24 V
Reverse polarity protection	Yes	Yes	Yes
Digital outputs			
Number/binary outputs	4	8	16
Functionality/short-circuit strength	Yes	Yes	Yes
Limitation of inductive shutdown voltage to	Typ. L+ (-50 V)	Typ. L+ (-50 V)	Typ. L+ (-50 V)
Controlling a digital input	Yes	Yes	Yes
Switching capacity of the outputs			
• with resistive load, max.	2 A	0.5 A	0.5 A
• on lamp load, max.	10 W	5 W	5 W
Load resistance range			
• lower limit	12 Ω	48 Ω	48 Ω
• upper limit	3 400 Ω	12 kΩ	12 kΩ
Output current			
• for signal "1" rated value	2 A	0.5 A	0.5 A
• for signal "0" residual current, max.	0.1 mA	0.1 mA	0.1 mA
Output delay with resistive load			
• "0" to "1", typ.	50 μs	50 μs	50 μs
• "1" to "0", typ.	100 μs	100 μs	100 μs
Parallel switching of 2 outputs			
• for increased power	No	No	No
• for redundant control of a load	Yes	Yes	Yes
Switching frequency			
• with resistive load, max.	100 Hz	100 Hz	100 Hz
• with inductive load, max.	2 Hz	2 Hz	2 Hz
• on lamp load, max.	10 Hz	10 Hz	10 Hz
Aggregate current of the outputs			
• Max. current per module	8 A	4 A	8 A

SIMATIC ET 200 distributed I/O

ET 200SP

I/O module

Digital output modules

Technical specifications (continued)

	6ES7 132-6BD20-0BA0 DQ 4x24VDC/2A ST	6ES7 132-6BF00-0BA0 DQ 8x24VDC/0.5A ST	6ES7 132-6BH00-0BA0 DQ 16x24VDC/0.5A ST
Cable length			
• Cable length, shielded, max.	1 000 m	1 000 m	1 000 m
• Cable length unshielded, max.	200 m	200 m	200 m
Interrupts/diagnostics/ status information			
Substitute values connectable	Yes	Yes	Yes
Alarms			
• Diagnostic alarm	Yes	Yes	Yes
Diagnostic messages			
• Monitoring the supply voltage	Yes	Yes	Yes
• Wire break	Yes	Yes	Yes
• Short circuit	Yes	Yes	Yes
Diagnostics indication LED			
• Monitoring the supply voltage	Yes; green PWR LED	Yes; green PWR LED	Yes; green PWR LED
• Channel status display	Yes; Green LED	Yes; Green LED	Yes; Green LED
• for module diagnostics	Yes; green/red DIAG LED	Yes; green/red DIAG LED	Yes; green/red DIAG LED
Galvanic isolation			
Electrical isolation channels			
• between the channels and the backplane bus	Yes	Yes	Yes
Isolation			
Isolation checked with	707 V DC (type test)	707 V DC (type test)	707 V DC (type test)
Standards, approvals, certificates			
SIL according to IEC 61508	2	2	2
Highest safety class achievable in safety mode			
• Performance Level in accordance with EN ISO 13849-1	d	d	d
Ambient conditions			
Operating temperature			
• horizontal installation, min.	0 °C	0 °C	0 °C
• horizontal installation, max.	60 °C	60 °C	60 °C
• vertical installation, min.	0 °C	0 °C	0 °C
• vertical installation, max.	50 °C	50 °C	50 °C
Dimensions			
Width	15 mm	15 mm	15 mm
Weight			
Weight, approx.	30 g	28 g	28 g

Ordering data	Order No.	Order No.
Digital output modules		Accessories
RQ 4x120 V AC...230 V AC/5 A Standard, BU type B0, color code CC00	6ES7 132-6HD00-0BB0	Reference identification label 10 sheets of 16 labels
DQ 4x24VDC/2A Standard, BU type A0, color code CC02	6ES7 132-6BD20-0BA0	Labeling Strips 1 roll of 500 strips
DQ 8x24VDC/0.5A Standard, BU type A0, color code CC02	6ES7 132-6BF00-0BA0	BU cover, 15 mm for covering empty slots (gaps); 5 units
DQ 8x24 V DC/0.5A High Feature, BU type A0, color code CC02	6ES7 132-6BF00-0CA0	Shield connection 5 shield supports and 5 shield terminals
DQ 16x24 V DC/0.5 A Standard, BU type A0, color code CC00	6ES7 132-6BH00-0BA0	Color-coding plates
Usable BaseUnits		<ul style="list-style-type: none"> Color code CC02, module-specific, for 16 push-in terminals; 10 units Color code CC71, for 10 AUX terminals, for BU type A0, with push-in terminals; 10 units Color code CC72, for 10 AUX terminals, for BU type A0, with push-in terminals; 10 units Color code CC73, for 10 AUX terminals, for BU type A0, with push-in terminals; 10 units
BU15-P16+A0+2D BU type A0; BaseUnit (light) with 16 process terminals to the module; for starting a new load group (max. 10 A)	6ES7 193-6BP00-0DA0	6ES7 193-6LF30-0AW0
BU15-P16+A0+2B BU type A0; BaseUnit (dark) with 16 process terminals to the module; for continuing the load group	6ES7 193-6BP00-0BA0	6ES7 193-6LR10-0AA0
BU15-P16+A10+2D BU type A0; BaseUnit (light) with 16 process terminals (1 ... 16) on the module and an additional 10 internally jumpered AUX terminals (1 A to 10 A); for starting a new load group (max. 10 A)	6ES7 193-6BP20-0DA0	6ES7 133-6CV15-1AM0
BU15-P16+A10+2B BU type A0; BaseUnit (dark) with 16 process terminals (1 ... 16) on the module and an additional 10 internally jumpered AUX terminals (1 A to 10 A); for continuing the load group	6ES7 193-6BP20-0BA0	6ES7 193-6CP02-2MA0
BU20-P12+A4+0B BU type B0; BaseUnit (dark) with 12 process terminals (1...12) to the module and additionally 4 internally jumpered AUX terminals (1 A to 4 A); for continuing the load group	6ES7 193-6BP20-0BB0	6ES7 193-6CP71-2AA0
		6ES7 193-6CP72-2AA0
		6ES7 193-6CP73-2AA0

SIMATIC ET 200 distributed I/O

ET 200SP

SIPLUS digital input modules

Overview



- 8- and 16-channel digital input modules for the ET 200SP
- Can be plugged into Type A0 BaseUnits (BU) with automatic coding

- LED display for error, operation, supply voltage and status
- Clear labeling on front of module
 - Plain text identification of the module type and function class
 - 2D matrix code (order and serial number)
 - Connection diagram
 - Color coding of the module type DI: White
 - Hardware and firmware version
 - Color code CC for module-specific color coding of the potentials at the terminals of the BU
 - Complete order number
- Optional labeling accessories
 - Labeling Strips
 - Reference identification label
- Optional module-specific color identification of the terminals according to the color code CC

Note:

SIPLUS extreme products are based on Siemens Industry standard products. The contents listed here were taken from the respective standard products. SIPLUS extreme specific information was added.

Technical specifications

The technical data correspond to those of the based-on modules apart from the values listed in the table.

	6AG1 131-6BF00-7BA0 DI 8x24VDC ST	6AG1 131-6BH00-7BA0 DI 16x24VDC ST
Based on	6ES7 131-6BF00-0BA0	6ES7 131-6BH00-0BA0
Ambient conditions		
Operating temperature		
• Min.	-40 °C	-40 °C
• max.	70 °C	70 °C
• horizontal installation, min.	-40 °C; = Tmin	-40 °C; = Tmin
• horizontal installation, max.	70 °C; = Tmax; > +60 °C number of simultaneously controllable inputs max. 6	70 °C; = Tmax; > +60 °C number of simultaneously controllable inputs max. 4
• vertical installation, min.	-40 °C; = Tmin	-40 °C; = Tmin
• vertical installation, max.	50 °C; = Tmax	50 °C; = Tmax
Extended ambient conditions		
• Relative to ambient temperature-atmospheric pressure-installation altitude	Tmin ... Tmax at 1080 hPa ... 795 hPa (-1000 m ... +2000 m) // Tmin ... (Tmax - 10K) at 795 hPa ... 658 hPa (+2000 m ... +3500 m) // Tmin ... (Tmax - 20K) at 658 hPa ... 540 hPa (+3500 m ... +5000 m)	Tmin ... Tmax at 1080 hPa ... 795 hPa (-1000 m ... +2000 m) // Tmin ... (Tmax - 10K) at 795 hPa ... 658 hPa (+2000 m ... +3500 m) // Tmin ... (Tmax - 20K) at 658 hPa ... 540 hPa (+3500 m ... +5000 m)
• Relative humidity		
- With condensation/maximum/ tested in accordance with IEC 60068-2-38	100 %; RH incl. condensation/frost (no commissioning under condensation conditions)	100 %; RH incl. condensation/frost (no commissioning under condensation conditions)
• Resistance		
- to biologically active substances	Yes; Class 3B2 mold, fungus and dry rot spores (with the exception of fauna). The supplied connector covers must remain on the unused interfaces during operation!	Yes; Class 3B2 mold, fungus and dry rot spores (with the exception of fauna). The supplied connector covers must remain on the unused interfaces during operation!
- to chemically active substances	Yes; Class 3C4 (RH < 75%) incl. salt spray according to EN 60068-2-52 (degree of severity 3). The supplied connector covers must remain on the unused interfaces during operation!	Yes; Class 3C4 (RH < 75%) incl. salt spray according to EN 60068-2-52 (degree of severity 3). The supplied connector covers must remain on the unused interfaces during operation!
- to mechanically active substances	Yes; Class 3S4 incl. sand, dust. The supplied connector covers must remain on the unused interfaces during operation!	Yes; Class 3S4 incl. sand, dust. The supplied connector covers must remain on the unused interfaces during operation!

Ordering data	Order No.	Order No.
SIPLUS digital input modules (Extended temperature range and medial exposure) DI 8x24 V DC Standard, BU type A0, color code CC01 DI 16x24 V DC Standard, BU type A0, color code CC00	6AG1 131-6BF00-7BA0 6AG1 131-6BH00-7BA0	6AG1 193-6BP20-7DA0
Usable SIPLUS BaseUnits BU15-P16+A0+2D (Extended temperature range and medial exposure) BU type A0; BaseUnit (light) with 16 process terminals to the module; for starting a new load group (max. 10 A)	6AG1 193-6BP00-7DA0	6AG1 193-6BP20-7BA0
BU15-P16+A0+2B (Extended temperature range and medial exposure) BU type A0; BaseUnit (dark) with 16 process terminals to the module; for continuing the load group	6AG1 193-6BP00-7BA0	6AG1 193-6BP20-7BA0
	Accessories	See SIMATIC ET 200SP, digital input modules, page 9/10

SIMATIC ET 200 distributed I/O

ET 200SP

SIPLUS digital output modules

Overview



- 4-, 8- and 16-channel digital output modules for the ET 200SP
- Can be plugged into Type A0 BaseUnits (BU) with automatic coding

- LED display for error, operation, supply voltage and status
- Clear labeling on front of module
 - Plain text identification of the module type and function class
 - 2D matrix code (order and serial number)
 - Connection diagram
 - Color coding of the module type DQ: black
 - Hardware and firmware version
 - Color code CC for module-specific color coding of the potentials at the terminals of the BU
 - Complete order number
- Optional labeling accessories
 - Labeling strips
 - Reference identification label
- Optional module-specific color identification of the terminals according to the color code CC

Note:

SIPLUS extreme products are based on Siemens Industry standard products. The contents listed here were taken from the respective standard products. SIPLUS extreme specific information was added.

Technical specifications

The technical data correspond to those of the based-on modules apart from the values listed in the table.

	6AG1 132-6BD20-7BA0 DQ 4x24VDC/2A ST	6AG1 132-6BF00-7BA0 DQ 8x24VDC/0.5A ST	6AG1 132-6BH00-7BA0 DQ 16x24VDC/0.5A ST
Based on	6ES7 132-6BD20-0BA0	6ES7 132-6BF00-0BA0	6ES7 132-6BH00-0BA0
Ambient conditions			
Operating temperature			
• Min.	-40 °C; = Tmin	-40 °C; = Tmin	-40 °C; = Tmin
• max.	70 °C; = Tmax	70 °C; = Tmax	70 °C; = Tmax
• horizontal installation, min.	-40 °C	-40 °C; = Tmin	-40 °C; = Tmin
• horizontal installation, max.	70 °C; = Tmax; > +60 °C number of simultaneously controllable outputs max. 2 x 0.25 A or max. 4 x 0.125 A, max. total current 0.5 A	70 °C; = Tmax; > +60 °C max. total current 1.0 A	70 °C; = Tmax; > +60 °C max. total current 1.0 A
• vertical installation, min.	-40 °C	-40 °C; = Tmin	-40 °C; = Tmin
• vertical installation, max.	50 °C	50 °C; = Tmax	50 °C; = Tmax
Extended ambient conditions			
• Relative to ambient temperature-atmospheric pressure-installation altitude	Tmin ... Tmax at 1080 hPa ... 795 hPa (-1000 m ... +2000 m) // Tmin ... (Tmax - 10K) at 795 hPa ... 658 hPa (+2000 m ... +3500 m) // Tmin ... (Tmax - 20K) at 658 hPa ... 540 hPa (+3500 m ... +5000 m)	Tmin ... Tmax at 1080 hPa ... 795 hPa (-1000 m ... +2000 m) // Tmin ... (Tmax - 10K) at 795 hPa ... 658 hPa (+2000 m ... +3500 m) // Tmin ... (Tmax - 20K) at 658 hPa ... 540 hPa (+3500 m ... +5000 m)	Tmin ... Tmax at 1080 hPa ... 795 hPa (-1000 m ... +2000 m) // Tmin ... (Tmax - 10K) at 795 hPa ... 658 hPa (+2000 m ... +3500 m) // Tmin ... (Tmax - 20K) at 658 hPa ... 540 hPa (+3500 m ... +5000 m)
• Relative humidity			
- With condensation/maximum/ tested in accordance with IEC 60068-2-38	100 %; RH incl. condensation/frost (no commissioning under condensation conditions)	100 %; RH incl. condensation/frost (no commissioning under condensation conditions)	100 %; RH incl. condensation/frost (no commissioning under condensation conditions)
• Resistance			
- to biologically active substances	Yes; Class 3B2 mold, fungus and dry rot spores (with the exception of fauna). The supplied connector covers must remain on the unused interfaces during operation!	Yes; Class 3B2 mold, fungus and dry rot spores (with the exception of fauna). The supplied connector covers must remain on the unused interfaces during operation!	Yes; Class 3B2 mold, fungus and dry rot spores (with the exception of fauna). The supplied connector covers must remain on the unused interfaces during operation!
- to chemically active substances	Yes; Class 3C4 (RH < 75%) incl. salt spray according to EN 60068-2-52 (degree of severity 3). The supplied connector covers must remain on the unused interfaces during operation!	Yes; Class 3C4 (RH < 75%) incl. salt spray according to EN 60068-2-52 (degree of severity 3). The supplied connector covers must remain on the unused interfaces during operation!	Yes; Class 3C4 (RH < 75%) incl. salt spray according to EN 60068-2-52 (degree of severity 3). The supplied connector covers must remain on the unused interfaces during operation!
- to mechanically active substances	Yes; Class 3S4 incl. sand, dust. The supplied connector covers must remain on the unused interfaces during operation!	Yes; Class 3S4 incl. sand, dust. The supplied connector covers must remain on the unused interfaces during operation!	Yes; Class 3S4 incl. sand, dust. The supplied connector covers must remain on the unused interfaces during operation!

Ordering data	Order No.	Order No.
<p>SIPLUS digital output modules</p> <p>(Extended temperature range and medial exposure)</p> <p>DQ 4x24VDC/2A Standard, BU type A0, color code CC02</p> <p>DQ 8x24VDC/0.5A Standard, BU type A0, color code CC02</p> <p>DQ 16x24 V DC/0.5 A Standard, BU type A0, color code CC00</p>	<p>6AG1 132-6BD20-7BA0</p> <p>6AG1 132-6BF00-7BA0</p> <p>6AG1 132-6BH00-7BA0</p>	<p>6AG1 193-6BP20-7DA0</p>
<p>Usable SIPLUS BaseUnits</p> <p>BU15-P16+A0+2D</p> <p>(Extended temperature range and medial exposure)</p> <p>BU type A0; BaseUnit (light) with 16 process terminals to the module; for starting a new load group (max. 10 A)</p>	<p>6AG1 193-6BP00-7DA0</p>	<p>6AG1 193-6BP20-7BA0</p>
<p>BU15-P16+A0+2B</p> <p>(Extended temperature range and medial exposure)</p> <p>BU type A0; BaseUnit (dark) with 16 process terminals to the module; for continuing the load group</p>	<p>6AG1 193-6BP00-7BA0</p>	<p>6AG1 193-6BP20-7BA0</p>
		<p>Accessories</p> <p>See SIMATIC ET 200SP, digital output modules, page 9/13</p>

SIMATIC ET 200 distributed I/O

ET 200SP

I/O modules

Analog input modules

Overview



- 4-channel analog input modules for the ET 200SP
- Can be plugged into type A0 or A1 BaseUnits (BU) with automatic coding
- LED display for error, operation, supply voltage and status
- Clear labeling on front of module
 - Plain text identification of the module type and function class
 - 2D matrix code (order and serial number)
 - Connection diagram
 - Color coding of the module type AI: Light blue
 - Hardware and firmware version
 - Color code CC for module-specific color coding of the potentials at the terminals of the BU
 - Complete order number
- Optional labeling accessories
 - Labeling strips
 - Reference identification label
- Optional module-specific color identification of the terminals according to the color code CC

Technical specifications

	6ES7 134-6HD00-0BA1 AI 4xU/I 2-wire ST	6ES7 134-6GD00-0BA1 AI 4xI 2-/4-wire ST	6ES7 134-6JD00-0CA1 AI 4xRTD/TC 2-/3-/4-wire HF
General information			
Product function			
• I&M data	Yes	Yes	Yes
Engineering with			
• STEP 7 TIA Portal can be configured/integrated as of version	as of V11.0 SP2 with HSP0024 / -	as of V11.0 SP2 with HSP0024 / -	as of V11.0 SP2 with HSP0024 / -
• STEP 7 can be configured/integrated as of version	V5.5 SP2 or higher with a GSD file / -	V5.5 SP2 or higher with a GSD file / -	V5.5 SP2 or higher with a GSD file / -
Supply voltage			
Rated voltage/DC	24 V	24 V	24 V
Reverse polarity protection	Yes	Yes	Yes
Analog inputs			
Number of analog inputs	4	4	4
permissible input voltage for voltage input (destruction limit), max.	30 V		30 V
Constant measurement current for resistance-type transmitter, typ.			2 mA
Cycle time (all channels), min.	Sum of the basic conversion times and additional processing times (depending on the parameterization of the active channels)	Sum of the basic conversion times and additional processing times (depending on the parameterization of the active channels)	Sum of the basic conversion times and additional processing times (depending on the parameterization of the active channels); for line compensation in case of a three-wire connection, an additional cycle is necessary
Technical unit for temperature measurement adjustable			Yes
Input ranges (rated values), voltages			
• 0 to +10 V	Yes; 15 bit		
• 1 to 5 V	Yes; 15 bit		
• -1 V to +1 V			Yes; 16 bit incl. sign
• -10 V to +10 V	Yes; 16 bit incl. sign		
• -250 mV to +250 mV			Yes; 16 bit incl. sign
• -5 V to +5 V	Yes; 16 bit incl. sign		
• -50 mV to +50 mV			Yes; 16 bit incl. sign
• -80 mV to +80 mV			Yes; 16 bit incl. sign
Input ranges (rated values), currents			
• 0 to 20 mA	Yes; 15 bit	Yes; 15 bit	
• -20 to +20 mA		Yes; 16 bit incl. sign	
• 4 to 20 mA	Yes; 15 bit	Yes; 15 bit	

Technical specifications (continued)

	6ES7 134-6HD00-0BA1 AI 4xU/I 2-wire ST	6ES7 134-6GD00-0BA1 AI 4xI 2-/4-wire ST	6ES7 134-6JD00-0CA1 AI 4xRTD/TC 2-/3-/4-wire HF
Input ranges (rated values), thermoelements <ul style="list-style-type: none"> • Type B • Type C • Type E • Type J • Type K • Type L • Type N • Type R • Type S • Type T • Type U • Type TXK/TXK(L) to GOST 			Yes; 16 bit incl. sign Yes; 16 bit incl. sign Yes; 16 bit incl. sign Yes; 16 bit incl. sign Yes; 16 bit incl. sign Yes; 16 bit incl. sign Yes; 16 bit incl. sign Yes; 16 bit incl. sign Yes; 16 bit incl. sign Yes; 16 bit incl. sign Yes; 16 bit incl. sign
Input ranges (rated values), resistance thermometers <ul style="list-style-type: none"> • Cu 10 • Ni 100 • Ni 1000 • LG-Ni 1000 • Ni 120 • Ni 200 • Ni 500 • Pt 100 • Pt 1000 • Pt 200 • Pt 500 			Yes; 16 bit incl. sign Yes; 16 bit incl. sign Yes; 16 bit incl. sign Yes; 16 bit incl. sign Yes; 16 bit incl. sign Yes; 16 bit incl. sign Yes; 16 bit incl. sign Yes; 16 bit incl. sign Yes; 16 bit incl. sign Yes; 16 bit incl. sign Yes; 16 bit incl. sign
Input ranges (rated values), resistors <ul style="list-style-type: none"> • 0 to 150 ohms • 0 to 300 ohms • 0 to 600 ohms • 0 to 3000 ohms • 0 to 6000 ohms • PTC 			Yes; 15 bit Yes; 15 bit Yes; 15 bit Yes; 15 bit Yes; 15 bit Yes; 15 bit
Thermocouple (TC) <ul style="list-style-type: none"> • Technical unit for temperature measurement • Temperature compensation - Parameterizable 			°C/°F/K Yes
Resistance thermometer (RTD) <ul style="list-style-type: none"> • permissible input voltage for voltage input (destruction limit), max. • Technical unit for temperature measurement 			30 V °C/°F/K
Cable length <ul style="list-style-type: none"> • Cable length, shielded, max. 	200 m	200 m	200 m; 50 m with thermocouples
Analog value creation Integrations and conversion time/ resolution per channel <ul style="list-style-type: none"> • Resolution with overrange (bit including sign), max. • Integration time, parameterizable • Basic conversion time, including integration time, ms - Additional processing time for wire-break check - Additional power line wire-break check • Interference voltage suppression for interference frequency f1 in Hz • Conversion time (per channel) 	16 bit Yes	16 bit Yes	16 bit Yes 2 ms; In the ranges resistance thermometers, resistors and thermocouples 2 ms; for 3/4 wire transducer (resistance thermometer and resistor) 16.6 / 50 / 60 Hz 180 / 60 / 50 ms
Smoothing of measured values <ul style="list-style-type: none"> • Parameterizable 	Yes	Yes	Yes

SIMATIC ET 200 distributed I/O

ET 200SP

I/O modules

Analog input modules

Technical specifications (continued)

	6ES7 134-6HD00-0BA1 AI 4xU/I 2-wire ST	6ES7 134-6GD00-0BA1 AI 4xI 2-/4-wire ST	6ES7 134-6JD00-0CA1 AI 4xRTD/TC 2-/3-/4-wire HF
Encoder			
Connection of signal encoders			
• for voltage measurement	Yes		Yes
• for current measurement as 2-wire transducer	Yes	Yes	
• Burden of 2-wire transmitter, max.	650 Ω	650 Ω	
• for current measurement as 4-wire transducer		Yes	
• for resistance measurement with 2-conductor connection			Yes
• for resistance measurement with 3-conductor connection			Yes
• for resistance measurement with 4-conductor connection			Yes
Errors/accuracies			
Interference voltage suppression for $f = n \times (f_1 \pm 1\%)$, $f_1 =$ interference frequency			
• Series mode interference (peak value of interference < rated value of input range), min.	70 dB	70 dB	70 dB
• common mode voltage, max.	10 V	10 V	10 V
• Common mode interference, min.	90 dB	90 dB	90 dB
Interrupts/diagnostics/status information			
Alarms			
• Diagnostic alarm	Yes	Yes	Yes
• Limit value alarm			Yes; two upper and two lower limit values in each case
Diagnostic messages			
• Diagnostics	Yes	Yes	Yes
• Monitoring the supply voltage	Yes	Yes	Yes
• Wire break	Yes; at 4 to 20 mA	Yes; at 4 to 20 mA	Yes
• Short circuit	Yes; with 1 to 5 V or 2-wire mode: Short-circuit of the encoder supply to ground or of an input to the encoder supply	Yes; 2-wire mode: Short-circuit of the encoder supply to ground or of an input to the encoder supply	
• Overflow/underflow	Yes	Yes	Yes
Diagnostics indication LED			
• Monitoring the supply voltage	Yes; Green LED	Yes; Green LED	Yes; Green LED
• Channel status display	Yes; Green LED	Yes; Green LED	Yes; Green LED
• for channel diagnostics			Yes; Red LED
• for module diagnostics	Yes; Green/red LED	Yes; Green/red LED	Yes; Green/red LED
Galvanic isolation			
Electrical isolation channels			
• between the channels and the backplane bus	Yes	Yes	Yes
Isolation			
Isolation checked with	707 V DC (type test)	707 V DC (type test)	707 V DC (type test)

Technical specifications (continued)

	6ES7 134-6HD00-0BA1 AI 4xU/I 2-wire ST	6ES7 134-6GD00-0BA1 AI 4xI 2-/4-wire ST	6ES7 134-6JD00-0CA1 AI 4xRTD/TC 2-/3-/4-wire HF
Ambient conditions			
Operating temperature			
• horizontal installation, min.	0 °C	0 °C	0 °C
• horizontal installation, max.	60 °C	60 °C	60 °C
• vertical installation, min.	0 °C	0 °C	0 °C
• vertical installation, max.	50 °C	50 °C	50 °C
Dimensions			
Width	15 mm	15 mm	15 mm
Height			73 mm
Depth			58 mm
Weight			
Weight, approx.	31 g	31 g	30 g

Ordering data

Order No.	Order No.
Analog input modules	BU15-P16+A0+12D/T
AI 4XU/I 2-wire Standard BU type A0 or A1, color code CC03	6ES7 134-6HD00-0BA1
AI 4xI 2-, 4-wire Standard, BU type A0 or A1, color code CC03	6ES7 134-6GD00-0BA1
AI 4xRTD/TC 2-, 3-, 4-wire High Feature BU type A0 or A1, color code CC00	6ES7 134-6JD00-0CA1
Usable type A0 BaseUnits	Accessories
BU15-P16+A0+2D	Reference identification label
BU type A0; BaseUnit (light) with 16 process terminals to the module; for starting a new load group (max. 10 A)	6ES7 193-6BP40-0DA1
BU15-P16+A0+2B	10 sheets of 16 labels
BU type A0; BaseUnit (dark) with 16 process terminals to the module; for continuing the load group	Labeling strips
BU15-P16+A10+2D	6ES7 193-6BP00-0DA0
BU type A0; BaseUnit (light) with 16 process terminals (1 ... 16) on the module and an additional 10 inter- nally jumpered AUX terminals (1 A to 10 A); for starting a new load group (max. 10 A)	1 roll of 500 strips
BU15-P16+A10+2B	BU cover, 15 mm
BU type A0; BaseUnit (dark) with 16 process terminals (1 ... 16) on the module and an additional 10 internally jumpered AUX termi- nals (1 A to 10 A); for continuing the load group	6ES7 133-6CV15-1AM0
Usable type A1 BaseUnits (temperature detection)	Shield connection
BU15-P16+A0+2D/T	6ES7 193-6SC00-1AM0
BU type A1; BaseUnit (light) with 16 process terminals to the module; for starting a new load group (max. 10 A)	5 shield supports and 5 shield terminals
BU15-P16+A0+2B/T	Color-coding plates
BU type A1; BaseUnit (dark) with 16 process terminals to the module; for continuing the load group	• Color code CC03, module-specific, for 16 push-in terminals; 10 units
	6ES7 193-6CP03-2MA0
	• Color code CC71, for 10 AUX terminals, for BU type A0, with push-in terminals; 10 units
	6ES7 193-6CP71-2AA0
	• Color code CC72, for 10 AUX terminals, for BU type A0, with push-in terminals; 10 units
	6ES7 193-6CP72-2AA0
	• Color code CC73, for 10 AUX terminals, for BU type A0, with push-in terminals; 10 units
	6ES7 193-6CP73-2AA0
	• Color code CC74, for 2x5 additional terminals, for BU type A1, with push-in terminals; 10 units
	6ES7 193-6CP74-2AA0

SIMATIC ET 200 distributed I/O

ET 200SP

I/O modules

Analog output modules

Overview



- 4-channel analog input modules for the ET 200SP
- Can be plugged into Type A0 or A1 BaseUnits (BU) with automatic coding
- LED display for error, operation, supply voltage and status
- Clear labeling on front of module
 - Plain text identification of the module type and function class
 - 2D matrix code (order and serial number)
 - Connection diagram
 - Color coding of the module type AQ: dark blue
 - Hardware and firmware version
 - Color code CC for module-specific color coding of the potentials at the terminals of the BU
 - Complete order number
- Optional labeling accessories
 - Labeling strips
 - Reference identification label
- Optional module-specific color identification of the terminals according to the color code CC

Technical specifications

6ES7 135-6HD00-0BA1 AQ 4xU/I ST	
General information	
Product function	
• I&M data	Yes
Engineering with	
• STEP 7 TIA Portal can be configured/integrated as of version	as of V11.0 SP2 with HSP0024 / -
• STEP 7 can be configured/integrated as of version	V5.5 SP2 or higher with a GSD file / -
Supply voltage	
Type of supply voltage	DC
Rated voltage/DC	24 V
Reverse polarity protection	Yes
Analog outputs	
Number of analog outputs	4
Cycle time (all channels), min.	5 ms
Output ranges, voltage	
• 0 to 10 V	Yes; 15 bit
• 1 to 5 V	Yes; 13 bit
• -5 to +5 V	Yes; 15 bit incl. sign
• -10 to +10 V	Yes; 16 bit incl. sign
Output ranges, current	
• 0 to 20 mA	Yes; 15 bit
• -20 to +20 mA	Yes; 16 bit incl. sign
• 4 to 20 mA	Yes; 14 bit
Connection of actuators	
• for voltage output 2-conductor connection	Yes
• for voltage output 4-conductor connection	Yes
• for current output 2-conductor connection	Yes
Load impedance (in rated range of output)	
• with voltage outputs, min.	2 kΩ
• with voltage outputs, capacitive load, max.	1 μF
• with current outputs, max.	500 Ω
• with current outputs, inductive load, max.	1 mH

6ES7 135-6HD00-0BA1 AQ 4xU/I ST	
Cable length	
• Cable length, shielded, max.	200 m
Analog value creation	
Settling time	
• for resistive load	0.1 ms
• for capacitive load	1 ms
• for inductive load	0.5 ms
Interrupts/diagnostics/ status information	
Substitute values connectable	Yes
Alarms	
• Diagnostic alarm	Yes
Diagnostic messages	
• Diagnostics	Yes
• Monitoring the supply voltage	Yes
• Wire break	Yes
• Short circuit	Yes
• Overflow/underflow	Yes
Diagnostics indication LED	
• Monitoring the supply voltage	Yes; Green LED
• Channel status display	Yes; Green LED
• for module diagnostics	Yes; Green/red LED
Galvanic isolation	
Electrical isolation channels	
• between the channels and the backplane bus	Yes
Isolation	
Isolation checked with	707 V DC (type test)

Technical specifications (continued)

6ES7 135-6HD00-0BA1 AQ 4xU/I ST		6ES7 135-6HD00-0BA1 AQ 4xU/I ST	
Ambient conditions		Dimensions	
Operating temperature		Width	15 mm
• horizontal installation, min.	0 °C	Weight	31 g
• horizontal installation, max.	60 °C		
• vertical installation, min.	0 °C	Weight, approx.	
• vertical installation, max.	50 °C		

Ordering data

Order No.	Order No.	Order No.
Analog output modules AQ 4XU/I Standard, BU type A0 or A1, color code CC00	6ES7 135-6HD00-0BA1	BU15-P16+A0+12D/T BU type A1; BaseUnit (light) with 16 process terminals (1 ... 16) on the module and an additional 2x5 internally jumpered AUX terminals (1 B to 5 B and 1 C to 5 C); for starting a new load group (max. 10 A)
Usable type A0 BaseUnits	6ES7 193-6BP00-0DA0	6ES7 193-6BP40-0DA1
BU15-P16+A0+2D BU type A0; BaseUnit (light) with 16 process terminals to the module; for starting a new load group (max. 10 A)	6ES7 193-6BP00-0BA0	BU15-P16+A0+12B/T BU type A1; BaseUnit (dark) with 16 process terminals (1 ... 16) on the module and an additional 2x5 internally jumpered AUX terminals (1 B to 5 B and 1 C to 5 C); for starting a new load group
BU15-P16+A0+2B BU type A0; BaseUnit (dark) with 16 process terminals to the module; for continuing the load group	6ES7 193-6BP00-0BA0	Accessories
BU15-P16+A10+2D BU type A0; BaseUnit (light) with 16 process terminals (1 ... 16) on the module and an additional 10 internally jumpered AUX terminals (1 A to 10 A); for starting a new load group (max. 10 A)	6ES7 193-6BP20-0DA0	Reference identification label 10 sheets of 16 labels
BU15-P16+A10+2B BU type A0; BaseUnit (dark) with 16 process terminals (1 ... 16) on the module and an additional 10 internally jumpered AUX terminals (1 A to 10 A); for continuing the load group	6ES7 193-6BP20-0BA0	Labeling strips 1 roll of 500 strips
Usable Type A1 BaseUnits (temperature detection)		BU cover, 15 mm for covering empty slots (gaps); 5 units
BU15-P16+A0+2D/T BU type A1; BaseUnit (light) with 16 process terminals to the module; for starting a new load group (max. 10 A)	6ES7 193-6BP00-0DA1	Shield connection 5 shield supports and 5 shield terminals
BU15-P16+A0+2B/T BU type A1; BaseUnit (dark) with 16 process terminals to the module; for continuing the load group	6ES7 193-6BP00-0BA1	Color-coding plates
		• Color code CC71, for 10 AUX terminals, for BU type A0, with push-in terminals; 10 units
		• Color code CC72, for 10 AUX terminals, for BU type A0, with push-in terminals; 10 units
		• Color code CC73, for 10 AUX terminals, for BU type A0, with push-in terminals; 10 units
		• Color code CC74, for 2x5 additional terminals, for BU type A1, with push-in terminals; 10 units
		6ES7 193-6CP71-2AA0
		6ES7 193-6CP72-2AA0
		6ES7 193-6CP73-2AA0
		6ES7 193-6CP74-2AA0

SIMATIC ET 200 distributed I/O

ET 200SP

SIPLUS analog input modules

Overview



- 4-channel analog input modules for the ET 200SP
- Can be plugged into type A0 or A1 BaseUnits (BU) with automatic coding

- LED display for error, operation, supply voltage and status
- Clear labeling on front of module
 - Plain text identification of the module type and function class
 - 2D matrix code (order and serial number)
 - Connection diagram
 - Color coding of the module type AI: Light blue
 - Hardware and firmware version
 - Color code CC for module-specific color coding of the potentials at the terminals of the BU
 - Complete order number
- Optional labeling accessories
 - Labeling strips
 - Reference identification label
- Optional module-specific color identification of the terminals according to the color code CC

Note:

SIPLUS extreme products are based on Siemens Industry standard products. The contents listed here were taken from the respective standard products. SIPLUS extreme specific information was added.

Technical specifications

The technical data correspond to those of the based-on modules apart from the values listed in the table.

	6AG1 134-6HD00-7BA1 AI 4xU/I 2-wire ST	6AG1 134-6GD00-7BA1 AI 4xI 2-/4-wire ST	6AG1 134-6JD00-2CA1 AI 4xRTD/TC 2-/3-/4-wire HF
Based on	6ES7 134-6HD00-0BA1	6ES7 134-6GD00-0BA1	6ES7 134-6JD00-0CA1
Ambient conditions			
Operating temperature			
• Min.	-40 °C; = Tmin	-40 °C; = Tmin	
• max.	70 °C; = Tmax	70 °C; = Tmax	
• horizontal installation, min.	-40 °C; = Tmin	-40 °C; = Tmin	-40 °C
• horizontal installation, max.	70 °C; = Tmax; > 60 °C max. 1x +/- 20 mA or 4x +/- 10 V permissible	70 °C; = Tmax; > 60 °C max. 1x +/- 20 mA permissible	60 °C
• vertical installation, min.	-40 °C; = Tmin	-40 °C; = Tmin	-40 °C
• vertical installation, max.	50 °C; = Tmax	50 °C; = Tmax	50 °C
Extended ambient conditions			
• Relative humidity			
- With condensation/maximum/tested in accordance with IEC 60068-2-38	100 %; RH incl. condensation/frost (no commissioning under condensation conditions)	100 %; RH incl. condensation/frost (no commissioning under condensation conditions)	100 %; RH incl. condensation/frost (no commissioning under condensation conditions)
• Resistance			
- to biologically active substances	Yes; Class 3B2 mold, fungus and dry rot spores (with the exception of fauna). The supplied connector covers must remain on the unused interfaces during operation!	Yes; Class 3B2 mold, fungus and dry rot spores (with the exception of fauna). The supplied connector covers must remain on the unused interfaces during operation!	Yes; Class 3B2 mold, fungus and dry rot spores (with the exception of fauna). The supplied connector covers must remain on the unused interfaces during operation!
- to chemically active substances	Yes; Class 3C4 (RH < 75%) incl. salt spray according to EN 60068-2-52 (degree of severity 3). The supplied connector covers must remain on the unused interfaces during operation!	Yes; Class 3C4 (RH < 75%) incl. salt spray according to EN 60068-2-52 (degree of severity 3). The supplied connector covers must remain on the unused interfaces during operation!	Yes; Class 3C4 (RH < 75%) incl. salt spray according to EN 60068-2-52 (degree of severity 3). The supplied connector covers must remain on the unused interfaces during operation!
- to mechanically active substances	Yes; Class 3S4 incl. sand, dust. The supplied connector covers must remain on the unused interfaces during operation!	Yes; Class 3S4 incl. sand, dust. The supplied connector covers must remain on the unused interfaces during operation!	Yes; Class 3S4 incl. sand, dust. The supplied connector covers must remain on the unused interfaces during operation!

Ordering data	Order No.	Order No.
<p>SIPLUS analog input modules</p> <p>(Extended temperature range and medial exposure)</p> <p>AI 4XU/I 2-wire Standard BU type A0 or A1, color code CC03</p> <p>AI 4xI 2-, 4-wire Standard, BU type A0 or A1, color code CC03</p> <p>AI 4xRTD/TC 2-, 3-, 4-wire High Feature BU type A0 or A1, color code CC00</p>	<p>6AG1 134-6HD00-7BA1</p> <p>6AG1 134-6GD00-7BA1</p> <p>6AG1 134-6JD00-2CA1</p>	<p>Usable SIPLUS BaseUnits type A1 (temperature detection)</p> <p>BU15-P16+A0+2D/T</p> <p>(Extended temperature range and medial exposure)</p> <p>BU type A1; BaseUnit (light) with 16 process terminals to the module; for starting a new load group (max. 10 A)</p> <p>6AG1 193-6BP00-7DA1</p>
<p>Usable SIPLUS BaseUnits type A0</p> <p>BU15-P16+A0+2D</p> <p>(Extended temperature range and medial exposure)</p> <p>BU type A0; BaseUnit (light) with 16 process terminals to the module; for starting a new load group (max. 10 A)</p>	<p>6AG1 193-6BP00-7DA0</p>	<p>BU15-P16+A0+2B/T</p> <p>(Extended temperature range and medial exposure)</p> <p>BU type A1; BaseUnit (dark) with 16 process terminals to the module; for continuing the load group</p> <p>6AG1 193-6BP00-7BA1</p>
<p>BU15-P16+A0+2B</p> <p>(Extended temperature range and medial exposure)</p> <p>BU type A0; BaseUnit (dark) with 16 process terminals to the module; for continuing the load group</p>	<p>6AG1 193-6BP00-7BA0</p>	<p>BU15-P16+A0+12D/T</p> <p>(Extended temperature range and medial exposure)</p> <p>BU type A1; BaseUnit (light) with 16 process terminals (1 ... 16) on the module and an additional 2x5 internally jumpered AUX terminals (1 B to 5 B and 1 C to 5 C); for starting a new load group (max. 10 A)</p> <p>6AG1 193-6BP40-7DA1</p>
<p>BU15-P16+A10+2D</p> <p>(Extended temperature range and medial exposure)</p> <p>BU type A0; BaseUnit (light) with 16 process terminals (1 ... 16) on the module and an additional 10 internally jumpered AUX terminals (1 A to 10 A); for starting a new load group (max. 10 A)</p>	<p>6AG1 193-6BP20-7DA0</p>	<p>BU15-P16+A0+12B/T</p> <p>(Extended temperature range and medial exposure)</p> <p>BU type A1; BaseUnit (dark) with 16 process terminals (1 ... 16) on the module and an additional 2x5 internally jumpered AUX terminals (1 B to 5 B and 1 C to 5 C); for starting a new load group</p> <p>6AG1 193-6BP40-7BA1</p>
<p>BU15-P16+A10+2B</p> <p>(Extended temperature range and medial exposure)</p> <p>BU type A0; BaseUnit (dark) with 16 process terminals (1 ... 16) on the module and an additional 10 internally jumpered AUX terminals (1 A to 10 A); for continuing the load group</p>	<p>6AG1 193-6BP20-7BA0</p>	<p>Accessories</p> <p>See SIMATIC ET 200SP, analog input modules, page 9/21</p>

SIMATIC ET 200 distributed I/O

ET 200SP

SIPLUS analog output modules

Overview



- 4-channel analog input modules for the ET 200SP
- Can be plugged into Type A0 or A1 BaseUnits (BU) with automatic coding
- LED display for error, operation, supply voltage and status
- Clear labeling on front of module
 - Plain text identification of the module type and function class
 - 2D matrix code (order and serial number)
 - Connection diagram
 - Color coding of the module type AQ: dark blue
 - Hardware and firmware version
 - Color code CC for module-specific color coding of the potentials at the terminals of the BU
 - Complete order number
- Optional labeling accessories
 - Labeling strips
 - Reference identification label
- Optional module-specific color identification of the terminals according to the color code CC

Note:

SIPLUS extreme products are based on Siemens Industry standard products. The contents listed here were taken from the respective standard products. SIPLUS extreme specific information was added.

Technical specifications

The technical data correspond to those of the based-on modules apart from the values listed in the table.

Based on	6AG1 135-6HD00-7BA1 AQ 4xU/I ST 6ES7 135-6HD00-0BA1
Ambient conditions	
Operating temperature	
• Min.	-40 °C; = Tmin
• max.	70 °C; = Tmax
• horizontal installation, min.	-40 °C; = Tmin
• horizontal installation, max.	70 °C; = Tmax; > +60 °C max. 2x +/- 10 V permissible
• vertical installation, min.	-40 °C; = Tmin
• vertical installation, max.	50 °C; = Tmax
Extended ambient conditions	
• Relative to ambient temperature-atmospheric pressure-installation altitude	Tmin ... Tmax at 1080 hPa ... 795 hPa (-1000 m ... +2000 m) // Tmin ... (Tmax - 10K) at 795 hPa ... 658 hPa (+2000 m ... +3500 m) // Tmin ... (Tmax - 20K) at 658 hPa ... 540 hPa (+3500 m ... +5000 m)
• Relative humidity	100 %; RH incl. condensation/frost (no commissioning under condensation conditions)
- With condensation/maximum/ tested in accordance with IEC 60068-2-38	
• Resistance	Yes; Class 3B2 mold, fungus and dry rot spores (with the exception of fauna). The supplied connector covers must remain on the unused interfaces during operation!
- to biologically active substances	Yes; Class 3C4 (RH < 75%) incl. salt spray according to EN 60068-2-52 (degree of severity 3). The supplied connector covers must remain on the unused interfaces during operation!
- to chemically active substances	Yes; Class 3S4 incl. sand, dust. The supplied connector covers must remain on the unused interfaces during operation!
- to mechanically active substances	

Ordering data	Order No.	Order No.
SIPLUS analog output modules (Extended temperature range and medial exposure) AQ 4XU/I Standard, BU type A0 or A1, color code CC03	6AG1 135-6HD00-7BA1	
Usable SIPLUS BaseUnits type A0 BU15-P16+A0+2D (Extended temperature range and medial exposure) BU type A0; BaseUnit (light) with 16 process terminals to the module; for starting a new load group (max. 10 A)	6AG1 193-6BP00-7DA0	Usable SIPLUS BaseUnits type A1 (temperature detection) BU15-P16+A0+2D/T (Extended temperature range and medial exposure) BU type A1; BaseUnit (light) with 16 process terminals to the module; for starting a new load group (max. 10 A)
BU15-P16+A0+2B (Extended temperature range and medial exposure) BU type A0; BaseUnit (dark) with 16 process terminals to the module; for continuing the load group	6AG1 193-6BP00-7BA0	BU15-P16+A0+2B/T (Extended temperature range and medial exposure) BU type A1; BaseUnit (dark) with 16 process terminals to the module; for continuing the load group
BU15-P16+A10+2D (Extended temperature range and medial exposure) BU type A0; BaseUnit (light) with 16 process terminals (1 ... 16) on the module and an additional 10 internally jumpered AUX terminals (1 A to 10 A); for starting a new load group (max. 10 A)	6AG1 193-6BP20-7DA0	BU15-P16+A0+12D/T (Extended temperature range and medial exposure) BU type A1; BaseUnit (light) with 16 process terminals (1 ... 16) on the module and an additional 2x5 internally jumpered AUX terminals (1 B to 5 B and 1 C to 5 C); for starting a new load group (max. 10 A)
BU15-P16+A10+2B (Extended temperature range and medial exposure) BU type A0; BaseUnit (dark) with 16 process terminals (1 ... 16) on the module and an additional 10 internally jumpered AUX terminals (1 A to 10 A); for continuing the load group	6AG1 193-6BP20-7BA0	BU15-P16+A0+12B/T (Extended temperature range and medial exposure) BU type A1; BaseUnit (dark) with 16 process terminals (1 ... 16) on the module and an additional 2x5 internally jumpered AUX terminals (1 B to 5 B and 1 C to 5 C); for starting a new load group
		Accessories See SIMATIC ET 200SP, analog output modules, page 9/23

SIMATIC ET 200 distributed I/O

ET 200SP

Communication CM PtP serial interface

Overview



- CM PtP communication module; module for serial communication connections with RS232 and RS422 interfaces. RS485 for the Freeport, 3964(R), Modbus RTU and USS protocols, max. 115.2 kbit/s, 2 KB frame length, 4 KB receive buffer.

- Protocols supported
 - Freeport: User-parameterizable frame format for universal communication
 - 3964(R) for improved transmission reliability
 - Modbus RTU master (requires instructions in SIMATIC S7)
 - Modbus RTU slave (requires instructions in SIMATIC S7)
 - USS, implemented through instructions
- Interface properties
 - RS232 with auxiliary signals
 - RS422 for full-duplex connections
 - RS485 for half-duplex and multi-point connections
 - Transmission rates from 300 to 115200 bit/s
- Can be plugged into Type A0 BaseUnits (BU) with automatic coding
- LED display for errors, operation, and supply voltage
- Communication display for sending and receiving
- Clear labeling on front of module
 - Plain text identification of the module type and function class
 - 2D matrix code (order and serial number)
 - Connection diagram
 - Color coding of the CM module type: Silver
 - Hardware and firmware version
 - Complete order number
- Optional labeling accessories
 - Labeling strips
 - Reference identification label

Technical specifications

	6ES7 137-6AA00-0BA0 ET 200SP CM PtP
General information	
Product function	
• I&M data	Yes; I&M 0
Engineering with	
• STEP 7 TIA Portal can be configured/integrated as of version	V12.0 / V12.0
• STEP 7 can be configured/integrated as of version	V5.5 SP2 with GSD file
• PROFIBUS as of GSD version/GSD revision	- / -
• PROFINET as of GSD version/GSD revision	V2.3
Design/mounting	
Rail-mounting possible	Yes; standard mounting rail
Supply voltage	
Type of supply voltage	24 V DC
Rated value (DC)	24 V
Permissible range, lower limit (DC)	19.2 V
Permissible range, upper limit (DC)	28.8 V
Reverse polarity protection	Yes
Input current	
Current consumption (rated value)	29 mA
Power loss	
Power loss, typ.	0.7 W
Interfaces	
1. Interface	
• Interface (physical)	
- RS 232	Yes
- RS 422	Yes
- RS 485	Yes

	6ES7 137-6AA00-0BA0 ET 200SP CM PtP
Interface (physical)	
RS 232	
• Data transfer rate, max.	115.2 kbit/s
• Max. cable length	15 m
• RS-232 auxiliary signals	RTS, CTS, DTR, DSR, RI, DCD
RS 485	
• Data transfer rate, max.	115.2 kbit/s
• Max. cable length	1 200 m
RS 422	
• Maximum	115.2 kbit/s
• Max. cable length	1 200 m
• 4-wire full duplex connection	Yes
• 4-wire full multipoint connection	Yes
Protocols	
Integrated protocols	
• Freeport	
- Frame length, max.	2 KB
- Bits per character	7 or 8
- Number of stop bits	1 or 2 bits
- Parity	none, even, odd, always 1, always 0, any
• 3964 (R)	
- Frame length, max.	2 KB
- Number of bits per character	7 or 8
- Number of stop bits	1 or 2 bits
- Parity	none, even, odd, always 1, always 0, any
• Modbus RTU master	
- Address range	1 to 247, extended 1 to 65535
- Number of slaves, max.	32
• Modbus RTU slave	
- Address range	1 to 247, extended 1 to 65535
Frame buffer	
• Buffer memory for frames	4 KB
• Number of frames that can be buffered	255

Technical specifications (continued)

6ES7 137-6AA00-0BA0 ET 200SP CM PtP	
Interrupts/diagnostics/ status information	
Interrupts	
• Diagnostic interrupt	Yes
• Hardware interrupt	No
Diagnostic messages	
• Diagnostics	Yes
• Wire break	Yes
Diagnostics indicator LED	
• Monitoring of supply voltage	Yes; green PWR-LED
• for module diagnostics	Yes; green/red DIAG-LED
• Receive RxD	Yes; green LED
• Send TxD	Yes; green LED
Electrical isolation between backplane bus and interface	Yes
Permissible potential difference between different circuits	75 V DC/60 V AC (basic insulation)
Insulation Insulation tested with	707 V DC (type test)

6ES7 137-6AA00-0BA0 ET 200SP CM PtP	
Environmental conditions	
Operating temperature	
• Horizontal installation position, min.	0 °C
• Horizontal installation position, max.	60 °C
• Vertical installation position, min.	0 °C
• Vertical installation position, max.	50 °C
Distributed operation	
On SIMATIC S7-300	Yes
On SIMATIC S7-400	Yes
On SIMATIC S7-1200	No
On SIMATIC S7-1500	Yes
On standard PROFINET controller	Yes
Dimensions	
Width	15 mm
Height	73 mm
Depth	58 mm
Weights	
Weight, approx.	30 g

Ordering data

Ordering data	Order No.
CM PtP communication module for serial communication connections with RS232 and RS422 interfaces. RS485	6ES7 137-6AA00-0BA0
Accessories	
BU15-P16+A0+2D BU type A0; BaseUnit (light) with 16 process terminals to the module; for starting a new load group (max. 10 A)	6ES7 193-6BP00-0DA0
BU15-P16+A0+2B BU type A0; BaseUnit (dark) with 16 process terminals to the module; for continuing the load group	6ES7 193-6BP00-0BA0
BU15-P16+A10+2D BU type A0; BaseUnit (light) with 16 process terminals (1 ... 16) on the module and an additional 10 internally jumpered AUX terminals (1A to 10A); for starting a new load group (max. 10 A)	6ES7 193-6BP20-0DA0

Ordering data	Order No.
BU15-P16+A10+2B BU type A0; BaseUnit (dark) with 16 process terminals (1 ... 16) on the module and an additional 10 internally jumpered AUX terminals (1A to 10A); for continuing the load group	6ES7 193-6BP20-0BA0
Reference identification label 10 sheets of 16 labels	6ES7 193-6LF30-0AW0
Labeling strips Light gray. Roll with 500 units.	6ES7 193-6LR10-0AA0
Shield connection 5 shield supports and 5 shield terminals, for direct connection	6ES7 193-6SC00-1AM0

SIMATIC ET 200 distributed I/O

ET 200SP

Communication CM IO-Link

Overview

- CM IO-Link communication module
Serial communication module for connecting up to 4 IO-Link devices in accordance with IO Link specification V1.0 and V1.1. The IO-Link parameters are configured using the Port Configuration Tool (PCT), Version V3.0 and higher.
- Supported data transfer rates
 - COM1 (4.8 kbit/s)
 - COM2 (38.4 kbit/s)
 - COM3 (230.4 kbit/s)
- Expansion limits
 - Length of cable: Max. 20 m
 - Max. 32 bytes of input and output data per port
 - Max. 32 bytes of input and output data per module
- Supported ET 200SP system functions
 - Replacement without PG with automatic backup without the engineering tool of the IO Link Device Parameter (V1.1 devices only) and the IO-Link master parameters by means of redundant saving of parameters to e-coding element
 - Reparameterization during operation
 - Identification data I&M
 - Firmware update
 - PROFlenergy
- Can be plugged into Type A0 BaseUnits (BU) with automatic e-coding
- LED indicators
 - DIAG: Operating state indicator (green/red) of the module
 - C1..C4: Port status indicator (green) for Port 1, 2, 3 and 4
 - Q1..Q4: Channel status indicator (green) for Port 1, 2, 3 and 4
 - F1..F4: Port fault indicator (red) for Port 1, 2, 3 and 4
 - PWR: Supply voltage indicator (green)
- Clear labeling on front of module
 - Plain text identification of the module type and function class
 - 2D matrix code (order and serial number)
 - Connection diagram
 - Color-coding of the module class CM: Silver
 - Hardware and firmware version
 - Complete order number
- Optional accessories
 - Labeling strips
 - Reference identification label
 - Color-coding plate with color code CC04

Technical specifications

6ES7 137-6BD00-0BA0 ET 200SP, CM IO-Link	
Supply voltage	
Type of supply voltage	24 V DC
Rated value (DC)	24 V
Reverse polarity protection	Yes
Input current	
Current consumption, max.	45 mA; without load
Power loss	
Power loss, typ.	1 W
Interrupts/diagnostics/ status information	
Interrupts	
• Diagnostic interrupt	Yes; port diagnostics only available in IO-Link mode.
Diagnostic messages	
• Diagnostics	Yes
• Monitoring of supply voltage	Yes
• Short-circuit	Yes
• Group error	Yes
Diagnostics indicator LED	
• Monitoring of supply voltage	Yes; green PWR-LED
• Channel status indicator	Yes; one green LED per channel for channel status Qn (SIO mode) and PORT status Cn (IO-Link mode)
• for channel diagnostics	Yes; red Fn LED
• for module diagnostics	Yes; green/red DIAG-LED

6ES7 137-6BD00-0BA0 ET 200SP, CM IO-Link	
Electrical isolation	
Galvanic isolation of channels	
• between the channels	No
• between the channels and the back-plane bus	Yes
Permissible potential difference	
between different circuits	75 V DC / 60 V AC (basic insulation)
Insulation	
Insulation tested with	707 V DC (type test)
Environmental conditions	
Operating temperature	
• min.	0 °C
• Max.	60 °C
• Horizontal installation position, min.	0 °C
• Horizontal installation position, max.	60 °C
• Vertical installation position, min.	0 °C
• Vertical installation position, max.	50 °C
Dimensions	
Width	15 mm
Weights	
Weight, approx.	30 g

Ordering data	Order No.	Order No.
CM IO-Link communication module Serial communication module for connecting up to 4 IO-Link devices	6ES7 137-6BD00-0BA0	
Accessories BU15-P16+A0+2D BU type A0; BaseUnit (light) with 16 process terminals to the module; for starting a new load group (max. 10 A)	6ES7 193-6BP00-0DA0	
BU15-P16+A0+2B BU type A0; BaseUnit (dark) with 16 process terminals to the module; for continuing the load group	6ES7 193-6BP00-0BA0	
BU15-P16+A10+2D BU type A0; BaseUnit (light) with 16 process terminals (1 ... 16) on the module and an additional 10 internally jumpered AUX terminals (1 A to 10 A); for starting a new load group (max. 10 A)	6ES7 193-6BP20-0DA0	
		BU15-P16+A10+2B BU type A0; BaseUnit (dark) with 16 process terminals (1 ... 16) on the module and an additional 10 internally jumpered AUX terminals (1 A to 10 A); for continuing the load group
		Reference identification label 10 sheets of 16 labels
		Labeling strips Light gray. Roll with 500 units.
		Color-coding plates Color code CC04, module-specific, for 16 push-in terminals; 10 units
		6ES7 193-6LF30-0AW0
		6ES7 193-6LR10-0AA0
		6ES7 193-6CP04-2MA0

SIMATIC ET 200 distributed I/O

ET 200SP

BaseUnits

Overview



With the BaseUnits, the ET 200SP offers a rugged and service-friendly design with permanent wiring:

- No tools needed for one-handed wiring using push-in terminals
- Outstanding access due to arrangement of measuring tap, spring NC contacts and cable entry in columns, while at the same time reducing the space required by 64%
- Fault-proof color coding of the spring NC contacts for better orientation in the terminal panel
- Replacement of I/O modules during operation without affecting the wiring
- Operation with module gaps (missing I/O module)
- Automatic coding of the I/O modules prevents destruction of the electronics if a module is accidentally inserted in the wrong slot during replacement
- High immunity to electromagnetic interference due to
 - self-assembling shielded backplane bus,
 - multi-layer conductor plate with shield levels for interference-free signal transmission from the terminal to the I/O module,
 - system-integrated, space-saving shield connection for quick installation.
- Self-assembling potential groups without external wiring or jumpers
- Replaceable terminal box
- Side-by-side latching of the BUs for high mechanical load capacity
- Optional module-specific color identification of the terminals according to the color code CC
- Actuation of the spring NC contacts with a standard screwdriver, with a blade width up to 3.5 mm

Technical specifications

	6ES7 193-6BP00-0DA0 BU15-P16+A0+2D	6ES7 193-6BP00-0BA0 BU15-P16+A0+2B	6ES7 193-6BP20-0DA0 BU15-P16+A10+2D	6ES7 193-6BP20-0BA0 BU15-P16+A10+2B
Dimensions				
Width	15 mm	15 mm	15 mm	15 mm
Height	117 mm	117 mm	141 mm	141 mm
Weight				
Weight, approx.	40 g	40 g	50 g	50 g
	6ES7 193-6BP00-0DA1 BU15-P16+A0+2D/T	6ES7 193-6BP00-0BA1 BU15-P16+A0+2B/T	6ES7 193-6BP40-0DA1 BU15-P16+A0+12D/T	6ES7 193-6BP40-0BA1 BU15-P16+A0+12B/T
Dimensions				
Width	15 mm	15 mm	15 mm	15 mm
Height	117 mm	117 mm	141 mm	141 mm
Weight				
Weight, approx.	40 g	40 g	50 g	50 g

Ordering data	Order No.	Order No.
Type A0 BaseUnits		Accessories
BU15-P16+A0+2D BU type A0; BaseUnit (light) with 16 process terminals to the module; for starting a new load group (max. 10 A)	6ES7 193-6BP00-0DA0	Reference identification label 10 sheets of 16 labels 6ES7 193-6LF30-0AW0
BU15-P16+A0+2B BU type A0; BaseUnit (dark) with 16 process terminals to the module; for continuing the load group	6ES7 193-6BP00-0BA0	BU cover, 15 mm for covering empty slots (gaps); 5 units 6ES7 133-6CV15-1AM0
BU15-P16+A10+2D BU type A0; BaseUnit (light) with 16 process terminals (1 ... 16) on the module and an additional 10 internally jumpered AUX terminals (1A to 10A); for starting a new load group (max. 10 A)	6ES7 193-6BP20-0DA0	Shield connection 5 shield supports and 5 shield terminals 6ES7 193-6SC00-1AM0
BU15-P16+A10+2B BU type A0; BaseUnit (dark) with 16 process terminals (1 ... 16) on the module and an additional 10 internally jumpered AUX terminals (1A to 10A); for continuing the load group	6ES7 193-6BP20-0BA0	Color-coding plates • Color code CC01, module-specific, for 16 push-in terminals; 10 units 6ES7 193-6CP01-2MA0 • Color code CC02, module-specific, for 16 push-in terminals; 10 units 6ES7 193-6CP02-2MA0 • Color code CC03, module-specific, for 16 push-in terminals; 10 units 6ES7 193-6CP03-2MA0 • Color code CC04, module-specific, for 16 push-in terminals; 10 units 6ES7 193-6CP04-2MA0 • Color code CC71, for 10 AUX terminals, for BU type A0, with push-in terminals; 10 units 6ES7 193-6CP71-2AA0 • Color code CC72, for 10 AUX terminals, for BU type A0, with push-in terminals; 10 units 6ES7 193-6CP72-2AA0 • Color code CC73, for 10 AUX terminals, for BU type A0, with push-in terminals; 10 units 6ES7 193-6CP73-2AA0
Type B0 BaseUnits		
BU20-P12+A4+0B BU type B0; BaseUnit (dark) with 12 process terminals (1 ... 12) on the module and an additional 4 internally jumpered AUX terminals (1A to 4A); for continuing the load group	6ES7 193-6BP20-0BB0	
Type A1 BaseUnits (with temperature detection)		
BU15-P16+A0+2D/T BU type A1; BaseUnit (light) with 16 process terminals to the module; for starting a new load group (max. 10 A)	6ES7 193-6BP00-0DA1	
BU15-P16+A0+2B/T BU type A1; BaseUnit (dark) with 16 process terminals to the module; for continuing the load group	6ES7 193-6BP00-0BA1	
BU15-P16+A0+12D/T BU type A1; BaseUnit (light) with 16 process terminals (1 ... 16) on the module and an additional 2x5 internally jumpered AUX terminals (1 B to 5 B and 1 C to 5 C); for starting a new load group (max. 10 A)	6ES7 193-6BP40-0DA1	
BU15-P16+A0+12B/T BU type A1; BaseUnit (dark) with 16 process terminals (1 ... 16) on the module and an additional 2x5 internally jumpered AUX terminals (1 B to 5 B and 1 C to 5 C); for starting a new load group	6ES7 193-6BP40-0BA1	

SIMATIC ET 200 distributed I/O

ET 200SP

SIPLUS BaseUnits

Overview



With the BaseUnits, the ET 200SP offers a rugged and service-friendly design with permanent wiring:

- No tools needed for one-handed wiring using push-in terminals
- Outstanding access due to arrangement of measuring tap, spring NC contacts and cable entry in columns, while at the same time reducing the space required by 64%
- Fault-proof color coding of the spring NC contacts for better orientation in the terminal panel
- Replacement of I/O modules during operation without affecting the wiring

- Operation with module gaps (missing I/O module)
- Automatic coding of the I/O modules prevents destruction of the electronics if a module is accidentally inserted in the wrong slot during replacement
- High immunity to electromagnetic interference due to
 - self-assembling shielded backplane bus,
 - multi-layer conductor plate with shield levels for interference-free signal transmission from the terminal to the I/O module,
 - system-integrated, space-saving shield connection for quick installation.
- Self-assembling potential groups without external wiring or jumpers
- Replaceable terminal box
- Side-by-side latching of the BUs for high mechanical load capacity
- Optional module-specific color identification of the terminals according to the color code CC
- Actuation of the spring NC contacts with a standard screwdriver, with a blade width up to 3.5 mm

Note:

SIPLUS extreme products are based on Siemens Industry standard products. The contents listed here were taken from the respective standard products. SIPLUS extreme specific information was added.

Technical specifications

The technical data correspond to those of the based-on modules apart from the values listed in the table.

	6AG1 193-6BP00-7BA0 BU15-P16+A0+2B	6AG1 193-6BP00-7DA0 BU15-P16+A0+2D	6AG1 193-6BP20-7BA0 BU15-P16+A10+2B	6AG1 193-6BP20-7DA0 BU15-P16+A10+2D
Based on	6ES7 193-6BP00-0BA0	6ES7 193-6BP00-0DA0	6ES7 193-6BP20-0BA0	6ES7 193-6BP20-0DA0
Ambient conditions				
Operating temperature				
• Min.	-40 °C	-40 °C	-40 °C	-40 °C
• max.	70 °C	70 °C	70 °C	70 °C
Extended ambient conditions				
• Relative to ambient temperature-atmospheric pressure-installation altitude	Tmin ... Tmax at 1080 hPa ... 795 hPa (-1000 m ... +2000 m) // Tmin ... (Tmax - 10K) at 795 hPa ... 658 hPa (+2000 m ... +3500 m) // Tmin ... (Tmax - 20K) at 658 hPa ... 540 hPa (+3500 m ... +5000 m)	Tmin ... Tmax at 1080 hPa ... 795 hPa (-1000 m ... +2000 m) // Tmin ... (Tmax - 10K) at 795 hPa ... 658 hPa (+2000 m ... +3500 m) // Tmin ... (Tmax - 20K) at 658 hPa ... 540 hPa (+3500 m ... +5000 m)	Tmin ... Tmax at 1080 hPa ... 795 hPa (-1000 m ... +2000 m) // Tmin ... (Tmax - 10K) at 795 hPa ... 658 hPa (+2000 m ... +3500 m) // Tmin ... (Tmax - 20K) at 658 hPa ... 540 hPa (+3500 m ... +5000 m)	Tmin ... Tmax at 1080 hPa ... 795 hPa (-1000 m ... +2000 m) // Tmin ... (Tmax - 10K) at 795 hPa ... 658 hPa (+2000 m ... +3500 m) // Tmin ... (Tmax - 20K) at 658 hPa ... 540 hPa (+3500 m ... +5000 m)
• Relative humidity				
- With condensation/maximum/ tested in accordance with IEC 60068-2-38	100 %; RH incl. condensation/ frost (no commissioning under condensation conditions)	100 %; RH incl. condensation/ frost (no commissioning under condensation conditions)	100 %; RH incl. condensation/ frost (no commissioning under condensation conditions)	100 %; RH incl. condensation/ frost (no commissioning under condensation conditions)
• Resistance				
- to biologically active substances	Yes; Class 3B2 mold, fungus and dry rot spores (with the exception of fauna). The supplied connector covers must remain on the unused interfaces during operation!	Yes; Class 3B2 mold, fungus and dry rot spores (with the exception of fauna). The supplied connector covers must remain on the unused interfaces during operation!	Yes; Class 3B2 mold, fungus and dry rot spores (with the exception of fauna). The supplied connector covers must remain on the unused interfaces during operation!	Yes; Class 3B2 mold, fungus and dry rot spores (with the exception of fauna). The supplied connector covers must remain on the unused interfaces during operation!

Technical specifications (continued)

	6AG1 193-6BP00-7BA0 BU15-P16+A0+2B	6AG1 193-6BP00-7DA0 BU15-P16+A0+2D	6AG1 193-6BP20-7BA0 BU15-P16+A10+2B	6AG1 193-6BP20-7DA0 BU15-P16+A10+2D
Based on	6ES7 193-6BP00-0BA0	6ES7 193-6BP00-0DA0	6ES7 193-6BP20-0BA0	6ES7 193-6BP20-0DA0
<ul style="list-style-type: none"> Resistance - to chemically active substances - to mechanically active substances 	<p>Yes; Class 3C4 (RH < 75%) incl. salt spray according to EN 60068-2-52 (degree of severity 3). The supplied connector covers must remain on the unused interfaces during operation!</p> <p>Yes; Class 3S4 incl. sand, dust. The supplied connector covers must remain on the unused interfaces during operation!</p>	<p>Yes; Class 3C4 (RH < 75%) incl. salt spray according to EN 60068-2-52 (degree of severity 3). The supplied connector covers must remain on the unused interfaces during operation!</p> <p>Yes; Class 3S4 incl. sand, dust. The supplied connector covers must remain on the unused interfaces during operation!</p>	<p>Yes; Class 3C4 (RH < 75%) incl. salt spray according to EN 60068-2-52 (degree of severity 3). The supplied connector covers must remain on the unused interfaces during operation!</p> <p>Yes; Class 3S4 incl. sand, dust. The supplied connector covers must remain on the unused interfaces during operation!</p>	<p>Yes; Class 3C4 (RH < 75%) incl. salt spray according to EN 60068-2-52 (degree of severity 3). The supplied connector covers must remain on the unused interfaces during operation!</p> <p>Yes; Class 3S4 incl. sand, dust. The supplied connector covers must remain on the unused interfaces during operation!</p>
	6AG1 193-6BP00-7BA1 BU15-P16+A0+2B/T	6AG1 193-6BP00-7DA1 BU15-P16+A0+2D/T	6AG1 193-6BP40-7BA1 BU15-P16+A0+12B/T	6AG1 193-6BP40-7DA1 BU15-P16+A0+12D/T
Based on	6ES7 193-6BP00-0BA1	6ES7 193-6BP00-0DA1	6ES7 193-6BP40-0BA1	6ES7 193-6BP40-0DA1
Ambient conditions				
Operating temperature				
<ul style="list-style-type: none"> Min. max. 	-40 °C 70 °C	-40 °C 70 °C	-40 °C 70 °C	-40 °C 70 °C
Extended ambient conditions				
<ul style="list-style-type: none"> Relative to ambient temperature-atmospheric pressure-installation altitude Relative humidity - With condensation/maximum/ tested in accordance with IEC 60068-2-38 Resistance - to biologically active substances - to chemically active substances - to mechanically active substances 	<p>Tmin ... Tmax at 1080 hPa ... 795 hPa (-1000 m ... +2000 m) // Tmin ... (Tmax - 10K) at 795 hPa ... 658 hPa (+2000 m ... +3500 m) // Tmin ... (Tmax - 20K) at 658 hPa ... 540 hPa (+3500 m ... +5000 m)</p> <p>100 %; RH incl. condensation/frost (no commissioning under condensation conditions)</p> <p>Yes; Class 3B2 mold, fungus and dry rot spores (with the exception of fauna). The supplied connector covers must remain on the unused interfaces during operation!</p> <p>Yes; Class 3C4 (RH < 75%) incl. salt spray according to EN 60068-2-52 (degree of severity 3). The supplied connector covers must remain on the unused interfaces during operation!</p> <p>Yes; Class 3S4 incl. sand, dust. The supplied connector covers must remain on the unused interfaces during operation!</p>	<p>Tmin ... Tmax at 1080 hPa ... 795 hPa (-1000 m ... +2000 m) // Tmin ... (Tmax - 10K) at 795 hPa ... 658 hPa (+2000 m ... +3500 m) // Tmin ... (Tmax - 20K) at 658 hPa ... 540 hPa (+3500 m ... +5000 m)</p> <p>100 %; RH incl. condensation/frost (no commissioning under condensation conditions)</p> <p>Yes; Class 3B2 mold, fungus and dry rot spores (with the exception of fauna). The supplied connector covers must remain on the unused interfaces during operation!</p> <p>Yes; Class 3C4 (RH < 75%) incl. salt spray according to EN 60068-2-52 (degree of severity 3). The supplied connector covers must remain on the unused interfaces during operation!</p> <p>Yes; Class 3S4 incl. sand, dust. The supplied connector covers must remain on the unused interfaces during operation!</p>	<p>Tmin ... Tmax at 1080 hPa ... 795 hPa (-1000 m ... +2000 m) // Tmin ... (Tmax - 10K) at 795 hPa ... 658 hPa (+2000 m ... +3500 m) // Tmin ... (Tmax - 20K) at 658 hPa ... 540 hPa (+3500 m ... +5000 m)</p> <p>100 %; RH incl. condensation/frost (no commissioning under condensation conditions)</p> <p>Yes; Class 3B2 mold, fungus and dry rot spores (with the exception of fauna). The supplied connector covers must remain on the unused interfaces during operation!</p> <p>Yes; Class 3C4 (RH < 75%) incl. salt spray according to EN 60068-2-52 (degree of severity 3). The supplied connector covers must remain on the unused interfaces during operation!</p> <p>Yes; Class 3S4 incl. sand, dust. The supplied connector covers must remain on the unused interfaces during operation!</p>	<p>Tmin ... Tmax at 1080 hPa ... 795 hPa (-1000 m ... +2000 m) // Tmin ... (Tmax - 10K) at 795 hPa ... 658 hPa (+2000 m ... +3500 m) // Tmin ... (Tmax - 20K) at 658 hPa ... 540 hPa (+3500 m ... +5000 m)</p> <p>100 %; RH incl. condensation/frost (no commissioning under condensation conditions)</p> <p>Yes; Class 3B2 mold, fungus and dry rot spores (with the exception of fauna). The supplied connector covers must remain on the unused interfaces during operation!</p> <p>Yes; Class 3C4 (RH < 75%) incl. salt spray according to EN 60068-2-52 (degree of severity 3). The supplied connector covers must remain on the unused interfaces during operation!</p> <p>Yes; Class 3S4 incl. sand, dust. The supplied connector covers must remain on the unused interfaces during operation!</p>

SIMATIC ET 200 distributed I/O

ET 200SP

SIPLUS BaseUnits

Ordering data	Order No.	Order No.	
SIPLUS BaseUnits type A0 BU15-P16+A0+2D (Extended temperature range and medial exposure) BU type A0; BaseUnit (light) with 16 process terminals to the module; for starting a new load group (max. 10 A)	6AG1 193-6BP00-7DA0	SIPLUS BaseUnits type A1 (with temperature detection) BU15-P16+A0+2D/T (Extended temperature range and medial exposure) BU type A1; BaseUnit (light) with 16 process terminals to the module; for starting a new load group (max. 10 A)	6AG1 193-6BP00-7DA1
BU15-P16+A0+2B (Extended temperature range and medial exposure) BU type A0; BaseUnit (dark) with 16 process terminals to the module; for continuing the load group	6AG1 193-6BP00-7BA0	BU15-P16+A0+2B/T (Extended temperature range and medial exposure) BU type A1; BaseUnit (dark) with 16 process terminals to the module; for continuing the load group	6AG1 193-6BP00-7BA1
BU15-P16+A10+2D (Extended temperature range and medial exposure) BU type A0; BaseUnit (light) with 16 process terminals (1 ... 16) on the module and an additional 10 internally jumpered AUX terminals (1A to 10A); for starting a new load group (max. 10 A)	6AG1 193-6BP20-7DA0	BU15-P16+A0+12D/T (Extended temperature range and medial exposure) BU type A1; BaseUnit (light) with 16 process terminals (1 ... 16) on the module and an additional 2x5 internally jumpered AUX terminals (1 B to 5 B and 1 C to 5 C); for starting a new load group (max. 10 A)	6AG1 193-6BP40-7DA1
BU15-P16+A10+2B (Extended temperature range and medial exposure) BU type A0; BaseUnit (dark) with 16 process terminals (1 ... 16) on the module and an additional 10 internally jumpered AUX terminals (1A to 10A); for continuing the load group	6AG1 193-6BP20-7BA0	BU15-P16+A0+12B/T (Extended temperature range and medial exposure) BU type A1; BaseUnit (dark) with 16 process terminals (1 ... 16) on the module and an additional 2x5 internally jumpered AUX terminals (1 B to 5 B and 1 C to 5 C); for starting a new load group	6AG1 193-6BP40-7BA1
		Accessories	siehe SIMATIC ET 200SP BaseUnits, page 9/33

Overview



Bus adapter BA 2xRJ45



Bus adapter BA 2xFC

The interface modules of the SIMATIC ET 200SP have a universal PROFINET interface for bus adapters. With the appropriate bus adapter, the type of connection can be adapted to the requirements of the respective application:

- For standard applications with a moderate mechanical and EMC load, the BA 2xRJ45 bus adapter is used. It offers two sockets for standard RJ45 plugs.
- For machines and systems in which higher mechanical and/or EMC loads act on the devices, the BA 2xFC bus adapter is recommended. In this case, the bus cables are connected directly by means of FastConnect terminals – similar to the PROFIBUS connector, proven in millions of applications. The technology is extremely quick to assemble and achieves 5 times better vibration resistance and also 5 times greater resistance to electromagnetic interference, when compared to RJ45 plug-in connectors.

Another advantage of the bus adapters: In order to repair defective RJ45 jacks or for the later conversion to the rugged FastConnect technology, only the adapter needs to be replaced.

Ordering data

Order No.

Bus adapter BA 2xRJ45 6ES7 193-6AR00-0AA0

Bus adapter BA 2xFC 6ES7193-6AF00-0AA0

Reference identification label 6ES7 193-6LF30-0AW0

10 sheets of 16 labels

IE FC RJ45 plugs

RJ45 plug connector for Industrial Ethernet with a rugged metal enclosure and integrated insulation displacement contacts for connecting Industrial Ethernet FC installation cables

IE FC RJ45 Plug 180

180° cable outlet

1 unit

6GK1 901-1BB10-2AA0

10 units

6GK1 901-1BB10-2AB0

50 units

6GK1 901-1BB10-2AE0

SIMATIC ET 200 distributed I/O

ET 200SP

Accessories

Overview

Labeling strips

- Labeling strips for ET 200SP
- Can be used for the interface module, bus adapter, I/O module and BU cover

Reference identification labels



- For the labeling of ET 200SP components with a reference code (equipment identifier)
- Can be used for the interface module, I/O module, bus adapter and BU cover

BU cover

- Protective cover for empty slots of an ET 200SP
- For protecting the plug-in connectors of a BaseUnit without I/O module

Color-coding plates

- For module-specific identification of the potentials at the terminals of the BaseUnit
- For the prevention of wiring faults

Shield connection

- Simple, quick-mounting shield connection
- For space-saving and optimized connection of cable shields from EMC viewpoint

Ordering data

Order No.

Labeling strips 1 roll of 500 strips	6ES7 193-6LR10-0AA0
Reference identification label 10 sheets of 16 labels	6ES7 193-6LF30-0AW0
BU cover, 15 mm for covering empty slots (gaps); 5 units	6ES7 133-6CV15-1AM0
Color-coding plates	
• Color code CC01, module-specific, for 16 push-in terminals; 10 units	6ES7 193-6CP01-2MA0
• Color code CC02, module-specific, for 16 push-in terminals; 10 units	6ES7 193-6CP02-2MA0
• Color code CC03, module-specific, for 16 push-in terminals; 10 units	6ES7 193-6CP03-2MA0
• Color code CC04, module-specific, for 16 push-in terminals; 10 units	6ES7 193-6CP04-2MA0
• Color code CC71, for 10 AUX terminals, for BU type A0, with push-in terminals; 10 units	6ES7 193-6CP71-2AA0
Shield connection	6ES7 193-6SC00-1AM0
5 shield supports and 5 shield terminals	
• Color code CC72, for 10 AUX terminals, for BU type A0, with push-in terminals; 10 units	6ES7 193-6CP72-2AA0
• Color code CC73, for 10 AUX terminals, for BU type A0, with push-in terminals; 10 units	6ES7 193-6CP73-2AA0
• Color code CC74, for 2x5 additional terminals, for BU type A1, with push-in terminals; 10 units	6ES7 193-6CP74-2AA0

Overview

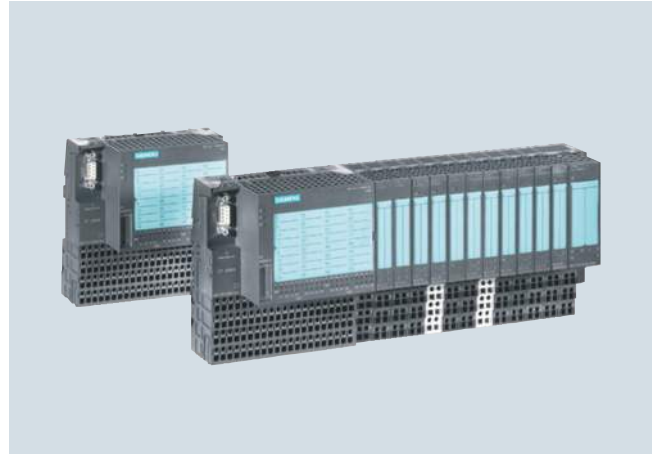
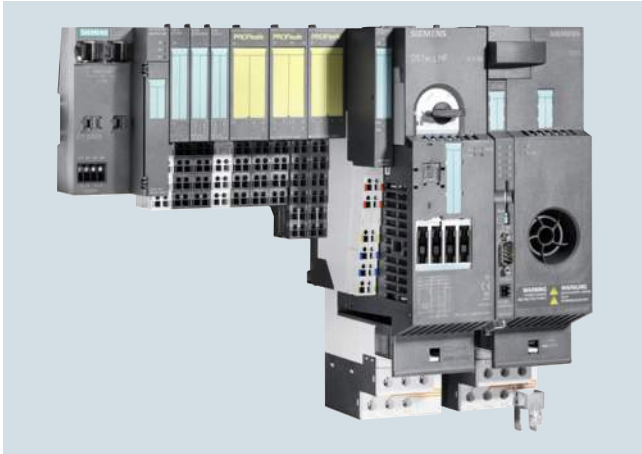

SIMATIC ET 200S

- Distributed I/O system to degree of protection IP20 with minimal wiring outlay, also for extremely time-critical tasks such as high-speed closed-loop controls
- Can be used with integrated S7-CPU as mini PLC:
 - also available as fail-safe PROFIsafe version
 - with optional lower-level PROFIBUS DP
- Bit-modular design for exact adaptation to the automation task in hand.
- Interface modules available with PROFIBUS DP or PROFINET interfaces
- Can be combined from digital and analog in/output modules, technology modules, motor starters and frequency converters for the control of drives up to 7.5 or 4 kW.
- Exchange of modules during operation (hot swapping), permanent wiring with multi-conductor connection
- Channel-specific diagnostics for high availability
- Can be supplied with integrated fiber optic interface if required
- Transmission rates up to 12 Mbit/s
- FastConnect using unstripped quick connection technology, screw or spring-loaded terminals
- Ex approval to Cat. 3 for Zone 2 acc. to ATEX100 a
- Slot reservation with spare modules
- Failsafe DI modules with safety-related signal processing according to PROFIsafe
- Option handling – for simplest management of machine options

SIMATIC ET 200S COMPACT

- Block I/O to degree of protection IP20 with 32 channels, comprising terminal block and electronic block
- Discretely modular expansion to maximum of 128 channels or 12 modules
- The complete ET 200S module spectrum can be used (with the exception of PROFIsafe modules)
- Separation of terminal connections and electronics with permanent wiring
- Screw-type and spring-loaded terminal connections
- Standard terminal block with 2-wire connection system; 3-wire and 4-wire systems available using additional terminals
- Mounting on standard rail
- Hot swapping of expansion modules
- Communication via PROFIBUS
- Up to 100 byte inputs and outputs (address space)

SIMATIC ET 200 distributed I/O

ET 200S

ET 200S

Technical specifications

General technical specifications

Degree of protection	IP20
Ambient temperature	0 ... 60 °C
Vibration resistance	2 g continuously, 5 g temporarily (motor starter max. 2 g)
Maximum configuration (none of the limits listed below must be exceeded)	
• Number of modules per IM 151, max.	IM 151-1 BASIC: Up to 12 modules IM 151-1 COMPACT: Up to 12 modules IM 151-1 STANDARD: Up to 63 modules IM 151-1 HIGH-FEATURE: Up to 63 modules IM 151-7 CPU: Up to 63 modules IM 151-3 PN: Up to 63 modules IM 151-1 BASIC: Up to 2 m IM 151-1 COMPACT: Up to 2 m IM 151-1 STANDARD: Up to 2 m IM 151-1 HIGH-FEATURE: Up to 2 m IM 151-7 CPU: Up to 1 m IM 151-3 PN: Up to 2 m
• Line width, max.	Depending on the number and type of connected modules IM 151-1 BASIC: Up to 88 byte for inputs and outputs IM 151-1 COMPACT: Up to 100 byte for inputs and outputs IM 151-1 STANDARD: Up to 244 byte for inputs and outputs IM 151-1 HIGH-FEATURE: Up to 244 byte for inputs and outputs IM 151-7 CPU: Not relevant IM 151-3 PN: 256 byte
• User data length	Depending on the number and type of connected modules IM 151-1 BASIC: 198 byte IM 151-1 COMPACT: 218 byte IM 151-1 STANDARD: Up to 244 byte IM 151-1 HIGH-FEATURE: Up to 244 byte IM 151-7 CPU: Not relevant IM 151-3 PN: Not relevant
• Parameter length	Depending on the number and type of connected modules IM 151-1 BASIC: 198 byte IM 151-1 COMPACT: 218 byte IM 151-1 STANDARD: Up to 244 byte IM 151-1 HIGH-FEATURE: Up to 244 byte IM 151-7 CPU: Not relevant IM 151-3 PN: Not relevant

General technical specifications

Requirements of the DP master system	
• PROFIBUS DP master	In accordance with EN 50170
• Parameter length	>32 byte, depending on the number and type of connected modules
• User data length	Depending on the number and type of connected modules
• Diagnostics length	17 ... 64 byte (adjustable)
Standards and approvals	
• PROFIBUS	EN 50170, Volume 2
• IEC 1131	IEC 1131, Part 2
• UL	acc. to UL508 standard, File No. E 116536/E 75310 (AC modules)
• C-Tick	AS/NZS 2064 (Class A)
• CSA	acc. to standard C22.2 No. 142, File No. LR 48323/LR 44226 (AC modules)
• cULus for hazardous locations	acc. to UL 508 standard, File No. E 116536 acc. to hazardous locations UL 1604, File no. E 222109 acc. to CSA C22.2 standard, No. 142
• FM	Standard Class No. 3611, Class I, Division 2, Group A, B, C, D, Class I, Zone 2, Group IIC (without motor starter and frequency converter)
• Shipbuilding	American Bureau of Shipping Bureau Veritas Det Norske Veritas Germanischer Lloyd Lloyds Register of Shipping Nippon Kaiji Kyokai (without motor starters and frequency converters)
• Ex approval Cat. 3 (for Zone 2 acc. to ATEX-100a)	EN 50021 (without frequency converters)

Within the context of converting SIMATIC from UL / CSA to cULus, the ET 200S modules will also be converted

Overview



- Interface module for SIMATIC ET 200S with integrated S7-CPU 314
- For high-performance control solutions in ET 200S
- Increases the availability of plants and machinery
- Programming via PROFIBUS DP
- Compact SIMATIC Micro Memory Card (MMC)
- Integrated 12 Mbit/s PROFIBUS DP slave/MPI interface in copper design
- Integrated CPU based on CPU S7-314
- IM 151-7 CPU FO available
- Fail-safe IM 151-7 F-CPU PROFIsafe available
- Also available as IM 151-8(F) PN/DP CPU with PROFINET interface

Note:

Micro Memory Card required for operation of CPU.

Technical specifications

	6ES7 151-7AB00-0AB0	6ES7 151-7AA21-0AB0
General information		
Engineering with		
• Programming package	STEP 7 V5.1 or higher	V5.5 + SP1 or higher or V5.2 + SP1 or higher + HSP 219
Supply voltage		
24 V DC	Yes	Yes
Power losses		
Power loss, typ.	3.3 W	4.2 W
Memory		
Work memory		
• integrated	48 kbyte; as of FW V1.13 48 KB; previously 24 KB	128 kbyte
• Size of retentive memory for retentive data blocks		64 kbyte
Load memory		
• pluggable (MMC), max.	2 Mbyte	8 Mbyte
CPU processing times		
for bit operations, typ.	0.3 μs	0.06 μs
for word operations, typ.	1 μs	0.12 μs
for fixed point arithmetic, typ.	2 μs	0.16 μs
for floating point arithmetic, typ.	50 μs	0.59 μs
Counters, timers and their retentivity		
S7 counter		
• Number	64	256
IEC counter		
• present	Yes	Yes
S7 times		
• Number	128	256
IEC timer		
• present	Yes	Yes
Data areas and their retentivity		
Flag		
• Number, max.	256 byte	256 byte
Address area		
I/O address area		
• Inputs	1 536 byte	2 048 byte
• Outputs	1 536 byte	2 048 byte
Process image		
• Inputs, adjustable		2 048 byte
• Outputs, adjustable		2 048 byte

SIMATIC ET 200 distributed I/O

ET 200S

Interface modules with CPU IM 151-7 CPU

Technical specifications (continued)

	6ES7 151-7AB00-0AB0	6ES7 151-7AA21-0AB0
Time of day		
Clock		
• Hardware clock (real-time clock)		Yes
Operating hours counter		
• Number	0; No	1
1st interface		
Type of interface	Fiber-optic interface and integrated RS 485 interface for programming	Integrated RS 485 interface
Physics	Fiber-optic cable or RS 485	RS 485
Functionality		
• MPI	No	Yes
• DP master		No
• DP slave	Yes	Yes; active / passive
• Point-to-point connection	No	No
2nd interface		
Type of interface		External interface via master module 6ES7138-4HA00-0AB0
Physics		RS 485
Functionality		
• MPI		No
• DP master		Yes
• DP slave		No
DP master		
• Number of DP slaves, max.		32; Per station
Isochronous mode		
Isochronous operation (application synchronized up to terminal)		No
Communication functions		
PG/OP communication	Yes	Yes
Data record routing		Yes; With DP master module
Global data communication		
• supported	No	Yes
S7 basic communication		
• supported	Yes; as server	Yes
S7 communication		
• supported	Yes	Yes
S5-compatible communication		
• supported	No	
Standard communication (FMS)		
• supported	No	
Number of connections		
• overall		12
Ambient conditions		
Operating temperature		
• Min.	0 °C	
• max.	60 °C	
Configuration		
Configuration software		
• STEP 7 Lite	Yes; V2.0 or higher	No
programming		
• Programming language		
- LAD	Yes	Yes
- FBD	Yes	Yes
- STL	Yes	Yes
- SCL	Yes	Yes; optional
- CFC		Yes; optional
- GRAPH		Yes; optional
- HiGraph®		Yes; optional
Know-how protection		
• User program protection/password protection	Yes	Yes
• Block encryption		Yes; With S7 block Privacy

Technical specifications (continued)

	6ES7 151-7AB00-0AB0	6ES7 151-7AA21-0AB0
Dimensions		
Width	60 mm	60 mm; DP master module: 35 mm
Height	119.5 mm	119.5 mm
Depth	75 mm	75 mm
Weight		
Weight, approx.	200 g	200 g; DP master module: Approx. 100 g

Ordering data	Order No.	Order No.
IM 151-7 CPU FO interface module (48 K) Including termination module	6ES7 151-7AB00-0AB0	ET 200S distributed I/O system manuals are available on the Internet as PDF files: www.siemens.com/simatic-docu
IM 151-7 CPU interface module (128 K) V3.3 Including termination module	6ES7 151-7AA21-0AB0	Termination module as spare part for ET 200S
Accessories		Power supply connector Spare part; for connecting the 24 V DC supply voltage • with push-in terminals
MMC 64 KB ¹⁾ for program backup	6ES7 953-8LF20-0AA0	SIMATIC S5, 35 mm DIN rail • Length: 483 mm for 19" cabinets • Length: 530 mm for 600 mm cabinets • Length: 830 mm for 900 mm cabinets • Length: 2 m
MMC 128 KB ¹⁾ for program backup	6ES7 953-8LG20-0AA0	PROFIBUS DP bus connector RS 485 with 90° cable outlet, max. transfer rate 12 Mbit/s • Without PG interface • with PG interface
MMC 512 KB ¹⁾ for program backup	6ES7 953-8LJ30-0AA0	with 90° cable outlet for FastConnect connection system, max. transfer rate 12 Mbit/s • without PG interface, 1 unit • without PG interface, 100 units • with PG interface, 1 unit • with PG interface, 100 units
MMC 2 MB ¹⁾ For program backup and/or firmware update	6ES7 953-8LL31-0AA0	PROFIBUS Fast Connect bus cable Standard type with special design for quick mounting, 2-core, shielded, sold by the meter, max. delivery unit 1000 m, minimum ordering quantity 20 m
MMC 4 MB ¹⁾ for program backup	6ES7 953-8LM20-0AA0	PROFIBUS bus components For establishing MPI/PROFIBUS communication
MMC 8 MB ¹⁾ for program backup	6ES7 953-8LP20-0AA0	
External prommer e.g. for MMC with USB interface	6ES7 792-0AA00-0XA0	
PG With integrated MMC interface	on request	
Label sheets DIN A4 (10 pieces) Each sheet contains 60 labeling strips for peripheral modules and 20 labeling strips for interface modules • petrol • red • yellow • light beige	6ES7 193-4BH00-0AA0 6ES7 193-4BD00-0AA0 6ES7 193-4BB00-0AA0 6ES7 193-4BA00-0AA0	

1) An MMC is essential for operating the CPU

SIMATIC ET 200 distributed I/O

ET 200S

Interface modules with CPU IM 151-8 PN/DP CPU

Overview



- Interface module for SIMATIC ET 200S with integrated CPU S7-314
- For high-performance control solutions in ET 200S
- Increase of the availability of systems and machines
- PROFINET IO Controller for up to 128 IO Devices
- PROFINET I-Device for connecting the CPU as an intelligent PROFINET device under a SIMATIC or non-Siemens PROFINET IO controller
- PROFINET interface with integrated 3-port switch
- Isochronous mode on PROFINET
- With many communication options: PG/OP communication, PROFINET IO, PROFINET CBA, open IE communication (TCP, ISO-on-TCP and UDP), web server and S7-communication (with loadable FBs)
- Fast, simple and end-to-end programming of a system with modular programs via STEP 7
- Compact SIMATIC Micro Memory Card (MMC)
- Optional PROFIBUS master for 32 PROFIBUS DP slaves (with master interface 6ES7138-4HA00-0AB0)
- Fail-safe IM 151-8F PN/DP CPU PROFIsafe available

Note:

SIMATIC Micro Memory Card required for operation of CPU.

Technical specifications

	6ES7 151-8AB01-0AB0
General information	
Engineering with	
• Programming package	STEP7 V 5.5 or higher
Supply voltage	
24 V DC	Yes
Power losses	
Power loss, typ.	5.5 W
Memory	
Work memory	
• integrated	192 kbyte
• Size of retentive memory for retentive data blocks	64 kbyte
Load memory	
• pluggable (MMC), max.	8 Mbyte
CPU processing times	
for bit operations, typ.	0.06 µs
for word operations, typ.	0.12 µs
for fixed point arithmetic, typ.	0.16 µs
for floating point arithmetic, typ.	0.59 µs
Counters, timers and their retentivity	
S7 counter	
• Number	256
IEC counter	
• present	Yes
S7 times	
• Number	256
IEC timer	
• present	Yes
Data areas and their retentivity	
Flag	
• Number, max.	256 byte

	6ES7 151-8AB01-0AB0
Address area	
I/O address area	
• Inputs	2 048 byte
• Outputs	2 048 byte
Process image	
• Inputs, adjustable	2 048 byte
• Outputs, adjustable	2 048 byte
Time of day	
Clock	
• Hardware clock (real-time clock)	Yes
Operating hours counter	
• Number	1
1st interface	
Type of interface	PROFINET
Physics	
Number of ports	3; RJ45
Functionality	
• MPI	No
• DP master	No
• DP slave	No
• PROFINET IO Device	Yes; Also simultaneously with IO Controller functionality
• PROFINET IO Controller	Yes; Also simultaneously with IO-Device functionality
• PROFINET CBA	Yes
• Point-to-point connection	No
PROFINET IO Controller	
• Max. number of connectable IO devices for RT	128
• Number of IO devices with IRT and the option "high flexibility"	128
• Number of IO Devices with IRT and the option "high performance", max.	64

Technical specifications (continued)

6ES7 151-8AB01-0AB0	
2nd interface	
Type of interface	External interface via master module 6ES7 138-4HA00-0AB0
Physics	RS 485
Functionality	
• MPI	No
• DP master	Yes
• DP slave	No
• PROFINET IO Controller	No
• PROFINET IO Device	No
• PROFINET CBA	No
DP master	
• Number of DP slaves, max.	32; Per station
Isochronous mode	
Isochronous operation (application synchronized up to terminal)	No
Communication functions	
PG/OP communication	Yes
Data record routing	Yes; With DP master module
Global data communication	
• supported	No
S7 basic communication	
• supported	Yes; I blocks
S7 communication	
• supported	Yes
Open IE communication	
• TCP/IP	Yes; via integrated PROFINET interface and loadable FBs 8
- Number of connections, max.	8
• ISO-on-TCP (RFC1006)	Yes; via integrated PROFINET interface and loadable FBs 8
- Number of connections, max.	8
• UDP	Yes; via integrated PROFINET interface and loadable FBs 8
- Number of connections, max.	8
Web server	
• supported	Yes
Number of connections	
• overall	12

6ES7 151-8AB01-0AB0	
Configuration	
programming	
• Programming language	Yes
- LAD	Yes
- FBD	Yes
- STL	Yes; optional
- SCL	Yes; optional
- CFC	Yes; optional
- GRAPH	Yes; optional
- HiGraph®	Yes; optional
Know-how protection	
• User program protection/password protection	Yes
• Block encryption	Yes; With S7 block Privacy
Dimensions	
Width	120 mm; DP master module: 35 mm
Height	119.5 mm
Depth	75 mm
Weight	
Weight, approx.	320 g; DP master module: Approx. 100 g

SIMATIC ET 200 distributed I/O

ET 200S

Interface modules with CPU IM 151-8 PN/DP CPU

Ordering data	Order No.	Order No.
IM 151-8 PN/DP CPU interface module (192 K) Including termination module Accessories MMC 64 KB ¹⁾ for program backup MMC 128 KB ¹⁾ for program backup MMC 512 KB ¹⁾ for program backup MMC 2 MB ¹⁾ for program backup and/or firmware update MMC 4 MB ¹⁾ for program backup MMC 8 MB ¹⁾ for program backup External prommer for MMC, among others, with USB interface PG with integrated MMC interface Label sheets DIN A4 (10 units) Each sheet contains 60 label strips for peripheral modules and 20 label strips for interface modules <ul style="list-style-type: none"> • petrol • red • yellow • light beige 	6ES7 151-8AB01-0AB0 6ES7 953-8LF20-0AA0 6ES7 953-8LG20-0AA0 6ES7 953-8LJ30-0AA0 6ES7 953-8LL31-0AA0 6ES7 953-8LM20-0AA0 6ES7 953-8LP20-0AA0 6ES7 792-0AA00-0XA0 On request 6ES7 193-4BH00-0AA0 6ES7 193-4BD00-0AA0 6ES7 193-4BB00-0AA0 6ES7 193-4BA00-0AA0	ET 200S distributed I/O system manuals are available on the Internet as PDF files: www.siemens.com/simatic-docu Terminating module as spare part for ET 200S Power supply connector Spare part; for connecting the 24 V DC supply voltage <ul style="list-style-type: none"> • with push-in terminals SIMATIC S5, 35 mm DIN rail <ul style="list-style-type: none"> • Length: 483 mm for 19" cabinets • Length: 530 mm for 600 mm cabinets • Length: 830 mm for 900 mm cabinets • 2 m long Industrial Ethernet FC RJ45 Plug 90 RJ45 plug connector for Industrial Ethernet with a rugged metal enclosure and integrated insulation displacement contacts for connecting Industrial Ethernet FC installation cables; with 90° cable outlet <ul style="list-style-type: none"> • 1 unit • 10 units • 50 units Industrial Ethernet FastConnect installation cables <ul style="list-style-type: none"> • Fast Connect standard cable • Fast Connect trailing cable • Fast Connect marine cable Industrial Ethernet FastConnect Stripping Tool
		6ES7 193-4JA00-0AA0 6ES7 193-4JB00-0AA0 6ES5 710-8MA11 6ES5 710-8MA21 6ES5 710-8MA31 6ES5 710-8MA41 6GK1 901-1BB20-2AA0 6GK1 901-1BB20-2AB0 6GK1 901-1BB20-2AE0 6XV1 840-2AH10 6XV1 840-3AH10 6XV1 840-4AH10 6GK1 901-1GA00

¹⁾ An MMC is essential to operate the CPU

Overview



PROFIBUS DP master interface module for IM 151-7(F) CPU (not IM 151-7 CPU FO) and IM 151-8(F) PN/DP CPU interface modules

- Integrated 12 Mbit/s PROFIBUS DP master interface in copper design
- Facilitates parallel operation of two PROFIBUS DP interfaces on one IM 151-7 (F-)CPU
- Enables operation of a PROFIBUS DP interface on an IM 151-8(F) PN/DP CPU
- Increases the availability of plants and machinery
- Functionality corresponds to the interface of an S7-300 CPU 314-2 DP configured as DP master

Programming is with STEP7 from Version V5.2 with Service Pack 1.

Technical specifications

6ES7 138-4HA00-0AB0	
Hardware configuration	
Number of modules per CPU	1
Dimensions	
Width	35 mm
Height	119.5 mm
Depth	75 mm
Weight	
Weight, approx.	100 g

Ordering data

Ordering data	Order No.
Master interface module for IM 151-7 CPU / IM 151-7 F-CPU / IM 151-8 PN/DP CPU / IM 151-8F PN/DP CPU interface modules Note: Not for IM 151-7 CPU FO	6ES7 138-4HA00-0AB0
Accessories PROFIBUS DP bus connector RS 485 with 90° cable outlet, max. transfer rate 12 Mbit/s • Without PG interface • with PG interface with 90° cable outlet for FastConnect connection system, max. transfer rate 12 Mbit/s • without PG interface, 1 unit • without PG interface, 100 units • with PG interface, 1 unit • with PG interface, 100 units	6ES7 972-0BA12-0XA0 6ES7 972-0BB12-0XA0 6ES7 972-0BA52-0XA0 6ES7 972-0BA52-0XB0 6ES7 972-0BB52-0XA0 6ES7 972-0BB52-0XB0
PROFIBUS FastConnect bus cable Standard type with special design for quick mounting, 2-core, shielded, sold by the meter, max. delivery unit 1000 m, minimum ordering quantity 20 m	6XV1 830-0EH10
PROFIBUS bus components For establishing MPI/PROFIBUS communication	See IK PI, CA 01 catalogs
Label sheets DIN A4 (10 pieces) Each sheet contains 60 labeling strips for peripheral modules and 20 labeling strips for interface modules • petrol • red • yellow • light beige	6ES7 193-4BH00-0AA0 6ES7 193-4BD00-0AA0 6ES7 193-4BB00-0AA0 6ES7 193-4BA00-0AA0
ET 200S distributed I/O system manuals are available on the Internet as PDF files: www.siemens.com/simatic-docu	

SIMATIC ET 200 distributed I/O

ET 200S

SIPLUS interface modules with CPU
SIPLUS IM151-7 CPU

Overview



- Interface module for SIMATIC ET 200S with integrated S7-CPU 314
- For high-performance control solutions in ET 200S
- Increase of the availability of systems and machines
- Programming via PROFIBUS DP
- Compact SIMATIC micro memory card (MMC)
- Integrated 12 Mbit/s PROFIBUS DP slave/MPI interface in Cu version
- Integrated CPU based on the CPU S7-314
- IM 151-7 CPU FO available
- Failsafe IM 151-7 F-CPU PROFIsafe available
- Alternatively, as IM 151-8 (F) PN/DP CPU with PROFINET interface

Micro Memory Card required for operation of CPU.

Note:

SIPLUS extreme products are based on Siemens Industry standard products. The contents listed here were taken from the respective standard products. SIPLUS extreme specific information was added.

SIPLUS IM151-7 CPU	
Order No.	6AG1151-7AA21-2AB0
Order No. based on	6ES7151-7AA21-0AB0
Ambient temperature range	-25 °C ... +60 °C
Conformal coating	Coating of the printed circuit boards and the electronic components
Technical data	The technical data of the standard product applies for the ambient conditions.
Ambient conditions	
Relative humidity	100%, condensation/frost permissible. No commissioning if condensation present.
Biologically active substances, compliance with EN 60721-3-3	Class 3B2 mold and fungal spores (excluding fauna). The supplied plug covers must remain in place over the unused interfaces during operation!
Chemically active substances, compliance with EN 60721-3-3	Class 3C4 incl. salt spray in accordance with EN60068-2-52 (degree of severity 3). The supplied plug covers must remain in place over the unused interfaces during operation!
Mechanically active substances, compliance with EN 60721-3-3	Class 3S4 incl. sand, dust. The supplied plug covers must remain in place over the unused interfaces during operation!
Air pressure (depending on the highest positive temperature range specified)	1,080...795 hPa (-1,000 ... +2,000 m) See ambient temperature range 795...658 hPa (+2 000 ... +3 500m) Derating 10 K 658 ... 540 hPa (+3 500 ... +5 000 m) derating 20 K

For technical documentation on SIPLUS, see:

<http://www.siemens.com/siplus-extreme>

Ordering data	Order No.
SIPLUS IM 151-7 CPU interface module (96 K) (extended temperature range and medial exposure)	6AG1 151-7AA21-2AB0
SIPLUS ET 200S terminating module	6AG1 193-4JA00-2AA0
Accessories	See SIMATIC IM 151-7 CPU interface module, page 9/43

SIMATIC ET 200 distributed I/O

ET 200S

SIPLUS interface modules with CPU SIPLUS IM151-8 PN/DP CPU

Overview



- Interface module for SIMATIC ET 200S with integrated CPU S7-314
- For high-performance control solutions in ET 200S
- Increases the availability of plants and machinery
- PROFINET IO Controller for up to 128 IO devices
- PROFINET I-Device for connecting the CPU as an intelligent PROFINET device with a SIMATIC or third-party PROFINET I/O Controller
- PROFINET interface with integrated 3-port switch
- Isochronous mode on PROFINET
- With multiple communication options: PG/OP communication, PROFINET IO, PROFINET CBA, open IE communication (TCP, ISO-on-TCP and UDP), Web server and S7 communication (with loadable FBs)
- Fast, simple and uniform programming of a system with modular programs via STEP 7
- Compact SIMATIC Micro Memory Card (MMC)
- Optional PROFIBUS master for 32 PROFIBUS DP slaves (with master interface 6ES7 138-4HA00-0AB0)
- Fail-safe IM 151-8F PN/DP CPU PROFIsafe available

Micro Memory Card required for operation of CPU.

Note:

SIPLUS extreme products are based on Siemens Industry standard products. The contents listed here were taken from the respective standard products. SIPLUS extreme specific information was added.

SIPLUS IM 151-8 PN/DP CPU

Order No.	6AG1 151-8AB01-7AB0
Order number based on	6ES7 151-8AB01-0AB0
Ambient temperature range	-40 ... +70 °C
Conformal coating	Coating of the printed circuit boards and the electronic components
Technical data	The technical data of the standard product applies except for the ambient conditions.
Ambient conditions:	
Relative humidity	100%, condensation/frost permissible. No commissioning if condensation present.
Biologically active substances, compliance with EN 60721-3-3	Class 3B2 mold and fungal spores (excluding fauna). The supplied plug covers must remain in place over the unused interfaces during operation!
Chemically active substances, compliance with EN 60721-3-3	Class 3C4 incl. salt spray in accordance with EN60068-2-52 (degree of severity 3). The supplied plug covers must remain in place over the unused interfaces during operation!
Mechanically active substances, compliance with EN 60721-3-3	Class 3S4 incl. sand, dust. The supplied plug covers must remain in place over the unused interfaces during operation!
Air pressure (depending on the highest positive temperature range specified)	1 080...795 hPa (-1 000 ... +2 000 m) See ambient temperature range 795...658 hPa (+2 000 ... +3 500 m) Derating 10 K 658...540 hPa (+3 500 ... +5 000m) Derating 20K

For technical documentation on SIPLUS, see:

<http://www.siemens.com/siplus-extreme>

Ordering data

Order No.

SIPLUS interface module IM 151-8 PN/DP CPU

(extended temperature range and medial exposure)

Including termination module

- For areas with extreme medial exposure (conformal coating); ambient temperature -40 ... +70 °C

6AG1 151-8AB01-7AB0

Accessories

See SIMATIC IM 151-8 PN/DP CPU interface module, page 9/46

SIMATIC ET 200 distributed I/O

ET 200S

SIPLUS interface modules with CPU
SIPLUS master interface modules for IM 151 CPU

Overview



PROFIBUS DP master interface module for interface module IM 151-7 (R) CPU / IM 151-8 (F) PN/DP CPU

- Integrated 12 Mbit/s PROFIBUS DP master interface in Cu version
- Allows parallel operation of two PROFIBUS DP interfaces on one IM 151-7 CPU
- Allows operation of one PROFIBUS DP interface with an IM 151-8 (F) PN/DP CPU
- Increase in availability of systems and machines
- Functionality in accordance with a DP master configured interface of an S7-314 CPU

Programming is performed with STEP 7 from version V5.2 with Service Pack 1.

Note:

SIPLUS extreme products are based on Siemens Industry standard products. The contents listed here were taken from the respective standard products. SIPLUS extreme specific information was added.

SIPLUS master interface module for IM 151 CPU

Order number	6AG1 138-4HA00-7AB0
Order No. based on	6ES7 138-4HA00-0AB0
Ambient temperature range	-25 °C ... +70 °C
Conformal coating	Coating of the printed circuit boards and the electronic components
Technical data	The technical data of the standard product applies except for the ambient conditions.
Ambient conditions	
Relative humidity	100%, condensation/frost permissible. No commissioning if condensation present.
Biologically active substances, compliance with EN 60721-3-3	Class 3B2 mold and fungal spores (excluding fauna). The supplied plug covers must remain in place over the unused interfaces during operation!
Chemically active substances, compliance with EN 60721-3-3	Class 3C4 incl. salt spray in accordance with EN60068-2-52 (degree of severity 3). The supplied plug covers must remain in place over the unused interfaces during operation!
Mechanically active substances, compliance with EN 60721-3-3	Class 3S4 incl. sand, dust. The supplied plug covers must remain in place over the unused interfaces during operation!
Air pressure (depending on the highest positive temperature range specified)	1080 ... 795 hPa (-1000 ... +2000 m) See ambient temperature range 795 ... 658 hPa (+2000 ... +3500 m) derating 10 K 658 ... 540 hPa (+3500 ... +5000 m) derating 20 K

For technical documentation on SIPLUS, see:
<http://www.siemens.com/siplus-extreme>

Ordering data

Master interface module for SIPLUS M 151-7 CPU / IM 151-7 F-CPU / IM 151-8 PN/DP CPU / IM 151-8 F PN/DP CPU interface modules (extended temperature range and medial exposure)	6AG1 138-4HA00-7AB0
Accessories	See SIMATIC master interface module for IM 151 CPU, page 9/47

SIMATIC ET 200 distributed I/O

ET 200S

Interface module with fail-safe CPU
IM 151-7 F-CPU

Overview



- Interface module with integrated fail-safe CPU for SIMATIC ET 200S
- With DP/MPI interface
- For design of a fail-safe automation system for plants with increased safety requirements
- Complies with safety requirements up to SIL 3 according to IEC 61508, IEC 62061 and Cat. 4 according to EN 954-1
- Fail-safe I/O modules can be connected in a distributed configuration through DP master modules (PROFIsafe)
- The fail-safe I/O modules of ET200S PROFIsafe can be connected in a centralized configuration
- Standard modules can be used for non-safety-relevant applications

Note:

Micro Memory Card required for operation of CPU.

Technical specifications

6ES7 151-7FA21-0AB0	
General information	
Engineering with	
• Programming package	V5.5 + SP1 or higher or V5.2 + SP1 or higher + HSP 219 + Distributed Safety
Supply voltage	
24 V DC	Yes
Power losses	
Power loss, typ.	4.2 W
Memory	
Work memory	
• integrated	192 kbyte
• Size of retentive memory for retentive data blocks	64 kbyte
Load memory	
• pluggable (MMC), max.	8 Mbyte
CPU processing times	
for bit operations, typ.	0.06 µs
for word operations, typ.	0.12 µs
for fixed point arithmetic, typ.	0.16 µs
for floating point arithmetic, typ.	0.59 µs
Counters, timers and their retentivity	
S7 counter	
• Number	256
IEC counter	
• present	Yes
S7 times	
• Number	256
IEC timer	
• present	Yes
Data areas and their retentivity	
Flag	
• Number, max.	256 byte
Address area	
I/O address area	
• Inputs	2 048 byte
• Outputs	2 048 byte
Process image	
• Inputs, adjustable	2 048 byte
• Outputs, adjustable	2 048 byte

6ES7 151-7FA21-0AB0	
Time of day	
Clock	
• Hardware clock (real-time clock)	Yes
Operating hours counter	
• Number	1
1st interface	
Type of interface	Integrated RS 485 interface
Physics	RS 485
Functionality	
• MPI	Yes
• DP master	No
• DP slave	Yes; active / passive
• Point-to-point connection	No
2nd interface	
Type of interface	External interface via master module 6ES7138-4HA00-0AB0
Physics	RS 485
Functionality	
• MPI	No
• DP master	Yes
• DP slave	No
DP master	
• Number of DP slaves, max.	32; Per station
Isochronous mode	
Isochronous operation (application synchronized up to terminal)	No
Communication functions	
PG/OP communication	Yes
Data record routing	Yes; With DP master module
Global data communication	
• supported	Yes
S7 basic communication	
• supported	Yes
S7 communication	
• supported	Yes
Number of connections	
• overall	12

SIMATIC ET 200 distributed I/O

ET 200S

Interface module with fail-safe CPU IM 151-7 F-CPU

Technical specifications (continued)

6ES7 151-7FA21-0AB0	
Configuration	
Configuration software	
• STEP 7 Lite programming	No
programming	
• Programming language	
- LAD	Yes
- FBD	Yes
- STL	Yes
- SCL	Yes; optional
- CFC	Yes; optional
- GRAPH	Yes; optional
- HiGraph®	Yes; optional
Know-how protection	
• User program protection/ password protection	Yes
• Block encryption	Yes; With S7 block Privacy

6ES7 151-7FA21-0AB0	
Dimensions	
Width	60 mm; DP master module: 35 mm
Height	119.5 mm
Depth	75 mm
Weight	
Weight, approx.	200 g; DP master module: Approx. 100 g

Ordering data

IM151-7 F-CPU interface module

for configuring a fail-safe automation system

192 KB

Order No.

6ES7 151-7FA21-0AB0

Accessories

Distributed Safety V5.4 programming tool

Task:

Engineering tool for configuring fail-safe user programs for SIMATIC S7-300F, S7-400F, WinAC RTX F, ET 200S, ET 200M, ET 200iSP, ET 200pro, ET 200eco

Requirement:

STEP 7 V5.3 SP3 and higher

Floating license

6ES7 833-1FC02-0YA5

Floating license for 1 user, license key download without software and documentation¹⁾;

6ES7 833-1FC02-0YH5

email address required for delivery

Distributed Safety Upgrade

from V5.x to V5.4;

Floating license for 1 user

6ES7 833-1FC02-0YE5

STEP 7 Safety Advanced V11

Task:

Engineering tool for configuring fail-safe user programs for SIMATIC S7-300F, S7-400F, WinAC RTX F, ET 200S, ET 200M, ET 200iSP, ET 200pro, ET 200eco

Requirement:

STEP 7 Professional V11 SP1

Floating license for 1 user

6ES7 833-1FA11-0YA5

Floating license for 1 user, license key download without software and documentation¹⁾;

6ES7 833-1FA11-0YH5

email address required for delivery

Order No.

STEP 7 Safety Advanced Upgrade

Distributed Safety V5.4 SP5 and STEP 7 Safety Advanced V11 for parallel use; incl. software on CD; Combo License for 1 user

6ES7 833-1FA11-0YE5

Distributed Safety V5.4 SP5 and STEP 7 Safety Advanced V11 for parallel use; incl. software on CD; Combo License for 1 user, license key download without software and documentation¹⁾;

email address required for delivery

6ES7 833-1FA11-0YK5

MMC 64 kByte

for program backup

6ES7 953-8LF20-0AA0

MMC 128 kByte

for program backup

6ES7 953-8LG20-0AA0

MMC 512 kByte

for program backup

6ES7 953-8LJ30-0AA0

MMC 2 MByte

for program backup and/or firmware update

6ES7 953-8LL31-0AA0

MMC 4 MByte

for program backup

6ES7 953-8LM20-0AA0

External prommer

for MMC with USB interface

6ES7 792-0AA00-0XA0

Termination module

as spare part for ET 200S

6ES7 193-4JA00-0AA0

SIMATIC S5, 35 mm DIN rail

• Length: 483 mm for 19" cabinets

6ES5 710-8MA11

• Length: 530 mm for 600 mm cabinets

6ES5 710-8MA21

• Length: 830 mm for 900 mm cabinets

6ES5 710-8MA31

• Length: 2 m

6ES5 710-8MA41

¹⁾ For up-to-date information and download availability, see: <http://www.siemens.com/tia-online-software-delivery>

SIMATIC ET 200 distributed I/O

ET 200S

Interface module with fail-safe CPU
IM 151-8 F PN/DP CPU

Overview



- Interface module for SIMATIC ET 200S with integrated fail-safe CPU
- For constructing a fail-safe automation system for plants with increased safety requirements
- Complies with safety requirements up to SIL 3 according to IEC 61508, IEC 62061, up to PL_e according to ISO 13849-1:2006 and Cat. 4 according to EN 954-1
- For high-performance control solutions in ET 200S
- Increase of the availability of systems and machines
- PROFINET IO-Controller for up to 128 IO-Devices
- PROFINET interface with integrated 3-port switch
- With many communication options:
PG/OP communication, PROFINET IO, PROFINET CBA, open IE communication (TCP, ISO-on-TCP and UDP), web server and S7-communication (with loadable FBs)
- Fast, simple and end-to-end programming of a system with modular programs via STEP 7
- Compact SIMATIC Micro Memory Card (MMC)
- Optional PROFIBUS master for 32 PROFIBUS DP slaves (with master interface 6ES7138-4HA00-0AB0)

Note:

SIMATIC Micro Memory Card required for operation of CPU.

Technical specifications

6ES7 151-8FB01-0AB0	
General information	
Engineering with	
• Programming package	STEP 7 V 5.5 or higher, Distributed Safety V 5.4 SP4
Supply voltage	
24 V DC	Yes
Power losses	
Power loss, typ.	5.5 W
Memory	
Work memory	
• integrated	256 kbyte; For program and data
• Size of retentive memory for retentive data blocks	64 kbyte
Load memory	
• pluggable (MMC), max.	8 Mbyte
CPU processing times	
for bit operations, typ.	0.06 µs
for word operations, typ.	0.12 µs
for fixed point arithmetic, typ.	0.16 µs
for floating point arithmetic, typ.	0.59 µs
Counters, timers and their retentivity	
S7 counter	
• Number	256
IEC counter	
• present	Yes
S7 times	
• Number	256
IEC timer	
• present	Yes
Data areas and their retentivity	
Flag	
• Number, max.	256 byte

6ES7 151-8FB01-0AB0	
Address area	
I/O address area	
• Inputs	2 048 byte
• Outputs	2 048 byte
Process image	
• Inputs, adjustable	2 048 byte
• Outputs, adjustable	2 048 byte
Time of day	
Clock	
• Hardware clock (real-time clock)	Yes
Operating hours counter	
• Number	1
1st interface	
Type of interface	PROFINET
Physics	Ethernet
Number of ports	3; RJ45
Functionality	
• MPI	No
• DP master	No
• DP slave	No
• PROFINET IO Device	Yes; Also simultaneously with IO Controller functionality
• PROFINET IO Controller	Yes; Also simultaneously with IO-Device functionality
• PROFINET CBA	Yes
• Point-to-point connection	No
PROFINET IO Controller	
• Max. number of connectable IO devices for RT	128
• Number of IO devices with IRT and the option "high flexibility"	128
• Number of IO Devices with IRT and the option "high performance", max.	64

SIMATIC ET 200 distributed I/O

ET 200S

Interface module with fail-safe CPU
IM 151-8 F PN/DP CPU

Technical specifications (continued)

6ES7 151-8FB01-0AB0	
2nd interface	
Type of interface	External interface via master module 6ES7 138-4HA00-0AB0
Physics	RS 485
Functionality	
• MPI	No
• DP master	Yes
• DP slave	No
• PROFINET IO Controller	No
• PROFINET IO Device	No
• PROFINET CBA	No
DP master	
• Number of DP slaves, max.	32; Per station
Isochronous mode	
Isochronous operation (application synchronized up to terminal)	No
Communication functions	
PG/OP communication	Yes
Data record routing	Yes; With DP master module
Global data communication	
• supported	No
S7 basic communication	
• supported	Yes; I blocks
S7 communication	
• supported	Yes
Open IE communication	
• TCP/IP	Yes; via integrated PROFINET interface and loadable FBs
- Number of connections, max.	8
• ISO-on-TCP (RFC1006)	Yes; via integrated PROFINET interface and loadable FBs
- Number of connections, max.	8
• UDP	Yes; via integrated PROFINET interface and loadable FBs
- Number of connections, max.	8
Web server	
• supported	Yes
Number of connections	
• overall	12

6ES7 151-8FB01-0AB0	
Configuration	
programming	
• Programming language	
- LAD	Yes
- FBD	Yes
- STL	Yes
- SCL	Yes; optional
- CFC	Yes; optional
- GRAPH	Yes; optional
- HiGraph®	Yes; optional
Know-how protection	
• User program protection/password protection	Yes
• Block encryption	Yes; With S7 block Privacy
Dimensions	
Width	120 mm; DP master module: 35 mm
Height	119.5 mm
Depth	75 mm
Weight	
Weight, approx.	320 g; DP master module: Approx. 100 g

Ordering data	Order No.	Order No.
IM 151-8F PN/DP CPU interface module (256 K) Including termination module	6ES7 151-8FB01-0AB0	External prommer e.g. for MMC with USB interface
Distributed Safety V5.4 programming tool Task: Engineering tool for configuring fail-safe user programs for SIMATIC S7-300F, S7-400F, WinAC RTX F, ET 200S, ET 200M, ET 200iSP, ET 200pro, ET 200eco Requirement: STEP 7 V5.3 SP3 and higher Floating license	6ES7 833-1FC02-0YA5	6ES7 792-0AA00-0XA0 on request
Distributed Safety Upgrade from V5.x to V5.4; Floating license for 1 user	6ES7 833-1FC02-0YE5	PG with integrated MMC interface
STEP 7 Safety Advanced V11 Task: Engineering tool for configuring fail-safe user programs for SIMATIC S7-300F, S7-400F, WinAC RTX F, ET 200S, ET 200M, ET 200iSP, ET 200pro, ET 200eco Requirement: STEP 7 Professional V11 SP1 Floating license for 1 user	6ES7 833-1FA11-0YA5	Label sheets DIN A4 (10 pieces) Each sheet contains 60 labeling strips for peripheral modules and 20 labeling strips for interface modules • petrol • red • yellow • light beige
STEP 7 Safety Advanced Upgrade Distributed Safety V5.4 SP5 and STEP 7 Safety Advanced V11 for parallel use; incl. software on CD; Combo License for 1 user	6ES7 833-1FA11-0YE5	ET 200S distributed I/O system manuals are available on the Internet as PDF files: www.siemens.com/simatic-docu
Accessories		Termination module as spare part for ET 200S
MMC 64 KB ¹⁾ for program backup	6ES7 953-8LF20-0AA0	Power supply connector Spare part; for connecting the 24 V DC supply voltage • with push-in terminals
MMC 128 KB ¹⁾ for program backup	6ES7 953-8LG20-0AA0	6ES7 193-4JA00-0AA0
MMC 512 KB ¹⁾ for program backup	6ES7 953-8LJ30-0AA0	SIMATIC S5, 35 mm DIN rail • Length: 483 mm for 19" cabinets • Length: 530 mm for 600 mm cabinets • Length: 830 mm for 900 mm cabinets • Length: 2 m
MMC 2 MB ¹⁾ for program backup and/or firmware update	6ES7 953-8LL31-0AA0	6ES5 710-8MA11 6ES5 710-8MA21 6ES5 710-8MA31 6ES5 710-8MA41
MMC 4 MB ¹⁾ for program backup	6ES7 953-8LM20-0AA0	Industrial Ethernet FC RJ45 Plug 90 RJ45 plug connector for Industrial Ethernet with a rugged metal enclosure and integrated insulation displacement contacts for connecting Industrial Ethernet FC installation cables; with 90° cable outlet • 1 unit • 10 units • 50 units
MMC 8 MB ¹⁾ for program backup	6ES7 953-8LP20-0AA0	6GK1 901-1BB20-2AA0 6GK1 901-1BB20-2AB0 6GK1 901-1BB20-2AE0
		Industrial Ethernet FastConnect installation cables • Fast Connect standard cable • Fast Connect trailing cable • Fast Connect marine cable
		6XV1 840-2AH10 6XV1 840-3AH10 6XV1 840-4AH10
		Industrial Ethernet FastConnect stripping tool 6GK1 901-1GA00

¹⁾ An MMC is essential for operating the CPU

SIMATIC ET 200 distributed I/O

ET 200S

SIPLUS interface modules with fail-safe CPU
SIPLUS IM 151-7 F-CPU

Overview



- Interface module with integrated fail-safe CPU for SIMATIC ET 200S
- With DP/MPI interface
- For configuring a fail-safe automation system for plants with increased safety requirements
- Complies with safety requirements up to SIL 3 according to IEC 61508, IEC 62061 and Cat. 4 according to EN 954-1
- Fail-safe I/O modules can be connected in a distributed configuration using DP master modules (PROFIsafe)
- The ET 200S PROFIsafe fail-safe I/O modules can be connected in a centralized configuration
- Standard modules for non-safety-relevant applications can also be used

Note: Micro Memory Card required for operation of CPU.

Note:

SIPLUS extreme products are based on Siemens Industry standard products. The contents listed here were taken from the respective standard products. SIPLUS extreme-specific information was added.

SIPLUS IM 151-7 F-CPU Standard interface module	
Order No.	6AG1 151-7FA21-2AB0
Order number based on	6ES7 151-7FA21-0AB0
Ambient temperature range	-25 ... +60 °C
Conformal coating	Coating of the printed circuit boards and the electronic components
Technical data	The technical data of the standard product applies except for the ambient conditions.

Ambient conditions

Relative humidity	100%, condensation/frost permissible. No commissioning if condensation present.
-------------------	---

Technical documentation on SIPLUS can be found here:
<http://www.siemens.com/siplus-extreme>

Ordering data	Order No.
SIPLUS IM 151-7 F-CPU interface module (extended temperature range and medial exposure) For configuring a fail-safe automation system	6AG1 151-7FA21-2AB0
Accessories	See SIMATIC IM151-7 F-CPU interface module, page 9/52

SIMATIC ET 200 distributed I/O

ET 200S

SIPLUS interface modules with fail-safe CPU SIPLUS IM 151-8 F PN/DP CPU

Overview



- Interface module for SIPLUS ET 200S with integrated CPU S7-314
- For high-performance control solutions in ET 200S
- Increases the availability of plants and machinery
- PROFINET IO Controller for up to 128 IO-Devices
- PROFINET I-Device for connecting the CPU as an intelligent PROFINET device with a SIMATIC or third-party PROFINET I/O Controller
- PROFINET interface with integrated 3-port switch
- Isochronous mode on PROFINET
- With multiple communication options: PG/OP communication, PROFINET IO, PROFINET CBA, open IE communication (TCP, ISO-on-TCP and UDP), Web server and S7 communication (with loadable FBs)
- Fast, simple and uniform programming of a system with modular programs via STEP 7
- Compact SIMATIC Micro Memory Card (MMC)
- Optional PROFIBUS master for 32 PROFIBUS DP slaves (with master interface 6ES7138-4HA00-0AB0)
- Fail-safe IM 151-8F PN/DP CPU PROFIsafe available

SIMATIC Micro Memory Card required for operation of CPU.

Note:

SIPLUS extreme products are based on Siemens Industry standard products. The contents listed here were taken from the respective standard products. SIPLUS extreme specific information was added.

SIPLUS IM 151-8 F PN/DP CPU

Order No.	6AG1 151-8FB01-2AB0
Order number based on	6ES7 151-8FB01-0AB0
Ambient temperature range	-25 ... +60 °C
Conformal coating	Coating of the printed circuit boards and the electronic components
Technical data	The technical data of the standard product applies except for the ambient conditions.
Ambient conditions:	
Relative humidity	100%, condensation/frost permissible. No commissioning if condensation present.

For technical documentation on SIPLUS, see:
<http://www.siemens.com/siplus-extreme>

Ordering data

Order No.

SIPLUS interface module IM 151-8F PN/DP CPU	6AG1 151-8FB01-2AB0
(extended temperature range and medial exposure)	
Including termination module	
Accessories	See SIMATIC IM 151-8F PN/DP CPU interface module, page 9/55

SIMATIC ET 200 distributed I/O

ET 200S

Interface modules without CPU IM 151-1

Overview



- Interface module for linking the ET 200S to PROFIBUS DP
- Handles all data exchange with the PROFIBUS DP master
- 6 variants:
 - IM151-1 BASIC (RS485)
 - IM151-1 COMPACT 32DI DC24V (RS485)
 - IM151-1 COMPACT 16DI DC24V / 16DO DC24V/0.5A (RS485)
 - IM151-1 STANDARD (RS485)
 - IM151-1 STANDARD (FO)
 - IM151-1 HIGH FEATURE (RS485)
- Delivery including connection module

The main differences between the IM151-1 variants:

	IM151-1 BASIC	IM151-1 COMPACT	IM151-1 STANDARD	IM151-1 FO STANDARD	IM151-1 HIGH FEATURE
Order number 6ES7 151-	1CA00-0AB0	1CA00-1BL00 1CA00-3BL00	1AA05-0AB0	1AB05-0AB0	1BA02-0AB0
Integral I/O	-	32 DI 16DI / 16 DO	-	-	-
Maximal number of I/O modules	12	12	63	63	63
Maximum station width	2 m	2 m	2 m	1 m	2 m
Maximal number of parameters	198 bytes	218 bytes	244 bytes	244 bytes	244 bytes
Maximum address space for inputs and outputs	88 bytes each	100 bytes each	244 bytes	128 bytes	Depending on the DP master: 244 bytes or not relevant
Maximum diagnostics length	6 to 43 bytes	6 to 44 bytes	6 to 122 bytes	6 to 64 bytes	6 to 128 bytes
Protocol	DP V0	DP V0	DP V0 and DP V1	DP V0	DP V0 and DP V1
DP connection type	RS485	RS485	RS485	Fiber-optic cable	RS485
Firmware update	No	No	Yes	No	Yes
Option handling	No	No	Yes	Yes	Yes
Isochronous mode	No	No	No	No	Yes
Maximum address volume per module	8 bytes	8 bytes	32 bytes	8 bytes	32 bytes
Identification data	No	No	Yes	No	Yes
Use of fail-safe modules (PROFIsafe)	No	No	No	No	Yes
I-slave-to-slave communication	No	No	No	No	Yes

Technical specifications

	6ES7 151-1AA04-0AB0	6ES7 151-1AB05-0AB0	6ES7 151-1BA02-0AB0	6ES7 151-1CA00-0AB0
General information				
Vendor identification (VendorID)	806Ah	806Bh		80F3h
Supply voltage				
Mains buffering				
• Mains buffering, min.	20 ms	20 ms	20 ms	No
Input current				
from supply voltage 1L+, max.	200 mA	200 mA	200 mA	70 mA
Output current				
Current output to backplane bus (DC 5 V), max.		700 mA		
Power losses				
Power loss, typ.	3.3 W	3.3 W	3.3 W	1.5 W
Address area				
Addressing volume				
• Outputs	244 byte	244 byte	244 byte	88 byte
• Inputs	244 byte	244 byte	244 byte	88 byte
Interfaces				
Interface physics, RS 485	Yes; 9-pin sub D socket		Yes	Yes; 9-pin sub D socket
Interface physics, FOC		Yes; 4 x Simplex socket		
PROFIBUS DP				
• Cable length, max.	1 200 m	2 m		
• PROFIBUS DP, output current, max.	80 mA			80 mA
• Transmission rate, max.	12 Mbit/s; 9.6 / 19.2 / 45.45 / 93.75 / 187.5 / 500 Kbit/s; 1.5 / 3 / 6 / 12 Mbit/s	12 Mbit/s; 9.6 / 19.2 / 45.45 / 93.75 / 187.5 / 500 Kbit/s; 1.5 / 12 Mbit/s	12 Mbit/s	12 Mbit/s; 9.6 / 19.2 / 45.45 / 93.75 / 187.5 / 500 Kbit/s; 1.5 / 3 / 6 / 12 Mbit/s
• SYNC capability	Yes	Yes	Yes	Yes
• FREECE capability	Yes	Yes	Yes	Yes
• Direct data exchange (slave-to-slave communication)	Yes	Yes	Yes	Yes
Protocols				
PROFIBUS DP	Yes	Yes	Yes	Yes
Isochronous mode				
Isochronous operation (application synchronized up to terminal)	No	No	Yes	No
Interrupts/diagnostics/status information				
Alarms				
• Alarms	Yes	Yes	Yes	No
Diagnostic messages				
• Diagnostic functions	Yes	Yes	Yes	Yes
Diagnostics indication LED				
• Bus fault BF (red)	Yes	Yes	Yes	Yes
• Group error SF (red)	Yes	Yes	Yes	Yes
• Monitoring 24 V voltage supply ON (green)	Yes	Yes	Yes	Yes
Galvanic isolation				
between backplane bus and electronics	No	No	No	No
between electronic block and PROFIBUS DP	Yes		Yes	Yes
between supply voltage and electronics	No	No	No	No
Permissible potential difference				
between different circuits	75 VDC / 60 VAC	500 V DC	75 VDC / 60 VAC	75 VDC / 60 VAC

SIMATIC ET 200 distributed I/O

ET 200S

Interface modules without CPU IM 151-1

Technical specifications (continued)

	6ES7 151-1AA04-0AB0	6ES7 151-1AB05-0AB0	6ES7 151-1BA02-0AB0	6ES7 151-1CA00-0AB0
Isolation				
Isolation checked with	500 V DC	57 V DC / 60 V AC	500 V DC	500 V DC
Dimensions				
Width	45 mm	45 mm	45 mm	45 mm
Height	119.5 mm	119.5 mm	119.5 mm	119.5 mm
Depth	75 mm	75 mm	75 mm	75 mm
Weight				
Weight, approx.	150 g	150 g	150 g	150 g

	6ES7 151-1CA00-1BL0	6ES7 151-1CA00-3BL0
General information		
Vendor identification (VendorID)		8200H
Supply voltage		
Rated value (DC)	24 V	24 V
Reverse polarity protection	Yes	Yes
Input current		
from supply voltage 1L+, max.	100 mA; 100	100 mA
Address area		
Addressing volume		
• Outputs	100 byte	100 byte
• Inputs	100 byte	100 byte
Digital inputs		
Number/binary inputs	32	16
Input voltage		
• Type of input voltage	DC	DC
• Rated value, DC	24 V	24 V
• for signal "0"	-30 to +5 V	-30 to +5 V
• for signal "1"	13 to 30 V	13 to 30 V
Input current		
• for signal "1", typ.	4 mA; At 24 V min. 2 mA	3 mA
Input delay (for rated value of input voltage)		
• for standard inputs		
- at "0" to "1", min.	3 ms	3 ms
- at "0" to "1", max.	3 ms	3 ms
Cable length		
• Cable length unshielded, max.	1 000 m	1 000 m
Digital outputs		
Number/binary outputs	0	16
Functionality/short-circuit strength		Yes
Limitation of inductive shutdown voltage to		L+ (-55 to -60 V)
Lamp load, max.		5 W
Controlling a digital input		Yes
Output current		
• for signal "1" permissible range for 0 to 60 °C, min.		7 mA
• for signal "0" residual current, max.		0.5 mA
Output delay with resistive load		
• "0" to "1", max.		0.5 ms
• "1" to "0", max.		1.3 ms
Switching frequency		
• with resistive load, max.		100 Hz
• with inductive load, max.		2 Hz
• on lamp load, max.		10 Hz
Aggregate current of outputs (per group)		
• all mounting positions - up to 60 °C, max.		2 A
Cable length		
• Cable length unshielded, max.		1 000 m

Technical specifications (continued)

	6ES7 151-1CA00-1BL0	6ES7 151-1CA00-3BL0
Encoder		
Connectable encoders		
• 2-wire sensor - Permissible quiescent current (2-wire sensor), max.		Yes 1.5 mA
Interfaces		
Interface physics, RS 485	Yes	Yes
Interface physics, FOC	No	No
Supports protocol for PROFINET IO		
• Transmission rate, max.		12 Mbit/s
PROFIBUS DP		
• Cable length, max.	1 200 m	1 200 m
• PROFIBUS DP, output current, max.		80 mA
• Transmission procedure	RS 485	RS 485
• Direct data exchange (slave-to-slave communication)	Yes	Yes
Protocols		
Supports protocol for PROFINET IO	No	No
PROFIBUS DP	Yes	Yes
Protocols (Ethernet)		
• TCP/IP	No	No
Isochronous mode		
Isochronous operation (application synchronized up to terminal)	No	No
Interrupts/diagnostics/ status information		
Alarms		
• Alarms	No	No
Diagnostic messages		
• Diagnostic functions	Yes	Yes
Diagnostics indication LED		
• Run mode RUN (green)	Yes	Yes
• Group error SF (red)		Yes
• Status indicator digital output (green)		Yes
• Status indicator digital input (green)		Yes
• Monitoring 24 V voltage supply ON (green)	Yes	Yes
• Connection to network LINK (green)		No
• Transmit/receive RX/TX (yellow)		No
Galvanic isolation		
between backplane bus and electronics		No
between supply voltage and electronics		No
Galvanic isolation digital inputs		
• Galvanic isolation digital inputs		No
Galvanic isolation digital outputs		
• Galvanic isolation digital outputs		Yes
Isolation		
Isolation checked with	500 V DC	500 V DC
Degree and class of protection		
IP20	Yes	Yes
Connection method		
Inputs/outputs		Screw-type and spring-loaded terminals, permanent wiring; 3 and 4-wire connection
Dimensions		
Width	120 mm	120 mm
Height	81 mm	81 mm
Depth	758 mm; 58	58 mm
Weight		
Weight, approx.		230 g; EB only

SIMATIC ET 200 distributed I/O

ET 200S

Interface modules without CPU

IM 151-1

Ordering data	Order No.	Order No.
IM 151-1 BASIC interface module for ET 200S; transfer rates up to 12 Mbit/s; max. 12 power, electronic and motor start modules can be connected; bus connection via 9-pin sub D incl. termination module	6ES7151-1CA00-0AB0	Accessories TM-C120S terminal module Terminal module for ET 200S COMPACT, screw-type terminals
IM 151-1 COMPACT 32 DI 24 V DC interface module for ET 200S; transfer rates up to 12 Mbit/s; max. 32 digital inputs, can be expanded by max. 12 power, electronic and motor start modules; bus connection via 9-pin sub D incl. termination module	6ES7151-1CA00-1BL0	TM-C120C terminal module Terminal module for ET 200S COMPACT, spring-loaded terminals
IM 151-1 COMPACT 16 DI 24 V DC / 16 DO 24 V/0.5 A interface module for ET 200S; transfer rates up to 12 Mbit/s; max. 16 digital inputs and 16 digital outputs, can be expanded by max. 12 power, electronic and motor start modules; bus connection via 9-pin sub D incl. termination module	6ES7151-1CA00-3BL0	TE-U120S4x10 add-on terminal Add-on terminal for TM-C120x terminal modules of ET 200S COMPACT; screw-type terminals for 3-wire connection; please order two for 4-wire connection Can also be attached to TM-E/TM-P, provided at least 120 mm of the construction width attains the same overall height as the terminal module
IM 151-1 STANDARD interface module for ET 200S; transfer rates up to 12 Mbit/s; data volumes 244 bytes each for inputs and outputs, max. 63 power, electronic and motor start modules can be connected; bus connection via 9-pin sub D incl. termination module	6ES7151-1AA05-0AB0	TE-U120C4x10 add-on terminal Add-on terminal for TM-C120x terminal modules of ET 200S COMPACT; spring-loaded terminals for 3-wire connection; please order two for 4-wire connection Can also be attached to TM-E/TM-P, provided at least 120 mm of the construction width attains the same overall height as the terminal module
IM 151-1 FO STANDARD interface module for ET 200S, transfer rates up to 12 Mbit/s; data volumes 244 bytes each for inputs and outputs; max. 63 power, electronic and starter modules can be connected; bus connection via integrated fiber-optic cable incl. termination module	6ES7151-1AB05-0AB0	ET 200S distributed I/O system manuals are available on the Internet as PDF files: www.siemens.com/simatic-docu
IM 151-1 HIGH FEATURE interface module for ET 200S; transfer rate up to 12 Mbit/s; data volumes 244 bytes each for I/O, up to 63 modules can be connected; connection of PROFI-safe modules, isochronous mode; bus connection via 9-pin sub D incl. termination module	6ES7151-1BA02-0AB0	SIMATIC Manual Collection Electronic manuals on DVD, multi-language: S7-200, TD 200, S7-300, M7-300, C7, S7-400, M7-400, STEP 7, Engineering Tools, Runtime Software, SIMATIC DP (Distributed I/O), SIMATIC HMI (Human Machine Interface), SIMATIC NET (Industrial Communication)
		SIMATIC Manual Collection – Update service for 1 year Scope of delivery: Current DVD "S7 Manual Collection" and the three subsequent updates

SIMATIC ET 200 distributed I/O

ET 200S

Interface modules without CPU
IM 151-1

Ordering data	Order No.	Ordering data	Order No.
PROFIBUS DP bus connector RS 485 With 90° cable outlet for FastConnect connection system, max. transfer rate 12 Mbit/s Without PG interface <ul style="list-style-type: none"> • 1 unit • 100 units With PG interface <ul style="list-style-type: none"> • 1 unit • 100 units 	6ES7 972-0BA52-0XA0 6ES7 972-0BA52-0XB0	Label sheets DIN A4 (10 pieces) Can be used for ET 200S COMPACT. Each sheet has 10 labeling strips <ul style="list-style-type: none"> • beige • yellow • red • petrol 	6ES7 193-4BA10-0AA0 6ES7 193-4BB10-0AA0 6ES7 193-4BD10-0AA0 6ES7 193-4BH10-0AA0
100 Simplex connectors For plastic fiber-optic cable incl. 5 polishing sets	6GK1 901-0FB00-0AA0	Termination module as spare part for ET 200S	6ES7 193-4JA00-0AA0
50 plug adapters For 2 Simplex connectors each	6ES7 195-1BE00-0XA0	Power supply connector Spare part; for connecting the 24 V DC supply voltage <ul style="list-style-type: none"> • with push-in terminals • with screw-type terminals 	6ES7 193-4JB00-0AA0 6ES7 193-4JB50-0AA0
Label sheets DIN A4 (10 pieces) Each sheet contains 60 labeling strips for peripheral modules and 20 labeling strips for interface modules <ul style="list-style-type: none"> • petrol • red • yellow • light beige 	6ES7 193-4BH00-0AA0 6ES7 193-4BD00-0AA0 6ES7 193-4BB00-0AA0 6ES7 193-4BA00-0AA0	SIMATIC S5, 35 mm DIN rail <ul style="list-style-type: none"> • Length: 483 mm for 19" cabinets • Length: 530 mm for 600 mm cabinets • Length: 830 mm for 900 mm cabinets • 2 m long 	6ES5 710-8MA11 6ES5 710-8MA21 6ES5 710-8MA31 6ES5 710-8MA41

SIMATIC ET 200 distributed I/O

ET 200S

Interface modules without CPU

IM 151-3 PN

Overview



- Interface module for linking the ET 200S to PROFINET
- Handles all data exchange with the PROFINET I/O Controller
- 3 versions:
 - IM151-3 PN STANDARD
 - IM151-3 PN HIGH FEATURE and IM 151-3 PN FO: supports, in contrast to the STANDARD version, the operation of PROFI-safe F modules
- with integrated 2-port switch for line topology
- Delivery including connecting module

Note:

Micro Memory Card required for operation depending on the configuration.

Technical specifications

	6ES7 151-3AA23-0AB0	6ES7 151-3BA23-0AB0
Supply voltages		
Supply voltage of electronics 1L+		
• Rated value (DC)	24 V	24 V
• Reverse polarity protection	Yes	Yes
Mains/voltage failure jumpering, min.	20 ms	20 ms
Current consumption		
from supply voltage 1L+, max.	250 mA	250 mA
Current consumption/power loss		
Power loss, typ.	2.5 W	2.5 W
Address area		
Addressing volume		
• Outputs	256 byte	256 byte
• Inputs	256 byte	256 byte
Interfaces		
Automatic detection of transmission speed	Yes	Yes
Connection point		
RJ45	Yes	Yes
Protocols		
PROFINET IO	Yes	Yes
PROFINET IO		
Transmission speed, max.	100 MBit/s	100 MBit/s
Isochronous mode		
Isochronous mode	Yes	Yes
Status information/alarms/diagnostics		
Alarms		
• Alarms	Yes	Yes
Diagnostics		
• Diagnostic functions	Yes	Yes
Diagnostic indication LED		
• Bus error BF (red)	Yes	Yes
• Collective error SF (red)	Yes	Yes
• Monitoring 24 V voltage supply ON (green)	Yes	Yes
• Connection to network LINK (green)	Yes	Yes
• Maintenance (yellow)	Yes	Yes

Technical specifications (continued)

	6ES7 151-3AA23-0AB0	6ES7 151-3BA23-0AB0
Galvanic isolation		
between backplane bus and electronics	No	No
between supply voltage and electronics	No	No
between Ethernet and electronics	Yes	Yes
General information		
Vendor identification (VendorID)	002AH	002AH
Device identifier (DeviceID)	0301	0301H
Dimensions		
Dimensions		
• Width	60 mm	60 mm
• Height	119.5 mm	119.5 mm
• Depth	75 mm	75 mm
Weights		
• Weight, approx.	120 g	135 g

Ordering data

	Order No.		Order No.
IM 151-3 PN interface module for ET 200S; transfer rates up to 100 Mbit/s; data volume depends on the number of modules inserted, up to 63 modules can be connected, bus connection through RJ45	6ES7 151-3AA23-0AB0	Industrial Ethernet FastConnect installation cables Fast Connect standard cable Fast Connect trailing cable Fast Connect marine cable	6XV1 840-2AH10 6XV1 840-3AH10 6XV1 840-4AH10
IM 151-3 PN PROFINET High Feature interface module for ET 200S; transfer rate up to 100 Mbit/s; max. 63 modules up to 2 m wide can be connected; bus connection via RJ45, incl. termination module	6ES7 151-3BA23-0AB0	Termination Kits SC RJ POF Plug Assembly case for on-site assembly of SC RJ plugs consisting of stripping tool, kevlar cutter, microscope, abrasive paper, grinding support IE SC RJ POF Plug Screw-in plug for on-site assembly to POF fiber optic cable (1 pack = 20 units) IE SC RJ Refill Set POF Refill set for Termination Kit SC RJ POF Plug, consisting of abrasive paper and grinding plate (set of 5)	6GK1 900-0ML00-0AA0 6GK1 900-0MB00-0AC0 6GK1 900-0MN00-0AA0
IM 151-3 FO interface module for ET 200S; with 2 PROFINET FO-interfaces and integrated 2-port switch, max. 63 modules up to 2 m wide can be connected, incl. termination module	6ES7 151-3BB23-0AB0	SC RJ POF Plug Assembly case for on-site assembly of SC RJ plugs consisting of stripping tool, buffer stripping tool, kevlar cutter, fiber breaking tool, microscope Industrial Ethernet SC RJ PCF Plug Screw-in plug for on-site assembly to PCF fiber optic cable (1 pack = 10 units)	6GK1 900-0NL00-0AA0 6GK1 900-0NB00-0AC0
Accessories			
Industrial Ethernet FC RJ45 Plug 90 RJ45 plug connector for Industrial Ethernet with a rugged metal enclosure and integrated insulation displacement contacts for connecting Industrial Ethernet FC installation cables; with 90° cable outlet 1 unit 10 units 50 units	6GK1 901-1BB20-2AA0 6GK1 901-1BB20-2AB0 6GK1 901-1BB20-2AE0		

SIMATIC ET 200 distributed I/O

ET 200S

Interface modules without CPU IM 151-3 PN

Ordering data	Order No.	Order No.
Industrial Ethernet Fast Connect stripping tool	6GK1 901-1GA00	
MMC 64 KB ¹⁾ For storing the device name	6ES7 953-8LF20-0AA0	
MMC 128 KB ¹⁾ For storing the device name	6ES7 953-8LG20-0AA0	
MMC 512 KB ¹⁾ For storing the device name	6ES7 953-8LJ30-0AA0	
MMC 2 MB ¹⁾ For storing the device name and/or firmware update	6ES7 953-8LL31-0AA0	
MMC 4 MB ¹⁾ For storing the device name and/or firmware update	6ES7 953-8LM20-0AA0	
MMC 8 MB ¹⁾ For storing the device name and/or firmware update	6ES7 953-8LP20-0AA0	
ET 200S distributed I/O system manuals are available on the Internet as PDF files: www.siemens.com/simatic-docu		
SIMATIC Manual Collection Electronic manuals on DVD, multi-language: S7-200, TD 200, S7-300, M7-300, C7, S7-400, M7-400, STEP 7, Engineering Tools, Runtime Software, SIMATIC DP (Distributed I/O), SIMATIC HMI (Human Machine Interface), SIMATIC NET (Industrial Communication)	6ES7 998-8XC01-8YE0	
SIMATIC Manual Collection – Update service for 1 year Scope of delivery: Current DVD "S7 Manual Collection" and the three subsequent updates	6ES7 998-8XC01-8YE2	
		Label sheets DIN A4 (10 pieces) Each sheet contains 60 labeling strips for peripheral modules and 20 labeling strips for interface modules • petrol • red • yellow • light beige 6ES7 193-4BH00-0AA0 6ES7 193-4BD00-0AA0 6ES7 193-4BB00-0AA0 6ES7 193-4BA00-0AA0
		Termination module as spare part for ET 200S 6ES7 193-4JA00-0AA0
		Power supply connector Spare part; for connecting the 24 V DC supply voltage • with push-in terminals • with screw-type terminals 6ES7 193-4JB00-0AA0 6ES7 193-4JB50-0AA0
		DIN rail 35 mm • Length: 483 mm for 19" cabinets • Length: 530 mm for 600 mm cabinets • Length: 830 mm for 900 mm cabinets • Length: 2 m 6ES5 710-8MA11 6ES5 710-8MA21 6ES5 710-8MA31 6ES5 710-8MA41
		Industrial Ethernet Switches Managed Industrial Ethernet Switches; Isochronous real time, LED diagnostics, fault signaling contact with SET button, redundant power supply • SCALANCE X202-2P IRT; 2 x 10/100 Mbit/s RJ45 ports, 2 x 100 Mbit/s POF/PCF SC RJ 6GK5 202-2BH00-2BA3 • SCALANCE X201-3P IRT; 1 x 10/100 Mbit/s RJ45 ports, 3 x 100 Mbit/s POF/PCF SC RJ 6GK5 201-3BH00-2BA3 • SCALANCE X200-4P IRT; 4 x 100 Mbit/s POF/PCF SC RJ 6GK5 200-4AH00-2BA3

¹⁾ For operating the IM 151-3, an MMC is essential

SIPLUS interface modules without CPU
SIPLUS IM 151-1

Overview



- Interface module for linking the ET 200S to PROFIBUS DP
- Handles all data exchange with the PROFIBUS DP master

Note:

SIPLUS extreme products are based on Siemens Industry standard products. The contents listed here were taken from the respective standard products. SIPLUS extreme specific information was added.

	SIPLUS IM 151-1 Standard	SIPLUS IM 151-1 High Feature
Order No.	6AG1 151-1AA05-7AB0	6AG1 151-1BA02-2AB0
Order number based on	6ES7 151-1AA05-0AB0	6ES7 151-1BA02-0AB0
Ambient temperature range	-25 ... +70 °C	-25 ... +60 °C
Conformal coating	Coating of the printed circuit boards and the electronic components	
Technical data	The technical data of the standard product applies except for the ambient conditions.	
Ambient conditions		
Relative humidity	100%, condensation/frost permissible. No commissioning if condensation present.	
Biologically active substances, compliance with EN 60721-3-3	Class 3B2 mold and fungal spores (excluding fauna). The supplied plug covers must remain in place over the unused interfaces during operation!	
Chemically active substances, compliance with EN 60721-3-3	Class 3C4 incl. salt spray in accordance with EN60068-2-52 (degree of severity 3). The supplied plug covers must remain in place over the unused interfaces during operation!	
Mechanically active substances, compliance with EN 60721-3-3	Class 3S4 incl. sand, dust. The supplied plug covers must remain in place over the unused interfaces during operation!	
Air pressure (depending on the highest positive temperature range specified)	1 080 ... 795 hPa (-1 000 ... +2 000 m) see ambient temperature range 795 ... 658 hPa (+2 000 ... +3 500 m) derating 10 K 658 ... 540 hPa (+3 500 ... +5 000 m) derating 20 K	

For technical documentation on SIPLUS, see:
<http://www.siemens.com/siplus-extreme>

Ordering data	Order No.
SIPLUS IM 151-1 STANDARD interface module (extended temperature range and medial exposure) for ET 200S; transfer rates up to 12 Mbit/s; data volumes 244 bytes each for inputs and outputs, max. 63 power, electronic and motor start modules can be connected; bus connection via 9-pin D-sub incl. termination module	6AG1 151-1AA05-7AB0
SIPLUS IM 151-1 HIGH FEATURE interface module (extended temperature range and medial exposure) for ET 200S; transfer rate up to 12 Mbit/s; data volumes 244 bytes each for inputs and outputs, up to 63 modules can be connected; connection of PROFIsafe modules, isochronous mode (clock synchronization); bus connection via 9-pin Sub-D incl. terminating module	6AG1 151-1BA02-2AB0
Accessories	See SIMATIC IM 151-1, page 9/62

SIMATIC ET 200 distributed I/O

ET 200S

SIPLUS interface modules without CPU
SIPLUS IM 151-3PN

Overview



- Interface module for interface to ET 200S PROFINET
- Handles all data exchange with the PROFINET I/O controller
- IM 151-3 PN STANDARD
- With integrated 2-port switch for line topology

Micro Memory Card required for operation of CPU.

Note:

SIPLUS extreme products are based on Siemens Industry standard products. The contents listed here were taken from the respective standard products. SIPLUS extreme specific information was added.

SIPLUS IM 151-3 PN

Order No.	6AG1 151-3AA23-2AB0	6AG1 151-3BA23-7AB0
Order number based on	6ES7 151-3AA23-0AB0	6ES7 151-3BA23-0AB0
Ambient temperature range	-25 ... +60 °C	-25 ... +70 °C
Conformal coating	Coating of the printed circuit boards and the electronic components	
Technical data	The technical data of the standard product applies except for the ambient conditions.	

Ambient conditions

Relative humidity	100%, condensation/frost permissible. No commissioning if condensation present.
Biologically active substances, compliance with EN 60721-3-3	Class 3B2 mold and fungal spores (excluding fauna). The supplied plug covers must remain in place over the unused interfaces during operation!
Chemically active substances, compliance with EN 60721-3-3	Class 3C4 incl. salt spray in accordance with EN60068-2-52 (degree of severity 3). The supplied plug covers must remain in place over the unused interfaces during operation!
Mechanically active substances, compliance with EN 60721-3-3	Class 3S4 incl. sand, dust. The supplied plug covers must remain in place over the unused interfaces during operation!
Air pressure (depending on the highest positive temperature range specified)	1 080 ... 795 hPa (-1 000 ... +2 000 m) see ambient temperature range 795 ... 658 hPa (+2 000 ... +3 500 m) derating 10 K 658 ... 540 hPa (+3 500 ... +5 000 m) derating 20 K

For technical documentation on SIPLUS, see:
<http://www.siemens.com/siplus-extreme>

Ordering data

SIPLUS IM 151-3 PN interface module

(extended temperature range and medial exposure)

For ET 200S; transfer rates up to 100 Mbit/s; data volume depends on the number of modules inserted, up to 63 modules can be connected, bus connection through RJ45

Order No.

6AG1 151-3AA23-2AB0

SIPLUS IM 151-3 PN PROFINET High Feature interface module

(extended temperature range and medial exposure)

for ET 200S; transfer rate up to 100 Mbit/s; max. 63 modules up to 2 m wide can be connected; bus connection via RJ45, incl. termination module

6AG1 151-3BA23-7AB0

Accessories

See SIMATIC IM 151-3 PN interface module, page 9/65

Overview



- For monitoring and, depending on the version, fusing the load and sensor supply voltage
- Can be plugged onto TM-P terminal modules with automatic coding.
- Diagnostics message for voltage and blown fuse (can be switched off via configuration)
- PM-E 24 V DC Standard
 - load voltage diagnostics
- PM-E 24 V DC High Feature
 - load voltage and reverse voltage diagnostics
 - with status information
 - option handling (only in combination with the IM 151-1 Standard, IM 151-1 FO Standard and IM 151-1 High Feature)
- 24 to 48 V DC PM-E power module
 - load voltage diagnostics
 - with status information
 - option handling (only in combination with the IM 151-1 Standard, IM 151-1 FO Standard and IM 151-1 High Feature)
- PM-E 24 V DC to 230 V AC power module
 - power module for universal use
 - with integral replaceable fuse
 - with status information
 - option handling (only in combination with the IM 151-1 Standard, IM 151-1 FO Standard and IM151-1 High Feature)

Technical specifications

	6ES7 138-4CA01-0AA0	6ES7 138-4CB11-0AB0
Supply voltage		
Load voltage L+		
• Rated value (DC)	24 V	
• Short-circuit protection	No; external (e.g. automatic circuit breaker), tripping characteristic C	
• Reverse polarity protection	Yes	
Input current		
from load voltage 1L+ (without load), max.	4 mA	
Current carrying capacity		
Current carrying capacity up to 60 °C, max.	10 A	
Power losses		
Power loss, typ.	0.1 W	
Interrupts/diagnostics/ status information		
Diagnostic messages		
• Diagnostics	Yes	
• Missing load voltage	Yes	
Diagnostics indication LED		
• Rated load voltage PWR (green)	Yes	
• Group error SF (red)	Yes	
Parameter		
Remark	3 bytes	
Missing load voltage	Disable / enable	
Galvanic isolation		
primary/secondary	Yes; between rated load voltage and backplane bus, between power modules	
Isolation		
Isolation checked with	500 V DC	
Dimensions		
Width	15 mm	15 mm
Height	81 mm	81 mm
Depth	52 mm	52 mm
Weight		
Weight, approx.	35 g	

SIMATIC ET 200 distributed I/O

ET 200S

I/O modules

Power modules for PM-E electronic modules

Technical specifications (continued)

6ES7 138-4CA50-0AB0 PM-E 24 to 48 V DC	
Supply voltage Load voltage L+ • Rated values • Short-circuit protection • Reverse polarity protection	24 to 48 V DC No; external (e.g. automatic circuit breaker), tripping characteristic B, C Yes
Input current from load voltage 1L+ (without load), max.	12 mA
Current carrying capacity Current carrying capacity up to 60 °C, max.	10 A
Power losses Power loss, typ.	500 W; mW
Interrupts/diagnostics/ status information Diagnostic messages • Diagnostics • Missing load voltage	Yes Yes

6ES7 138-4CA50-0AB0 PM-E 24 to 48 V DC	
Diagnostics indication LED • Rated load voltage PWR (green) • Group error SF (red)	Yes Yes
Parameter Remark	3 bytes
Missing load voltage	Disable / enable
Galvanic isolation primary/secondary	Yes; between rated load voltage and backplane bus, between power modules
Isolation Isolation checked with	500 V DC
Dimensions Width	15 mm
Height	81 mm
Depth	52 mm
Weight Weight, approx.	35 g

Ordering data

Ordering data	Order No.
PM-E 24 V DC Standard power module ¹⁾ For electronic modules; with diagnostics 1 unit 5 units	6ES7 138-4CA01-0AA0 6ES7 138-4CA01-1AA0
PM-E 24 V DC High Feature power module ¹⁾ For electronic modules; with diag- nostics	6ES7 138-4CA60-0AB0
24 to 48 V DC PM-E power module For electronic modules; with diagnostics, with status bit "load voltage" present 1 unit 5 units	6ES7 138-4CA50-0AB0 6ES7 138-4CA50-1AB0
Power module PM-E 24 V DC to 48 V, 42 to 230 V AC For electronic modules; with diagnostics and fuse	6ES7 138-4CB11-0AB0

Accessories

Label sheets DIN A4 (10 pieces)

Each sheet contains 60 labeling
strips for peripheral modules and
20 labeling strips for interface
modules

- petrol
- red
- yellow
- light beige

Order No.

6ES7 193-4BH00-0AA0
6ES7 193-4BD00-0AA0
6ES7 193-4BB00-0AA0
6ES7 193-4BA00-0AA0

¹⁾ Can be used for all electronic and technology modules except
2 DI 120 V AC / 2 DI 230 V AC / 2 DO 120/230 V AC

Selection tool for terminal modules

Power modules	TM-P terminal modules for power modules			
Screw-type terminal type designation	TM-P15S23-A1	TM-P15S23-A0	TM-P15S22-01	TM-P30S44-A0
Order number 6ES7 193...	4CC20-0AA0	4CD20-0AA0	4CE00-0AA0	4CK20-0AA0
Spring-loaded terminal type designation	TM-P15C23-A1	TM-P15C23-A0	TM-P15C22-01	TM-P30C44-A0
Order number 6ES7 193...	4CC30-0AA0	4CD30-0AA0	4CE10-0AA0	4CK30-0AA0
FastConnect type designation	TM-P15N23-A1	TM-P15N23-A0	TM-P15N22-01	Soon to come
Order number 6ES7 193...	4CC70-0AA0	4CD70-0AA0	4CE60-0AA0	
PM-E 24 V DC	•	•	•	
PM-E 24 V DC to 48 V DC	•	•	•	
PM-E 24 V DC/120/230 V AC	•	•	•	
PM-E F 24 V DC PROFIsafe				•

Overview



- For monitoring and, depending on the version, fusing the load and sensor supply voltage
- Can be plugged onto TM-P terminal modules with automatic coding
- Diagnostics message for voltage and blown fuse (can be switched off via configuration)
- Fail-safe PM-E F PROFIsafe power module for safely switching off sequentially plugged-in 24 V DC to 10 A digital output modules or external loads; 3 additional integrated fail-safe 24 V DC/2 A outputs
- PM-E 24 V DC to 48 V DC
 - with status information and diagnostics "Load voltage present"
 - for option handling
- PM-E 24 V DC to 230 V AC power module
 - power module for universal use
 - for option handling

Note:

SIPLUS extreme products are based on Siemens Industry standard products. The contents listed here were taken from the respective standard products. SIPLUS extreme specific information was added.

PM-E 24 V DC power module	
Order No.	6AG1 138-4CA01-2AA0
Order number based on	6ES7 138-4CA01-0AA0
Ambient temperature range	-40 ... +70 °C
Ambient conditions	Suited for exceptional medial exposure (e.g. by chlorine sulfur atmosphere).
Technical data	The technical data are identical with those of the based-on modules.

24 to 48 V DC PM-E power module	
Order No.	6AG1 138-4CA50-2AB0
Order number based on	6ES7 138-4CA50-0AB0
Ambient temperature range	-25 ... +60 °C
Ambient conditions	Suited for exceptional medial exposure (e.g. by chlorine sulfur atmosphere).
Technical data	The technical data are identical with those of the based-on modules.

Power module PM-E 24 to 48 V DC/42 to 230 V AC	
Order No.	6AG1 138-4CB11-2AB0
Order number based on	6ES7 138-4CB11-0AB0
Ambient temperature range	-25 ... +60 °C
Ambient conditions	Suited for exceptional medial exposure (e.g. by chlorine sulfur atmosphere).
Technical data	The technical data are identical with those of the based-on modules.

Ambient conditions	
Relative humidity	100%, condensation/frost permissible. No commissioning if condensation present.
Biologically active substances, compliance with EN 60721-3-3	Class 3B2 mold and fungal spores (excluding fauna). The supplied plug covers must remain in place over the unused interfaces during operation!
Chemically active substances, compliance with EN 60721-3-3	Class 3C4 incl. salt spray in accordance with EN60068-2-52 (degree of severity 3). The supplied plug covers must remain in place over the unused interfaces during operation!
Mechanically active substances, compliance with EN 60721-3-3	Class 3S4 incl. sand, dust. The supplied plug covers must remain in place over the unused interfaces during operation!
Air pressure (depending on the highest positive temperature range specified)	1 080 ... 795 hPa (-1 000 ... +2 000 m) see ambient temperature range 795 ... 658 hPa (+2 000 ... +3 500 m) derating 10 K 658 ... 540 hPa (+3 500 ... +5 000 m) derating 20 K

For technical documentation on SIPLUS, see:
<http://www.siemens.com/siplus-extreme>

SIMATIC ET 200 distributed I/O

ET 200S

I/O modules SIPLUS power modules for PM-E electronic

Ordering data	Order No.	Accessories	Order No.
Power module PM-E SIPLUS (extended temperature range and medial exposure) PM-E 24 VDC power module ¹⁾ For electronic modules; with diagnostics	6AG1 138-4CA01-2AA0		See SIMATIC PM-E power modules, page 9/70
24 to 48 VDC PM-E power module For electronic modules; with diagnostics; with status bit "load voltage" present	6AG1 138-4CA50-2AB0		
Power module PM-E 24 to 48 VDC, 24 to 230 VAC For electronic modules; with diagnostics and fuse	6AG1 138-4CB11-2AB0		

¹⁾ Can be used for all electronic and technology modules except
2 DI 120 V AC / 2 DI 230 V AC / 2 DO 120/230 V AC

Selection tool for terminal modules

Power modules	Terminal modules TM-P for power modules			
Screw-type terminal type designation	TM-P15S23-A1	TM-P15S23-A0	TM-P15S22-01	TM-P30S44-A0
Order number 6ES7 193...	4CC20-0AA0	4CD20-0AA0	4CE00-0AA0	4CK20-0AA0
Spring-loaded terminal type designation	TM-P15C23-A1	TM-P15C23-A0	TM-P15C22-01	TM-P30C44-A0
Order number 6ES7 193...	4CC30-0AA0	4CD30-0AA0	4CE10-0AA0	4CK30-0AA0
FastConnect type designation	TM-P15N23-A1	TM-P15N23-A0	TM-P15N22-01	Soon to come
Order number 6ES7 193...	4CC70-0AA0	4CD70-0AA0	4CE60-0AA0	
PM-E 24 V DC	•	•	•	
PM-E 24 V DC to 48 V DC	•	•	•	
PM-E 24 V DC/120/230 V AC	•	•	•	
PM-E F 24 V DC PROFIsafe				•

Overview



- Applicable only on IM 151-1 Standard interface modules as of 6ES7151-1AA04-0AB0 and IM 151-1 High Feature as of 6ES7151-1BA02-0AB0
- Suitable for all TM-E terminal modules (15 mm and 30 mm construction width)
- Reserves one slot for any electronic module. The reserve module is inserted into the reserved slot of the ET 200S configuration.
- Terminal module can be wired up for the function to be used later
- The reserve module has no connection to the terminals of the TM-E terminal module. The TM-E terminal module can therefore be completely wired up and prepared for its future purpose.
- Parameterizable diagnostic response with IM 151-1 STANDARD and IM 151-1 HIGH FEATURE
- Facilitates retrofitting of I/O modules during operation
- Options can be released via the PLC program without the need for re-engineering

Technical specifications

	6ES7 138-4AA01-0AA0	6ES7 138-4AA11-0AA0
Power losses		
Power loss, typ.	0.025 W	0.025 W
Address area		
Occupied address area	according to configured module	according to configured module
• Inputs		
Digital inputs		
Number/binary inputs	0	0
Interrupts/diagnostics/ status information		
Diagnostic messages		
• Diagnostic functions	No	No
Diagnostics indication LED		
• Status indicator digital input (green)	No	No
Parameter		
Remark	according to configured module	according to configured module
Dimensions		
Width	15 mm	30 mm
Height	81 mm	81 mm
Depth	52 mm	52 mm
Weight		
Weight, approx.	33 g	55 g

Ordering data

Order No.

Reserve modules for ET 200S

- for reserving unused slots
- 15 mm overall width (5 units)
- 30 mm overall width (1 unit)

6ES7 138-4AA01-0AA0
6ES7 138-4AA11-0AA0

SIMATIC ET 200 distributed I/O

ET 200S

I/O modules

Potential isolation module

Overview

- Potential isolation module with 4 outputs
- Output current 5 A per output / 10 A per module
- Nominal load voltage: According to the load voltage on the power module of this load voltage group
- Is suitable for all terminal modules TM-E (construction width 15 mm)

Technical specifications

Potential isolation module	6ES7138-4FD00-0AA0
Module-specific specifications	
Supported synchronous operation	no
Number of outputs	4
Cable length	
• Unshielded	max. 600 m
• Shielded	max. 1000 m
Parameter length	1 byte
Voltages, Currents, Potentials	
Nominal load voltage L+ (from power module)	24 ... 48 V DC; 24 AC ... 230 V
• Polarity reversal protection	no
Total current of the outputs (per module)	max. 10 A
Potential isolation	
• Between the channels	no
• Between the channels and backplane bus	Yes
Permissible potential difference	
• Between the supply voltage and the backplane bus	75 V DC, 240 V AC
Isolation tested	
• Between the supply voltage and the backplane bus	500 V DC, 1500 V AC
Diagnostic alarm	no
Data for selecting an actuator	
Short-circuit protection for the output	No, possible via PM-E or external
Dimensions and weight	
Dimensions W × H × D (mm, the total dimensions depend on the selected terminal module)	15 × 81 × 52
Weight	Approx. 33 g

Ordering data

Order No.

Potential isolation module for ET 200S

6ES7138-4FD00-0AA0

for preparing the load voltage on additional terminals, 15 mm construction width, 1 piece

Accessories for labeling

Label sheets DIN A4 (10 pieces)

Each sheet contains 60 labeling strips for peripheral modules and 20 labeling strips for interface modules

- petrol
- red
- yellow
- light beige

6ES7 193-4BH00-0AA0

6ES7 193-4BD00-0AA0

6ES7 193-4BB00-0AA0

6ES7 193-4BA00-0AA0

Overview



- 2, 4 and 8-channel digital inputs and outputs for the ET 200S
- Can be plugged onto TM-E terminal modules with automatic coding.
- High-feature versions for enhanced plant availability, additional functions and comprehensive diagnostics
- Hot swapping of modules possible

Technical specifications

	6ES7 131-4BB01-0AA0	6ES7 131-4BB01-0AB0	6ES7 131-4BD01-0AA0	6ES7 131-4BD01-0AB0	6ES7 131-4BD51-0AA0	6ES7 131-4BF00-0AA0
Supply voltage						
24 V DC	Yes; From power module	Yes; From power module	Yes; From power module	Yes; From power module	Yes; From power module	Yes
permissible range, lower limit (DC)	20.4 V	20.4 V	20.4 V	20.4 V	20.4 V	20.4 V
permissible range, upper limit (DC)	28.8 V	28.8 V	28.8 V	28.8 V	28.8 V	28.8 V
Reverse polarity protection	Yes	Yes	Yes	Yes	Yes	Yes
Input current						
from backplane bus 3.3 V DC, max.	10 mA	10 mA	10 mA	10 mA		10 mA
from supply voltage L+, max.	Dependent on encoder	Dependent on encoder	Dependent on encoder	Dependent on encoder	Dependent on encoder	Dependent on encoder
Encoder supply						
Number of outputs						0; no encoder supply
Output voltage	min. L+ (-0.5 V), under load	min. L+ (-0.5 V), under load	min. L+ (-0.5 V), under load	min. L+ (-0.5 V), under load	max. M +0.5 V, under load	
Output current, rated value	500 mA	500 mA	500 mA	500 mA	500 mA	
Output current, permissible range	0 to 500 mA	0 to 500 mA	0 to 500 mA	0 to 500 mA	0 to 500 mA	
Output current						
• Short-circuit protection		Yes; Electronic		Yes; Electronic		
Power losses						
Power loss, typ.	0.4 W	0.4 W	0.7 W	0.7 W	0.7 W	1.2 W
Address area						
Address space per module						
• with packing	2 bit	2 bit	4 bit	4 bit	4 bit	
• without packing	1 byte	1 byte	1 byte	1 byte	1 byte	1 byte
Digital inputs						
Number/binary inputs	2	2	4	4	4	8
Input characteristic curve acc. to IEC 61131, Type 1	Yes	Yes	Yes	Yes	Yes	Yes; 2-wire sensors connectable
Number of simultaneously controllable inputs						8
Input voltage						
• Type of input voltage	DC	DC	DC	DC	DC	DC
• Rated value, DC	24 V	24 V	24 V	24 V	24 V	24 V
• for signal "0"	-30 to +5 V	-30 to +5 V	-30 to +5 V	-30 to +5 V	-5 to +30 V	-30 to +5 V
• for signal "1"	15 to 30 V	11 to 30 V	15 to 30 V	11 to 30 V	-15 to -30 V	15 to 30 V
Input current						
• for signal "1", typ.	7 mA; at 24 V	8 mA	7 mA; at 24 V	8 mA	7 mA; at 24 V	5 mA

SIMATIC ET 200 distributed I/O

ET 200S

I/O modules

Digital electronic modules

Technical specifications (continued)

	6ES7 131-4BB01-0AA0	6ES7 131-4BB01-0AB0	6ES7 131-4BD01-0AA0	6ES7 131-4BD01-0AB0	6ES7 131-4BD51-0AA0	6ES7 131-4BF00-0AA0
Input delay (for rated value of input voltage)						
• for standard inputs						
- Parameterizable	No	Yes; 0.1 / 0.5 / 3 / 15 ms	No	Yes; 0.1 / 0.5 / 3 / 15 ms	No	No
- at "0" to "1", min.	2 ms; typically 3 ms	0.05 / 0.4 / 2.7 / 14.85	2 ms; typically 3 ms	0.05 / 0.4 / 2.7 / 14.85	2 ms; typically 3 ms	2 ms
- at "0" to "1", max.	4.5 ms	0.15 / 0.6 / 3.3 / 15,15	4.5 ms	0.15 / 0.6 / 3.3 / 15,15	4.5 ms	4.5 ms
- at "1" to "0", min.	2 ms; typically 3 ms	0.05 / 0.4 / 2.7 / 14.85	2 ms; typically 3 ms	0.05 / 0.4 / 2.7 / 14.85	2 ms; typically 3 ms	2 ms
- at "1" to "0", max.	4.5 ms	0.15 / 0.6 / 3.3 / 15,15	4.5 ms	0.15 / 0.6 / 3.3 / 15,15	4.5 ms	4.5 ms
Cable length						
• Cable length, shielded, max.	1 000 m	1 000 m	1 000 m	1 000 m	1 000 m	1 000 m
• Cable length unshielded, max.	600 m	600 m	600 m	600 m	600 m	600 m
Encoder						
Connectable encoders						
• 2-wire sensor	Yes	Yes	Yes	Yes	Yes	Yes
- Permissible quiescent current (2-wire sensor), max.	1.5 mA	1.5 mA	1.5 mA	1.5 mA	1.5 mA	1.5 mA
Isochronous mode						
Isochronous operation (application synchronized up to terminal)						Yes; TWE = 3000 us
Interrupts/diagnostics/ status information						
Diagnostic messages						
• Diagnostic functions	No	Yes	No	Yes	No	No
• Short circuit		Yes; Short-circuit of outputs to ground; module by module		Yes; Short-circuit of outputs to ground; module by module		
Diagnostics indication LED						
• Group error SF (red)	No	Yes	No	Yes	No	Yes
• Status indicator digital input (green)	Yes; per channel	Yes; per channel	Yes; per channel	Yes; per channel	Yes; per channel	Yes
Parameter						
Remark						3-byte parameter (not accessible for the user)
Diagnosis: short circuit		Disable / enable		Disable / enable		
Galvanic isolation						
Galvanic isolation digital inputs						
• between the channels	No	No	No	No	No	No
• between the channels and the backplane bus	Yes	Yes	Yes	Yes	Yes	Yes
Permissible potential difference between different circuits	75 VDC / 60 VAC	75 VDC / 60 VAC	75 VDC / 60 VAC	75 VDC / 60 VAC	75 VDC / 60 VAC	75 VDC / 60 VAC
Isolation						
Isolation checked with	500 V DC	500 V DC	500 V DC	500 V DC	500 V DC	500 V DC
Dimensions						
Width	15 mm	15 mm	15 mm	15 mm	15 mm	15 mm
Height	81 mm	81 mm	81 mm	81 mm	81 mm	81 mm
Depth	52 mm	52 mm	52 mm	52 mm	52 mm	52 mm
Weight						
Weight, approx.	35 g	35 g	35 g	35 g	35 g	35 g

Technical specifications (continued)

	6ES7 131-4CD02-0AB0	6ES7 131-4EB00-0AB0	6ES7 131-4FB00-0AB0	6ES7 131-4RD02-0AB0	6ES7 131-4BF50-0AA0
Supply voltage					
24 V DC	Yes; From power module			Yes	Yes; From power module
permissible range, lower limit (DC)	24 V			20.4 V	20.4 V
permissible range, upper limit (DC)	48 V			28.8 V	28.8 V
24 V AC	Yes				
120 V AC		Yes; From power module			
230 V AC			Yes		
permissible range, lower limit (AC)	24 V				
permissible range, upper limit (AC)	48 V				
Reverse polarity protection	Yes; AC or DC automatic				Yes
Input current					
from backplane bus 3.3 V DC, max.	10 mA	6 mA	6 mA		
from supply voltage L+, max.	Dependent on encoder			Dependent on encoder	Dependent on encoder
from supply voltage L1, max.		Dependent on encoder	Dependent on encoder		
Encoder supply					
Number of outputs				1	
Output voltage	min. L+ (-0.5 V), under load			min. 8.2 V, loaded	
Output current, rated value	500 mA			45 mA	
Output current, permissible range	0 to 500 mA				
Output current • Short-circuit protection	Yes; per module			Yes; Electronic	
Power losses					
Power loss, typ.	0.7 W	0.5 W	0.7 W	1.6 W	1.2 W
Address area					
Address space per module • with packing • without packing	4 bit 1 byte	2 bit 1 byte	2 bit 1 byte	4 bit 1 byte	
Digital inputs					
Number/binary inputs	4	2	2	4	8
Number of NAMUR inputs				4	
Parallel switching of inputs				No	
Input characteristic curve acc. to IEC 61131, Type 1	Yes	Yes	Yes		Yes
Number of simultaneously controllable inputs				4	
Input voltage • Type of input voltage • Rated value, AC • Rated value, DC • Rated value, UC • for signal "0" • for signal "1" • Frequency range	AC/DC 24 V; 24 to 48 V UC -6 to 6 V DC, 0 to 5 V AC -15 to -57.6 V DC; -15 to 57.6 V DC; 15 to 48 V AC 47 to 63 Hz	AC 120 V 0 to 20 V AC 79 to 132 V AC 47 to 63 Hz	AC 230 V 0 to 40 V AC 164 to 264 V AC 47 to 63 Hz	DC 4	DC 24 V 30 to -5 V -15 to -30 V

SIMATIC ET 200 distributed I/O

ET 200S

I/O modules

Digital electronic modules

Technical specifications (continued)

	6ES7 131-4CD02-0AB0	6ES7 131-4EB00-0AB0	6ES7 131-4FB00-0AB0	6ES7 131-4RD02-0AB0	6ES7 131-4BF50-0AA0
Input current <ul style="list-style-type: none"> for signal "1", typ. for 10 k switched contact <ul style="list-style-type: none"> for signal "0" for signal "1" for unswitched contact <ul style="list-style-type: none"> for signal "0", max. (permissible quiescent current) for signal "1" for NAMUR encoders <ul style="list-style-type: none"> for signal "0" for signal "1" 	10 mA; 4 to 10 mA	3 mA; 3 to 9 mA	5 mA; 5 to 15 mA	0.35 to 1.2 mA 2.1 to 7 mA 0.5 mA typ. 8 mA 0.35 mA to 1.2 mA 2.1 to 7 mA	6 mA; at 24 V
Input delay (for rated value of input voltage) <ul style="list-style-type: none"> for standard inputs <ul style="list-style-type: none"> Parameterizable <ul style="list-style-type: none"> at "0" to "1", min. at "0" to "1", max. at "1" to "0", min. at "1" to "0", max. 	15 ms 15 ms	15 ms 25 ms	15 ms 45 ms	4.6 µs 4.6 µs	No 2 ms 4.5 ms 2 ms 4.5 ms
Encoder connection <ul style="list-style-type: none"> Fixed current limitation for wire break monitoring, min. 	18 kΩ; Rated voltage 24 V (15 V to 35 V); rated voltage 48 V (30 V to 60 V); 39 kohms				
Cable length <ul style="list-style-type: none"> Cable length, shielded, max. Cable length unshielded, max. 	1 000 m 600 m	1 000 m 600 m	1 000 m 600 m	200 m	1 000 m 600 m
Encoder Connectable encoders <ul style="list-style-type: none"> 2-wire sensor <ul style="list-style-type: none"> Permissible quiescent current (2-wire sensor), max. 	Yes 2 mA; (0.5 to 2 mA), a minimum load current is necessary for wire break diagnostics.	No 1 mA	No 2 mA		Yes 1.5 mA
Isochronous mode Isochronous operation (application synchronized up to terminal)	Yes	No	No		Yes
Interrupts/diagnostics/status information Alarms <ul style="list-style-type: none"> Diagnostic alarm Hardware interrupt 				Yes; adjustable No	
Diagnostic messages <ul style="list-style-type: none"> Diagnostic functions Diagnostic information readable Short circuit 	Yes; Parameterizable	No No	No No	Yes; Diagnostic alarm Yes	No
Diagnostics indication LED <ul style="list-style-type: none"> Group error SF (red) Status indicator digital input (green) 	Yes Yes; per channel	Yes; per channel	Yes; per channel	Yes Yes; per channel	No Yes; per channel
Galvanic isolation Galvanic isolation digital inputs <ul style="list-style-type: none"> between the channels between the channels and the backplane bus between the channels and the load voltage L+ 	No Yes	No Yes	No Yes	No Yes Yes	No Yes

Technical specifications (continued)

	6ES7 131-4CD02-0AB0	6ES7 131-4EB00-0AB0	6ES7 131-4FB00-0AB0	6ES7 131-4RD02-0AB0	6ES7 131-4BF50-0AA0
Permissible potential difference between different circuits	75 VDC / 60 VAC			75 VDC / 60 VAC	75 VDC / 60 VAC
between M internally and the inputs		1500 V AC	1500 V AC		
Isolation Isolation checked with	2500 V DC	2500 V DC	4000 VDC	500 V DC	500 V DC
Dimensions Width	15 mm	15 mm	15 mm	15 mm	15 mm
Height	81 mm	81 mm	81 mm	81 mm	81 mm
Depth	52 mm	52 mm	52 mm	52 mm	52 mm
Weight Weight, approx.	35 g	31 g	31 g	35 g	35 g

	6ES7 132-4BB01-0AB0	6ES7 132-4BB01-0AA0	6ES7 132-4BB31-0AB0	6ES7 132-4BB31-0AA0	6ES7 132-4BD00-0AB0	6ES7 132-4BD02-0AA0
Supply voltage Reverse voltage protection	Yes; when using the same load voltage as on the power module	Yes; when using the same load voltage as on the power module	Yes; when using the same load voltage as on the power module	Yes; when using the same load voltage as on the power module	Yes; when using the same load voltage as on the power module	Yes; when using the same load voltage as on the power module
Load voltage L+ • Rated value (DC) • Reverse polarity protection	24 V; From power module Yes; polarity reversal can lead to the digital outputs being connected through	24 V; From power module Yes; polarity reversal can lead to the digital outputs being connected through	24 V; From power module Yes; polarity reversal can lead to the digital outputs being connected through	24 V; From power module Yes; polarity reversal can lead to the digital outputs being connected through	24 V; From power module Yes; polarity reversal can lead to the digital outputs being connected through	24 V; from PM Yes; polarity reversal can lead to the digital outputs being connected through
Input current from load voltage L+ (without load), max. from backplane bus 3.3 V DC, max.	5 mA; Per channel 10 mA	5 mA; Per module 10 mA	5 mA; Per channel 10 mA	5 mA; Per channel 10 mA	5 mA; Per channel 10 mA	10 mA; Per channel 10 mA
Power losses Power loss, typ.	0.4 W	0.4 W	1.4 W	1.4 W		0.8 W
Address area Address space per module • with packing • without packing	2 bit 1 byte	2 bit 1 byte	2 bit 1 byte	2 bit 1 byte	4 bit 1 byte	4 bit 1 byte
Digital inputs Cable length • Cable length, shielded, max. • Cable length unshielded, max.					1 000 m 600 m	
Digital outputs Number/binary outputs	2	2	2	2	4	4
Functionality/short-circuit strength • Response threshold, typ.	Yes; Per channel 1.5 A	Yes; Per channel 0.7 to 1.8 A	Yes; Per channel 4 A	Yes; Per channel 2.8 to 7.2 A	Yes; Per channel 0.7 to 1.5 A	Yes; per channel 1 to 1.5 A
Limitation of inductive shutdown voltage to	-55 to -60 V, typ. L+()	-55 to -60 V, typ. L+()	-55 to -60 V, typ. L+()	-55 to -60 V, typ. L+()	-55 to -60 V, L+()	(L+) -55 to -60 V
Lamp load, max.	2.5 W	5 W	5 W	10 W	5 W	5 W
Controlling a digital input	Yes	Yes	Yes	Yes	Yes	Yes
Load resistance range • lower limit • upper limit	48 Ω 3 400 Ω	48 Ω 3 400 Ω	12 Ω 3 400 Ω	12 Ω 3 400 Ω	48 Ω 3 400 Ω	48 Ω 3 400 Ω
Output voltage • for signal "1", min.	L+ (-1 V)	L+ (-1 V)	L+ (-1 V)	L+ (-1 V)	L+ (-1 V)	L+ (-1 V)

SIMATIC ET 200 distributed I/O

ET 200S

I/O modules

Digital electronic modules

Technical specifications (continued)

	6ES7 132-4BB01-0AB0	6ES7 132-4BB01-0AA0	6ES7 132-4BB31-0AB0	6ES7 132-4BB31-0AA0	6ES7 132-4BD00-0AB0	6ES7 132-4BD02-0AA0
Output current						
• for signal "1" rated value	0.5 A	0.5 A	2 A	2 A	0.5 A	0.5 A
• for signal "1" permissible range for 0 to 60 °C, min.	7 mA	7 mA	7 mA	7 mA	7 mA	7 mA
• for signal "1" permissible range for 0 to 60 °C, max.	600 mA	600 mA	2.4 A	2.4 A	600 mA	600 mA
• for signal "0" residual current, max.	0.3 mA	0.3 mA	0.5 mA	0.5 mA	0.3 mA	0.3 mA
Output delay with resistive load						
• "0" to "1", max.	100 µs	200 µs	100 µs	200 µs	100 µs	45 µs; Typical value
• "1" to "0", max.	400 µs	1.3 ms	400 µs	1.3 ms	300 µs	90 µs; Typical value
Parallel switching of 2 outputs						
• for increased power	No	No	No	No	No	No
• for redundant control of a load	Yes; per module	Yes; per module	Yes; per module	Yes; per module	Yes; per module	Yes; per module
Switching frequency						
• with resistive load, max.	100 Hz	100 Hz	100 Hz	100 Hz	100 Hz	800 Hz
• with inductive load, max.	2 Hz	2 Hz	2 Hz; 0.5 H	2 Hz; 0.5 H	2 Hz	2 Hz
• on lamp load, max.	10 Hz	10 Hz	10 Hz	10 Hz	10 Hz	10 Hz
Aggregate current of outputs (per group)						
• all mounting positions - up to 60 °C, max.	1 A	1 A	4 A	4 A	2 A	2 A
Cable length						
• Cable length, shielded, max.	1 000 m	1 000 m	1 000 m	1 000 m	1 000 m	1 000 m
• Cable length unshielded, max.	600 m	600 m	600 m	600 m	600 m	600 m
Isochronous mode						
Isochronous operation (application synchronized up to terminal)	Yes	No	Yes	No	Yes	Yes
Interrupts/diagnostics/status information						
Substitute values connectable	Yes; 0/1		Yes; 0/1			
Diagnostic messages						
• Diagnostic functions	Yes; Can be read out	No	Yes; Can be read out	No	Yes	No
• Wire break	Yes; channel by channel		Yes; channel by channel		Yes; Module-wise	
• Short circuit	Yes; channel by channel		Yes; channel by channel			
Diagnostics indication LED						
• Group error SF (red)	Yes		Yes		Yes; SF-LED (red)	
• Status indicator digital output (green)	Yes	Yes	Yes	Yes	Yes; Per channel	Yes
Parameter						
Remark	3 bytes	1 byte	3 bytes	1 byte		1 byte
Diagnosis: wire break	Disable / enable		Disable / enable			
Diagnosis: short circuit	Disable / enable		Disable / enable			
Behavior on CPU/Master STOP, channel-wise	Substitute a value/keep last value		Substitute a value/keep last value			
Galvanic isolation						
Galvanic isolation digital outputs						
• between the channels	No	No	No	No	No	No
• between the channels and the backplane bus	Yes	Yes	Yes	Yes	Yes	Yes
Isolation						
Isolation checked with	500 V DC	500 V DC	500 V DC	500 V DC	500 V DC	500 V DC
Dimensions						
Width	15 mm	15 mm	15 mm	15 mm	15 mm	15 mm
Height	81 mm	81 mm	81 mm	81 mm	81 mm	81 mm
Depth	52 mm	52 mm	52 mm	52 mm	52 mm	52 mm
Weight						
Weight, approx.	40 g	40 g	40 g	40 g	40 g	40 g

Technical specifications (continued)

	6ES7 132-4BF00-0AB0	6ES7 132-4BF00-0AA0
Supply voltage		
Reverse voltage protection	Yes; when using the same load voltage as on the power module	Yes
Load voltage L+		
• Rated value (DC)	24 V; From power module	24 V
• Reverse polarity protection	Yes; polarity reversal can lead to the digital outputs being connected through	Yes
Input current		
from load voltage L+ (without load), max.	5 mA; Per channel	5 mA; Per channel
from backplane bus 3.3 V DC, max.	10 mA	10 mA
Power losses		
Power loss, typ.		1.5 W
Address area		
Address space per module		
• with packing	Not relevant	
• without packing	1 byte	1 byte
Digital inputs		
Cable length		
• Cable length, shielded, max.	1 000 m	1 000 m
• Cable length unshielded, max.	600 m	600 m
Digital outputs		
Number/binary outputs	8	8
Functionality/short-circuit strength	Yes; Per channel	Yes; Per channel
• Response threshold, typ.	0.7 to 1.9 A	o.k.
Limitation of inductive shutdown voltage to	L+ -(47 to 60 V)	o.k.
Lamp load, max.	5 W	5 W
Controlling a digital input	Yes	Yes
Load resistance range		
• lower limit	48 Ω	48 Ω
• upper limit	3 400 Ω	3 400 Ω
Output voltage		
• for signal "1", min.	L+ (-1.0 V)	o.k.
Output current		
• for signal "1" rated value	0.5 A	0.5 A
• for signal "1" permissible range for 0 to 60 °C, min.	7 mA	7 mA
• for signal "1" permissible range for 0 to 60 °C, max.	600 mA	600 mA
• for signal "0" residual current, max.	0.3 mA	0.3 mA
Output delay with resistive load		
• "0" to "1", max.	300 μs	300 μs
• "1" to "0", max.	600 μs	600 μs
Parallel switching of 2 outputs		
• for increased power	No	No
• for redundant control of a load	Yes; per module	Yes
Switching frequency		
• with resistive load, max.	100 Hz	100 Hz
• with inductive load, max.	2 Hz	2 Hz
• on lamp load, max.	10 Hz	10 Hz
Aggregate current of outputs (per group)		
• all mounting positions - up to 60 °C, max.		4 A
• horizontal installation - up to 60 °C, max.	4 A	
• vertical installation - up to 40 °C, max.	4 A; At 55 °C and 24 V DC	
Cable length		
• Cable length, shielded, max.	1 000 m	1 000 m
• Cable length unshielded, max.	600 m	600 m

SIMATIC ET 200 distributed I/O

ET 200S

I/O modules

Digital electronic modules

Technical specifications (continued)

	6ES7 132-4BF00-0AB0	6ES7 132-4BF00-0AA0
Isochronous mode		
Isochronous operation (application synchronized up to terminal)	Yes	Yes; jitter incumbered < 100us
Interrupts/diagnostics/status information		
Diagnostic messages		
• Diagnostic functions	Yes	No
• Short circuit	Yes; Module-wise	
Diagnostics indication LED		
• Group error SF (red)	Yes; SF-LED (red)	
• Status indicator digital output (green)	Yes; Per channel	Yes
Parameter		
Remark	1 byte	3-byte parameter (not accessible for the user)
Galvanic isolation		
Galvanic isolation digital outputs		
• between the channels	No	No
• between the channels and the backplane bus	Yes	Yes
Isolation		
Isolation checked with	500 V DC	500 V DC
Dimensions		
Width	15 mm	15 mm
Height	81 mm	81 mm
Depth	52 mm	52 mm
Weight		
Weight, approx.	40 g	40 g

	6ES7 132-4BD30-0AB0	6ES7 132-4BD32-0AA0	6ES7 132-4FB01-0AB0	6ES7 132-4HB01-0AB0	6ES7 132-4HB12-0AB0
Supply voltage					
Reverse voltage protection	Yes; when using the same load voltage as on the power module	Yes; When using the same load voltage as	Yes; when using the same load voltage as on the power module		
Load voltage L+					
• Rated value (DC)	24 V; From power module	24 V; From power module	24 V; From power module	24 V; From power module	24 V; From power module
• Reverse polarity protection	Yes; polarity reversal can lead to the digital outputs being connected through	Yes	Yes	Yes	Yes
Input current					
from load voltage L+ (without load), max.	5 mA; Per channel	10 mA; Per channel	30 mA	30 mA	30 mA
from backplane bus 3.3 V DC, max.	10 mA	10 mA	18 mA	10 mA	10 mA
Power losses					
Power loss, typ.	1.6 W	1.6 W	4 W	0.6 W	0.6 W
Address area					
Address space per module					
• with packing	4 bit	4 bit	2 bit	2 bit	2 bit
• without packing	1 byte	1 byte	1 byte	1 byte	1 byte
Digital inputs					
Cable length					
• Cable length, shielded, max.	1 000 m				
• Cable length unshielded, max.	600 m				

Technical specifications (continued)

	6ES7 132-4BD30-0AB0	6ES7 132-4BD32-0AA0	6ES7 132-4FB01-0AB0	6ES7 132-4HB01-0AB0	6ES7 132-4HB12-0AB0
Digital outputs					
Number/binary outputs	4	4	2	2	2
Functionality/short-circuit strength	Yes; Per channel	Yes; Per channel	Yes; via fuse in power module	No	No
• Response threshold, typ.	5 to 10 A	2.8 to 7.2 A			
Limitation of inductive shutdown voltage to	L+ (-37 to 41V)	Typ. L+ (-55 to -60 V)	-55 to -60 V	No	No
Lamp load, max.		10 W	100 W		
Controlling a digital input	Yes	Yes	Yes; possible	Yes	Yes
Load resistance range					
• lower limit	12 Ω	12 Ω			
• upper limit	3 400 Ω	3 400 Ω			
Output voltage					
• for signal "1", min.	L+ (-1.0 V)	L+ (-1.0 V)	L+ (-1.5 V)		
Output current					
• for signal "1" rated value	2 A	2 A	2 A	5 A	5 A
• for signal "1" permissible range for 0 to 60 °C, min.	7 mA	7 mA	0.1 mA		
• for signal "1" permissible range for 0 to 60 °C, max.	2.4 A	2.4 A	2.2 A		
• for signal "1" minimum load current				8 mA	8 mA
• for signal "0" residual current, max.	0.5 mA	0.5 mA	3 mA		
Output delay with resistive load					
• "0" to "1", max.	250 μs	50 μs; Typ. 45 μs	15 ms		
• "1" to "0", max.	400 μs	120 μs; Typ. 90 μs	15 ms		
Parallel switching of 2 outputs					
• for increased power	No	No	No		
• for redundant control of a load	Yes; per module	Yes; per module	Yes; per module		
Switching frequency					
• with resistive load, max.	100 Hz	1 000 Hz	10 Hz	2 Hz	2 Hz
• with inductive load, max.	2 Hz	2 Hz; At 0.5 H	0.5 Hz	0.5 Hz	0.5 Hz
• on lamp load, max.	10 Hz	10 Hz	1 Hz	2 Hz	2 Hz
Aggregate current of outputs (per group)					
• all mounting positions					
- up to 40 °C, max.			2 A		
- up to 50 °C, max.			1.5 A		
- up to 60 °C, max.		4 A	1 A		
• horizontal installation					
- up to 60 °C, max.	4 A				
• vertical installation					
- up to 40 °C, max.	4 A; At 55 °C and 24 V DC	4 A; At 55 °C and 24 V DC			
Relay outputs					
• Switching capacity of contacts					
- Thermal continuous current, max.				5 A	5 A
Cable length					
• Cable length, shielded, max.	1 000 m	1 000 m	1 000 m	1 000 m	1 000 m
• Cable length unshielded, max.	600 m	600 m	600 m	600 m	600 m
Isochronous mode					
Isochronous operation (application synchronized up to terminal)	Yes	Yes		No	No

SIMATIC ET 200 distributed I/O

ET 200S

I/O modules

Digital electronic modules

Technical specifications (continued)

	6ES7 132-4BD30-0AB0	6ES7 132-4BD32-0AA0	6ES7 132-4FB01-0AB0	6ES7 132-4HB01-0AB0	6ES7 132-4HB12-0AB0
Interrupts/diagnostics/status information					
Substitute values connectable				Yes; 0/1	Yes; 0/1
Diagnostic messages					
• Diagnostic functions	Yes	No	No	No	No
• Short circuit	Yes; Module-wise				
Diagnosics indication LED					
• Group error SF (red)	Yes; SF-LED (red)				
• Status indicator digital output (green)	Yes; Per channel	Yes	Yes	Yes	Yes
Parameter					
Remark		1 byte	3 bytes		
Behavior on CPU/Master STOP, channel-wise			Substitute a value/keep last value, 0/1	Substitute a value/keep last value	Substitute a value/keep last value
Galvanic isolation					
Galvanic isolation digital outputs					
• between the channels	No	No	No	Yes	Yes
• between the channels and the backplane bus	Yes	Yes	Yes	Yes	Yes
• between the channels and the load voltage L+				Yes	Yes
Isolation					
Isolation checked with	500 V DC	500 V DC	2500 V DC		
tested with					
• Channels against backplane bus and load voltage L+				1500 V AC	1500 V AC
• Load voltage L+ against backplane bus				500 V DC	500 V DC
Ambient conditions					
Extended ambient conditions					
• Relative to ambient temperature-atmospheric pressure-installation				Tmin ... Tmax at 1080 hPa ... 795 hPa (-1000 m ... +2000 m) // Tmin ... (Tmax - 10K) at 795 hPa ... 658 hPa (+2000 m ... +3500 m) // Tmin ... (Tmax - 20K) at 658 hPa ... 540 hPa (+3500 m ... +5000 m)	Tmin ... Tmax at 1080 hPa ... 795 hPa (-1000 m ... +2000 m) // Tmin ... (Tmax - 10K) at 795 hPa ... 658 hPa (+2000 m ... +3500 m) // Tmin ... (Tmax - 20K) at 658 hPa ... 540 hPa (+3500 m ... +5000 m)
• altitude					
• Relative humidity				100 %; Relative humidity, incl. condensation / frost permitted (no commissioning under condensation conditions)	100 %; Relative humidity, incl. condensation / frost permitted (no commissioning under condensation conditions)
- with condensation					
Dimensions					
Width	15 mm	15 mm	15 mm	15 mm	15 mm
Height	81 mm	81 mm	81 mm	81 mm	81 mm
Depth	52 mm	52 mm	52 mm	52 mm	52 mm
Weight					
Weight, approx.	40 g	40 g	37 g	50 g	50 g

Technical specifications (continued)

	6ES7 132-4BF50-0AA0	6ES7 132-4BD50-0AA0	6ES7 132-4HB50-0AB0
Supply voltage			
Reverse voltage protection	Yes; when using the same correctly polarized load voltage as on the power module	Yes; When using the same load voltage as	
Load voltage L+			
• Rated value (DC)	24 V; From power module	24 V; From power module	24 V; From power module
• Reverse polarity protection	Yes	Yes	Yes
Input current			
from load voltage L+ (without load), max.	5 mA	5 mA; Per channel	30 mA
from backplane bus 3.3 V DC, max.	10 mA	10 mA	10 mA
Power losses			
Power loss, typ.	1.5 W	0.8 W	0.6 W
Address area			
Address space per module			
• with packing		4 bit	2 bit
• without packing	1 byte	1 byte	1 byte
Digital inputs			
Cable length			
• Cable length, shielded, max.		1 000 m	
• Cable length unshielded, max.		600 m	
Digital outputs			
Number/binary outputs	8	4	2
Functionality/short-circuit strength	Yes; Per channel	Yes; Per channel	No
• Response threshold, typ.	1.5 A		
Limitation of inductive shutdown voltage to	Typ. 47 V		No
Lamp load, max.	5 W	5 W	
Controlling a digital input	Yes	Yes	Yes
Load resistance range			
• lower limit	48 Ω	48 Ω	
• upper limit	3 400 Ω	3 400 Ω	
Output voltage			
• for signal "1", min.	Max. 1 V	1 V	
Output current			
• for signal "1" rated value	0.5 A	0.5 A	5 A
• for signal "1" permissible range for 0 to 60 °C, min.	5 mA	5 mA	
• for signal "1" permissible range for 0 to 60 °C, max.	700 mA	700 mA	
• for signal "1" minimum load current			8 mA
• for signal "0" residual current, max.	5 μA	5 μA	
Output delay with resistive load			
• "0" to "1", max.	300 μs	300 μs	
• "1" to "0", max.	600 μs	600 μs	
Parallel switching of 2 outputs			
• for increased power	No	No	
• for redundant control of a load	Yes; per module	Yes; per module	
Switching frequency			
• with resistive load, max.	100 Hz	100 Hz	2 Hz
• with inductive load, max.	0.5 Hz	0.5 Hz	0.5 Hz
• on lamp load, max.	10 Hz	10 Hz	2 Hz
Aggregate current of outputs (per group)			
• all mounting positions - up to 60 °C, max.	4 A	2 A	
Relay outputs			
• Switching capacity of contacts - Thermal continuous current, max.			5 A
Cable length			
• Cable length, shielded, max.	1 000 m		1 000 m
• Cable length unshielded, max.	600 m		600 m

SIMATIC ET 200 distributed I/O

ET 200S

I/O modules

Digital electronic modules

Technical specifications (continued)

	6ES7 132-4BF50-0AA0	6ES7 132-4BD50-0AA0	6ES7 132-4HB50-0AB0
Isochronous mode			
Isochronous operation (application synchronized up to terminal)	Yes	Yes	No
Interrupts/diagnostics/status information			
Substitute values connectable			Yes; 0/1
Diagnostic messages			
• Diagnostic functions	No	No	No
Diagnostics indication LED			
• Status indicator digital output (green)	Yes	Yes	Yes
Parameter			
Remark	3 bytes	1 byte	
Behavior on CPU/Master STOP, channel-wise			Substitute a value/keep last value
Galvanic isolation			
Galvanic isolation digital outputs			
• between the channels	No	No	Yes
• between the channels and the backplane bus	Yes	Yes	Yes
• between the channels and the load voltage L+			Yes
Isolation			
Isolation checked with	500 V DC	500 V DC	
tested with			
• Channels against backplane bus and load voltage L+			1500 V AC
• Load voltage L+ against backplane bus			500 V DC
Ambient conditions			
Extended ambient conditions			
• Relative to ambient temperature-atmospheric pressure-installation altitude			Tmin ... Tmax at 1080 hPa ... 795 hPa (-1000 m ... +2000 m) // Tmin ... (Tmax - 10K) at 795 hPa ... 658 hPa (+2000 m ... +3500 m) // Tmin ... (Tmax - 20K) at 658 hPa ... 540 hPa (+3500 m ... +5000 m)
• Relative humidity - with condensation			100 %; Relative humidity, incl. condensation / frost permitted (no commissioning under condensation conditions)
Dimensions			
Width	15 mm	15 mm	15 mm
Height	81 mm	81 mm	81 mm
Depth	52 mm	52 mm	52 mm
Weight			
Weight, approx.	40 g	40 g	50 g

Ordering data	Order No.	Order No.
Digital input modules		
Ordering unit 5 items		
• 2 DI 24 V DC Standard	6ES7 131-4BB01-0AA0	
• 2 DI 24 V DC High Feature	6ES7 131-4BB01-0AB0	
• 4 DI 24 V DC Standard	6ES7 131-4BD01-0AA0	
• 4 DI 24 V DC High Feature	6ES7 131-4BD01-0AB0	
• 2 DI 120 V AC	6ES7 131-4EB00-0AB0	
• 2 DI 230 V AC	6ES7 131-4FB00-0AB0	
• 4 DI 24 to 48 V UC	6ES7 131-4CD02-0AB0	
• 4 DI 24 V DC SOURCE INPUT	6ES7 131-4BD51-0AA0	
Ordering unit 1 item		
• 4 DI 24 V DC NAMUR	6ES7 131-4RD02-0AB0	
• 8 DI 24 V DC Standard	6ES7 131-4BF00-0AA0	
• 8 DI, 24 VDC, standard SOURCE INPUT	6ES7 131-4BF50-0AA0	
Digital output modules		
Ordering unit 5 items		
• 2 DO 24 V DC/0.5 A Standard	6ES7 132-4BB01-0AA0	
• 2 DO 24 V DC/0.5 A High Feature	6ES7 132-4BB01-0AB0	
• 2 DO 24 V DC/2 A Standard	6ES7 132-4BB31-0AA0	
• 2 DO 24 V DC/2 A High Feature	6ES7 132-4BB31-0AB0	
• 4 DO 24 V DC/0.5 A Standard	6ES7 132-4BD02-0AA0	
• 4 DO, 24 VDC / 0.5 A, standard SOURCE OUTPUT	6ES7 132-4BD50-0AA0	
• 4 DO 24 V DC/0.5 A High Feature	6ES7 132-4BD00-0AB0	
• 8 DO 24 V DC/0.5 A High Feature	6ES7 132-4BF00-0AB0	
• 4 DO 24 V DC/2 A Standard	6ES7 132-4BD32-0AA0	
• 4 DO 24 V DC/2 A High Feature	6ES7 132-4BD30-0AB0	
• 2 DO 24 to 230 V AC/2 A	6ES7 132-4FB01-0AB0	
• 2 DO 24 V DC to 230 V AC/5 A relay, NO contact	6ES7 132-4HB01-0AB0	
• 2 DO 24...48 V DC/5 A, 24...230 V AC/5 A relay, changeover contact	6ES7 132-4HB12-0AB0	
Ordering unit 1 item		
• 2 DO 24...48 V DC/5 A, 24...230 V AC/5 A relay, changeover contact, with manual operation	6ES7 132-4HB50-0AB0	
• 8 DO 24 V DC/0.5 A Standard	6ES7 132-4BF00-0AA0	
• 8 DO, 24 V DC/0.5 A, standard sink output	6ES7 132-4BF50-0AA0	
Ordering unit 100 items		
• 8 DO DC 24 V/0.5 A Standard	6ES7 132-4BF00-4AA0	
Accessories		
Label sheets DIN A4 (10 pieces)		
Each sheet contains 60 labeling strips for peripheral modules and 20 labeling strips for interface modules		
• petrol		6ES7 193-4BH00-0AA0
• red		6ES7 193-4BD00-0AA0
• yellow		6ES7 193-4BB00-0AA0
• light beige		6ES7 193-4BA00-0AA0

SIMATIC ET 200 distributed I/O

ET 200S

I/O modules
SIPLUS digital electronic modules

Overview



- 2, 4 and 8-channel digital inputs and outputs for the ET 200S
- Can be plugged onto TM-E terminal modules with automatic coding
- High-feature versions for enhanced plant availability, additional functions and comprehensive diagnostics
- Hot swapping of modules possible

Note:

SIPLUS extreme products are based on Siemens Industry standard products. The contents listed here were taken from the respective standard products. SIPLUS extreme-specific information was added.

	SIPLUS digital input module 4 DI 24 V DC Standard	SIPLUS digital input module 4 DI 24 V DC High Feature	SIPLUS digital input module 8 DI 24 V DC Standard
Order number	6AG1 131-4BD01-2AA0	6AG1 131-4BD01-7AB0	6AG1 131-4BF00-7AA0
Order number based on	6ES7 131-4BD01-0AA0	6ES7 131-4BD01-0AB0	6ES7 131-4BF00-0AA0
Ambient temperature range	-25 ... +60 °C	-25 ... +70 °C	
Conformal coating	Coating of the printed circuit boards and the electronic components		
Technical data	The technical data of the standard product applies except for the ambient conditions.		

	SIPLUS digital input module 8 DI SOURCE INPUT 24 V DC	SIPLUS digital output module 2 DO 24 V DC/0.5 A High Feature	SIPLUS digital output module 2 DO 24 V DC/2 A High Feature
Order number	6AG1 131-4BF50-7AA0	6AG1 132-4BB01-2AB0	6AG1 132-4BB31-7AB0
Order number based on	6ES7 131-4BF50-0AA0	6ES7 132-4BB01-0AB0	6ES7 132-4BB31-0AB0
Ambient temperature range	-40 ... +70 °C	-25 ... +60 °C	-25 ... +70 °C
Conformal coating	Coating of the printed circuit boards and the electronic components		
Technical data	The technical data of the standard product applies except for the ambient conditions.		

	SIPLUS digital output module 4 DO 24 V DC/0.5 A Standard	SIPLUS digital output module 4 DO 24 V DC/2 A Standard	SIPLUS digital output module 8 DO 24 V DC/0.5 A Standard
Order number	6AG1 132-4BD02-7AA0	6AG1 132-4BD32-2AA0	6AG1 132-4BF00-7AA0
Order number based on	6ES7 132-4BD02-0AA0	6ES7 132-4BD32-0AA0	6ES7 132-4BF00-0AA0
Ambient temperature range	-25 ... +70 °C	-25 ... +60 °C	-25 ... +70 °C
Conformal coating	Coating of the printed circuit boards and the electronic components		
Technical data	The technical data of the standard product applies except for the ambient conditions.		

	SIPLUS digital output module 8 DO 24 V DC/0.5 A Standard SOURCE OUTPUT	SIPLUS digital output module 2 DO 24 V DC to 230 V AC/5 A relay, NO contact	SIPLUS digital output module 2 DO 24...48 V DC/5 A, 24...230 V AC/5 A relay, changeover contact
Order number	6AG1 132-4BF50-7AA0	6AG1 132-4HB01-2AB0	6AG1 132-4HB12-2AB0
Order number based on	6ES7 132-4BF50-0AA0	6ES7 132-4HB01-0AB0	6ES7 132-4HB12-0AB0
Ambient temperature range	-25 ... +70 °C	-25 ... +70 °C	-25 ... +60 °C
Conformal coating	Coating of the printed circuit boards and the electronic components		
Technical data	The technical data of the standard product applies except for the ambient conditions.		

Overview (continued)		Ordering data	Order No.
Ambient conditions		SIPLUS digital input modules	
Relative humidity	100%, condensation/frost permissible. No commissioning if condensation present.	(extended temperature range and medial exposure)	
Biologically active substances, compliance with EN 60721-3-3	Class 3B2 mold and fungal spores (excluding fauna). The supplied plug covers must remain in place over the unused interfaces during operation!	Ordering unit 5 units	
Chemically active substances, compliance with EN 60721-3-3	Class 3C4 incl. salt spray in accordance with EN60068-2-52 (degree of severity 3). The supplied plug covers must remain in place over the unused interfaces during operation!	<ul style="list-style-type: none"> • 4 DI 24 V DC Standard • 4 DI 24 V DC High Feature • 8 DI 24 V DC Standard 	6AG1 131-4BD01-2AA0 6AG1 131-4BD01-7AB0 6AG1 131-4BF00-7AA0
Mechanically active substances, compliance with EN 60721-3-3	Class 3S4 incl. sand, dust. The supplied plug covers must remain in place over the unused interfaces during operation!	Ordering unit 1 unit	
Air pressure (depending on the highest positive temperature range specified)	1080 ... 795 hPa (-1000 ... +2000 m) see ambient temperature range 795 ... 658 hPa (+2000 ... +3500 m) derating 10 K 658 ... 540 hPa (+3500 ... +5000 m) derating 20 K	<ul style="list-style-type: none"> • 8 DI 24 V DC Source Input 	6AG1 131-4BF50-7AA0
		SIPLUS digital output modules	
		(extended temperature range and medial exposure)	
		Ordering unit 5 units	
		<ul style="list-style-type: none"> • 2 DO 24 V DC/0.5 A High Feature • 2 DO 24 V DC/2 A High Feature • 4 DO 24 V DC/0.5 A Standard • 4 DO 24 V DC/2 A Standard • 2 DO 24 V DC to 230 V AC/5 A relay, NO contact • 2 DO 24...48 V DC/5 A, 24...230 V AC/5 A relay, changeover contact 	6AG1 132-4BB01-2AB0 6AG1 132-4BB31-7AB0 6AG1 132-4BD02-7AA0 6AG1 132-4BD32-2AA0 6AG1 132-4HB01-2AB0
		Ordering unit 1 unit	
		<ul style="list-style-type: none"> • 8 DO 24 V DC/0.5 A Standard • 8 DO, 24 V DC / 0.5 A, standard SOURCE OUTPUT 	6AG1 132-4BF00-7AA0 6AG1 132-4BF50-7AA0
		Accessories	See SIMATIC ET 200S digital electronic module, page 9/87

For further technical documentation on SIPLUS, see:
<http://www.siemens.com/siplus-extreme>

SIMATIC ET 200 distributed I/O

ET 200S

I/O modules

Analog electronic modules

Overview



- Analog inputs and outputs for the ET 200S
- Can be plugged onto TM-E terminal modules with automatic coding
- High-feature variants with enhanced performance, precision and resolution
- High-speed variants with extremely fast, isochronous cycle times.
- Hot swapping of modules possible

Note:

Consult the configuring guide for selection of the appropriate TM-E terminal modules.

Technical specifications

	6ES7 134-4FB01-0AB0	6ES7 134-4LB02-0AB0	6ES7 134-4GB01-0AB0	6ES7 134-4GB52-0AB0
Supply voltage				
Load voltage L+				
• Rated value (DC)	24 V; From power module	24 V	24 V; From power module	24 V
• Short-circuit protection				Yes
• Reverse polarity protection	Yes	Yes	Yes; Destruction limit 35 mA per channel	Yes
Input current				
from load voltage L+ (without load), max.	30 mA	55 mA	80 mA	225 mA
from backplane bus 3.3 V DC, max.	10 mA	10 mA	10 mA	10 mA
Output voltage				
Power supply to the transmitters				
• present		No		Yes
• short-circuit proof				Yes
Power losses				
Power loss, typ.	0.6 W	0.85 W	0.6 W	2.5 W
Address area				
Address space per module				
• Address space per module, max.	4 byte	4 byte	4 byte	4 byte
Analog inputs				
Number of analog inputs	2	2	2	2
permissible input voltage for voltage input (destruction limit), max.	35 V; 35 V continuous; 75 V for max. 1 ms (mark to space ratio 1:20)	35 V; 35 V continuous; 75 V for max. 1 ms		
permissible input current for current input (destruction limit), max.			40 mA	
Cycle time (all channels) max.	Number of active channels per module x basic conversion time	0.5 ms; 0.5 ms for 2 channels without noise suppression, 18 / 21 ms per channel with noise suppression	Number of active channels per module x basic conversion time	0.25 ms
Input ranges				
• Voltage	Yes	Yes	No	No
• Current	No	No	Yes	Yes
• Thermocouple	No	No	No	No
• Resistance thermometer	No	No	No	No
• Resistance	No	No	No	No

Technical specifications (continued)

	6ES7 134-4FB01-0AB0	6ES7 134-4LB02-0AB0	6ES7 134-4GB01-0AB0	6ES7 134-4GB52-0AB0
Input ranges (rated values), voltages				
• 1 to 5 V	Yes	Yes		
• Input resistance (1 to 5 V)		800 kΩ		
• -10 V to +10 V	Yes	Yes		
• Input resistance (-10 V to +10 V)		800 kΩ		
• -5 V to +5 V	Yes	Yes		
• Input resistance (-5 V to +5 V)		800 kΩ		
Input ranges (rated values), currents				
• 0 to 20 mA				Yes
• Input resistance (0 to 20 mA)				106 Ω
• 4 to 20 mA			Yes; on 50 ohms	Yes
Cable length				
• Cable length, shielded, max.	200 m	200 m	200 m	200 m
Analog value creation				
Measurement principle	integrating		integrating	
Integrations and conversion time/ resolution per channel				
• Resolution with overrange (bit including sign), max.	14 bit; +/-10 V: 13 bits + sign, +/-5 V: 13 bits + sign; 1 to 5 V: 13 bits	16 bit; 0 to 5 V: 15 bits , +/-10 V: 16 bits, +/-5 V: 16 bits Yes	13 bit; 4 to 20 mA: 13 bits	16 bit
• Integration time, parameterizable				
• Integration time, ms	16.7 / 20 ms		16.7 / 20 ms	
• Interference voltage suppression for interference frequency f1 in Hz	60 / 50 Hz	60 / 50 Hz / no	60 / 50 Hz	
• Conversion time (per channel)	65 ms; 55 / 65 ms	0.04 ms; Without noise suppression 17/20 ms per channel with error	65 ms; 55 / 65 ms	
Smoothing of measured values				
• Parameterizable	Yes; In four stages by means of digital filtering	Yes; In 4 stages: 1 x, 4 x, 16 x, 32 x cycle time	Yes; In four stages by means of digital filtering	Yes
• Step: None	Yes; 1 x cycle time	Yes; 1 x	Yes; 1 x cycle time	Yes; 1
• Step: low	Yes; 4 x cycle time	Yes; 4 x	Yes; 4 x cycle time	Yes; 4
• Step: Medium	Yes; 32 x cycle time	Yes; 16 x	Yes; 32 x cycle time	Yes; 16
• Step: High	Yes; 64 x cycle time	Yes; 32 x	Yes; 64 x cycle time	Yes; 32
Encoder				
Connection of signal encoders		Yes		
• for voltage measurement				Yes
• for current measurement as 2-wire transducer				
• Burden of 2-wire transmitter, max.			750 Ω	
Errors/accuracies				
Linearity error (relative to input area)	+/- 0,01 %	+/- 0,01 %	+/- 0,01 %	+/- 0,03 %
Temperature error (relative to input area)	+/- 0,01 %/K	+/- 0,003 %/K	+/- 0,005 %/K	+/- 0,01 %/K
Crosstalk between the inputs, min.	-50 dB	-100 dB	-50 dB	50 dB
Repeat accuracy in settled status at 25 °C (relative to input area)	+/- 0,05 %	+/- 0,01 %	+/- 0,05 %	+/- 0,1 %
Operational limit in overall temperature range				
• Voltage, relative to input area	+/- 0,6 %	+/- 0,1 %; 0.2% without interference frequency suppression		
• Current, relative to input area			+/- 0,6 %	+/- 0,3 %

SIMATIC ET 200 distributed I/O

ET 200S

I/O modules

Analog electronic modules

Technical specifications (continued)

	6ES7 134-4FB01-0AB0	6ES7 134-4LB02-0AB0	6ES7 134-4GB01-0AB0	6ES7 134-4GB52-0AB0
Basic error limit (operational limit at 25 °C)				
• Voltage, relative to input area	+/- 0,4 %	+/- 0,05 %; 0.1% without interference frequency suppression		
• Current, relative to input area			+/- 0,4 %	+/- 0,2 %
Interference voltage suppression for $f = n \times (f1 +/- 1\%)$, $f1 =$ interference frequency				
• Series mode interference (peak value of interference < rated value of input range), min.	70 dB	90 dB	70 dB	
• common mode voltage (USS < 2.5 V), min.	90 dB	100 dB		
Isochronous mode				
Isochronous operation (application synchronized up to terminal)	No	Yes	No	Yes
Interrupts/diagnostics/status information				
Alarms				
• Hardware interrupt		Yes		Yes
Diagnostic messages				
• Diagnostic functions		Yes		Yes
• Wire break	Yes; Measuring range 1 to 5 V only	Yes; Measuring range 1 to 5 V only	Yes	Yes; at 4 to 20 mA
• Group error	Yes	Yes	Yes	Yes
• Overflow/underflow	Yes	Yes	Yes	Yes
Diagnostics indication LED				
• Group error SF (red)	Yes	Yes	Yes	Yes
Parameter				
Remark		12 bytes, 4 bytes in compatibility mode		
Diagnosis: wire break	Disable / enable (only in measuring range 1 to 5 V)			At 4 to 20 mA
Measurement type/range	deactivated / +/-5 V / 1 to 5 V / +/-10 V	deactivated / +/-5 V / 1 to 5 V / +/-10 V	deactivated / 4 to 20 mA	4 to 20 mA, 0 to 20 mA
Interference frequency suppression				No
Group diagnostics	Disable / enable	Disable / enable	Disable / enable	1
Overflow/underflow	Disable / enable	Disable / enable	Disable / enable	1
Galvanic isolation				
Galvanic isolation analog inputs				
• between the channels	No	No; however, increased permissible potential difference between the inputs.	No	No
• between the channels and the backplane bus	Yes	Yes	Yes	Yes
• between the channels and the load voltage L+	Yes	Yes	No	Yes
Permissible potential difference				
between the inputs (UCM)		140 V DC/100 V AC		
between inputs and MANA (UCM)	2 V AC PP			
between MANA and M internally (UISO)	75 VDC / 60 VAC			75 V DC, 60 V AC
Isolation				
Isolation checked with	500 V DC	500 V DC	500 V DC	
Dimensions				
Width	15 mm	15 mm	15 mm	15 mm
Module width, max.		15 mm		15 mm
Height	81 mm	81 mm	81 mm	81 mm
Depth	52 mm	52 mm	52 mm	52 mm
Weight				
Weight, approx.	40 g	45 g	40 g	

Technical specifications (continued)

	6ES7 134-4GB11-0AB0	6ES7 134-4MB02-0AB0	6ES7 134-4GD00-0AB0	6ES7 134-4FB52-0AB0	6ES7 134-4GB62-0AB0
Supply voltage					
Load voltage L+					
• Rated value (DC)	24 V; From power module	24 V	24 V; From power module	24 V	24 V
• Short-circuit protection		Yes	Yes	Yes	Yes
• Reverse polarity protection		Yes	Yes	Yes	Yes
Input current					
from load voltage L+ (without load), max.	30 mA	48 mA	125 mA	80 mA	80 mA; without load
from backplane bus 3.3 V DC, max.	10 mA	10 mA	10 mA	10 mA	10 mA
Output voltage					
Power supply to the transmitters					
• present		Yes	Yes		Yes
• short-circuit proof		Yes	Yes; approx. 200 mA for module		Yes
Encoder supply					
Number of outputs					2
Output voltage					24 V
Output current, rated value					90 mA; Per channel
Output current, permissible range					0 to 90 mA
Output current					
• Short-circuit protection					Yes
Power losses					
Power loss, typ.	0.6 W	1.2 W	0.6 W	1.9 W	1.9 W
Address area					
Address space per module					
• Address space per module, max.	4 byte	4 byte	8 byte	4 byte	4 byte
Analog inputs					
Number of analog inputs	2	2	4	2	2
permissible input voltage for voltage input (destruction limit), max.				35 V; Permanent	
permissible input current for current input (destruction limit), max.	40 mA	50 mA	30 mA; limited electronically		30 mA
Cycle time (all channels) max.	Number of active channels per module x basic conversion time	0.5 ms; 0.5 ms for 2 channels without noise suppression, 18 / 21 ms per channel with noise suppression	40 ms; 33 to 40 ms	250 μs	250 μs
Input ranges					
• Voltage	No	No	No	Yes	No
• Current	Yes	Yes	Yes	No	Yes
• Thermocouple	No	No	No	No	No
• Resistance thermometer	No	No	No	No	No
• Resistance	No	No	No	No	No
Input ranges (rated values), voltages					
• 1 to 5 V				Yes	
• Input resistance (1 to 5 V)				120 kΩ	
• -10 V to +10 V				Yes	
• Input resistance (-10 V to +10 V)				120 kΩ	
• -2.5 V to +2.5 V				Yes	
• Input resistance (-2.5 V to +2.5 V)				120 kΩ	
• -5 V to +5 V				Yes	
• Input resistance (-5 V to +5 V)				120 kΩ	

SIMATIC ET 200 distributed I/O

ET 200S

I/O modules

Analog electronic modules

Technical specifications (continued)

	6ES7 134-4GB11-0AB0	6ES7 134-4MB02-0AB0	6ES7 134-4GD00-0AB0	6ES7 134-4FB52-0AB0	6ES7 134-4GB62-0AB0
Input ranges (rated values), currents <ul style="list-style-type: none"> 0 to 20 mA Input resistance (0 to 20 mA) -20 to +20 mA 4 to 20 mA 	Yes; 50 ohms Yes; 50 ohms	Yes Yes	Yes; Into 25 Ohm		Yes 106 Ω Yes Yes
Cable length <ul style="list-style-type: none"> Cable length, shielded, max. 	200 m	200 m	200 m	200 m	200 m
Analog value creation					
Measurement principle	integrating	Sigma Delta	integrating		
Integrations and conversion time/ resolution per channel <ul style="list-style-type: none"> Resolution with overrange (bit including sign), max. Integration time, parameterizable Integration time, ms Interference voltage suppression for interference frequency f1 in Hz Conversion time (per channel) 	14 bit; +/-20 mA: 14 bits, 4 to 20 mA: 13 bits 16.7 / 20 ms 60 / 50 Hz 65 ms; 55 / 65 ms	16 bit; as required Yes 60 / 50 Hz / no 0.04 ms; Without noise suppression 17/20 ms per channel with error	13 bit; 4 to 20 mA: 13 bits Yes 16.67/20 ms 60 / 50 Hz	16 bit; 15 bits: 1 to 5 V; +/-2.5 V; 16 bits: +/-10 V; +/-5 V	16 bit
Smoothing of measured values <ul style="list-style-type: none"> Parameterizable Step: None Step: low Step: Medium Step: High 	Yes; In four stages by means of digital filtering Yes; 1 x cycle time Yes; 4 x cycle time Yes; 32 x cycle time Yes; 64 x cycle time	Yes; In 4 stages: 1 x, 4 x, 16 x, 32 x cycle time Yes; 1 x Yes; 4 x Yes; 16 x Yes; 32 x	Yes; in 4 stages Yes; 1 x cycle time Yes; 4 x cycle time Yes; 16 x cycle time Yes; 32 x cycle time	Yes Yes; 1 x cycle time Yes; 4 x cycle time Yes; 16 x cycle time Yes; 32 x cycle time	Yes Yes; 1 x cycle time Yes; 4 x cycle time Yes; 16 x cycle time Yes; 32 x cycle time
Encoder					
Connection of signal encoders <ul style="list-style-type: none"> for voltage measurement for current measurement as 2-wire transducer Burden of 2-wire transmitter, max. 	750 Ω	750 Ω	750 Ω	Yes	No
Errors/accuracies					
Linearity error (relative to input area)	+/- 0,01 %	+/- 0,03 %	+/- 0,01 %	+/- 0,03 %	+/- 0,03 %
Temperature error (relative to input area)	+/- 0,005 %/K	+/- 0,03 %/K	+/- 0,003 %/K	+/- 0,01 %/K	+/- 0,01 %/K
Crosstalk between the inputs, min.	-50 dB	-100 dB	-50 dB	-50 dB	-50 dB
Repeat accuracy in settled status at 25 °C (relative to input area)	+/- 0,05 %	+/- 0,01 %	+/- 0,05 %	+/- 0,1 %	+/- 0,1 %
Operational limit in overall temperature range <ul style="list-style-type: none"> Voltage, relative to input area Current, relative to input area 	+/- 0,6 %	+/- 0,1 %; 0.2% without interference frequency suppression	+/- 0,4 %	+/- 0,3 %	+/- 0,3 %
Basic error limit (operational limit at 25 °C) <ul style="list-style-type: none"> Voltage, relative to input area Current, relative to input area 	+/- 0,4 %	+/- 0,05 %; 0.1% without interference frequency suppression	+/- 0,3 %	+/- 0,2 %	+/- 0,2 %
Interference voltage suppression for f = n x (f1 +/- 1%), f1 = interference frequency <ul style="list-style-type: none"> Series mode interference (peak value of interference < rated value of input range), min. common mode voltage (USS < 2.5 V), min. 	70 dB	90 dB 100 dB	70 dB		

Technical specifications (continued)

	6ES7 134-4GB11-0AB0	6ES7 134-4MB02-0AB0	6ES7 134-4GD00-0AB0	6ES7 134-4FB52-0AB0	6ES7 134-4GB62-0AB0
Isochronous mode Isochronous operation (application synchronized up to terminal)	No	Yes	No	Yes	Yes
Interrupts/diagnostics/status information Alarms • Hardware interrupt		Yes		Yes	Yes
Diagnostic messages • Diagnostic functions • Diagnostic information readable • Wire break	Yes; Measuring range 4 to 20 mA only	Yes; Measuring range 4 to 20 mA only	Yes; Measuring range 1 to 5 V only	Yes; At 1 to 5 V	Yes; Only with measuring range 4 to 20 mA
• Group error • Overflow/underflow	Yes Yes	Yes Yes	Yes Yes	Yes Yes	Yes Yes
Diagnosics indication LED • Group error SF (red)	Yes	Yes	Yes	Yes	Yes
Parameter Remark		12 bytes, 4 bytes in compatibility mode		12 bytes, 4 bytes in compatibility mode	
Diagnosis: wire break	Disable / enable (only in measuring range 4 to 20 mA)	Disable / enable	1		At 4 to 20 mA
Measurement type/range	deactivated / +/-20 mA / 4 to 20 mA	deactivated / +/-20 mA / 4 to 20 mA	1	Deactivated / +/-5 V / 1 to 5 V / +/-10 V / +/-2.5 V	4 to 20 mA, 0 to 20 mA, +/-20 mA
Group diagnostics	Disable / enable	Disable / enable	1	Disable / enable	Yes
Overflow/underflow	Disable / enable	Disable / enable	1	Disable / enable	Yes
Galvanic isolation Galvanic isolation analog inputs • between the channels	No	No; however, increased permissible potential difference between the inputs.	No	No	No
• between the channels and the backplane bus	Yes	Yes	Yes	Yes	Yes
• between the channels and the load voltage L+	No	Yes	No	Yes	Yes
Permissible potential difference between MANA and M internally (UISO)					75 V DC, 60 V AC
Isolation Isolation checked with	500 V DC		500 V DC	500 V DC	
Dimensions Width	15 mm	15 mm	15 mm	15 mm	15 mm
Module width, max.		15 mm		15 mm	15 mm
Height	81 mm	81 mm	81 mm	81 mm	81 mm
Depth	52 mm	52 mm	52 mm	52 mm	52 mm
Weight Weight, approx.	40 g	45 g	40 g	45 g	45 g

SIMATIC ET 200 distributed I/O

ET 200S

I/O modules

Analog electronic modules

Technical specifications (continued)

	6ES7 134-4JB01-0AB0	6ES7 134-4JB51-0AB0	6ES7 134-4JD00-0AB0	6ES7 134-4NB01-0AB0	6ES7 134-4NB51-0AB0
Supply voltage					
Load voltage L+					
• Rated value (DC)	24 V; From power module	24 V; From power module	24 V; From power module	24 V; From power module	24 V; From power module
• Reverse polarity protection	Yes	Yes	Yes	Yes	Yes
Input current					
from load voltage L+ (without load), max.	30 mA	30 mA	30 mA	30 mA	30 mA
from backplane bus 3.3 V DC, max.	10 mA	10 mA	10 mA	10 mA	10 mA
Output voltage					
Power supply to the transmitters					
• present		Yes			
• short-circuit proof		Yes			
Power losses					
Power loss, typ.	0.6 W	0.6 W	0.6 W	0.6 W	0.6 W
Address area					
Address space per module					
• Address space per module, max.	4 byte	8 byte	8 byte	4 byte	4 byte
Analog inputs					
Number of analog inputs	2	4; 2 for 3 or 4-wire connection	4	2	2
permissible input voltage for voltage input (destruction limit), max.	10 V; Permanent	9 V	10 V; Permanent	20 V; +/-20 V, continuous	9 V
Constant measurement current for resistance-type transmitter, typ.		1.67 mA			1.25 mA
Cycle time (all channels) max.	Number of active channels per module x basic conversion time	Number of active channels per module x basic conversion time	Number of active channels per module x basic conversion time	Number of active channels per module x basic conversion time	Number of active channels per module x basic conversion time
Technical unit for temperature measurement adjustable	No	No	No	Yes	Yes
Input ranges					
• Voltage	Yes		Yes	Yes	Yes
• Current				No	No
• Thermocouple	Yes		Yes	Yes	Yes
• Resistance thermometer		Yes		No	Yes
• Resistance		Yes		No	Yes
Input ranges (rated values), voltages					
• -80 mV to +80 mV	Yes		Yes	Yes	
• Input resistance (-80 mV to +80 mV)	1 M Ω		1 M Ω	1 M Ω	
Input ranges (rated values), thermoelements					
• Type B	Yes		Yes	Yes	
• Input resistance (Type B)	1 M Ω		1 M Ω	1 M Ω	
• Type C				Yes	
• Input resistance (Type C)				1 M Ω	
• Type E	Yes		Yes	Yes	
• Input resistance (Type E)	1 M Ω		1 M Ω	1 M Ω	
• Type J	Yes		Yes	Yes	
• Input resistance (type J)	1 M Ω		1 M Ω	1 M Ω	
• Type K	Yes		Yes	Yes	
• Input resistance (Type K)	1 M Ω		1 M Ω	1 M Ω	
• Type L	Yes		Yes	Yes	
• Input resistance (Type L)	1 M Ω		1 M Ω	1 M Ω	
• Type N	Yes		Yes	Yes	
• Input resistance (Type N)	1 M Ω		1 M Ω	1 M Ω	
• Type R	Yes		Yes	Yes	
• Input resistance (Type R)	1 M Ω		1 M Ω	1 M Ω	
• Type S	Yes		Yes	Yes	
• Input resistance (Type S)	1 M Ω		1 M Ω	1 M Ω	
• Type T	Yes		Yes	Yes	
• Input resistance (Type T)	1 M Ω		1 M Ω	1 M Ω	

Technical specifications (continued)

	6ES7 134-4JB01-0AB0	6ES7 134-4JB51-0AB0	6ES7 134-4JD00-0AB0	6ES7 134-4NB01-0AB0	6ES7 134-4NB51-0AB0
Input ranges (rated values), resistance thermometers					
• Cu 10					Yes
• Input resistance (Cu 10)					10 MΩ
• Ni 100		Yes; Standard/climate			Yes
• Input resistance (Ni 100)		2 000 kΩ			10 MΩ
• Ni 1000					Yes
• Input resistance (Ni 1000)					10 MΩ
• Ni 120					Yes
• Input resistance (Ni 120)					10 MΩ
• Ni 200					Yes
• Input resistance (Ni 200)					10 MΩ
• Ni 500					Yes
• Input resistance (Ni 500)					10 MΩ
• Pt 100		Yes; Standard/climate			Yes
• Input resistance (Pt 100)		2 000 kΩ			10 MΩ
• Pt 1000					Yes
• Input resistance (Pt 1000)					10 MΩ
• Pt 200					Yes
• Input resistance (Pt 200)					10 MΩ
• Pt 500					Yes
• Input resistance (Pt 500)					10 MΩ
Input ranges (rated values), resistors					
• 0 to 150 ohms		Yes			Yes
• Input resistance (0 to 150 ohms)		2 000 kΩ			10 MΩ
• 0 to 300 ohms		Yes			Yes
• Input resistance (0 to 300 ohms)		2 000 kΩ			10 MΩ
• 0 to 600 ohms		Yes			Yes
• Input resistance (0 to 600 ohms)		2 000 kΩ			10 MΩ
• 0 to 3000 ohms					Yes
• Input resistance (0 to 3000 ohms)					10 MΩ
Thermocouple (TC)					
• for thermocouples				Type B, C, E, J, K, L, N, R, S, T to IEC 584	
• Temperature compensation					
- internal temperature compensation	Not possible		Not possible	Yes; possible with TM-E15S24-AT, TM-E15C24-AT	Yes
- external temperature compensation with compensations socket	Yes; possible, one external compensating box per channel		Yes; possible, one external compensating box per channel	Yes; one external compensating box per channel	
Resistance thermometer (RTD)					
• Characteristic linearization					
- for resistance thermometer		Pt100 (standard, climatic range), Ni100 (standard, climatic range)			Ptxxx, Nixxx
Characteristic linearization					
• Parameterizable	Yes; Type B, E, J, K, L, N, R, S, T to IEC 584	Yes; for Pt100, Ni100	Yes; Type B, E, J, K, L, N, R, S, T to IEC 584	Yes	Yes; for Ptxxx, Nixxx
Cable length					
• Cable length, shielded, max.	50 m	200 m	50 m	50 m	200 m

SIMATIC ET 200 distributed I/O

ET 200S

I/O modules

Analog electronic modules

Technical specifications (continued)

	6ES7 134-4JB01-0AB0	6ES7 134-4JB51-0AB0	6ES7 134-4JD00-0AB0	6ES7 134-4NB01-0AB0	6ES7 134-4NB51-0AB0
Analog value creation					
Measurement principle	integrating	integrating	integrating	integrating	integrating (Sigma-Delta)
Integrations and conversion time/ resolution per channel					
<ul style="list-style-type: none"> Resolution with overrange (bit including sign), max. 	16 bit; 15 bits + sign	16 bit; 150 ohms: 14 bits; 300, 600 ohms: 15 bits, Pt100, Ni100: 16 bits	16 bit; 15 bits + sign	16 bit	16 bit; for Pt100, Ni100, Ni120, Pt200, Ni200, Pt 500, Ni 500, Pt1000, Ni1000, Cu10: 15 bits + sign; for 150, 300, 600, 3000 ohms: 15 bits; for PTC: 1 bits
<ul style="list-style-type: none"> Integration time, parameterizable Integration time, ms Interference voltage suppression for interference frequency f1 in Hz Conversion time (per channel) 	Yes 16.7 / 20 ms 60 / 50 Hz 65 s; 55 / 65 ms (additional 20 ms on activated wire-break test)	Yes 16.7 / 20 ms 60 / 50 Hz 66 / 80 ms; additional conversion time for diagnostic wire break test	Yes 16.7 / 20 ms 60 / 50 Hz 65 ms; 55 / 65 ms (additional 20 ms on activated wire-break test)	16.7 / 20 ms 60 / 50 Hz 66 ms; 66 / 80 ms; additional conversion time for diagnostic wire break test	16.7 / 20 ms 60 / 50 Hz Basic conversion time incl. integration time: 50 / 60 ms; additional conversion time for diagnostics of wire break test: 5 / 5 ms; additional conversion time for line compensation with 3-wire connection: 50 / 60 ms
Smoothing of measured values					
<ul style="list-style-type: none"> Parameterizable Step: None Step: low Step: Medium Step: High 	Yes; In four stages by means of digital filtering Yes; 1 x cycle time Yes; 4 x cycle time Yes; 32 x cycle time Yes; 64 x cycle time	Yes; In four stages by means of digital filtering Yes; 1 x cycle time Yes; 4 x cycle time Yes; 32 x cycle time Yes; 64 x cycle time	Yes; In four stages by means of digital filtering Yes; 1 x cycle time Yes; 4 x cycle time Yes; 32 x cycle time Yes; 64 x cycle time	Yes; In four stages by means of digital filtering Yes; 1 x cycle time Yes; 4 x cycle time Yes; 32 x cycle time Yes; 64 x cycle time	Yes; In four stages by means of digital filtering Yes; 1 x cycle time Yes; 4 x cycle time Yes; 32 x cycle time Yes; 64 x cycle time
Encoder					
Connection of signal encoders					
<ul style="list-style-type: none"> for voltage measurement for resistance measurement with 2-conductor connection for resistance measurement with 3-conductor connection for resistance measurement with 4-conductor connection 	Yes	Yes Yes Yes	Yes		Yes Yes; internal compensation of the line resistances Yes
Errors/accuracies					
Linearity error (relative to input area)	+/- 0,01 %	+/- 0,01 %	+/- 0,01 %	+/- 0,01 %	+/- 0,01 %
Temperature error (relative to input area)	+/- 0,005 %/K	+/- 0,005 %/K	+/- 0,005 %/K	+/- 0,005 %/K	+/- 0,0009 %/K
Crosstalk between the inputs, min.	-50 dB	-50 dB	-50 dB	-50 dB	-50 dB
Repeat accuracy in settled status at 25 °C (relative to input area)	+/- 0,05 %	+/- 0,05 %	+/- 0,05 %	+/- 0,05 %	+/- 0,05 %

Technical specifications (continued)

	6ES7 134-4JB01-0AB0	6ES7 134-4JB51-0AB0	6ES7 134-4JD00-0AB0	6ES7 134-4NB01-0AB0	6ES7 134-4NB51-0AB0
Operational limit in overall temperature range • Voltage, relative to input area	+/- 0,6 %		+/- 0,6 %	+/- 0,1 %; +/-1.5 K for thermocouples, +/-7 K for thermocouples type C, +/-2.5 K with static thermal state (ambient temperature change < 0.3 K/min)	
• Resistance-type thermometer, relative to input area		+/- 0,6 %			Resistance-type transmitter: +/-0.1%; Pt100, Pt200, Pt500, Pt1000 standard: +/-1.0 K; Pt100, Pt200, Pt500, Pt1000 climate: +/-0.25 K; Ni100, Ni120, Ni200, Ni500, Ni1000 standard and climate: +/-0.4 K; Cu10 +/-1.5 K
Basic error limit (operational limit at 25 °C) • Voltage, relative to input area	+/- 0,4 %		+/- 0,4 %	+/- 0,05 %; +/-1 K with thermocouples, +/-5 K with thermocouples type C, +/-1.5 K with static thermal state (ambient temperature change < 0.3 K/min)	
• Resistance-type thermometer, relative to input area		+/- 0,4 %			Resistance-type transmitter: +/-0.05%; Pt100, Pt200, Pt500, Pt1000 standard: +/-0.6 K; Pt100, Pt200, Pt500, Pt1000 climate: +/-0.13 K; Ni100, Ni120, Ni200, Ni500, Ni1000 standard and climate: +/-0.2 K; Cu10 +/-1 K
Interference voltage suppression for $f = n \times (f_l \pm 1\%)$, f_l = interference frequency • Series mode interference (peak value of interference < rated value of input range), min.	70 dB	70 dB	70 dB	70 dB	70 dB
• common mode voltage (USS < 2.5 V), min.	90 dB	90 dB	90 dB	90 dB	90 dB
Isochronous mode Isochronous operation (application synchronized up to terminal)	No	No	No		No
Interrupts/diagnostics/status information Diagnostic messages • Diagnostic functions • Diagnostic information readable • Wire break	Yes; Can be read out Yes Yes; A break in the wire is only detected for thermocouples	Yes; Can be read out Yes	Yes; Can be read out Yes Yes; A break in the wire is only detected for thermocouples	Yes; Can be read out Yes Yes; A break in the wire is only detected for thermocouples	Yes Yes Yes
• Group error • Overflow/underflow	Yes Yes	Yes Yes	Yes Yes	Yes Yes	Yes Yes
Diagnosics indication LED • Group error SF (red)	Yes	Yes	Yes	Yes	Yes

SIMATIC ET 200 distributed I/O

ET 200S

I/O modules

Analog electronic modules

Technical specifications (continued)

	6ES7 134-4JB01-0AB0	6ES7 134-4JB51-0AB0	6ES7 134-4JD00-0AB0	6ES7 134-4NB01-0AB0	6ES7 134-4NB51-0AB0
Parameter					
Diagnosis: wire break	Disable / enable (wire break is detected only in thermocouples)	Disable / enable	Disable / enable (wire break is detected only in thermocouples)	Disable / enable (wire break is detected only in thermocouples)	Disable / enable
Measurement type/range	Deactivated/ +/- 80 mV/ TC-EL Type T (Cu-CuNi)/ TC-EL Type K (NiCr-Ni)/ TC-EL Type B (PtRh-PtRh)/ TC-EL Type c (Wer-Wer) TC-EL Type N (NiCrSi-NiSi)/ TC-EL Type E (NiCr-CuNi)/ TC-EL Type R (PtRh-Pt)/ TC-EL Type S (PtRh-Pt)/ TC-EL Type J (Fe-Cu-Ni)/ TC	deactivated/ 150 ohms/; 300 ohms/600 ohms/ Pt100 climatic/ Pt100 standard; Ni100 standard / Ni100 climatic, 2, 3 or 4-wire	Deactivated/ +/- 80 mV/ TC-EL Type T (Cu-CuNi)/ TC-EL Type K (NiCr-Ni)/ TC-EL Type B (PtRh-PtRh)/ TC-EL Type c (Wer-Wer) TC-EL Type N (NiCrSi-NiSi)/ TC-EL Type E (NiCr-CuNi)/ TC-EL Type R (PtRh-Pt)/ TC-EL Type S (PtRh-Pt)/ TC-EL Type J (Fe-Cu-Ni)/ TC	Deactivated/ +/- 80 mV/ TC-EL Type T (Cu-CuNi)/TC-EL Type K (NiCr-Ni)/ TC-EL Type B (PtRh-PtRh)/ TC-EL Type c (Wer-Wer) TC-EL Type N (NiCrSi-NiSi)/ TC-EL Type E (NiCr-CuNi)/ TC-EL Type R (PtRh-Pt)/ TC-EL Type S (PtRh-Pt)/ TC-EL Type J (Fe-Cu-Ni)/ TC	Deactivated/ 150 Ohm / 300 Ohm / 600 Ohm /Pt100/ Pt200/Pt500/Pt1000 each standard or cli- mate range / Ni100/ Ni120/Ni200/Ni500/ Ni1000 each stan- dard or climate range / Cu10 each standard or climate range / PTC
Group diagnostics	Disable / enable	Disable / enable	Disable / enable	Disable / enable	Disable / enable
Overflow/underflow	Disable / enable	Disable / enable	Disable / enable	Disable / enable	Disable / enable
Comparison point	none / RTD		none / RTD	none / yes, internal	
Comparison point number	None / 1 / 2 / 3 / 4 / 5 / 6 / 7 / 8		None / 1 / 2 / 3 / 4 / 5 / 6 / 7 / 8		
Unit	Celsius		Celsius	Celsius / Fahrenheit	
Galvanic isolation					
Galvanic isolation analog inputs					
• between the channels	No	No	No	No	No
• between the channels and the backplane bus	Yes	Yes	Yes	Yes	Yes
• between the channels and the load voltage L+	Yes	Yes	Yes	Yes	Yes
Permissible potential difference					
between inputs and MANA (UCM)	2 V AC PP		2 V AC PP	140 V DC/100 V AC	
between MANA and M internally (UISO)	75 VDC / 60 VAC	75 VDC / 60 VAC	75 VDC / 60 VAC	75 VDC / 60 VAC	75 VDC / 60 VAC
Isolation					
Isolation checked with	500 V DC	500 V DC	500 V DC	500 V DC	500 V DC
Dimensions					
Width	15 mm	15 mm	15 mm	15 mm	15 mm
Height	81 mm	81 mm	81 mm	81 mm	81 mm
Depth	52 mm	52 mm	52 mm	52 mm	52 mm
Weight					
Weight, approx.	40 g	40 g	40 g	40 g	40 g

Technical specifications (continued)

	6ES7 135-4FB01-0AB0	6ES7 135-4FB52-0AB0	6ES7 135-4LB02-0AB0
Supply voltage			
Load voltage L+			
• Rated value (DC)	24 V; From power module	24 V; From power module	24 V
• Reverse polarity protection	Yes	Yes	Yes
Input current			
from load voltage L+ (without load), max.	130 mA	100 mA	80 mA
from backplane bus 3.3 V DC, max.	10 mA	10 mA	10 mA
Power losses			
Power loss, max.	2 W	2 W	1.2 W
Address area			
Address space per module			
• Address space per module, max.	4 byte	4 byte	4 byte
Analog outputs			
Number of analog outputs	2	2	2
Voltage output, short-circuit protection	Yes	Yes	Yes
Voltage output, short-circuit current, max.	25 mA	25 mA	25 mA
Cycle time (all channels) max.	1.5 ms	0.25 ms	0.5 ms; At max. 0.5 µF
Output ranges, voltage			
• 1 to 5 V	Yes	Yes	Yes; -5 to +5 V also implemented
• -10 to +10 V	Yes	Yes; +/-5V as well	Yes
Connection of actuators			
• for voltage output 2-conductor connection	Yes; Without compensation of the line resistances	Yes; Without compensation of the line resistances	Yes
• for voltage output 4-conductor connection	Yes	Yes	Yes
Load impedance (in rated range of output)			
• with voltage outputs, min.	1 kΩ	1 kΩ	1 kΩ
• with voltage outputs, capacitive load, max.	1 µF	1 µF; 0.1 µF for Twa=0.1 ms	0.5 µF
Destruction limits against externally applied voltages and currents			
• Voltages at the outputs towards MANA	15 V; max. 15 V continuous; 75 V for max. 1 s (mark to space ratio 1:20)	15 V; Max. 15 V for max. 5 hours, 75 V for max. 1 s	15 V; as required
• Current, max.	50 mA; DC	30 mA; DC	
Cable length			
• Cable length, shielded, max.	200 m	200 m; Max. 20 m for TWA 100 µs	200 m; 100m if Twa < 2ms
Analog value creation			
Integrations and conversion time/ resolution per channel			
• Resolution with overrange (bit including sign), max.	14 bit; 1 to 5 V: 12 bits, +/-10 V: 13 bits + sign	16 bit; 1 to 5 V: 14 bits, +/-10 V: 15 bit + sign, +/-5 V: 14 bits + sign	16 bit; 15 bits + sign
Settling time			
• for resistive load	0.1 ms	0.05 ms	0.2 ms
• for capacitive load	0.5 ms	0.05 ms	0.5 ms; At max. 0.5 µF
• for inductive load	0.5 ms	0.05 ms	0.5 ms
Errors/accuracies			
Output ripple (based on output area, bandwidth 0 to 50 kHz)	+/- 0,02 %	+/- 0,02 %	+/- 0,02 %
Linearity error (relative to output area)	+/- 0,02 %	+/- 0,03 %	+/- 0,01 %
Temperature error (relative to output area)	+/- 0,01 %/K	+/- 0,01 %/K	
Crosstalk between the outputs, min.		60 dB	60 dB
Repeat accuracy in settled status at 25 °C (relative to output area)	+/- 0,05 %	+/- 0,03 %	+/- 0,01 %

SIMATIC ET 200 distributed I/O

ET 200S

I/O modules

Analog electronic modules

Technical specifications (continued)

	6ES7 135-4FB01-0AB0	6ES7 135-4FB52-0AB0	6ES7 135-4LB02-0AB0
Operational limit in overall temperature range			
• Voltage, relative to output area	+/- 0,4 %	+/- 0,2 %	+/- 0,1 %
Basic error limit (operational limit at 25 °C)			
• Voltage, relative to output area	+/- 0,2 %	+/- 0,01 %	+/- 0,05 %
Isochronous mode			
Isochronous operation (application synchronized up to terminal)		Yes	Yes
Interrupts/diagnostics/ status information			
Substitute values connectable	Yes; 0 to 65535 (range of values must be within the rated range)	Yes; 0 to 65535 (range of values must be within the rated range)	Yes
Diagnostic messages			
• Diagnostic functions		Yes	
• Diagnostic information readable		Yes	Yes
• Wire break		No	
• Short circuit	Yes	Yes	Yes
• Group error	Yes	Yes	Yes
Diagnostics indication LED			
• Group error SF (red)	Yes	Yes	Yes
Parameter			
Remark	7 bytes	7	7 bytes
Output type/range	deactivated / 1 to 5 V / +/- 10 V	deactivated / 1 to 5 V / +/- 10 V / +/- 5 V	deactivated / 1 to 5 V / +/- 10 V / +/- 5 V
Diagnosis: short circuit	Disable / enable	Disable / enable	Disable / enable
Interference frequency suppression			No
Group diagnostics	Disable / enable	Disable / enable	Disable / enable
Behavior on CPU/Master STOP	Output current and de-energized/ substitute a value/keep last value	Output current and de-energized/ substitute a value/keep last value	Output current and de-energized/ substitute a value/keep last value
Galvanic isolation			
Galvanic isolation analog outputs			
• between the channels	No	No	No
• between the channels and the backplane bus	Yes	Yes	Yes
• between the channels and the load voltage L+	Yes	Yes	Yes
Permissible potential difference between MANA and M internally (UISO)	75 VDC / 60 VAC	75 VDC / 60 VAC	75 VDC / 60 VAC
Isolation			
Isolation checked with			500 V DC
Dimensions			
Width	15 mm	15 mm	15 mm
Height	81 mm	81 mm	81 mm
Depth	52 mm	52 mm	52 mm
Weight			
Weight, approx.	40 g	40 g	40 g

Technical specifications (continued)

	6ES7 135-4GB01-0AB0	6ES7 135-4MB02-0AB0	6ES7 135-4GB52-0AB0
Supply voltage			
Load voltage L+			
• Rated value (DC)	24 V; From power module	24 V	24 V
• Reverse polarity protection	Yes	Yes	Yes
Input current			
from load voltage L+ (without load), max.	150 mA	80 mA	150 mA; With load
from backplane bus 3.3 V DC, max.	10 mA	10 mA	10 mA
Power losses			
Power loss, max.	2 W	1.2 W	2.4 W; Typical
Address area			
Address space per module			
• Address space per module, max.	4 byte	4 byte	4 byte
Analog outputs			
Number of analog outputs	2	2	2
Current output, no-load voltage, max.	18 V	18 V	18 V
Cycle time (all channels) max.	1.5 ms	0.5 ms	250 µs
Output ranges, current			
• -20 to +20 mA	Yes	Yes	Yes
• 4 to 20 mA	Yes	Yes	Yes
Connection of actuators			
• for current output 2-conductor connection	Yes	Yes	Yes
• for current output 4-conductor connection	No	No	
Load impedance (in rated range of output)			
• with current outputs, max.	500 Ω	500 Ω	500 Ω
• with current outputs, inductive load, max.	1 mH	1 mH	1 mH; for TWA 100µs
Destruction limits against externally applied voltages and currents			
• Voltages at the outputs towards MANA	15 V; max. 15 V continuous; 75 V for max. 1 s (mark to space ratio 1:20)		
• Current, max.	50 mA; DC	50 mA	15 mA; Max. 15 V / 5 hours (higher voltages not permissible even briefly)
Cable length			
• Cable length, shielded, max.	200 m	200 m; 100m if Twa < 2ms	200 m; Max. 20 m for TWA 100 µs
Analog value creation			
Integrations and conversion time/ resolution per channel			
• Resolution with overrange (bit including sign), max.	14 bit; 4 to 20 mA: 13 bits, +/-20 mA: 14 bits	16 bit	16 bit
Settling time			
• for resistive load	0.1 ms	0.3 ms	0.05 ms
• for capacitive load	0.5 ms	1 ms	0.05 ms; at a load of up to 500 ohms/ 100 nF and a max. cable length of 20 m
• for inductive load	0.5 ms	0.5 ms	0.05 ms
Errors/accuracies			
Output ripple (based on output area, bandwidth 0 to 50 kHz)	+/- 0,02 %	+/- 0,02 %	+/- 0,02 %
Linearity error (relative to output area)	+/- 0,02 %	+/- 0,01 %	+/- 0,03 %; with resistive load
Temperature error (relative to output area)	+/- 0,01 %/K	+/- 0,003 %/K	+/- 0,01 %/K
Crosstalk between the outputs, min.		60 dB	-60 dB
Repeat accuracy in settled status at 25 °C (relative to output area)	+/- 0,05 %	+/- 0,01 %	+/- 0,03 %

SIMATIC ET 200 distributed I/O

ET 200S

I/O modules

Analog electronic modules

Technical specifications (continued)

	6ES7 135-4GB01-0AB0	6ES7 135-4MB02-0AB0	6ES7 135-4GB52-0AB0
Operational limit in overall temperature range			
• Current, relative to output area	+/- 0,5 %	+/- 0,1 %	+/- 0,2 %; Specified value applies to loads from 200 to 350 Ohm, deviating operational limits for loads up to 200 Ohm and from 350 to 500 Ohm with up to 0.4%
Basic error limit (operational limit at 25 °C)			
• Current, relative to output area	+/- 0,3 %	+/- 0,05 %	+/- 0,1 %; Specified value applies for loads from 200 to 350 ohms, deviating basic error limits for loads up to 200 ohms and from 350 to 500 ohms with up to 0.3%
Isochronous mode			
Isochronous operation (application synchronized up to terminal)		Yes	Yes
Interrupts/diagnostics/status information			
Substitute values connectable	Yes; 0 to 65535 (range of values must be within the rated range)	Yes	Yes
Diagnostic messages			
• Diagnostic functions			Yes
• Diagnostic information readable		Yes	Yes
• Wire break	Yes	Yes	Yes
• Group error	Yes	Yes	Yes
Diagnostics indication LED			
• Group error SF (red)	Yes	Yes	Yes
Parameter			
Remark	7 bytes	7 bytes	7 bytes
Output type/range	deactivated / +/-20 mA / 4 to 20 mA	deactivated / +/-20 mA / 4 to 20 mA	deactivated / +/-20 mA / 4 to 20 mA
Diagnosis: wire break	Disable / enable	Disable / enable	Disable / enable
Interference frequency suppression		Disable / enable	
Group diagnostics	Disable / enable	Disable / enable	Disable / enable
Behavior on CPU/Master STOP	Output current and de-energized/ substitute a value/keep last value	Output current and de-energized/ substitute a value/keep last value	Output current and de-energized/ substitute a value/keep last value
Ex(i) characteristics			
Max. values of output circuits (per channel)			
• U _o (output no-load voltage), max.	18 V		
Galvanic isolation			
Galvanic isolation analog outputs			
• Galvanic isolation analog outputs		Yes	Yes
• between the channels	No	No	No
• between the channels and the backplane bus	Yes	Yes	Yes
• between the channels and the load voltage L+	Yes	Yes	Yes
Permissible potential difference			
between MANA and M internally (UISO)	75 VDC / 60 VAC	75 VDC / 60 VAC	75 VDC / 60 VAC
Isolation			
Isolation checked with		500 V DC	500 V DC
Dimensions			
Width	15 mm	15 mm	15 mm
Height	81 mm	81 mm	81 mm
Depth	52 mm	52 mm	52 mm
Weight			
Weight, approx.	40 g	40 g	45 g

Ordering data	Order No.		Order No.
Analog input modules		Accessories for labeling	
Ordering unit 1 item		Label sheets DIN A4 (10 pieces)	
• 2 AI U High Speed	6ES7 134-4FB52-0AB0	Each sheet contains 60 labeling strips for peripheral modules and 20 labeling strips for interface modules	
• 2 AI U Standard	6ES7 134-4FB01-0AB0	• petrol	6ES7 193-4BH00-0AA0
• 2 AI U High Feature	6ES7 134-4LB02-0AB0	• red	6ES7 193-4BD00-0AA0
• 2 AI I Standard 2-wire	6ES7 134-4GB01-0AB0	• yellow	6ES7 193-4BB00-0AA0
• 2 AI I High Speed 2-wire	6ES7 134-4GB52-0AB0	• light beige	6ES7 193-4BA00-0AA0
• 2 AI High Speed 4-wire	6ES7 134-4GB62-0AB0		
• 2 AI I Standard 4-wire	6ES7 134-4GB11-0AB0	Accessories for system-integrated shield connection	
• 2 AI I High Feature 2-wire/4-wire (15 bits + sign)	6ES7 134-4MB02-0AB0	Shield connection element	6ES7 193-4GA00-0AA0
• 2 AI RTD standard	6ES7 134-4JB51-0AB0	Ordering unit 5 items	
• 2 AI TC Standard	6ES7 134-4JB01-0AB0	For plugging into TM-E and TM-P	
• 2 AI RTD High Feature	6ES7 134-4NB51-0AB0	Shield clamps	6ES7 193-4GB00-0AA0
• 2 AI TC High Feature	6ES7 134-4NB01-0AB0	Ordering unit 5 items	
• 4 AI Standard 2-wire	6ES7 134-4GD00-0AB0	For 3 × 10 mm busbars	
• 4 AI TC Standard	6ES7 134-4JD00-0AB0	Grounding terminal	8WA2 868
		Ordering unit 1 item	
Analog output modules		For cable cross-sections up to 25 mm ²	
Ordering unit 1 item		3 × 10 mm busbars	8WA2 842
• 2 AO U Standard	6ES7 135-4FB01-0AB0	Ordering unit 1 item	
• 2 AO U High Speed	6ES7 135-4FB52-0AB0		
• 2 AO U High Feature	6ES7 135-4LB02-0AB0		
• 2 AO I Standard	6ES7 135-4GB01-0AB0		
• 2 AO I High Speed	6ES7 135-4GB52-0AB0		
• 2 AO I High Feature	6ES7 135-4MB02-0AB0		

SIMATIC ET 200 distributed I/O

ET 200S

I/O modules SIPLUS analog electronic modules

Overview



- Analog inputs and outputs for the ET 200S
- Can be plugged onto TM-E terminal modules with automatic coding
- High-speed variants with extremely short isochronous cycle times
- Hot swapping of modules possible

Notes:

Consult the configuring guide for selection of the appropriate TM-E terminal modules.

SIPLUS extreme products are based on Siemens Industry standard products. The contents listed here were taken from the respective standard products. SIPLUS extreme-specific information was added.

SIPLUS analog electronic module 2 AI U Standard

Order No.	6AG1 134-4FB01-2AB0
Order No. based on	6ES7 134-4FB01-0AB0

Ambient temperature range	-25 ... +60 °C
Ambient conditions	Suitable for exceptional medial exposure (e.g. in sulfur chloride atmosphere).
Technical data	The technical data are identical with those of the based-on modules.

SIPLUS analog electronic module 2 AI I Standard 2-wire

Order No.	6AG1 134-4GB01-2AB0
Order No. based on	6ES7 134-4GB01-0AB0

Ambient temperature range	-25 ... +60 °C
Ambient conditions	Suitable for exceptional medial exposure (e.g. in sulfur chloride atmosphere).
Technical data	The technical data are identical with those of the based-on modules.

SIPLUS analog electronic module 2 AI I Standard 4-wire

Order No.	6AG1 134-4GB11-2AB0
Order No. based on	6ES7 134-4GB11-0AB0

Ambient temperature range	-25 ... +60 °C
Ambient conditions	Suitable for exceptional medial exposure (e.g. in sulfur chloride atmosphere).
Technical data	The technical data are identical with those of the based-on modules.

SIPLUS analog electronic module 2 AI I High Feature

Order No.	6AG1 134-4MB02-2AB0
Order No. based on	6ES7 134-4MB02-0AB0

Ambient temperature range	-25 ... +70 °C
Ambient conditions	Suitable for exceptional medial exposure (e.g. in sulfur chloride atmosphere).
Technical data	The technical data are identical with those of the based-on modules.

SIPLUS analog electronic module 2 AI High Speed

Order No.	6AG1 134-4GB52-2AB0
Order No. based on	6ES7 134-4GB52-0AB0

Ambient temperature range	-25 ... +60 °C
Ambient conditions	Suitable for exceptional medial exposure (e.g. in sulfur chloride atmosphere).
Technical data	The technical data are identical with those of the based-on modules.

SIPLUS analog electronic module 4 AI I Standard 2-wire

Order No.	6AG1 134-4GD00-2AB0
Order No. based on	6ES7 134-4GD00-0AB0

Ambient temperature range	-25 ... +70 °C
Ambient conditions	Suitable for exceptional medial exposure (e.g. in sulfur chloride atmosphere).
Technical data	The technical data are identical with those of the based-on modules.

SIPLUS analog electronic module 2 AI RTD

Order No.	6AG1 134-4JB51-7AB0
Order No. based on	6ES7 134-4JB51-0AB0

Ambient temperature range	-25 ... +60 °C
Ambient conditions	Suitable for exceptional medial exposure (e.g. in sulfur chloride atmosphere).
Technical data	The technical data are identical with those of the based-on modules.

Overview (continued)

SIPLUS analog electronic module 2 AI RTD High Feature	
Order No.	6AG1 134-4NB51-2AB0
Order No. based on	6ES7 134-4NB51-0AB0
Ambient temperature range	-25 ... +60 °C
Ambient conditions	Suitable for exceptional medial exposure (e.g. in sulfur chloride atmosphere).
Technical data	The technical data are identical with those of the based-on modules.

SIPLUS analog electronic module 2 AI TC High Feature	
Order No.	6AG1 134-4NB01-7AB0
Order No. based on	6ES7 134-4NB01-0AB0
Ambient temperature range	0 ... +70 °C
Ambient conditions	Suitable for exceptional medial exposure (e.g. in sulfur chloride atmosphere).
Technical data	The technical data are identical with those of the based-on modules.

SIPLUS analog electronic module 2 AO U Standard	
Order No.	6AG1 135-4FB01-2AB0
Order No. based on	6ES7 135-4FB01-0AB0
Ambient temperature range	-25 ... +60 °C
Ambient conditions	Suitable for exceptional medial exposure (e.g. in sulfur chloride atmosphere).
Technical data	The technical data are identical with those of the based-on modules.

SIPLUS analog electronic module 2 AO U High Feature	
Order No.	6AG1 135-4LB02-7AB0
Order No. based on	6ES7 135-4LB02-0AB0
Ambient temperature range	-25 ... +60 °C
Ambient conditions	Suitable for exceptional medial exposure (e.g. in sulfur chloride atmosphere).
Technical data	The technical data are identical with those of the based-on modules.

SIPLUS analog electronic module 2 AO I Standard	
Order No.	6AG1 135-4GB01-2AB0
Order No. based on	6ES7 135-4GB01-0AB0
Ambient temperature range	-25 ... +70 °C
Ambient conditions	Suitable for exceptional medial exposure (e.g. in sulfur chloride atmosphere).
Technical data	The technical data are identical with those of the based-on modules.

Ambient conditions	
Relative humidity	100%, condensation/frost permissible. No commissioning if condensation present.
Biologically active substances, compliance with EN 60721-3-3	Class 3B2 mold and fungal spores (excluding fauna). The supplied plug covers must remain in place over the unused interfaces during operation!
Chemically active substances, compliance with EN 60721-3-3	Class 3C4 incl. salt spray in accordance with EN60068-2-52 (degree of severity 3). The supplied plug covers must remain in place over the unused interfaces during operation!
Mechanically active substances, compliance with EN 60721-3-3	Class 3S4 incl. sand, dust. The supplied plug covers must remain in place over the unused interfaces during operation!
Air pressure (depending on the highest positive temperature range specified)	1080 ... 795 hPa (-1000 ... +2000 m) see ambient temperature range 795 ... 658 hPa (+2000 ... +3500 m) derating 10 K 658 ... 540 hPa (+3500 ... +5000 m) derating 20 K

For further technical documentation on SIPLUS, see:
<http://www.siemens.com/siplus-extreme>

Ordering data

Order No.

SIPLUS analog input modules

(extended temperature range and medial exposure)

- 2 AI U Standard
- 2 AI I Standard 2-wire
- 2 AI I Standard 4-wire
- 2 AI I High Feature 2-wire/4-wire (15 bits + sign)
- 2 AI High Speed 2-wire
- 4 AI Standard 2-wire
- 2 AI RTD Standard
- 2 AI RTD High Feature
- 2 AI TC High Feature

6AG1 134-4FB01-2AB0
6AG1 134-4GB01-2AB0
6AG1 134-4GB11-2AB0
6AG1 134-4MB02-2AB0

6AG1 134-4GB52-2AB0
6AG1 134-4GD00-2AB0
6AG1 134-4JB51-7AB0
6AG1 134-4NB51-2AB0
6AG1 134-4NB01-7AB0

SIPLUS analog output modules

- 2 AO U Standard
- 2 AO U High Feature
- 2 AO I Standard

6AG1 135-4FB01-2AB0
6AG1 135-4LB02-7AB0
6AG1 135-4GB01-2AB0

Accessories

See SIMATIC ET 200S analog electronic modules, page 9/105

SIMATIC ET 200 distributed I/O

ET 200S

Technology modules
SSI module

Overview



- 1-channel module for connecting SSI sensors to the ET 200S
- For position decoding and simple positioning tasks
- With two comparison operations with specifiable comparison values (standard mode)
- With a digital input for latching actual values (standard mode)
- Can be plugged into TM-E terminal module with automatic coding
- Fast mode for high-speed acquisition of encoder values (e.g. for drive controls)
- Module replacement possible during operation and when live (hot swapping)
- Simple parameterization without additional software

Note:

We supply positioning systems and prepared connection cables for counting and positioning functions as SIMODRIVE Sensors or Motion Connect 500 (also visit <http://www.siemens.com/simatic-technology>)

Technical specifications

6ES7 138-4DB03-0AB0	
Supply voltage	
Load voltage L+	
• Rated value (DC)	24 V
• permissible range, lower limit (DC)	20.4 V
• permissible range, upper limit (DC)	28.8 V
• Reverse polarity protection	Yes
Input current	
from load voltage L+ (without load), max.	40 mA
Encoder supply	
24 V encoder supply	
• 24 V	Yes
• Short-circuit protection	Yes
• Output current, max.	500 mA
Absolute encoder (SSI) encoder supply	
• Absolute encoder (SSI)	Yes
• Output voltage	L+ (-0.8 V)
• Output current, max.	500 mA
• Short-circuit protection	Yes
Power losses	
Power loss, typ.	1 W
Hardware configuration	
Module exchange	
• Hot swapping the IM-DP	Yes
• Module exchange under process voltage	Yes
Digital inputs	
Number/binary inputs	1
Input voltage	
• for signal "0"	-30 to +5 V
• for signal "1"	11 to 30 V
Input current	
• for signal "0", max. (permissible quiescent current)	2 mA
• for signal "1", typ.	9 mA
Cable length	
• Cable length, shielded, max.	50 m

6ES7 138-4DB03-0AB0	
Encoder	
Number of connectable encoders, max.	1
Connectable encoders	
• Absolute encoder (SSI)	Yes
Encoder signals, absolute encoder (SSI)	
• Message frame length, parameterizable	13, 14, 16, 21, 24 & 25 bit
• Binary code	Yes
• Gray code	Yes
• Cable length, shielded, max.	320 m; At 125 kHz
• Monoflop time	16/32/48/64 μs
Interrupts/diagnostics/status information	
Diagnostics indication LED	
• Group error SF (red)	Yes
• Status indicator digital input (green)	Yes
• Status indicator backward counting (green)	Yes
• Status indicator forward counting (green)	Yes
Galvanic isolation	
Galvanic isolation digital inputs	
• Galvanic isolation digital inputs	No; same potential with L+ and SSI
Galvanic isolation counter	
• between the channels and the backplane bus	Yes
• between the channels and the load voltage L+	No
Dimensions	
Width	15 mm
Height	81 mm
Depth	52 mm
Weight	
Weight, approx.	40 g

Ordering data	Order No.		Order No.
SSI module For connecting absolute encoders with an SSI interface	6ES7 138-4DB03-0AB0	Accessories Label sheets DIN A4 (10 pieces) Each sheet contains 60 labeling strips for peripheral modules and 20 labeling strips for interface modules <ul style="list-style-type: none"> • petrol • red • yellow • light beige Signal cable Preassembled for SSI absolute encoder 6FX2001-5, without D-Sub connector, UL/DESINA For length code, see page 5/114	 6ES7 193-4BH00-0AA0 6ES7 193-4BD00-0AA0 6ES7 193-4BB00-0AA0 6ES7 193-4BA00-0AA0 6FX5 002-2CC12-....

SIMATIC ET 200 distributed I/O

ET 200S

Technology modules

2 PULSE pulse generator

Overview



- 2-channel pulse generator and timer module for ET 200S
- For controlling final control elements, valves, heating elements, etc.
- Pulse-width modulation (PWM)
- Pulse trains
- Pulse chains
- Frequency output
- Time-precise switching signals to 24 V DC output
- Measurement of output current
- Isochronous mode

Technical specifications

6ES7 138-4DD01-0AB0	
Supply voltage	
Load voltage L+	24 V; From power module
• Rated value (DC)	Yes
• Reverse polarity protection	Yes
Input current	
from load voltage L+ (without load), max.	40 mA
from backplane bus 3.3 V DC, max.	10 mA
Encoder supply	
Output voltage	L+ (-0.8 V)
Output current, rated value	500 mA
Output current	
• Short-circuit protection	Yes
Power losses	
Power loss, typ.	1.8 W
Digital inputs	
Number/binary inputs	2
Input characteristic curve acc. to IEC 61131, Type 2	Yes
Input voltage	
• Rated value, DC	24 V
• for signal "0"	-30 to +5 V
• for signal "1"	11 to 30 V
Input current	
• for signal "1", typ.	9 mA
Input delay (for rated value of input voltage)	
• Input frequency (with a time delay of 0.1 ms), max.	20 kHz
• Minimum pulse width for program reactions	100 µs
Cable length	
• Cable length, shielded, max.	100 m

6ES7 138-4DD01-0AB0	
Digital outputs	
Number/binary outputs	2
Functionality/short-circuit strength	Yes
• Response threshold, typ.	10 A
Limitation of inductive shutdown voltage to	L+ (-50 to -65 V)
Lamp load, max.	10 W
Accuracy of pulse duration	+/- (time period x 100 ppm), +/-100 µs with a load <= 50 ohms
minimum pulse duration	100 µs
Controlling a digital input	Yes
Output voltage	
• for signal "1", min.	L+ (-1 V)
Output current	
• for signal "1" rated value	2 A
• for signal "1" permissible range for 0 to 60 °C, min.	7 mA
• for signal "1" permissible range for 0 to 60 °C, max.	2 A
• for signal "0" residual current, max.	0.5 mA
Output delay with resistive load	
• "0" to "1", max.	100 µs
• "1" to "0", max.	200 µs
Switching frequency	
• with resistive load, max.	5 kHz
• with inductive load, max.	2 Hz
• on lamp load, max.	10 Hz
Cable length	
• Cable length, shielded, max.	1 000 m
• Cable length unshielded, max.	600 m
Encoder	
Connectable encoders	
• 2-wire sensor	Yes
- Permissible quiescent current (2-wire sensor), max.	2 mA

SIMATIC ET 200 distributed I/O

ET 200S

Technology modules
2 PULSE pulse generator

Technical specifications (continued)

6ES7 138-4DD01-0AB0	
Interrupts/diagnostics/status information	
Diagnostics indication LED	
• Group error SF (red)	Yes
• Status indicator digital output (green)	Yes
• Status indicator digital input (green)	Yes
Pulse generator	
Number of channels	2; 1 digital input and 1 digital output per channel
Galvanic isolation	
Galvanic isolation digital inputs	
• between the channels	No
• between the channels and the backplane bus	Yes
Galvanic isolation digital outputs	
• between the channels	No
• between the channels and the backplane bus	Yes
Permissible potential difference	
between different circuits	75 VDC / 60 VAC
Isolation	
Isolation checked with	500 V DC
Dimensions	
Width	15 mm
Height	81 mm
Depth	52 mm
Weight	
Weight, approx.	40 g

Ordering data

Pulse generator and timer module
2PULSE

For ET 200S

Accessories

Label sheets DIN A4 (10 pieces)

Each sheet contains 60 labeling strips for peripheral modules and 20 labeling strips for interface modules

- petrol
- red
- yellow
- light beige

Order No.

6ES7 138-4DD01-0AB0

6ES7 193-4BH00-0AA0
6ES7 193-4BD00-0AA0
6ES7 193-4BB00-0AA0
6ES7 193-4BA00-0AA0

SIMATIC ET 200 distributed I/O

ET 200S

Technology modules

1STEP stepper module

Overview



- 1-channel module for ET 200S for controlled positioning of a stepper motor
- Operating modes: absolute and relative positioning, reference point approach, set reference point and speed mode
- Connection of power units with pulse/direction interface by means of 5 V differential signals up to 510 kHz
- External stop with/without ramp via digital input
- Status display and error indication via LEDs:
Errors during positioning and statuses of the digital inputs are indicated by means of LEDs and displayed at the interface to the master
- Isochronous mode

Technical specifications

6ES7 138-4DC01-0AB0	
Supply voltage	
Load voltage L+	
• Rated value (DC)	24 V
Power losses	
Power loss, typ.	1.5 W
Digital inputs	
Number/binary inputs	2
Functions	Reference cams, pulse suppression, external stop, limit switch
Repeat frequency, max.	100 Hz
Input characteristic curve acc. to IEC 61131, Type 2	Yes
Input voltage	
• Rated value, DC	24 V
• for signal "0"	-30 to +5 V (-15% / +20%)
• for signal "1"	11 to 30 V
Input current	
• for signal "0", max. (permissible quiescent current)	2 mA
• for signal "1", typ.	9 mA
Input delay (for rated value of input voltage)	
• for standard inputs	
- at "0" to "1", max.	4 ms
- at "1" to "0", max.	4 ms
Cable length	
• Cable length, shielded, max.	1 000 m
• Cable length unshielded, max.	600 m

6ES7 138-4DC01-0AB0	
Encoder	
Connectable encoders	
• 2-wire sensor	Yes
Interrupts/diagnostics/ status information	
Diagnostics indication LED	
• Description	1 green LED for status indication "Ready for positioning jobs"
• Positioning mode POS (green)	Yes
• Group error SF (red)	Yes
• Status indicator digital input (green)	Yes
Drive technology	
Cable length, max.	100 m; twisted and shielded in pairs
Step-by-step controllers	
Connection for stepper motors	Differential signals for pulses (PULSE, notPULSE) and direction (DIR, notDIR) to RS422
Number of stepper motor channels	1
Dimensions	
Width	15 mm
Height	81 mm
Depth	52 mm
Weight	
Weight, approx.	40 g

Ordering data

1STEP stepper module

for simple positioning tasks with stepper motor axes

Order No.

6ES7 138-4DC01-0AB0

Order No.

Accessories

Label sheets DIN A4 (10 pieces)

Each sheet contains 60 labeling strips for peripheral modules and 20 labeling strips for interface modules

- petrol
- red
- yellow
- light beige

6ES7 193-4BH00-0AA0
6ES7 193-4BD00-0AA0
6ES7 193-4BB00-0AA0
6ES7 193-4BA00-0AA0

Overview



- The positioning module 1 POS U is a single-channel positioning module for ET 200S for positioning of adjusting and operating axes
- For controlled positioning by means of digital outputs according to the rapid traverse/creep speed principle

- With position value recording for
 - Incremental encoders with 5 V differential signals or 24 V signals or for SSI encoders
 - Dosing operation (single evaluation of encoder signal A only)
- Reference point approach, set actual value
- Parameter change during operation
 - Switchover difference
 - Switch-off difference
- Functions
 - Jog: Direct specification of control signals by the master
 - Travel: Absolute or relative
 - Axes: For linear and rotary axes
 - Latch function: Saving the current actual value by setting a digital input

Note

We offer position measuring systems and preassembled connecting cables for counting and positioning functions under the names SIMODRIVE Sensor or Motion Connect 500.

Technical specifications

6ES7 138-4DL00-0AB0	
Supply voltage	
Load voltage L+	
• Rated value (DC)	24 V
• permissible range, lower limit (DC)	20.4 V
• permissible range, upper limit (DC)	28.8 V
• Reverse polarity protection	Yes
Input current	
from load voltage L+ (without load), max.	55 mA
from backplane bus 3.3 V DC, max.	10 mA
Encoder supply	
5 V encoder supply	
• 5 V	No
24 V encoder supply	
• 24 V	Yes
• Short-circuit protection	Yes
• Output current, max.	500 mA
Absolute encoder (SSI) encoder supply	
• Absolute encoder (SSI)	Yes
• Output voltage	L+ (-0.8 V)
• Output current, max.	500 mA
• Short-circuit protection	Yes
Power losses	
Power loss, typ.	2 W
Digital inputs	
Input characteristic curve acc. to IEC 61131, Type 2	Yes
Input voltage	
• Rated value, DC	24 V
• for signal "0"	-30 to +5 V
• for signal "1"	11 to 30 V

6ES7 138-4DL00-0AB0	
Input current	
• for signal "0", max. (permissible quiescent current)	2 mA
• for signal "1", typ.	9 mA
Cable length	
• Cable length unshielded, max.	50 m
Digital outputs	
Functionality/short-circuit strength	Yes
• Response threshold, typ.	0.7 to 1.8 A
Limitation of inductive shutdown voltage to	Yes; L+ (-55 to 60 V)
Lamp load, max.	5 W
Controlling a digital input	Yes
Output voltage	
• Rated value (DC)	24 V
• for signal "0", max.	3 V
• for signal "1", min.	L+ (-1 V)
Output current	
• for signal "1" permissible range for 0 to 60 °C, min.	7 mA
• for signal "1" permissible range for 0 to 60 °C, max.	600 mA
• for signal "0" residual current, max.	0.3 mA
Output delay with resistive load	
• "0" to "1", max.	typically 150 µs
• "1" to "0", max.	typically 150 µs
Switching frequency	
• with resistive load, max.	100 Hz
• with inductive load, max.	2 Hz
• on lamp load, max.	10 Hz
Cable length	
• Cable length, shielded, max.	1 000 m
• Cable length unshielded, max.	600 m

SIMATIC ET 200 distributed I/O

ET 200S

Technology modules

1 POS U positioning module

Technical specifications (continued)

6ES7 138-4DL00-0AB0	
Encoder	
Number of connectable encoders, max.	1
Connectable encoders	
• Incremental encoder (symmetrical)	Yes
• Incremental encoder (asymmetrical)	Yes
• Absolute encoder (SSI)	Yes
• 2-wire sensor	Yes; Type 2
Encoder signals, incremental encoder (symmetrical)	
• Encoder signal 5 V	
- Signal level	to RS-422
- Terminating resistor	330 Ω
- Differential input voltage, min.	1 V
- Input frequency, max.	500 kHz
- Cable length, shielded, max.	50 m
• Encoder signal 24 V	
- Rated value 24 V DC	Yes
- Input voltage for signal "0"	5 V
- Input voltage for signal "1"	30 V
- Input current, for signal "0", max. (permissible quiescent current)	2 mA
- Input current for signal "1", typ.	9 mA
- Input frequency, max.	100 kHz
- Cable length, shielded, max.	50 m
Encoder signals, absolute encoder (SSI)	
• Cable length, shielded, max.	320 m at 125 kHz, 160 m at 250 kHz, 60 m at 500 kHz, 20 m at 1 MHz, 8 m at 2 MHz, twisted in pairs and shielded
• Monoflop time	64 ms
• Updating the encoder value	
- Telegram runtime at 13 bit, min.	7 ms
- Telegram runtime at 25 bit, min.	13 ms
Response times	
Update time of the feedback messages	1 ms
Latch	In the case of incremental encoders: typ. 400 ms; in the case of SSI encoders: typ. 400 ms + age of the encoder value:
Response time at switchover/switchoff time	In the case of incremental encoders: output delay + 30 μs; in the case of SSI encoders: output delay + message frame runtime + 30 ms
Interrupts/diagnostics/status information	
Diagnostics indication LED	
• Actual value falling DN (green)	Yes
• Actual value rising UP (green)	Yes
• Positioning mode POS (green)	Yes
• Group error SF (red)	Yes
• Status indicator digital input (green)	Yes
Galvanic isolation	
between backplane bus and all other circuit components	Yes
between the channels and backplane bus	Yes
Dimensions	
Width	30 mm
Height	81 mm
Depth	52 mm
Weight	
Weight, approx.	65 g

Ordering data

Order No.

1POS U positioning module

Single-channel positioning module for ET 200S for positioning of positioning and operating axes

6ES7 138-4DL00-0AB0

Overview



- 1-channel 32-bit intelligent counter module for universal count tasks and time-based measuring tasks
- For the direct connection of 24 V incremental sensors or initiators
- Comparison function with predefinable comparison values
- Integrated digital output to output the reaction when the comparison value is attained
- Can be plugged into TM-E terminal module with automatic coding
- Module replacement possible during operation and under power (hot swapping)
- Simple parameterization without additional software

Note:

Siemens is now able to offer distance measuring systems and pre-assembled connecting cables for counting and positioning functions in the product ranges SIMODRIVE Sensor and Motion Connect 500.

Technical specifications

6ES7 138-4DA04-0AB0	
Supply voltage	
Load voltage L+	
• Rated value (DC)	24 V
• permissible range, lower limit (DC)	20.4 V
• permissible range, upper limit (DC)	28.8 V
• Reverse polarity protection	Yes
Input current	
from load voltage L+ (without load), max.	42 mA
from backplane bus 3.3 V DC, max.	10 mA
Encoder supply	
24 V encoder supply	
• 24 V	Yes; L+ (-0.8 V)
• Short-circuit protection	Yes
• Output current, max.	500 mA
Power losses	
Power loss, typ.	1 W
Hardware configuration	
Module exchange	
• Hot swapping the IM-DP	Yes
• Module exchange under process voltage	Yes
Digital inputs	
Number/binary inputs	1
Functions	Gate control, synchronization, latch function
Input characteristic curve acc. to IEC 61131, Type 2	Yes
Input voltage	
• Rated value, DC	24 V
• for signal "0"	-30 to +5 V
• for signal "1"	11 to 30 V
Input current	
• for signal "0", max. (permissible quiescent current)	2 mA
• for signal "1", typ.	9 mA
Input delay (for rated value of input voltage)	
• for standard inputs	
- at "0" to "1", max.	2.5 µs; Filter off: 2.5 µs (200 kHz), filter on: 25 µs (20 kHz)
Cable length	
• Cable length, shielded, max.	100 m; Filter 20 kHz: 100 m, filter 200 kHz: 50 m

6ES7 138-4DA04-0AB0	
Digital outputs	
Number/binary outputs	1
Functionality/short-circuit strength	Yes
• Response threshold, typ.	2.6 A to 4 A
Limitation of inductive shutdown voltage to	L+ (-50 to -60 V)
Lamp load, max.	5 W
Controlling a digital input	Yes
Output voltage	
• Rated value (DC)	24 V
• for signal "0", max.	3 V
• for signal "1", min.	L+ (-1 V)
Output current	
• for signal "1" permissible range for 0 to 40 °C, min.	5 mA
• for signal "1" permissible range for 0 to 40 °C, max.	2 000 mA
• for signal "1" permissible range for 0 to 60 °C, min.	5 mA
• for signal "1" permissible range for 0 to 60 °C, max.	500 mA; 1000 mA at 50 °C
• for signal "0" residual current, max.	0.5 mA
Output delay with resistive load	
• "0" to "1", max.	100 µs
Switching frequency	
• with resistive load, max.	100 Hz
• with inductive load, max.	2 Hz
• on lamp load, max.	10 Hz
Cable length	
• Cable length, shielded, max.	1 000 m
• Cable length unshielded, max.	600 m
Encoder	
Number of connectable encoders, max.	1
Connectable encoders	
• Incremental encoder (asymmetrical)	Yes
• 24 V initiator	Yes
• 2-wire sensor	Yes

SIMATIC ET 200 distributed I/O

ET 200S

Technology modules

1 COUNT 24 V/100 kHz counter module

Technical specifications (continued)

6ES7 138-4DA04-0AB0	
Interrupts/diagnostics/status information	
Diagnostic messages	
• Diagnostic functions	Yes
Diagnostics indication LED	
• Group error SF (red)	Yes
• Status indicator digital output (green)	Yes
• Status indicator digital input (green)	Yes
• Status indicator backward counting (green)	Yes
• Status indicator forward counting (green)	Yes
Counter	
Number of counter inputs	1; 32 bits
Minimum pulse width	2.5 µs; Filter off: 2.5 µs (200 kHz), filter on: 25 µs (20 kHz)
Frequency measurement	
Measurement range, min.	0.1 Hz
Measurement range, max.	100 kHz
Cycle duration measurement	
Measuring range, lower limit	10 µs
Measuring range, upper limit	120 s
Speed measurement	
Measurement range, min. (lower limit)	1 1/min
Measurement range, max. (upper limit)	25 000 1/min
Parameter	
Remark	16 byte
Galvanic isolation	
Galvanic isolation digital inputs	
• Galvanic isolation digital inputs	No; only opposite shielding
Galvanic isolation counter	
• between the channels and the backplane bus	Yes
• between the channels and the load voltage L+	No
Dimensions	
Width	15 mm
Height	81 mm
Depth	52 mm
Weight	
Weight, approx.	40 g

Ordering data

Ordering data	Order No.
1 COUNT 24 V/100 kHz counter module	6ES7 138-4DA04-0AB0
For universal counting and measuring tasks with ET 200S	
Accessories	
Label sheets DIN A4 (10 pieces)	
Each sheet contains 60 labeling strips for peripheral modules and 20 labeling strips for interface modules	
• petrol	6ES7 193-4BH00-0AA0
• red	6ES7 193-4BD00-0AA0
• yellow	6ES7 193-4BB00-0AA0
• light beige	6ES7 193-4BA00-0AA0
Shield connection element	
For TM-P and TM-E terminal modules, as fixing for busbars 3 x 10 mm, 5 items	6ES7 193-4GA00-0AA0
Shield clamps	
For connecting braided cable shields to the busbar, 5 items	6ES7 193-4GB00-0AA0
SIMODRIVE sensor incremental encoder	
Externally mounted encoder, optical, incremental with HTL level, operating voltage 10 to 30 V	
• With synchronous flange, universal axial/radial cable outlet with connector	
- 100 pulses/revolution	6FX2 001-4DA10
- 500 pulses/revolution	6FX2 001-4DA50
- 1000 pulses/revolution	6FX2 001-4DB00
- 2500 pulses/revolution	6FX2 001-4DC50
• With synchronous flange, radial flange outlet	
- 100 pulses/revolution	6FX2 001-4FA10
- 500 pulses/revolution	6FX2 001-4FA50
- 1000 pulses/revolution	6FX2 001-4FB00
- 2500 pulses/revolution	6FX2 001-4FC50
• With synchronous flange, axial flange outlet	
- 100 pulses/revolution	6FX2 001-4HA10
- 500 pulses/revolution	6FX2 001-4HA50
- 1000 pulses/revolution	6FX2 001-4HB00
- 2500 pulses/revolution	6FX2 001-4HC50
• With clamping flange, universal axial/radial cable outlet with connector	
- 100 pulses/revolution	6FX2 001-4NA10
- 500 pulses/revolution	6FX2 001-4NA50
- 1000 pulses/revolution	6FX2 001-4NB00
- 2500 pulses/revolution	6FX2 001-4NC50
• With clamping flange, radial flange outlet	
- 100 pulses/revolution	6FX2 001-4QA10
- 500 pulses/revolution	6FX2 001-4QA50
- 1000 pulses/revolution	6FX2 001-4QB00
- 2500 pulses/revolution	6FX2 001-4QC50
• With clamping flange, axial flange outlet	
- 100 pulses/revolution	6FX2 001-4SA10
- 500 pulses/revolution	6FX2 001-4SA50
- 1000 pulses/revolution	6FX2 001-4SB00
- 2500 pulses/revolution	6FX2 001-4SC50
Signal cable	
Preassembled for HTL and TTL encoder, without Sub-D connector, UL/DESINA	6FX5 002-2CA12-....
For length code, see page 5/114	

Overview



- Single-channel, intelligent 32-bit counter module for universal counting and measuring tasks
- For direct connection of 24 V incremental encoders or initiators
- Comparison functions with definable comparison values
- Integrated digital output for output of the response on reaching the comparison value
- Can be plugged onto TM-E terminal modules with automatic coding
- Hot swapping of modules possible
- Simple parameterization without additional software

Notes:

We offer position measuring systems and pre-assembled connecting cables for counting and positioning functions under the names SIMODRIVE Sensor or Motion Connect 500.

SIPLUS extreme products are based on Siemens Industry standard products. The contents listed here were taken from the respective standard products. SIPLUS extreme specific information was added.

SIPLUS counter module 1 Count 24 V/100 kHz

Order No.	6AG1 138-4DA04-2AB0
Order No. based on	6ES7 138-4DA04-0AB0
Ambient temperature range	-25 °C ... +60 °C
Conformal coating	Coating of the printed circuit boards and the electronic components
Technical data	The technical data of the standard product applies except for the ambient conditions.
Ambient conditions	
Relative humidity	100%, condensation/frost permissible. No commissioning if condensation present.
Biologically active substances, compliance with EN 60721-3-3	Class 3B2 mold spores, fungal spores (excluding fauna). The supplied plug covers must remain in place over the unused interfaces during operation!
Chemically active substances, compliance with EN 60721-3-3	Class 3C4 incl. salt spray in accordance with EN60068-2-52 (degree of severity 3). The supplied plug covers must remain in place over the unused interfaces during operation!
Mechanically active substances, compliance with EN 60721-3-3	Class 3S4 incl. sand, dust. The supplied plug covers must remain in place over the unused interfaces during operation!
Air pressure (depending on the highest positive temperature range specified)	1 080 ... 795 hPa (-1 000 ... +2 000 m) see ambient temperature range 795 ... 658 hPa (+2 000 ... +3 500 m) derating 10 K 658 ... 540 hPa (+3 500 ... +5 000 m) derating 20 K

For further technical documentation on SIPLUS, see:
<http://www.siemens.com/siplus-extreme>

Ordering data

**SIPLUS counter module
1 COUNT 24 V/100 kHz**

(extended temperature range and
medial exposure)

For universal counting and
measuring tasks with ET 200S

Order No.

6AG1 138-4DA04-2AB0

Accessories

See SIMATIC counter module
1 COUNT 24 V/100 kHz,
page 9/116

SIMATIC ET 200 distributed I/O

ET 200S

Technology modules

1 COUNT 5 V/500 kHz counter module

Overview



- 1-channel 32-bit intelligent counter module for universal count tasks and time-based measuring tasks
- For direct connection of 5 V incremental encoders (RS 422)
- Comparison function with predefinable comparison values
- 2 integrated digital outputs to output the response upon reaching the comparison value
- Can be plugged into TM-E terminal module with automatic coding
- Module replacement possible during operation and under power (hot swapping)
- Simple parameterization without additional software

Note:

Siemens is now able to offer distance measuring systems and pre-assembled connecting cables for counting and positioning functions in the product ranges SIMODRIVE Sensor and Motion Connect 500.

Technical specifications

6ES7 138-4DE02-0AB0	
Supply voltage	
Load voltage L+	
• Rated value (DC)	24 V
• permissible range, lower limit (DC)	20.4 V
• permissible range, upper limit (DC)	28.8 V
• Reverse polarity protection	Yes
Input current	
from load voltage L+ (without load), max.	45 mA
from backplane bus 3.3 V DC, max.	10 mA
Encoder supply	
24 V encoder supply	
• 24 V	Yes; L+ (-0.8 V)
• Short-circuit protection	Yes
• Output current, max.	500 mA
Power losses	
Power loss, typ.	2 W
Hardware configuration	
Module exchange	
• Hot swapping the IM-DP	Yes
• Module exchange under process voltage	Yes
Digital inputs	
Number/binary inputs	1
Functions	Gate control, synchronization, latch function
Input characteristic curve acc. to IEC 61131, Type 2	Yes
Input voltage	
• Rated value, DC	24 V
• for signal "0"	-30 to +5 V
• for signal "1"	11 to 30 V
Input current	
• for signal "0", max. (permissible quiescent current)	2 mA
• for signal "1", typ.	9 mA
Input delay (for rated value of input voltage)	
• for standard inputs - at "0" to "1", max.	2.5 μs
Cable length	
• Cable length, shielded, max.	50 m

6ES7 138-4DE02-0AB0	
Digital outputs	
Number/binary outputs	2
Functionality/short-circuit strength	Yes
• Response threshold, typ.	2.6 A to 4 A
Limitation of inductive shutdown voltage to	L+ (-50 to -60 V)
Lamp load, max.	10 W
Controlling a digital input	Yes
Output voltage	
• Rated value (DC)	24 V
• for signal "0", max.	3 V
• for signal "1", min.	L+ (-1 V)
Output current	
• for signal "1" rated value	2 A
• for signal "1" permissible range for 0 to 60 °C, min.	5 mA
• for signal "1" permissible range for 0 to 60 °C, max.	2.4 A
• for signal "0" residual current, max.	0.5 mA
Output delay with resistive load	
• "0" to "1", max.	100 μs
Switching frequency	
• with resistive load, max.	100 Hz
• with inductive load, max.	2 Hz
• on lamp load, max.	10 Hz
Cable length	
• Cable length, shielded, max.	1 000 m
• Cable length unshielded, max.	600 m
Encoder	
Number of connectable encoders, max.	1
Connectable encoders	
• Incremental encoder (symmetrical)	Yes
• 2-wire sensor	Yes
Encoder signals, incremental encoder (symmetrical)	
• Trace mark signals	A, notA, B, notB, A and B offset by 90° N, notN
• Zero mark signal	
• Input signal	5 V difference signal (phys. RS 422)
• Input frequency, max.	650 kHz
• Cable length, shielded, max.	50 m; > 500 kHz: 30 m

Technical specifications (continued)

6ES7 138-4DE02-0AB0	
Interrupts/diagnostics/ status information	
Diagnostic messages	
• Diagnostic functions	Yes
Diagnostics indication LED	
• Group error SF (red)	Yes
• Status indicator digital output (green)	Yes
• Status indicator digital input (green)	Yes
• Status indicator backward counting (green)	Yes
• Status indicator forward counting (green)	Yes
• Synchronization SYN (green)	Yes
Counter	
Number of counter inputs	1; 32 bits
Frequency measurement	
Measurement range, min.	0.1 Hz
Measurement range, max.	500 kHz
Cycle duration measurement	
Measuring range, lower limit	10 µs
Measuring range, upper limit	120 s

6ES7 138-4DE02-0AB0	
Speed measurement	
Measurement range, min. (lower limit)	1 1/min
Measurement range, max. (upper limit)	25 000 1/min
Parameter	
Remark	16 byte
Galvanic isolation	
Galvanic isolation digital inputs	
• Galvanic isolation digital inputs	No; only opposite shielding
Galvanic isolation counter	
• between the channels and the backplane bus	Yes
• between the channels and the load voltage L+	No
Dimensions	
Width	30 mm
Height	81 mm
Depth	52 mm
Weight	
Weight, approx.	65 g

SIMATIC ET 200 distributed I/O

ET 200S

Technology modules

1 COUNT 5 V/500 kHz counter module

Ordering data

1 COUNT 5 V/500 kHz counter module

For universal counting and measuring tasks with ET 200S

Accessories

Label sheets DIN A4 (10 pieces)

Each sheet contains 60 labeling strips for peripheral modules and 20 labeling strips for interface modules

- petrol
- red
- yellow
- light beige

Shield connection element

For TM-P and TM-E terminal modules, as fixing for busbars 3 x 10 mm, 5 items

Shield clamps

For connecting braided cable shields to the busbar, 5 items

SIMODRIVE

Incremental shaft encoder

with RS422 (TTL), operating voltage 10 to 30 V

- With synchronous flange, universal axial/radial cable outlet with connector
 - 500 pulses/revolution
 - 1000 pulses/revolution
 - 1024 pulses/revolution
 - 1250 pulses/revolution
 - 1500 pulses/revolution
 - 2000 pulses/revolution
 - 2048 pulses/revolution
 - 2500 pulses/revolution
 - 3600 pulses/revolution
 - 5000 pulses/revolution
- With synchronous flange, radial flange outlet
 - 500 pulses/revolution
 - 1000 pulses/revolution
 - 1024 pulses/revolution
 - 1250 pulses/revolution
 - 1500 pulses/revolution
 - 2000 pulses/revolution
 - 2048 pulses/revolution
 - 2500 pulses/revolution
 - 3600 pulses/revolution
 - 5000 pulses/revolution

Order No.

6ES7 138-4DE02-0AB0

6ES7 193-4BH00-0AA0
6ES7 193-4BD00-0AA0
6ES7 193-4BB00-0AA0
6ES7 193-4BA00-0AA0

6ES7 193-4GA00-0AA0

6ES7 193-4GB00-0AA0

6FX2 001-2DA50
6FX2 001-2DB00
6FX2 001-2DB02
6FX2 001-2DB25
6FX2 001-2DB50
6FX2 001-2DC00
6FX2 001-2DC04
6FX2 001-2DC50
6FX2 001-2DD60
6FX2 001-2DF00

6FX2 001-2FA50
6FX2 001-2FB00
6FX2 001-2FB02
6FX2 001-2FB25
6FX2 001-2FB50
6FX2 001-2FC00
6FX2 001-2FC04
6FX2 001-2FC50
6FX2 001-2FD60
6FX2 001-2FF00

Order No.

6FX2 001-2HA50
6FX2 001-2HB00
6FX2 001-2HB02
6FX2 001-2HB25
6FX2 001-2HB50
6FX2 001-2HC00
6FX2 001-2HC04
6FX2 001-2HC50
6FX2 001-2HD60
6FX2 001-2HF00

6FX2 001-2NA50
6FX2 001-2NB00
6FX2 001-2NB02
6FX2 001-2NB25
6FX2 001-2NB50
6FX2 001-2NC00
6FX2 001-2NC04
6FX2 001-2NC50
6FX2 001-2ND60
6FX2 001-2NF00

6FX2 001-2QA50
6FX2 001-2QB00
6FX2 001-2QB02
6FX2 001-2QB25
6FX2 001-2QB50
6FX2 001-2QC00
6FX2 001-2QC04
6FX2 001-2QC50
6FX2 001-2QD60
6FX2 001-2QF00

6FX2 001-2SA50
6FX2 001-2SB00
6FX2 001-2SB02
6FX2 001-2SB25
6FX2 001-2SB50
6FX2 001-2SC00
6FX2 001-2SC04
6FX2 001-2SC50
6FX2 001-2SD60
6FX2 001-2SF00

- With synchronous flange, axial flange outlet

- 500 pulses/revolution
- 1000 pulses/revolution
- 1024 pulses/revolution
- 1250 pulses/revolution
- 1500 pulses/revolution
- 2000 pulses/revolution
- 2048 pulses/revolution
- 2500 pulses/revolution
- 3600 pulses/revolution
- 5000 pulses/revolution

- With clamping flange, universal axial/radial cable outlet with connector

- 500 pulses/revolution
- 1000 pulses/revolution
- 1024 pulses/revolution
- 1250 pulses/revolution
- 1500 pulses/revolution
- 2000 pulses/revolution
- 2048 pulses/revolution
- 2500 pulses/revolution
- 3600 pulses/revolution
- 5000 pulses/revolution

- With clamping flange, radial flange outlet

- 500 pulses/revolution
- 1000 pulses/revolution
- 1024 pulses/revolution
- 1250 pulses/revolution
- 1500 pulses/revolution
- 2000 pulses/revolution
- 2048 pulses/revolution
- 2500 pulses/revolution
- 3600 pulses/revolution
- 5000 pulses/revolution

- With clamping flange, axial flange outlet

- 500 pulses/revolution
- 1000 pulses/revolution
- 1024 pulses/revolution
- 1250 pulses/revolution
- 1500 pulses/revolution
- 2000 pulses/revolution
- 2048 pulses/revolution
- 2500 pulses/revolution
- 3600 pulses/revolution
- 5000 pulses/revolution

Signal cable

Preassembled for HTL and TTL encoder, without Sub-D connector, UL/DESINA

For length code, see page 5/114

6FX5 002-2CA12-....

Overview



- 1-channel module for serial data communication via point-to-point link
- For message frames max. 224 bytes long
- RS-232C, RS-422, RS-485
- 2 versions
 - ASCII and 3964(R) protocols
 - Modbus and USS protocols
- Configuration via GSD file or STEP 7 (from V5.1)

Technical specifications

	6ES7 138-4DF01-0AB0	6ES7 138-4DF11-0AB0
Supply voltage		
Load voltage L+		
• Rated value (DC)	24 V	24 V
Input current		
from backplane bus 3.3 V DC, max.	10 mA	10 mA
from backplane bus 24 V DC, max.	80 mA; Typ. 20 mA	80 mA
Power losses		
Power loss, typ.	1.2 W	1.2 W
Memory		
Standard blocks	5 100 byte; S_SEND 2700, S_RCV 2400, S_XON 2600, S_RTS 2600, S_V24 2700, S_VSTAT 1800, S_VSET 1800	11 100 byte; Modbus: S_SEND 2700, S_RCV 2400, S_MOVB 6000; USI: S_SEND 2700, S_RCV 2400, S_USST 1900, S_USSR 2600, S_USSI 1500
Interfaces		
Number of interfaces	1	1
RS 422/RS485	Yes; RS-422 signals: 5 (TxD(A), RxD(A), TxD(B), RxD(B), PE); RS-485 signals: 3 (R/T(A), R/T(B), PE)	Yes; RS-422 signals: 5 (TxD(A), RxD(A), TxD(B), RxD(B), PE); RS-485 signals: 3 (R/T(A), R/T(B), PE)
RS 232, cable length, shielded, max.	15 m	15 m
RS 422/485, cable length, shielded, max.	1 200 m	1 200 m
Point-to-point		
• RS 232C	Yes; RS 232C signals: 8 (TxD, RxD, RTS, CTS, DTR, DSR, DCD, PE)	Yes; RS 232C signals: 8 (TxD, RxD, RTS, CTS, DTR, DSR, DCD, PE)
• Integrated protocol driver		
- 3964 (R)	Yes	
- ASCII	Yes	
- MODBUS		Yes
- Transmission speed, Modbus protocol, max.		115.2 kbit/s; half duplex: 110, 300, 600, 1200, 2400, 4800, 9600, 19,200, 38,400, 57,600, 76,800, 115,200 bit/s
- USS		Yes
- Transmission speed, USS protocol, max.		115.2 kbit/s; half duplex: 110, 300, 600, 1200, 2400, 4800, 9600, 19,200, 38,400, 57,600, 76,800, 115,200 bit/s
• Telegram length, max.		
- 3964 (R)	224 byte	
- ASCII	224 byte	
• Transmission speed, RS 422/485		
- with 3964 (R) protocol, max.	115.2 kbit/s; half duplex: 110, 300, 600, 1200, 2400, 4800, 9600, 19,200, 38,400, 57,600, 76,800, 115,200 bit/s	
- with ASCII protocol, max.	115.2 kbit/s; Full duplex: 110, 300, 600, 1200, 2400, 4800, 9600, 19,200, 38,400, 57,600, 76,800, 115,200 bit/s	

SIMATIC ET 200 distributed I/O

ET 200S

Technology modules

1SI interface module

Technical specifications (continued)

	6ES7 138-4DF01-0AB0	6ES7 138-4DF11-0AB0
Point-to-point		
• Transmission speed, RS232		
- with 3964 (R) protocol, max.	115.2 kbit/s; half duplex: 110, 300, 600, 1200, 2400, 4800, 9600, 19,200, 38,400, 57,600, 76,800, 115,200 bit/s	
- with ASCII protocol, max.	115.2 kbit/s; Full duplex: 110, 300, 600, 1200, 2400, 4800, 9600, 19,200, 38,400, 57,600, 76,800, 115,200 bit/s	
• Character frame (adjustable)		
- Bits per character	7 or 8	8
- Number of start/stop bits	1 or 2	1 or 2 (USS only 1)
- Bits per character frame	10	10 or 11 (USS only 11 bits)
- Parity	none, odd, even, any	none, odd, even (USI even only)
• Number of bytes per PLC sampling cycle		
- Data quantity per PLC sampling cycle, receiving	32 byte; with IM151-1 Standard as of 6ES7 151-1AA04-0AB0; with IM151-1 High Feature as of 6ES7 151-1BA01-0AB0; otherwise 8 bytes	32 byte; with IM151-1 Standard as of 6ES7 151-1AA04-0AB0; with IM151-1 High Feature as of 6ES7 151-1BA01-0AB0; otherwise 8 bytes
- Data quantity per PLC sampling cycle, transmitting	32 byte; with IM151-1 Standard as of 6ES7 151-1AA04-0AB0; with IM151-1 High Feature as of 6ES7 151-1BA01-0AB0; otherwise 8 bytes	32 byte; with IM151-1 Standard as of 6ES7 151-1AA04-0AB0; with IM151-1 High Feature as of 6ES7 151-1BA01-0AB0; otherwise 8 bytes
Interrupts/diagnostics/ status information		
Diagnostics indication LED		
• Receive RxD (green)	Yes	Yes
• Transmit TxD (green)	Yes	Yes
• Group error SF (red)	Yes	Yes
Galvanic isolation		
Electrical isolation interface		
• between 422/485 and internal power supply	Yes	Yes
• between RS 232 and internal power supply	Yes	Yes
Ambient conditions		
Operating temperature		
• Min.	0 °C	0 °C
• max.	60 °C	60 °C
Storage/transport temperature		
• Min.	-40 °C	-40 °C
• max.	70 °C	70 °C
Dimensions		
Width	15 mm	15 mm
Height	81 mm	81 mm
Depth	52 mm	52 mm
Weight		
Weight, approx.	50 g	50 g

Ordering data

1 SI interface module

- ASCII and 3964(R) protocols
- Modbus and USS protocols

Order No.

6ES7 138-4DF01-0AB0
6ES7 138-4DF11-0AB0

Order No.

Accessories

TM-E15S 26-A1 terminal module

Ordering unit 5 items

6ES7 193-4CA40-0AA0

TM-E15S 26-A1 terminal module

Ordering unit 5 items

6ES7 193-4CA50-0AA0

TM-E15N24-A1 terminal module

Ordering unit 5 items

6ES7 193-4CA80-0AA0

TM-E15S24-01 terminal module

Ordering unit 5 items

6ES7 193-4CB20-0AA0

TM-E15C24-01 terminal module

Ordering unit 5 items

6ES7 193-4CB30-0AA0

TM-E15N24-01 terminal module

Ordering unit 5 items

6ES7 193-4CB70-0AA0

Overview



- 1-channel module for serial data communication via point-to-point link
- For message frames max. 200 bytes long
- RS-232C, RS-422, RS-485
- 2 versions
 - ASCII and 3964 (R) protocols
 - Modbus and USS protocols
- Configuration via GSD file or STEP 7 (from V5.1)

Note:

SIPLUS extreme products are based on Siemens Industry standard products. The contents listed here were taken from the respective standard products. SIPLUS extreme specific information was added.

SIPLUS interface module 1SI		
Order No.	6AG1 138-4DF01-7AB0	6AG1 138-4DF11-7AB0
Order No. based on	6ES7 138-4DF01-0AB0	6ES7 138-4DF11-0AB0
Ambient temperature range	-25 °C ... +70 °C	
Conformal coating	Coating of the printed circuit boards and the electronic components	
Technical data	The technical data of the standard product applies except for the ambient conditions.	
Ambient conditions		
Relative humidity	100%, condensation/frost permissible. No commissioning if condensation present.	
Biologically active substances, compliance with EN 60721-3-3	Class 3B2 mold and fungal spores (excluding fauna). The supplied plug covers must remain in place over the unused interfaces during operation!	
Chemically active substances, compliance with EN 60721-3-3	Class 3C4 incl. salt spray in accordance with EN60068-2-52 (degree of severity 3). The supplied plug covers must remain in place over the unused interfaces during operation!	
Mechanically active substances, compliance with EN 60721-3-3	Class 3S4 incl. sand, dust. The supplied plug covers must remain in place over the unused interfaces during operation!	
Air pressure (depending on the highest positive temperature range specified)	1,080...795 hPa (-1,000 ... +2,000 m) See ambient temperature range 795...658 hPa (+2,000 ... +3,500 m) Derating 10 K 658...540 hPa (+3 500 ... +5 000m) Derating 20K	

For technical documentation on SIPLUS, see:
<http://www.siemens.com/siplus-extreme>

Ordering data

Ordering data	Order No.
1 SI interface module (extended temperature range and medial exposure)	
<ul style="list-style-type: none"> • ASCII and 3964(R) protocols • Modbus and USS protocols 	6AG1 138-4DF11-7AB0 6AG1 138-4DF01-7AB0
Accessories	See SIMATIC 1 SI interface module, page 9/122

SIMATIC ET 200 distributed I/O

ET 200S

Technology modules
SIWAREX CS

Overview



SIWAREX CS is a versatile weighing module for all simple weighing and force measuring tasks. The compact module is easy to install in all SIMATIC automation systems. Data can be accessed directly in the SIMATIC.

Technical specifications

SIWAREX CS	
Integration in automation systems	
S7-400, S7-300, C7	Through ET 200S
IM151-7 CPU	Through backplane bus
Automation systems from other manufacturers (possible with limitations)	Through ET 200S
Communication interfaces	
	SIMATIC S7 (ET 200S backplane bus), RS 232, TTY
Connection of remote displays (through TTY serial interface)	
	Display for weight value
Adjustment of scales settings	
	Using SIMATIC S7/C7 IM151-7 CPU or SIWATOOL CS PC parameterization software (RS 232)
Measuring accuracy	
Error limit to DIN 1319-1 of full-scale value at 20 °C ± 10 K	0.05 %
Internal resolution	65535
Data format of weight values	2 byte (fixed-point)
Number of measurements/second	
	50
Digital filter	
	0.05 ... 5 Hz (in 7 steps), mean-value filter
Weighing functions	
Weight values	Gross, net
Limit values	2 (min./max.)
Zero setting function	Per command
Tare function	Per command
Tare specification	Per command
Load cells	
	Strain gages in 4-wire or 6-wire system
Load cell powering	
Supply voltage U_s (rated value)	6 V DC typical
Max. supply current	≤ 68 mA
Permissible load impedance	
• R_{Lmin}	> 87 Ω
• R_{Lmax}	< 4010 Ω
With SIWAREX IS Ex interface:	
• R_{Lmin}	> 87 Ω
• R_{Lmax}	< 4010 Ω

SIWAREX CS	
Load cell characteristic	1 mV/V ... 4 mV/V
Permissible range of measuring signal (at greatest set characteristic value)	-2.4 ... +26.4 mV
Max. distance of load cells	1 000 m
Intrinsically-safe load cell powering	Optional (SIWAREX IS Ex interface)
External load cell powering	Possible up to 24 V
Connection to load cells in Ex zone 1	Optionally via SIWAREX IS Ex interface
Ex approvals zone 2 and safety	ATEX 95, FM, cUL _{US} Haz. Loc.
Supply voltage 24 V DC	
Rated voltage	24 V DC
Max. current consumption	150 mA
IP degree of protection to EN 60529; IEC 60529	IP20
Climatic requirements	
T_{min} (IND) to T_{max} (IND) (operating temperature)	
Vertical installation	-10 ... +60 °C
Horizontal installation	-10 ... +40 °C
EMC requirements according to	EN 61326, EN 45501 NAMUR NE21, Part 1
Dimensions	80 x 125 x 130 mm

Ordering data	Order No.	Order No.
SIWAREX CS Weighing electronics for scales in SIMATIC ET 200S	7MH4910-0AA01	
SIWAREX CS Manual available in a range of languages Free download on the Internet at: www.siemens.com/weighing-technology		
SIWAREX CS "Getting started" Sample software shows beginners how to program the scales in STEP 7. Free download on the Internet at: www.siemens.com/weighing-technology		
Configuration package SIWAREX CS on CD-ROM for SIMATIC S7, version V5.4 or higher • Software for SIWATOOL CS scale adjustment (in a range of languages) • Manuals available on CD (in a range of languages) • SIWAREX CS "Getting started"	7MH4910-0AK01	
SIWATOOL cable from SIWAREX U/CS with serial PC interface, for 9-pin PC interfaces (RS 232), 3 m long	7MH4607-8CA	
Installation material (mandatory)		
Terminal module TM-E 30 mm wide (required for each SIWAREX module)	6ES7193-4CG20-0AA0 or compatible	
Shield contact element Contents 5 items, sufficient for 5 cables	6ES7193-4GA00-0AA0	
Shield connection terminal Contents: 5 items, sufficient for 5 cables Note: one shield connection terminal is required each for the • scales connection and • TTY interface or • RS 232 interface	6ES7193-4GB00-0AA0	
N busbar, galvanized 3 x 10 mm, 1.0 m long	8WA2842	
Feeder terminal for N busbar	8WA2868	
Remote displays (option) The digital remote displays can be connected directly to the SIWAREX CS through the TTY interface. <u>The following remote display can be used:</u> S102 Siebert Industrieelektronik GmbH P.O. Box 1180 D-66565 Eppelborn Tel.: 06806/980-0 Fax: 06806/980-999 Internet: http://www.siebert.de Detailed information available from manufacturer.		
Accessories		
SIWAREX JB junction box, aluminium housing for connecting up to 4 load cells in parallel, and for connecting several junction boxes		7MH4710-1BA
SIWAREX JB junction box, stainless steel housing for connecting up to 4 load cells in parallel		7MH4710-1EA
Ex interface, type SIWAREX Pi With UL and FM approvals, but without ATEX approval for intrinsically-safe connection of load cells, suitable for the SIWAREX U, CS, MS, FTA and FTC weighing modules. Not approved for use in the EU.		7MH4710-5AA
Manual for Ex interface type SIWAREX Pi		C71000-T5974-C29
Ex interface, type SIWAREX IS With ATEX approval, but without UL and FM approvals for intrinsically-safe connection of load cells, including manual, suitable for the SIWAREX U, CS, MS, FTA, FTC and CF weighing modules. Approved for use in the EU. • With short-circuit current < 199 mA DC • With short-circuit current < 137 mA DC		7MH4710-5BA 7MH4710-5CA
Cable (optional)		
Cable Li2Y 1 x 2 x 0.75 ST + 2 x (2 x 0.34 ST) - CY, orange sheath to connect SIWAREX U, CS, MS, FTA, FTC and CF to the junction box (JB), extension box (EB) or Ex interface (Ex-I) or between two JB's, for fixed laying, occasional bending permitted, 10.8 mm outer diameter, for ambient temperature -40 ... +80 °C		7MH4702-8AG
Cable Li2Y 1 x 2 x 0.75 ST + 2 x (2 x 0.34 ST) - CY, blue sheath to connect the junction box (JB) or extension box (EB) in a potentially explosive atmosphere to the Ex interface (Ex-I), for fixed laying, occasional bending permitted, blue PVC insulating sheath, approx. 10.8 mm outer diameter, for ambient temperature -40 ... +80 °C		7MH4702-8AF
Cable LiYCY 4 x 2 x 0.25 mm² for TTY (connect 2 pairs of conductors in parallel), for connection of a remote display		7MH4407-8BD0

SIMATIC ET 200 distributed I/O

ET 200S

Technology modules
SIWAREX CF

Overview



SIWAREX CF is a transmitter for connecting strain-gauge sensors for tasks such as measuring force and torque. The compact module is easy to install in all SIMATIC automation systems. Complete data access to the current measured values is then possible via the SIMATIC.

Technical specifications

SIWAREX CF	
Integration in automation systems	
S7-400, S7-300, C7	Through ET 200S
Automation systems from other vendors	Possible through ET 200S with IM 151-1
Communication interfaces	SIMATIC S7 (ET 200S backplane bus), 8 bytes, I/O area
Module parameterization	Not required (module is pre-parameterized)
Measuring properties	
Error limit to DIN 1319-1 of full-scale value at 20 °C ± 10 K	≤ 0.15 %
Signal resolution	14 bits plus 1 bit sign
Number of measurements/second	50
Low-pass filter	Without or 2 Hz
Sensors	In accordance with the principle of expansion measurement (full bridge) 4-wire connection
Sensor feed	
Supply voltage, short-circuit-proof	6 V DC ± 5 %
Permissible sensor resistance	
• R_{Lmin}	> 250 Ω
• R_{Lmax}	< 4010 Ω

SIWAREX CF	
Permissible sensor cell coefficient	Up to 4 mV/V
Permissible range of the measuring signal	-25.2 ... +25.2 mV
Power Supply	
• Rated voltage	24 V DC
• Max. current consumption	150 mA
Current consumption from backplane bus	Typ. 10 mA
Connection to sensors in Ex zone 1	Optionally via SIWAREX IS Ex interface
Ex approval zone 2 and safety	ATEX 95, cUL _{US} Haz. Loc.
IP degree of protection to EN 60529; IEC 60529	IP20
Climatic requirements T_{min} (IND) to T_{max} (IND) (operating temperature)	
Vertical installation	0 ... +60 °C
Horizontal installation	0 ... +40 °C
EMC requirements according to	NAMUR NE21, Part 1 89/386/EEC
Dimensions	30 x 80 x 50 mm

Ordering data	Order No.	Order No.
SIWAREX CF Weighing module for strain-gauge sensors in SIMATIC ET 200S (SIWAREX CF configuring package not required)	7MH4920-0AA01	
SIWAREX CF manual • German, English Free download on the Internet at: www.siemens.com/weighing-technology		
SIWAREX CF "Getting started" Sample software for easy acquaintance with programming in STEP 7. Free download on the Internet at: www.siemens.com/weighing-technology		
Installation material (mandatory)		
Terminal module TM-E 30 mm wide (required for each SIWAREX module)	6ES7193-4CG20-0AA0 or compatible	
Shield contact element Contents 5 items, sufficient for 5 cables	6ES7193-4GA00-0AA0	
Shield connection terminal Contents: 5 items, sufficient for 5 cables One shield terminal element is required per sensor cable	6ES7193-4GB00-0AA0	
N busbar, galvanized 3 x 10 mm, 1.5 m long	8WA2842	
Feeder terminal for N busbar	8WA2868	
		Accessories
		SIWAREX EB extension box for extending sensor cables
		SIWAREX IS Ex interface With ATEX approval, but without UL and FM approvals , for intrinsically-safe connection of load cells, including Manual, suitable for the SIWAREX U, CS, MS, FTA and FTC weighing modules. Approved for use in the EU. <ul style="list-style-type: none"> • With short-circuit current < 199 mA DC • With short-circuit current < 137 mA DC
		Cable (optional)
		Cable Li2Y 1 x 2 x 0.75 ST + 2 x (2 x 0.34 ST) - CY, orange sheath to connect SIWAREX U, CS, MS, FTA, FTC and CF to the junction box (JB), extension box (EB) or Ex interface (Ex-I) or between two JBs, for fixed laying, occasional bending permitted, 10.8 mm outer diameter, for ambient temperature -40 ... +80 °C
		7MH4710-2AA 7MH4710-5BA 7MH4710-5CA 7MH4702-8AG

¹⁾ Observe project planning help for selecting the suitable TM-E and TM-P

SIMATIC ET 200 distributed I/O

ET 200S

I/O modules – Terminal modules
for power modules and electronic modules

Overview



- Mechanical modules as receptacles for the electronic modules
- For setting up permanent wiring via build-as-you-go voltage buses
- Keyed connection technology to ensure an enhanced vibration resistance of up to 5 g
- Different variants for accepting power modules and electronic modules
- Replaceable terminal box (even within the station network)
- Automatic coding of the electronic modules
- Build-as-you-go shielding of the backplane bus for high data security
- Color coding facility for the terminals and for identifying the slot numbers
- Alternatively available with screw-type or spring-loaded terminals as well as with no-strip fast connection system "FastConnect" for up to 60 % quicker process wiring

Ordering data

TM-P terminal modules for PM-E power modules

TM-P15S23-A1

2 × 3 terminals, terminal access to AUX1 bus, AUX1 interconnected to the left, screw-type terminals

Ordering unit 1 item

6ES7 193-4CC20-0AA0

Ordering unit 5 items

6ES7 193-4CC20-1AA0

TM-P15C23-A1

2 × 3 terminals, terminal access to AUX1 bus, AUX1 interconnected to the left, spring-loaded terminals

Ordering unit 1 item

6ES7 193-4CC30-0AA0

Ordering unit 5 items

6ES7 193-4CC30-1AA0

TM-P15N23-A1

Ordering unit 1 item
2 × 3 terminals, terminal access to AUX1 bus, AUX1 interconnected to the left, FastConnect

6ES7 193-4CC70-0AA0

TM-P15S23-A0

2 × 3 terminals, terminal access to AUX1 bus, AUX1 interrupted to the left, screw-type terminals

Ordering unit 1 item

6ES7 193-4CD20-0AA0

Ordering unit 5 items

6ES7 193-4CD20-1AA0

TM-P15C23-A0

2 × 3 terminals, terminal access to AUX1 bus, AUX1 interrupted to the left, spring-loaded terminals

Ordering unit 1 item

6ES7 193-4CD30-0AA0

Ordering unit 5 items

6ES7 193-4CD30-1AA0

TM-P15N23-A0

Ordering unit 1 item
2 × 3 terminals, terminal access to AUX1 bus, AUX1 interrupted to the left, FastConnect

6ES7 193-4CD70-0AA0

TM-P15S22-01

2 × 2 terminals, no terminal access to AUX1 bus, AUX1 interconnected to the left, screw-type terminals

Ordering unit 1 item

6ES7 193-4CE00-0AA0

Ordering unit 5 items

6ES7 193-4CE00-1AA0

Order No.

TM-P15C22-01

2 × 2 terminals, no terminal access to AUX1 bus, AUX1 interconnected to the left, spring-loaded terminals

Ordering unit 1 item

6ES7 193-4CE10-0AA0

Ordering unit 5 items

6ES7 193-4CE10-1AA0

TM-P15N22-01

Ordering unit 1 item
2 × 2 terminals, terminal access to AUX1 bus, AUX1 interconnected to the left, FastConnect

6ES7 193-4CE60-0AA0

TM-P30S44-A0

Ordering unit 1 item
7 × 2 terminals, terminal access to AUX1 bus, AUX1 interrupted to the left, screw-type terminals for PM-E F PROFIsafe

6ES7 193-4CK20-0AA0

TM-P30C44-A0

Ordering unit 1 item
7 × 2 terminals, terminal access to AUX1 bus, AUX1 interrupted to the left, spring-loaded terminals for PM-E F PROFIsafe

6ES7 193-4CK30-0AA0

Terminal module TM-E for electronic modules ¹⁾

TM-E15S24-A1

Ordering unit 5 item
2 × 4 terminals, terminal access to AUX1 bus, AUX1 interconnected to the left, screw-type terminals

6ES7 193-4CA20-0AA0

TM-E15C24-A1

Ordering unit 5 item
2 × 4 terminals, terminal access to AUX1 bus, AUX1 interconnected to the left, spring-loaded terminals

6ES7 193-4CA30-0AA0

TM-E15S24-01

Ordering unit 5 item
2 × 4 terminals, terminal access to AUX1 bus, AUX1 interconnected to the left, screw-type terminals

6ES7 193-4CB20-0AA0

¹⁾ Observe project planning help for selecting the suitable TM-E and TM-P

Ordering data	Order No.	Order No.
Terminal module TM-E for electronic modules ¹⁾ (continued)		
TM-E15C24-01 Ordering unit 5 item 2 x 4 terminals, terminal access to AUX1 bus, AUX1 interconnected to the left, spring-loaded terminals	6ES7 193-4CB30-0AA0	TM-E30C46-A1 Ordering unit 1 item 4 x 6 terminals, terminal access to AUX1 bus, AUX1 interconnected to the left, spring-loaded terminals
TM-E15S23-01 Ordering unit 5 item 2 x 3 terminals, terminal access to AUX1 bus, AUX1 interconnected to the left, screw-type terminals	6ES7 193-4CB00-0AA0	TM-E15S24-AT Ordering unit 1 piece for internal temperature compensation with 2 AI TC High Feature, screw-type terminal
TM-E15C23-01 Ordering unit 5 item 2 x 3 terminals, terminal access to AUX1 bus, AUX1 interconnected to the left, spring-loaded terminals	6ES7 193-4CB10-0AA0	TM-E15C24-AT Ordering unit 1 piece for internal temperature compensation with 2 AI TC High Feature, spring-loaded terminals
TM-E15N23-01 Ordering unit 5 item 2 x 3 terminals, terminal access to AUX1 bus, AUX1 interconnected to the left, FastConnect	6ES7 193-4CB60-0AA0	Accessories for shield connection
TM-E15N24-01 Ordering unit 5 item 2 x 4 terminals, terminal access to AUX1 bus, AUX1 interconnected to the left, FastConnect	6ES7 193-4CB70-0AA0	Shield connection element Ordering unit 5 pieces For plugging into TM-E and TM-P
TM-E15S26-A1 Ordering unit 5 item 2 x 6 terminals, terminal access to AUX1 bus, AUX1 interconnected to the left, screw-type terminals	6ES7 193-4CA40-0AA0	Shield clamps Ordering unit 5 pieces For busbar 3 x 10 mm
TM-E15C26-A1 Ordering unit 5 item 2 x 6 terminals, terminal access to AUX1 bus, AUX1 interconnected to the left, spring-loaded terminals	6ES7 193-4CA50-0AA0	Grounding terminal Ordering unit 1 item for cable cross-sections up to 25 mm ²
TM-E15N24-A1 Ordering unit 5 item 2 x 4 terminals, terminal access to AUX1 bus, AUX1 interconnected to the left, FastConnect	6ES7 193-4CA70-0AA0	3 x 10 mm busbars Ordering unit 1 item
TM-E15N26-A1 Ordering unit 5 item 2 x 6 terminals, terminal access to AUX1 bus, AUX1 interconnected to the left, FastConnect	6ES7 193-4CA80-0AA0	Accessories for coding
TM-E30S44-01 Ordering unit 1 item 4 x 4 terminals, no terminal access to AUX1 bus, AUX1 interconnected to the left, screw-type terminals	6ES7 193-4CG20-0AA0	Color coding plates Ordering unit 200 pieces for TM-P, TM-E • white • yellow • yellow/green • red • blue • brown • turquoise
TM-E30C44-01 Ordering unit 1 item 4 x 4 terminals, no terminal access to AUX1 bus, AUX1 interconnected to the left, spring-loaded terminals	6ES7 193-4CG30-0AA0	Labels, inscribed Ordering unit 1 set 200 items for slot numbering (1 to 20) 10 x 200 items for slot numbering (1 to 40) 5 x 200 items for slot numbering (1 to 64) 1 x, (1 to 68) 2 x
TM-E30S46-A1 Ordering unit 1 item 4 x 6 terminals, terminal access to AUX1 bus, AUX1 interconnected to the left, screw-type terminals	6ES7 193-4CF40-0AA0	Labels, blank 200 items for slot numbering

¹⁾ Observe project planning help for selecting the suitable TM-E and TM-P

SIMATIC ET 200 distributed I/O

ET 200S

I/O modules SIPLUS – Terminal modules for power and electronic modules

Overview



- Mechanical modules as receptacles for the electronic modules
- For setting up permanent wiring via build-as-you-go voltage buses
- Positive-fit connection technology to ensure enhanced vibration resistance of up to 5 g
- Different versions as receptacles for power modules and electronic modules
- Replaceable terminal box (even within the station network)
- Automatic coding of the electronic modules
- Build-as-you-go shielding of the backplane bus for high data security
- Color coding facility for the terminals and for identifying the slot numbers
- Alternatively available with screw-type or spring-loaded terminals as well as with no-strip fast connection system "FastConnect" for up to 60% quicker process wiring

Note:

SIPLUS extreme products are based on Siemens Industry standard products. The contents listed here were taken from the respective standard products. SIPLUS extreme-specific information was added.

SIPLUS DP TM-P12S23-A0	
Order No.	6AG1 193-4CD20-2AA0
Order No. based on	6ES7 193-4CD20-0AA0
Ambient temperature range	-25 ... +60 °C
Ambient conditions	Suitable for exceptional medial exposure (e.g. in sulfur chloride atmosphere).
Technical data	The technical data are identical with those of the based-on modules.

SIPLUS DP TM-P15C23-A1	
Order No.	6AG1 193-4CD30-2AA0
Order No. based on	6ES7 193-4CD30-0AA0
Ambient temperature range	-25 ... +60 °C
Ambient conditions	Suitable for exceptional medial exposure (e.g. in sulfur chloride atmosphere).
Technical data	The technical data are identical with those of the based-on modules.

SIPLUS DP TM-P15C22-01	
Order No.	6AG1 193-4CE10-2AA0
Order No. based on	6ES7 193-4CE10-0AA0
Ambient temperature range	-40 ... +70 °C
Ambient conditions	Suitable for exceptional medial exposure (e.g. in sulfur chloride atmosphere).
Technical data	The technical data are identical with those of the based-on modules.

SIPLUS DP TM-E15C23-01	
Order No.	6AG1 193-4CB10-7AA0
Order No. based on	6ES7 193-4CB10-0AA0
Ambient temperature range	0 ... +70 °C
Ambient conditions	Suitable for exceptional medial exposure (e.g. in sulfur chloride atmosphere).
Technical data	The technical data are identical with those of the based-on modules.

SIPLUS DP TM-E15N24-01	
Order No.	6AG1 193-4CB70-7AA0
Order No. based on	6ES7 193-4CB70-0AA0
Ambient temperature range	-40 ... +70 °C
Ambient conditions	Suitable for exceptional medial exposure (e.g. in sulfur chloride atmosphere).
Technical data	The technical data are identical with those of the based-on modules.

SIPLUS DP TM-E15C24-A1	
Order No.	6AG1 193-4CA30-2AA0
Order No. based on	6ES7 193-4CA30-0AA0
Ambient temperature range	-25 ... +60 °C
Ambient conditions	Suitable for exceptional medial exposure (e.g. in sulfur chloride atmosphere).
Technical data	The technical data are identical with those of the based-on modules.

SIPLUS DP TM-E15C24-A1	
Order No.	6AG1 193-4CB30-2AA0
Order No. based on	6ES7 193-4CB30-0AA0
Ambient temperature range	-25 ... +60 °C
Ambient conditions	Suitable for exceptional medial exposure (e.g. in sulfur chloride atmosphere).
Technical data	The technical data are identical with those of the based-on modules.

SIPLUS DP TM-E15S26-A1	
Order No.	6AG1 193-4CA40-2AA0
Order No. based on	6ES7 193-4CA40-0AA0
Ambient temperature range	-25 ... +60 °C
Ambient conditions	Suitable for exceptional medial exposure (e.g. in sulfur chloride atmosphere).
Technical data	The technical data are identical with those of the based-on modules.

Overview (continued)

SIPLUS DP TM-E15C26-A1	
Order No.	6AG1 193-4CA50-2AA0
Order No. based on	6ES7 193-4CA50-0AA0
Ambient temperature range	-25 ... +60 °C
Ambient conditions	Suitable for exceptional medial exposure (e.g. in sulfur chloride atmosphere).
Technical data	The technical data are identical with those of the based-on modules.
SIPLUS DP TM-E30C44-01	
Order No.	6AG1 193-4CG30-2AA0
Order No. based on	6ES7 193-4CG30-0AA0
Ambient temperature range	-25 ... +60 °C
Ambient conditions	Suitable for exceptional medial exposure (e.g. in sulfur chloride atmosphere).
Technical data	The technical data are identical with those of the based-on modules.
SIPLUS DP TM-E30C46-A1	
Order No.	6AG1 193-4CF50-7AA0
Order No. based on	6ES7 193-4CF50-0AA0
Ambient temperature range	-40 ... +70 °C
Ambient conditions	Suitable for exceptional medial exposure (e.g. in sulfur chloride atmosphere).
Technical data	The technical data are identical with those of the based-on modules.
SIPLUS DP TM-E15C24-AT	
Order No.	6AG1 193-4CL30-7AA0
Order No. based on	6ES7 193-4CL30-0AA0
Ambient temperature range	0 ... +70 °C
Ambient conditions	Suitable for exceptional medial exposure (e.g. in sulfur chloride atmosphere).
Technical data	The technical data are identical with those of the based-on modules.

Ambient conditions

Relative humidity	5 ... 100 % Condensation permissible
Biologically active substances	Conformity with EN 60721-3-3, Class 3B2 mold and fungal spores (except fauna)
Chemically active substances	Conformity with EN 60721-3-3, Class 3C4 incl. salt mist and ISA-S71.04 severity level G1; G2; G3; GX ¹⁾²⁾
Mechanically active substances	Conformity with EN 60721-3-3, Class 3S4 including conductive sand, dust ²⁾
Air pressure (depending on the highest positive temperature range specified)	1080 ... 795 hPa (-1000 ... +2000 m) see ambient temperature range 795 ... 658 hPa (+2000 ... +3500 m) derating 10 K 658 ... 540 hPa (+3500 ... +5000 m) derating 20 K

¹⁾ ISA-S71.04 severity level GX: Long-term load: SO₂ < 4.8 ppm; H₂S < 9.9 ppm; Cl < 0.2 ppm; HCl < 0.66 ppm; HF < 0.12 ppm; NH < 49 ppm; O₃ < 0.1 ppm; NOX < 5.2 ppm
Limit value (max. 30 min/d): SO₂ < 17.8 ppm; H₂S < 49.7 ppm; Cl < 1.0 ppm; HCl < 3.3 ppm; HF < 2.4 ppm; NH < 247 ppm; O₃ < 1.0 ppm; NOX < 10.4 ppm

²⁾ The supplied plug covers must remain in place over the unused interface when operated in atmospheres containing corrosive gases!

For further technical documentation on SIPLUS, see:
<http://www.siemens.com/siplus-extreme>

SIMATIC ET 200 distributed I/O

ET 200S

I/O modules SIPLUS – Terminal modules for power and electronic modules

Ordering data	Order No.	Ordering data	Order No.
TM-P terminal modules for PM-E power modules (extended temperature range and medial exposure) SIPLUS ET 200S TM-P15C23-A0 Ordering unit: 1 unit 2 x 3 terminals, terminal access to AUX1 bus, AUX1 interrupted to the left, screw connection	6AG1 193-4CD20-2AA0	SIPLUS ET 200S TM-E30C44-01 Ordering unit: 1 unit 4 x 4 terminals, no terminal access to AUX1 bus, AUX1 interconnected to the left, spring-loaded terminals	6AG1 193-4CG30-2AA0
SIPLUS ET 200S TM-P15C23-A0 Ordering unit: 1 unit 2 x 3 terminals, terminal access to AUX1 bus, AUX1 interrupted to the left, spring-loaded terminals	6AG1 193-4CD30-2AA0	SIPLUS ET 200S TM-E30C46-A1 Ordering unit: 1 units 4 x 6 terminals, terminal access to AUX1 bus, AUX1 interconnected to the left, spring-loaded terminals	6AG1 193-4CF50-7AA0
SIPLUS ET 200S TM-P15C22-01 Ordering unit: 1 unit 2 x 2 terminals, no terminal access to AUX1 bus, AUX1 interconnected to the left, spring-loaded terminals	6AG1 193-4CE10-2AA0	SIPLUS ET 200S TM-E15C24-AT Ordering unit: 1 unit For internal temperature compensation with 2 AI TC High Feature, spring-loaded terminals	6AG1 193-4CL30-7AA0
TM-E terminal modules for electronic modules (extended temperature range and medial exposure) SIPLUS ET 200S TM-E15C23-01 Ordering unit: 5 unit 2 x 3 terminals, no terminal access to AUX1 bus, AUX1 interconnected to the left, spring-loaded terminals	6AG1 193-4CB10-7AA0	Accessories for shield connection Shield connection element Ordering unit: 5 units For plugging into TM-E and TM-P	6ES7 193-4GA00-0AA0
SIPLUS ET 200S TM-E15N24-01 Ordering unit: 5 units 2 x 4 terminals, no terminal access to AUX1 bus, AUX1 interconnected to the left, FastConnect	6AG1 193-4CB70-7AA0	Shield clamps Ordering unit: 5 units For busbar 3 x 10 mm	6ES7 193-4GB00-0AA0
SIPLUS ET 200S TM-E15C24-A1 Ordering unit: 5 units 2 x 4 terminals, terminal access to AUX1 bus, AUX1 interconnected to the left, spring-loaded terminals	6AG1 193-4CA30-2AA0	Ground terminal Ordering unit: 1 unit For cable cross-sections up to 25 mm ²	8WA2 868
SIPLUS ET 200S TM-E15C24-01 Ordering unit: 5 unit 2 x 4 terminals, no terminal access to AUX1 bus, AUX1 interconnected to the left, spring-loaded terminals	6AG1 193-4CB30-2AA0	Busbars 3 x 10 mm Ordering unit: 1 unit	8WA2 842
SIPLUS ET 200S TM-E15S26-A1 Ordering unit: 5 units 2 x 6 terminals, terminal access to AUX1 bus, AUX1 interconnected to the left, screw-type terminals	6AG1 193-4CA40-2AA0	Accessories for coding Color coding plates Ordering unit: 200 units for TM-P, TM-E <ul style="list-style-type: none"> • White • Yellow • Yellow/green • Red • Blue • Brown • Turquoise 	6ES7 193-4LA20-0AA0 6ES7 193-4LB20-0AA0 6ES7 193-4LC20-0AA0 6ES7 193-4LD20-0AA0 6ES7 193-4LF20-0AA0 6ES7 193-4LG20-0AA0 6ES7 193-4LH20-0AA0
SIPLUS ET 200S TM-E15C26-A1 Ordering unit: 5 units 2 x 6 terminals, terminal access to AUX1 bus, AUX1 interconnected to the left, spring-loaded terminals	6AG1 193-4CA50-2AA0	Labels, inscribed Ordering unit: 1 set 200 units for slot numbering (1 to 20) 10 x 200 units for slot numbering (1 to 40) 5 x 200 units for slot numbering (1 to 64) 1 x, (1 to 68) 2 x	8WA8 861-0AB 8WA8 861-0AC 8WA8 861-0DA
		Labels, blank 200 units for slot numbering	8WA8 848-2AY

Overview

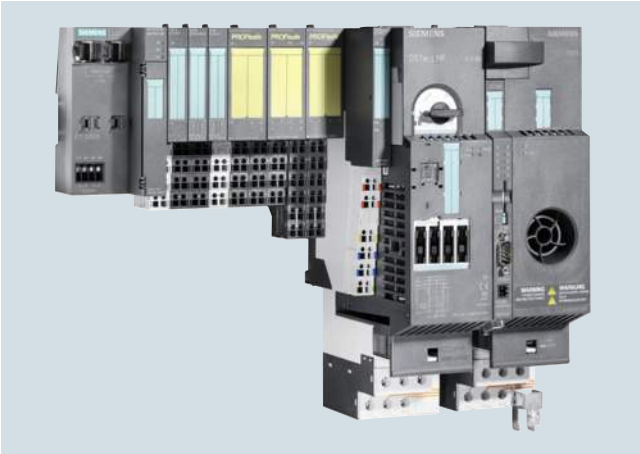

The fail-safe SIMATIC S7 CPUs, plus the fail-safe signal modules of SIMATIC ET 200S / ET200 / 200pro/ ET200eco and ET200M have been specially developed for distributed applications in manufacturing systems. Thanks to the discrete structure of the F I/Os, safety technology is only applied where actually required. The new system replaces conventional electromechanical components, such as:

- Freely programmable safe linking of sensors to actuators;
- Selective safe shutdown of actuators;
- Hybrid configurations of F modules (F stands for fail-safe) and standard modules in a station;
- Single-bus concept, F signals and standard signals are transferred over one bus medium (PROFIBUS DP, PROFINET).

Totally Integrated Automation (TIA)

Safety technology (Safety Integrated) is a component of Totally Integrated Automation resulting in the total integration of safety and standard automation (SIMATIC S7).

Whereas today, standard automation (conventional PLCs) and safety automation (electromechanics) are still separate, these two worlds are growing closer together to form one uniform, integrated overall system.

Siemens can therefore present itself as a complete supplier for automation engineering for which safety technology is part of the standard automation and uniformity exists throughout the complete system.

SIMATIC ET 200 distributed I/O

ET 200S

Fail-safe I/O modules PM-E F PROFIsafe F power module

Overview



Fail-safe PM-E F PROFIsafe power modules for safety shutdown of standard digital output modules.

- Up to 2 fail-safe digital outputs onboard (source/sink outputs, up to 2A, up to SIL3/Cat. 4)
- The standard digital output modules can be shut down up to Cat.3 (EN 954) and SIL 2 (IEC61508) up to 10 A. The following modules can be used down-circuit of the power modules.
 - 2DO / 0.5 A ST 6ES7 132-4BB01-0AA0
 - 2 DO / 2 A ST 6ES7 132-4BB31-0AA0
 - 2 DO / 0.5 A HF 6ES7 132-4BB01-0AB0
 - 2 DO / 2 A HF 6ES7 132-4BB31-0AB0
 - 4 DO / 0.5 A ST 6ES7 132-4BD01-0AA0
 - 4 DO / 2 A ST 6ES7 132-4BD31-0AA0

The modules support PROFIsafe, both in PROFIBUS, and in PROFINET configurations. They can be used with all fail-safe SIMATIC S7-CPU's.

Technical specifications

	6ES7 138-4CF03-0AB0	6ES7 138-4CF42-0AB0
Supply voltage		
Load voltage L+		
• Rated value (DC)	24 V	24 V
• Reverse polarity protection	No	No
Input current		
from load voltage L+ (without load), max.	typ. 100 mA	typ. 100 mA
from backplane bus 24 V DC, max.	28 mA	28 mA
Current carrying capacity		
Current carrying capacity up to 30 °C, max.		10 A
Current carrying capacity up to 40 °C, max.	10 A	8 A
Current carrying capacity up to 60 °C, max.	6 A	7 A
Power losses		
Power loss, typ.	4 W	4 W
Address area		
Address space per module		
• without packing	5 byte; Input and output in each case	5 byte; Input and output in each case
Digital inputs		
Cable length		
• Cable length, shielded, max.	200 m	200 m
• Cable length unshielded, max.	200 m	200 m
Digital outputs		
Number/binary outputs	2	1; Relay
Functionality/short-circuit strength	Yes; Electronic	No
• Response threshold, typ.	Response threshold (short-circuit): 5 to 12 A; response threshold (external short-circuit to ground): 5 to 12 A; response threshold (external short-circuit to P potential): 25 to 45 A	
Limitation of inductive shutdown voltage to	L+ (-2x 47 V)	
Lamp load, max.	10 W	100 W
Controlling a digital input	No	Yes
Load resistance range		
• lower limit	12 Ω	
• upper limit	1 kΩ	
Output voltage		
• for signal "1", min.	L+ (-2,0 V), current sourcing switch: L+ (-1,5 V), voltage drop on current sinking switch: max. 0.5 V	

Technical specifications (continued)

	6ES7 138-4CF03-0AB0	6ES7 138-4CF42-0AB0
Output current		
• for signal "1" rated value	2 A	
• for signal "1" permissible range for 0 to 60 °C, min.	20 mA	
• for signal "1" permissible range for 0 to 60 °C, max.	2.4 A	
• for signal "0" residual current, max.	0.5 mA	
Parallel switching of 2 outputs		
• for increased power	No	
• for redundant control of a load	No	
Switching frequency		
• with resistive load, max.	30 Hz	2 Hz
• with inductive load, max.	0.1 Hz	0.1 Hz; with inductive load to IEC 947-5-1, 13 DC /15 AC
• on lamp load, max.	10 Hz	2 Hz
Aggregate current of outputs (per group)		
• horizontal installation		
- up to 40 °C, max.	10 A	10 A
- up to 55 °C, max.	7 A	8 A
- up to 60 °C, max.	6 A	7 A
• vertical installation		
- up to 40 °C, max.	6 A	8 A
Relay outputs		
• Switching capacity of contacts		
- at ohmic load, up to 50 °C, max.	10 A	10 A
Cable length		
• Cable length, shielded, max.	200 m	
• Cable length unshielded, max.	200 m	
Interrupts/diagnostics/status information		
Diagnostic messages		
• Diagnostic functions	Yes	Yes
• Diagnostic information readable	Yes	Yes
• Diagnostics	Yes	
• Wire break	Yes	No
• Short circuit	Yes	Yes
• Missing load voltage	Yes	Yes
Diagnostics indication LED		
• Rated load voltage PWR (green)	Yes	Yes
• Group error SF (red)	Yes	Yes
• Status indicator digital output (green)	Yes	Yes
Galvanic isolation		
Galvanic isolation digital outputs		
• between the channels	No	No
• between the channels and the backplane bus	Yes	Yes
• between the channels and the load voltage L+	No	No
Isolation		
Isolation checked with	500 V DC	500 V DC
tested with		
• Channels against backplane bus and load voltage L+	500 V DC	500 V DC
Standards, approvals, certificates		
Highest safety class achievable in safety mode		
• acc. to EN 954	4	4
• acc. to IEC 61508	Up to SIL 3	With Std-DO: Max. SIL 2, without Std-DO max. SIL 3 depending on configuration
Dimensions		
Width	30 mm	30 mm
Height	81 mm	81 mm
Depth	52 mm	52 mm
Weight		
Weight, approx.	88 g	80 g

SIMATIC ET 200 distributed I/O

ET 200S

Fail-safe I/O modules

PM-E F PROFIsafe F power module

Ordering data	Order No.	Order No.
Power module PM-E F pm PROFIsafe, 24 V DC For safe shutdown of digital output modules	6ES7 138-4CF03-0AB0	
Power module PM-E F pp PROFIsafe, 24 V DC For safe shutdown of digital output modules	6ES7 138-4CF42-0AB0	
Accessories		
IM 151-1 HIGH FEATURE interface module For ET 200S; transfer rate up to 12 Mbit/s; data volumes 244 bytes each for I/O, up to 63 modules can be connected; connection of PROFIsafe modules, isochronous mode; bus connection via 9-pin Sub-D incl. terminating module	6ES7151-1BA02-0AB0	
IM 151-3 PN HF interface module For ET 200S; transfer rate up to 100 Mbit/s; max. 63 I/O modules up to 2 m wide can be connected; 2 x bus connection via RJ45 connector, incl. terminating module	6ES7 151-3BA23-0AB0	
IM 151-3 PN FO interface module For ET 200S; 2 PROFINET FO interfaces, integrated 2-port switch, max. 63 I/O modules up to 2 m wide can be connected, incl. terminating module	6ES7 151-3BB23-0AB0	
Terminal modules for power modules		
TM-P30S44-A0 Ordering unit 1 item 7 x 2 terminals, terminal access to AUX1 bus, AUX1 interrupted to the left, screw-type terminals for PM-E F PROFIsafe	6ES7 193-4CK20-0AA0	
TM-P30C44-A0 Ordering unit 1 item 7 x 2 terminals, terminal access to AUX1 bus, AUX1 interrupted to the left, spring-loaded terminals for PM-E F PROFIsafe	6ES7 193-4CK30-0AA0	
S7 Distributed Safety programming tool V5.4 Task: Engineering tool for configuring fail-safe user programs for SIMATIC S7-300F, S7-400F, WinAC RTX F, ET 200S, ET 200M, ET 200iSP, ET 200pro, ET 200eco Requirement: STEP 7 V5.3 SP3 and higher Floating license Floating license for 1 user, license key download without software and documentation ¹⁾ ; email address required for delivery	6ES7 833-1FC02-0YA5 6ES7 833-1FC02-0YH5	S7 Distributed Safety Upgrade From V5.x to V5.4; Floating license for 1 user 6ES7 833-1FC02-0YE5
		STEP 7 Safety Advanced V11 Task: Engineering tool for configuring fail-safe user programs for SIMATIC S7-300F, S7-400F, WinAC RTX F, ET 200S, ET 200M, ET 200iSP, ET 200pro, ET 200eco Requirement: STEP 7 Professional V11 SP1 Floating license for 1 user Floating license for 1 user, license key download without software and documentation ¹⁾ ; email address required for delivery
		STEP 7 Safety Advanced Upgrade Distributed Safety V5.4 SP5 and STEP 7 Safety Advanced V11 for parallel use; incl. software on CD; Combo License for 1 user Distributed Safety V5.4 SP5 and STEP 7 Safety Advanced V11 for parallel use; includes software on CD; combo license for 1 user, license key download without software or documentation ¹⁾ ; email address required for delivery
		SIMATIC Manual Collection Electronic manuals on DVD, five languages: S7-200/300/400, C7, LOGO!, SIMATIC DP, PC, PG, STEP 7, engineering software, runtime software, PCS 7, SIMATIC HMI, SIMATIC NET 6ES7 998-8XC01-8YE0
		SIMATIC Manual Collection update service for 1 year 6ES7 998-8XC01-8YE2

¹⁾ For up-to-date information and download availability, see: <http://www.siemens.com/tia-online-software-delivery>

Overview



Digital inputs/outputs for the fail-safe SIMATIC S7 systems

Fail-safe digital input module

- For fail-safe reading of sensor information (1 or 2 channels)
- Provides integral discrepancy evaluation for 2-out-of-2 signals
- 2 internal sensor supplies (incl. test function) onboard
- Certified up to Cat. 4 (EN954-1), SIL 3 (IEC 61508), PL e (ISO 13849)

Fail-safe digital output module

- Fail-safe 2-channel activation (sink/source output) by actuators
- Actuators can be driven by up to 2 A
- Certified up to Cat. 4 (EN954-1), SIL 3 (IEC 61508), PL e (ISO 13849)

Fail-safe digital hybrid module

- 4 fail-safe inputs/3 fail-safe outputs
- Certified up to Cat. 3 (EN954-1), SIL 2 (IEC 61508), PL d (ISO 13849)

The modules support PROFIsafe, both in PROFIBUS, and in PROFINET configurations. They can be used with all fail-safe SIMATIC S7 CPUs.

Technical specifications

6ES7 138-4FA04-0AB0	
Supply voltage	
24 V DC	Yes
permissible range, lower limit (DC)	20.4 V
permissible range, upper limit (DC)	28.8 V
Reverse polarity protection	No
Encoder supply	
Number of outputs	2
Output voltage	min. L+ (-1.5 V)
Output current, rated value	300 mA
Output current, permissible range	0 to 300 mA
Output current	
• Short-circuit protection	Yes; Electronic (response threshold 0.7 A to 1.8 A)
Power losses	
Power loss, typ.	4 W
Address area	
Occupied address area	
• Outputs	4 byte
• Inputs	6 byte
Digital inputs	
Number/binary inputs	8; 8 single channel, 4 two-channel
Input characteristic curve acc. to IEC 61131, Type 1	Yes
Number of simultaneously controllable inputs	8
Input voltage	
• Type of input voltage	DC
• Rated value, DC	24 V
• for signal "0"	-30 to +5 V
• for signal "1"	15 to 30 V
Input current	
• for signal "1", typ.	3.7 mA

6ES7 138-4FA04-0AB0	
Input delay (for rated value of input voltage)	
• for standard inputs	
- Parameterizable	Yes
- at "0" to "1", min.	0.3 ms
- at "0" to "1", max.	17 ms
- at "1" to "0", min.	0.3 ms
- at "1" to "0", max.	17 ms
Cable length	
• Cable length, shielded, max.	200 m
• Cable length unshielded, max.	200 m
Encoder	
Connectable encoders	
• 2-wire sensor	No
Interrupts/diagnostics/status information	
Alarms	
• Diagnostic alarm	Yes
Diagnostic messages	
• Diagnostic functions	Yes
• Diagnostic information readable	Yes
• Short circuit	Yes
Diagnostics indication LED	
• Group error SF (red)	Yes
• Status indicator digital input (green)	Yes
Galvanic isolation	
Galvanic isolation digital inputs	
• between the channels	No
• between the channels and the backplane bus	Yes
• between the channels and the load voltage L+	No
Permissible potential difference	
between M internally and the inputs	75 VDC / 60 VAC

SIMATIC ET 200 distributed I/O

ET 200S

Fail-safe I/O modules F electronic modules

Technical specifications (continued)

6ES7 138-4FA04-0AB0	
Isolation	
Isolation checked with	500 V DC
Standards, approvals, certificates	
Highest safety class achievable in safety mode	
• acc. to EN 954	4
• acc. to IEC 61508	SIL 2 (single-channel), SIL 3 (two-channel)

6ES7 138-4FB03-0AB0	
Supply voltage	
Load voltage L+	
• Rated value (DC)	24 V
• Reverse polarity protection	No
Input current	
from load voltage L+ (without load), max.	typ. 100 mA
from backplane bus 3.3 V DC, max.	28 mA
Power losses	
Power loss, typ.	3.5 W
Digital outputs	
Number/binary outputs	4
Functionality/short-circuit strength	Yes; Electronic
Limitation of inductive shutdown voltage to	Typ. (2L+) -47 V
Lamp load, max.	10 W
Controlling a digital input	No
Load resistance range	
• lower limit	12 Ω
• upper limit	1 kΩ
Output voltage	
• for signal "1", min.	L+ (-2,0 V), current sourcing switch: L+ (-1,5 V), voltage drop on current sinking switch: max. 0.5 V
Output current	
• for signal "1" rated value	2 A
• for signal "1" permissible range for 0 to 60 °C, min.	20 mA
• for signal "1" permissible range for 0 to 60 °C, max.	2.4 A
• for signal "0" residual current, max.	0.5 mA; Current-sourcing: max. 0.5 mA; Current sinking: max. 4 mA
Parallel switching of 2 outputs	
• for increased power	No
• for redundant control of a load	No
Switching frequency	
• with resistive load, max.	30 Hz
• with inductive load, max.	0.1 Hz
• on lamp load, max.	10 Hz
Aggregate current of outputs (per group)	
• horizontal installation	
- up to 40 °C, max.	6 A
- up to 55 °C, max.	5 A
- up to 60 °C, max.	4 A
• vertical installation	
- up to 40 °C, max.	4 A
Cable length	
• Cable length, shielded, max.	200 m
• Cable length unshielded, max.	200 m

6ES7 138-4FA04-0AB0	
Dimensions	
Width	30 mm
Height	81 mm
Depth	52 mm
Weight	
Weight, approx.	78 g

6ES7 138-4FB03-0AB0	
Interrupts/diagnostics/status information	
Diagnostic messages	
• Diagnostic functions	Yes
• Wire break	Yes
• Short circuit	Yes
Diagnostics indication LED	
• Group error SF (red)	Yes
• Status indicator digital output (green)	Yes
Galvanic isolation	
Galvanic isolation digital outputs	
• between the channels	No
• between the channels and the backplane bus	Yes
• between the channels and the load voltage L+	No
Isolation	
Isolation checked with	500 V DC
tested with	
• Channels against backplane bus and load voltage L+	1500 V AC
Standards, approvals, certificates	
Highest safety class achievable in safety mode	
• acc. to EN 954	4
• acc. to IEC 61508	SIL 3
Dimensions	
Width	30 mm
Height	81 mm
Depth	52 mm
Weight	
Weight, approx.	85 g

Ordering data	Order No.	Order No.
Electronic module 4/8 F-DI PROFIsafe 24 V DC 30 mm construction width, up to Category 4 (EN954-1)	6ES7 138-4FA04-0AB0	
Electronic module 4 F-DO PROFIsafe 24 V DC/2A 30 mm construction width, up to Category 4 (EN954-1)	6ES7 138-4FB03-0AB0	
Electronic module 4 F-DI / 3 F-DO PROFIsafe 24 V DC/2A 30 mm construction width, up to Category 3 (EN954-1) / SIL 2 (IEC 62061)	6ES7 138-4FC01-0AB0	
Accessories Terminal modules for electronic modules	See F terminal modules, page 9/142	
IM 151-1 High Feature interface module For ET 200S; transmission rate up to 12 Mbit/s; max. 63 modules can be connected, with isochronous mode, bus connection via 9-pin Sub-D connector incl. terminating module	6ES7 151-1BA02-0AB0	
IM 151-3 PN HF interface module For ET 200S; transfer rate up to 100 Mbit/s; max. 63 I/O modules up to 2 m wide can be connected; 2 x bus connection via RJ45 connector, incl. terminating module	6ES7 151-3BA23-0AB0	
IM 151-3 PN FO interface module For ET 200S; 2 PROFINET FO interfaces, integrated 2-port switch, max. 63 I/O modules up to 2 m wide can be connected, incl. terminating module	6ES7 151-3BB23-0AB0	
S7 Distributed Safety programming tool V5.4 Task: Engineering tool for configuring fail-safe user programs for SIMATIC S7-300F, S7-400F, WinAC RTX F, ET 200S, ET 200M, ET 200iSP, ET 200pro, ET 200eco Requirement: STEP 7 V5.3 SP3 and higher Floating license	6ES7 833-1FC02-0YA5	S7 Distributed Safety Upgrade From V5.x to V5.4; Floating license for 1 user 6ES7 833-1FC02-0YE5
Floating license for 1 user, license key download without software and documentation ¹⁾ ; email address required for delivery	6ES7 833-1FC02-0YH5	STEP 7 Safety Advanced V11 Task: Engineering tool for configuring fail-safe user programs for SIMATIC S7-300F, S7-400F, WinAC RTX F, ET 200S, ET 200M, ET 200iSP, ET 200pro, ET 200eco Requirement: STEP 7 Professional V11 SP1 Floating license for 1 user Floating license for 1 user, license key download without software and documentation ¹⁾ ; email address required for delivery
		STEP 7 Safety Advanced Upgrade Distributed Safety V5.4 SP5 and STEP 7 Safety Advanced V11 for parallel use; incl. software on CD; Combo License for 1 user Distributed Safety V5.4 SP5 and STEP 7 Safety Advanced V11 for parallel use; includes software on CD; combo license for 1 user, license key download without software or documentation ¹⁾ ; email address required for delivery
		SIMATIC Manual Collection Electronic manuals on DVD, multi-language: S7-200, TD 200, S7-300, M7-300, C7, S7-400, M7-400, STEP 7, Engineering Tools, Runtime Software, SIMATIC DP (Distributed I/O), SIMATIC HMI (Human Machine Interface), SIMATIC NET (Industrial Communication)
		SIMATIC Manual Collection – Update service for 1 year Scope of delivery: Current DVD "S7 Manual Collection" and the three subsequent updates
		6ES7 833-1FA11-0YA5 6ES7 833-1FA11-0YH5 6ES7 833-1FA11-0YE5 6ES7 833-1FA11-0YK5 6ES7 998-8XC01-8YE0 6ES7 998-8XC01-8YE2

¹⁾ For up-to-date information and download availability, see: <http://www.siemens.com/tia-online-software-delivery>

SIMATIC ET 200 distributed I/O

ET 200S

Fail-safe I/O modules F electronic module relays

Overview



The digital electronic module 1 F-RO 24 V DC/5A 24 to 230 V AC/5A has the following characteristics

- 1 relay output (2 NO contacts)
- Output current 5 A.
- Rated load voltage 24 V DC and 24 to 230 V AC
- The control circuit of the two safety relays must be routed from the outside to the respective terminals.

The attainable safety integrity level is SIL3 (IEC61508), when the control of the F-RO module is implemented via a fail-safe output (e.g. EM 4F-DO 24 V DC/2A PROFIsafe).

Technical specifications

6ES7 138-4FR00-0AA0	
Supply voltage	
Load voltage L+ • Rated value (DC)	24 V; Supply via fail-safe output, e.g. of an F-DO
Input current	
from load voltage L+ (without load), max.	100 mA; from control voltage
from backplane bus 3.3 V DC, max.	10 mA
Power losses	
Power loss, typ.	2.1 W
Address area	
Address space per module	
• with packing	2 bit
• without packing	1 byte
Digital inputs	
Cable length	
• Cable length unshielded, max.	10 m; control cable
Digital outputs	
Number/binary outputs	1
Functionality/short-circuit strength	No; 6 A external fuse of duty category gL/gG
Controlling a digital input	Yes
Output current	
• for signal "1" rated value	5 A
• for signal "1" minimum load current	5 mA
Switching frequency	
• with resistive load, max.	2 Hz
• with inductive load, max.	0.1 Hz
Aggregate current of outputs (per group)	
• horizontal installation	
- up to 40 °C, max.	8 A
- up to 55 °C, max.	6 A; At 50 °C
- up to 60 °C, max.	5 A; up to max. 24.8 V
• vertical installation	
- up to 40 °C, max.	6 A

6ES7 138-4FR00-0AA0	
Relay outputs	
• Switching capacity of contacts - Thermal continuous current, max.	5 A
Cable length	
• Cable length, shielded, max.	200 m
• Cable length unshielded, max.	200 m
Interrupts/diagnostics/status information	
Diagnostics indication LED	
• Status indicator digital output (green)	Yes
Galvanic isolation	
Galvanic isolation digital outputs	
• between the channels	Yes
• between the channels and the backplane bus	Yes
• between the channels and the load voltage L+	Yes; between channels and control voltage
Standards, approvals, certificates	
Highest safety class achievable in safety mode	
• acc. to EN 954	4
• acc. to IEC 61508	Up to SIL 3
Dimensions	
Width	30 mm
Height	81 mm
Depth	52 mm
Weight	
Weight, approx.	90 g

Ordering data	Order No.	Order No.
Electronic module 1 F-RO 24 V DC/5A 24 to 230 V AC/5A	6ES7 138-4FR00-0AA0	
Accessories		
Terminal modules for electronic modules	See F terminal modules, page 9/142	
IM 151-1 High Feature interface module	6ES7 151-1BA02-0AB0	
For ET 200S; transmission rate up to 12 Mbit/s; max. 63 modules can be connected, with isochronous mode, bus connection via 9-pin Sub-D connector incl. terminating module		
IM 151-3 PN HF interface module	6ES7 151-3BA23-0AB0	
For ET 200S; transfer rate up to 100 Mbit/s; max. 63 I/O modules up to 2 m wide can be connected; 2 x bus connection via RJ45 connector, incl. terminating module		
IM 151-3 PN FO interface module	6ES7 151-3BB23-0AB0	
For ET 200S; 2 PROFINET FO interfaces, integrated 2-port switch, max. 63 I/O modules up to 2 m wide can be connected, incl. terminating module		
S7 Distributed Safety programming tool V5.4		
Task: Engineering tool for configuring fail-safe user programs for SIMATIC S7-300F, S7-400F, WinAC RTX F, ET 200S, ET 200M, ET 200iSP, ET 200pro, ET 200eco		
Requirement: STEP 7 V5.3 SP3 and higher		
Floating license	6ES7 833-1FC02-0YA5	
Floating license for 1 user, license key download without software and documentation ¹⁾ ; email address required for delivery	6ES7 833-1FC02-0YH5	
		S7 Distributed Safety Upgrade
		From V5.x to V5.4; Floating license for 1 user
		STEP 7 Safety Advanced V11
		Task: Engineering tool for configuring fail-safe user programs for SIMATIC S7-300F, S7-400F, WinAC RTX F, ET 200S, ET 200M, ET 200iSP, ET 200pro, ET 200eco
		Requirement: STEP 7 Professional V11 SP1
		Floating license for 1 user
		Floating license for 1 user, license key download without software and documentation ¹⁾ ; email address required for delivery
		STEP 7 Safety Advanced Upgrade
		Distributed Safety V5.4 SP5 and STEP 7 Safety Advanced V11 for parallel use; incl. software on CD; Combo License for 1 user
		Distributed Safety V5.4 SP5 and STEP 7 Safety Advanced V11 for parallel use; includes software on CD; combo license for 1 user, license key download without software or documentation ¹⁾ ; email address required for delivery
		SIMATIC Manual Collection
		Electronic manuals on DVD, multi-language: S7-200, TD 200, S7-300, M7-300, C7, S7-400, M7-400, STEP 7, Engineering Tools, Runtime Software, SIMATIC DP (Distributed I/O), SIMATIC HMI (Human Machine Interface), SIMATIC NET (Industrial Communication)
		SIMATIC Manual Collection – Update service for 1 year
		Scope of delivery: Current DVD "S7 Manual Collection" and the three subsequent updates
		6ES7 833-1FA11-0YA5
		6ES7 833-1FA11-0YH5
		6ES7 833-1FA11-0YE5
		6ES7 833-1FA11-0YK5
		6ES7 998-8XC01-8YE0
		6ES7 998-8XC01-8YE2

¹⁾ For up-to-date information and download availability, see:
<http://www.siemens.com/tia-online-software-delivery>

SIMATIC ET 200 distributed I/O

ET 200S

Fail-safe I/O modules
F terminal modules

Overview



- Mechanical modules as receptacles for the electronic modules
- For setting up permanent wiring through self-configuring voltage buses
- Keyed connection technology to ensure an enhanced vibration resistance of up to 5 g
- Different versions to accommodate power modules and electronic modules
- Replaceable terminal box (even within the station network)
- Automatic coding of the electronic modules
- Self-shielding of the backplane bus for high data security
- Color coding facility for the terminals and for identifying the slot numbers
- Alternatively available with screw-type or spring-loaded terminals
- For up to 60 % faster process wiring also with FastConnect connection method (av. soon)

Ordering data

Order No.

**Terminal modules
for power modules****TM-P15S23-A1**

2 × 3 terminals, terminal access to AUX1 bus, AUX1 interconnected to the left, screw-type terminals

Ordering unit 1 item

6ES7 193-4CC20-0AA0

Ordering unit 5 items

6ES7 193-4CC20-1AA0

TM-P15C23-A1

2 × 3 terminals, terminal access to AUX1 bus, AUX1 interconnected to the left, spring-loaded terminals

Ordering unit 1 item

6ES7 193-4CC30-0AA0

Ordering unit 5 items

6ES7 193-4CC30-1AA0

TM-P15S23-A0

2 × 3 terminals, terminal access to AUX1 bus, AUX1 interrupted to the left, screw-type terminals

Ordering unit 1 item

6ES7 193-4CD20-0AA0

Ordering unit 5 items

6ES7 193-4CD20-1AA0

TM-P15C23-A0

2 × 3 terminals, terminal access to AUX1 bus, AUX1 interrupted to the left, spring-loaded terminals

Ordering unit 1 item

6ES7 193-4CD30-0AA0

Ordering unit 5 items

6ES7 193-4CD30-1AA0

TM-P15S22-01

2 × 2 terminals, no terminal access to AUX1 bus, AUX1 interconnected to the left, screw-type terminals

Ordering unit 1 item

6ES7 193-4CE00-0AA0

Ordering unit 5 items

6ES7 193-4CE00-1AA0

TM-P15C22-01

2 × 2 terminals, no terminal access to AUX1 bus, AUX1 interconnected to the left, spring-loaded terminals

Ordering unit 1 item

6ES7 193-4CE10-0AA0

Ordering unit 5 items

6ES7 193-4CE10-1AA0

TM-P30S44-A0

Ordering unit 1 item
7 × 2 terminals, terminal access to AUX1 bus, AUX1 interrupted to the left, screw-type terminals for PM-E F PROFIsafe

6ES7 193-4CK20-0AA0

TM-P30C44-A0

Ordering unit 1 item
7 × 2 terminals, terminal access to AUX1 bus, AUX1 interrupted to the left, spring-loaded terminals for PM-E F PROFIsafe

6ES7 193-4CK30-0AA0

Ordering data	Order No.	Ordering data	Order No.
Terminal modules for electronic modules TM-E30S44-01 Ordering unit 1 item 4 x 4 terminals, no terminal access to AUX1 bus, AUX1 interconnected to the left, screw-type terminals	6ES7 193-4CG20-0AA0	Accessories Color coding plates Ordering unit 200 pieces for TM-P, TM-E <ul style="list-style-type: none"> • white • yellow • yellow/green • red • blue • brown • turquoise 	6ES7 193-4LA20-0AA0 6ES7 193-4LB20-0AA0 6ES7 193-4LC20-0AA0 6ES7 193-4LD20-0AA0 6ES7 193-4LF20-0AA0 6ES7 193-4LG20-0AA0 6ES7 193-4LH20-0AA0
TM-E30C44-01 Ordering unit 1 item 4 x 4 terminals, no terminal access to AUX1 bus, AUX1 interconnected to the left, spring-loaded terminals	6ES7 193-4CG30-0AA0	Grounding terminal Ordering unit 1 item For cable cross-sections up to 25 mm ²	8WA2 868
TM-E30S46-A1 Ordering unit 1 item 4 x 6 terminals, terminal access to AUX1 bus, AUX1 interconnected to the left, screw-type terminals	6ES7 193-4CF40-0AA0	3 x 10 mm busbars Ordering unit 1 item	8WA2 842
TM-E30C46-A1 Ordering unit 1 item 4 x 6 terminals, terminal access to AUX1 bus, AUX1 interconnected to the left, spring-loaded terminals	6ES7 193-4CF50-0AA0	Labels, inscribed Ordering unit 1 set <ul style="list-style-type: none"> • 200 items for slot numbering (1 to 20) 10 x • 200 items for slot numbering (1 to 40) 5 x • 200 items for slot numbering (1 to 64) 1 x, (1 to 68) 2 x 	8WA8 861-0AB 8WA8 861-0AC 8WA8 861-0DA
		Labels, blank 200 items for slot numbering	8WA8 848-2AY

SIMATIC ET 200 distributed I/O

ET 200S

Fail-safe I/O modules
SIPLUS F electronic modules

Overview



Digital inputs/outputs for the fail-safe SIMATIC S7 systems

Fail-safe digital input module

- For fail-safe reading of sensor information (1 or 2 channels)
- Provides integral discrepancy evaluation for 2-out-of-2 signals
- 2 internal sensor supplies (incl. test function) onboard

Fail-safe digital output module

- Fail-safe 2-channel activation (sink/source output) by actuators
- Actuators can be controlled up to 2 A

All modules are certified up to Cat. 4 (EN 954-1) and up to SIL 3 (IEC 61508).

The modules support PROFIsafe, in both PROFIBUS and PROFINET configurations.

They can be used with all fail-safe SIMATIC S7-CPU's.

Note:

SIPLUS extreme products are based on Siemens Industry standard products. The contents listed here were taken from the respective standard products. SIPLUS extreme specific information was added.

	SIPLUS electronic module 4 F-DO, PROFIsafe 24 V DC/2 A	SIPLUS electronic module 4/8 F-DI, PROFIsafe 24 V DC
Order number	6AG1 138-4FA04-2AB0	6AG1 138-4FB03-2AB0
Order No. based on	6ES7 138-4FA04-0AB0	6ES7 138-4FB03-0AB0
Ambient temperature range	-25 ... +60 °C	
Conformal coating	Coating of the printed circuit boards and the electronic components	
Technical data	The technical data of the standard product applies except for the ambient conditions.	
Ambient conditions		
Relative humidity	100%, condensation/frost permissible. No commissioning if condensation present.	

For technical documentation on SIPLUS, see:
<http://www.siemens.com/siplus-extreme>

Ordering data	Order No.	Accessories	Order No.
F electronic modules SIPLUS (extended temperature range and medial exposure)			See SIMATIC F electronic modules, page 9/139
4/8 F DI electronic module, PROFIsafe 24 V DC, 30 mm construction width, up to Category 4 (EN 954-1)	6AG1 138-4FA04-2AB0		
4 F-DO electronic module, PROFIsafe 24 V DC/2 A, 30 mm construction width, up to Category 4 (EN 954-1)	6AG1 138-4FB03-2AB0		

SIMATIC ET 200 distributed I/O

ET 200S

IO-Link master modules
4SI IO-Link electronic module

Overview



The 4SI IO-Link electronic module is an IO-Link master and supports the easy integration of sensors and actuators from different manufacturers in the multifunctional, distributed I/O system SIMATIC ET 200S on a total of four ports.

Features

- Up to 4 IO-Link devices can be connected to each IO-Link master module (3-wire connection)
- Up to 4 standard actuators or sensors (2-wire/3-wire connection) can be connected.
- The 4SI IO-Link electronic module is 15 mm in width and can be used with the following universal terminal modules:
 - TM-E15S26-A1 (screw-type terminal)
 - TM-E15C26-A1 (spring-loaded terminal)
 - TM-E15N26-A1 (FastConnect)
- Supports firmware update (STEP 7 V5.4 SP4 and higher)

Ordering data

Order No.

4SI IO-Link electronic module

IO-Link master, screw terminal, spring-loaded terminal or FastConnect connection method

6ES7 138-4GA50-0AB0

Accessories

Universal terminal module for ET 200S

- TM-E15S26-A1 with screw terminal
- TM-E15C26-A1 with spring-loaded terminal
- TM-E15N26-A1 with FastConnect

6ES7 193-4CA40-0AA0

6ES7 193-4CA50-0AA0

6ES7 193-4CA80-0AA0

SIMATIC ET 200 distributed I/O

ET 200S

IO-Link master modules 4SI SIRIUS electronic module

Overview



The 4SI SIRIUS electronic module supports easy, cost-effective connection of SIRIUS switching devices with IO-Link to the multi-functional, distributed I/O system SIMATIC ET 200S on a total of four ports.

Features

- Up to 4 SIRIUS devices can be connected to the 4 ports of each 4SI SIRIUS electronic module. 3RA6 compact starters or load feeders with 3RA27 function modules can even be bundled in groups of 4 devices each at an IO-Link port. This means that up to 16 load feeders can be connected to the controller at an IO-Link master module.
- The 4SI SIRIUS electronic module is 15 mm in width and can be used with the following universal terminal modules:
 - TM-E15S26-A1 (screw terminal)
 - TM-E15C26-A1 (spring-loaded terminal)
 - TM-E15N26-A1 (FastConnect)
- Supports firmware updates (STEP 7 V5.4 SP5 and higher)

Ordering data

Order No.

4SI SIRIUS electronic module

3RK1 005-0LB00-0AA0

For the connection of SIRIUS switching devices to ET 200S; 4 ports. Screw terminal, spring-loaded terminal, or FastConnect connection method

Accessories

Universal terminal module for ET 200S

- TM-E15S26-A1 with screw terminal
- TM-E15C26-A1 with spring-loaded terminal
- TM-E15N26-A1 with FastConnect

6ES7 193-4CA40-0AA0

6ES7 193-4CA50-0AA0

6ES7 193-4CA80-0AA0

ET 200S manual for 4SI SIRIUS electronic module

- German

3ZX1 012-0LB00-0AA0

Note:

This manual is also available at <http://support.automation.siemens.com/WW/view/en/37856470>

Overview

ET 200S motor starters in the ET 200S I/O system

The SIMATIC ET 200S is the multifunctional and bit-modular I/O system in degree of protection IP20 for exact adaptation to the automation task.

Interface modules (IM) are used for connecting the ET 200S to PROFIBUS DP or PROFINET. If interface modules with integrated S7-CPU are used, the ET 200S can act as a small control system.

The ET 200S is designed for combining with a large range of digital and analog input or output modules, technology modules, IO-Link master modules, pneumatic connections, or motor starters and frequency converters for the control of drives.

Device replacement is easy and quick thanks to permanent wiring and automatic re-parameterization.

Hot swapping, i.e. the disconnection and connection of modules without prior isolation, ensures high availability of the automation system along with extensive diagnostics information.

The ET 200S motor starters are connected to the control system and parameterized via the fieldbus using either PROFIBUS or PROFINET via IM modules – available in both standard and safety-related versions.

With the ET 200S motor starters, any three-phase current loads can be protected and switched. The communications interface makes them ideal for operation in distributed control cabinets or control boxes.

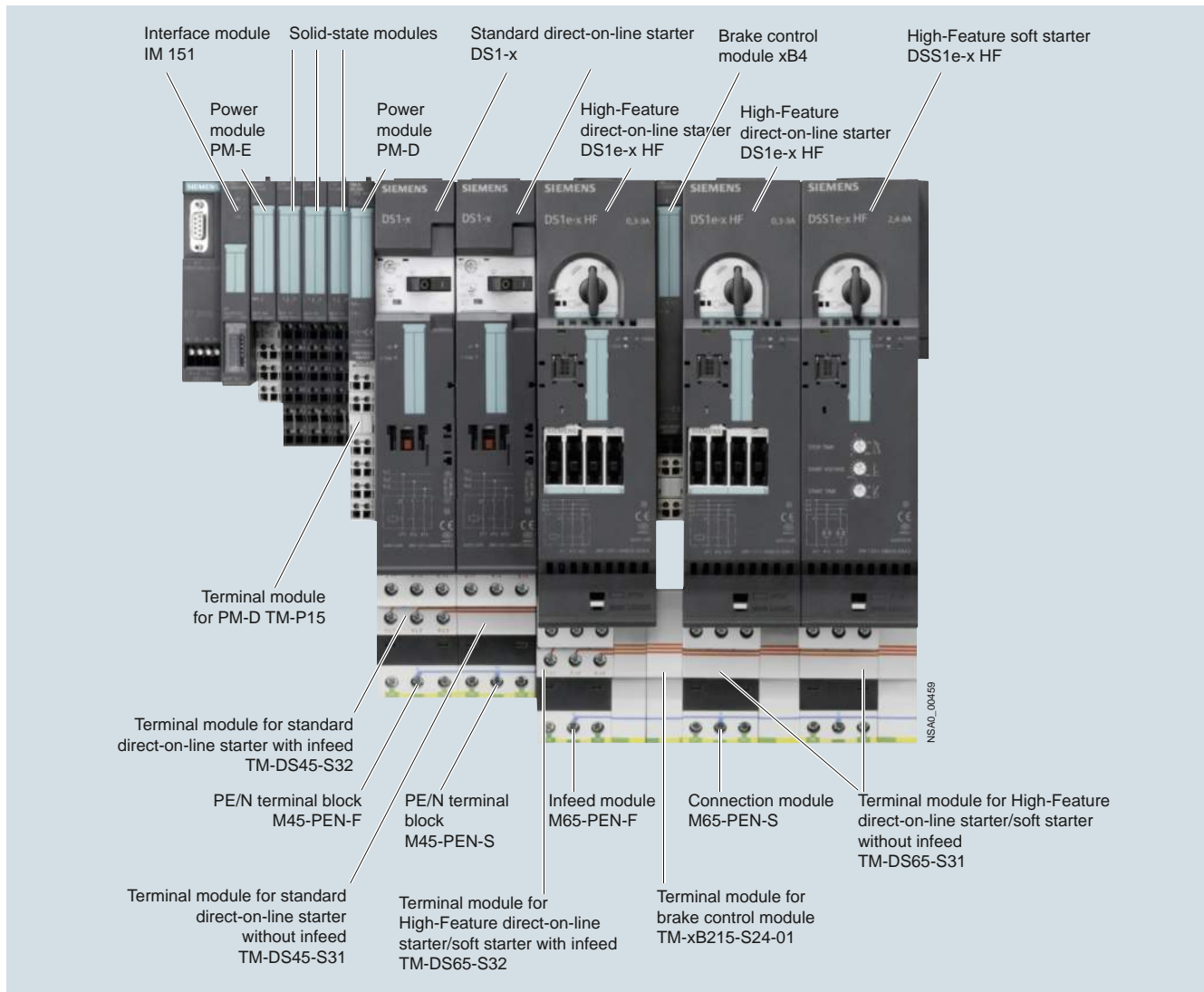

Interaction of the ET 200S motor starter components in the ET 200S I/O system

Motor starter types

The ET 200S motor starters are available as direct-on-line, reversing, or soft starter versions:

- **Standard motor starters** up to 5.5 kW (direct-on-line and reversing starters)
- **High Feature motor starters** up to 7.5 kW (direct-on-line, reversing and direct-on-line soft starters)
- **Failsafe motor starters** up to 7.5 kW (direct-on-line and reversing starters)
 - Properties of the High Feature motor starter
 - Failsafe functionality

SIMATIC ET 200 distributed I/O

ET 200S

Motor starters and safety motor starters General data

Innovation of the ET 200S High Feature motor starters

The ET 200S High Feature motor starters have undergone radical innovation and now support the acyclic services on PROFIBUS and PROFINET as well as PROFlenergy on PROFINET.

They are now:

- Even more flexible – flexible assignment of parameters
- Even better integrated in TIA (Totally Integrated Automation)
- Even more transparent – through comprehensive diagnostic data records
- Even more anticipatory – through maintenance functions
- Energy-efficient – through PROFlenergy

Basic functionality of the ET 200S motor starters

All versions of the ET 200S motor starters have the following functionality. The further specific functionality is described for the respective versions.

- Fully pre-wired motor starters for switching and protecting any AC loads up to 7.5 kW at 400 V AC and 500 V AC
- With self-assembling 40/50 A power bus, i.e. the load voltage is only fed once for a group of motor starters
- All supply voltages are connected only once, i.e. when modules are added, they are automatically connected to the next module
- Hot swapping is permissible
- Integrated inputs and outputs for control and status signaling
- Control of the motor starter from the control system and extensive diagnostics status via the cyclic process image
- Diagnostics capability for active monitoring of the switching and protection functions
- The signal states in the process image of the motor starter provide information about protective devices (short-circuit or overload), the switching states of contactor(s) or soft starters, and system faults.
- Interface for controlling an expansion module, e. g. brake control module xB1...xB4 for controlling mechanical brakes in three-phase motors for 24 V DC and 500 V DC.
- Brake control module xB5 and xB6 for 400 V AC
- Can be combined with safety technology for use in safety-related system components (IEC 62061 and ISO 13849-1)

Mounting

As the motor starters are fully pre-wired, up to 80% of the wiring outlay can be saved. The control cabinets can be assembled far more quickly and compactly.

Expansions are easily possible through the subsequent adding of terminal modules. Due to their modular terminal design (10 mm²), they also replace any previously required marshaling wiring. Through the permanent wiring and the "hot swapping" function (disconnection and connection during operation) a motor starter can be replaced within seconds if necessary. The motor starters are therefore recommendable in particular for applications with special demands on availability.

Parameterization and configuration

Configuration is made easier by the bit-modular structure.

When using the ET 200S motor starters, the list of parts per load feeder is reduced to two main items: the passive terminal module and the motor starter. This makes the ET 200S ideal for modular machine concepts as well.

All ET 200S motor starters are set up without fuses. Contactors and soft starters are activated through the integrated outputs. The inputs of the motor starters evaluate the signal states of the protective devices (short-circuit or overload), the switching states of contactor(s) or soft starters, and system faults.

The motor starter protector signaling is freely programmable with regard to group fault signals (group fault at motor starter protector "Off"/group fault signal at motor starter protector "Off" only in case of "On" command from the motor starter).

Brake control modules and optional digital inputs and outputs

With one of the optional brake control modules (xB1-xB6), which is butt-mounted to the right of a motor starter, it is possible to control a mechanical holding brake on a three-phase motor from the process image of the motor starter.

Motors with 24 V DC brakes (xB1, xB3) as well as motors with 500 V DC brakes (xB2, xB4) can be controlled using the brake control modules xB1-xB4.

The modules xB5 (without digital input) and xB6 (with two digital inputs) have been added to the range in order to control a mechanical holding brake with a rated operational voltage of 400 V AC. A further motor brake voltage commonly found on the market is thus supported.

The 24 V DC brakes have an external supply and can be vented independently of the switching state of the motor starter. By contrast, the 500 V DC brakes and the 400 V AC brakes usually have a direct supply from the terminal board of the motor through a rectifier module and therefore cannot be vented when the motor starter is switched off. These brakes cannot be used in combination with the DSS1e-x motor starter (soft starter).

The outputs of the brake control modules can be used alternatively for other purposes, e.g. for controlling DC valves.

With two digital inputs available on the brake control modules (xB3, xB4, xB6) and another two digital inputs available on the optional control module it is possible to realize autonomous special functions which work independently of the bus and the higher-level control system, e.g. as a quick stop on gate valve controls. The signals of these digital inputs are in the process image and are reported to the control system.

Power supply through terminal module

Power is supplied through the terminal modules for motor starters:

- the auxiliary voltages are fed in only once via the PM-D or PM-DFx power module which must be connected to the left of the first motor starter.
- The load voltage is fed in at the first (left) TM-xxxxS32 terminal module of a motor starter. The other TM-xxxxS31 terminal modules are automatically supplied with power through the integrated power bus when they are mounted side by side. If the power bus is utilized to its full capacity of 40 A for Standard motor starters or 50 A for High Feature motor starters, a new supply must be fed in through an additional TM-xxxxS32 terminal module.

TM-DS and TM-RS terminal modules for motor starters

- Mechanical modules in which the motor starter and expansion modules are inserted
- For constructing the permanent wiring and self-assembling voltage buses
- For connecting the motor connection cables
- Positive-locking connection to ensure enhanced vibration resistance

Terminal modules are purely mechanical components for accommodating the ET 200S peripherals. The self-assembling voltage buses integrated into the terminal modules reduce wiring outlay to the single infeed (both of auxiliary and load voltage). All modules following on the right are automatically supplied upon plugging the terminal modules together. The robust design and keyed connection technology enables use in harsh industrial conditions.

The TM-DS and TM-RS terminal modules are available in various versions for the Standard motor starters and the High Feature motor starters.

Terminal modules with the suffix "-S32"

- The terminal modules with the suffix "-S32" have connection terminals for feeding into the integrated 40A/50A power bus and connection terminals for the motor connection cable. They are mounted at the beginning (left) of a power bus segment.
- To configure a new load group, another "-S32" terminal module is plugged in.
- The "-S32" terminal modules are supplied with three caps for closing the power bus contacts on the final terminal module of a segment.
- Optionally expandable with PE/N blocks

Terminal modules with the suffix "-S31"

- The terminal modules with the suffix "-S31" have only connection terminals for the motor connection cable. These terminal modules follow on the right after a "-S32" terminal module.
- Optionally expandable with PE/N blocks

All connection terminals of the terminal modules for motor starters are equipped with strong 10 mm² screw terminals.

Power module (page 9/159)

PM-D power modules are used for monitoring the two 24 V DC auxiliary voltages for the group of motor starters following on the right or for supplying power to the group of frequency converters following on the right.

TM-P terminal module for PM-D power module (page 9/160)

- Connection using screw-type terminals
- Light colored enclosure for visual distinction
- Always before the first TM-DS/TM-RS

ET 200S Safety motor starters with integrated safety technology

The safety-related, communication-capable ET 200S motor starters offer the right solution for every safety application. The range extends from the simple local safety solution down to the user-friendly variant with PROFI-safe that can be used in conjunction with a safe control system (see "Safety modules local and PROFI-safe", page 9/164).

The safety engineering is an integral part and is therefore pre-wired at the factory.

The ET 200S Safety motor starters Solutions comprise:

- Safety modules (page 9/165)
- Standard motor starters (page 9/153)
- High Feature motor starters (page 9/156)
- Failsafe motor starters (page 9/161)

System configuration with ET 200S motor starters

When constructing an ET 200S station with motor starters a distinction can be made between the following configurations:

- Conventional ET 200S motor starter solution consisting of:
 - PM-D module
 - Standard motor starter or High Feature motor starter
- ET 200S Safety motor starter Solution local (see page 9/164)
- ET 200S Safety motor starter Solutions PROFI-safe (see page 9/168)

SIRIUS motor starter block library for SIMATIC PCS 7

With the SIRIUS motor starter PCS 7 block library, SIRIUS ET 200S motor starters (direct-on-line and reversing starters, direct-on-line soft starters) can be easily and simply integrated into the SIMATIC PCS 7 process control system. The SIRIUS motor starter PCS 7 function block library contains the diagnostics and driver blocks corresponding with the diagnostics and driver concept of SIMATIC PCS 7 as well as the elements required for operation and monitoring (symbols and faceplates), see Catalog IC 10, Chapter "Parametrization, Configuration and Visualization with SIRIUS".

Configuration tool for ET 200S station

The "SIMATIC Selection Tool" enables the fast and accurate selection of SIMATIC hardware. It is available as a configurator in the Siemens Industry Mall free of charge. Set your stations (for B. S7-1200, S7-300, S7-400, S7-400H) together and select the desired distributed I/O (for B. ET 200S, ET 200pro). You can transfer the parts list you received to the Industry Mall shopping cart and place your order quickly, conveniently and with no problems.

You can find detailed information about the ET 200S system at:

www.siemens.com/ET200S

Here you will find a link to the SIMATIC Selection Tool.

SIMATIC ET 200 distributed I/O

ET 200S

Motor starters and safety motor starters

General data



SIMATIC ET 200S
Standard motor starters

SIMATIC ET 200S
High Feature motor starters¹⁾

Device functions (firmware features)

Slave on the bus

Fieldbus ✓ Dependent on interface module

Parameterization

PROFIBUS/PROFINET data records -- ✓

Parameterization using data record start -- ✓

Diagnostics

Acyclic through data records -- ✓

Diagnostic interrupt support ✓

Diagnostics using PROFIBUS/PROFINET -- ✓ See manual²⁾

Process image

Process image ✓ 3I/3O ✓ 16I/7O

Address space required per module ✓ 4 bits ✓ 2 bytes

Data channels

Manual mode local interface -- ✓ Through module

Motor Starter ES via local interface -- ✓ Starting end of 2011

Motor Starter ES via bus -- ✓ Starting end of 2011

Data records (acyclic)

Parameterization -- ✓

Support for PROFlenergy profile -- ✓ Measuring the motor current and disconnection in idle times

Diagnostics -- ✓

Measured values -- ✓

Statistics -- ✓

Commands -- ✓

Slave pointer -- ✓

Logbook -- ✓

Device identification -- ✓

I&M data -- ✓

Inputs

Number ✓ Maximum 2, via xB3, xB4, xB6 ✓ Maximum 4, 2 via xB3, xB4, xB6 and 2 via module 2DI 24 V DC COM

• Of which in the process image -- ✓ 4

Input action ✓ End position on left, right ✓ Parameterizable: flexible

Quick stop -- ✓ Parameterizable

Outputs

Number ✓ Internal, for controlling the brake module

Output action ✓ Brake

Brake output with additional module

Motor brake voltage: brake module ✓ 24 V DC: xB1/xB3, 500 V DC: xB2/xB4, 400 V AC: xB5/xB6

Motor protection

Overload protection ✓ Thermal, range 1:1.3 ✓ Solid-state, wide range 1:10

Overload warning -- Only tripping ✓

Short-circuit protection ✓ Motor starter protector ✓

Full motor protection --

Motor protection response in case of overload Thermal motor model response -- ✓ Parameterizable: disconnection without restart, disconnection with restart, warning

Automatic reset --

Temperature sensor --

Emergency start function -- (✓ with Control Unit 3RK1 903-0CG00) ✓

✓ Function is available

-- Function is not available

¹⁾ The specified device functions apply in full only to the new ..AB4 starters.

²⁾ <http://support.automation.siemens.com/WW/view/en/6008567>



SIMATIC ET 200S
Standard motor starters

SIMATIC ET 200S
High Feature motor starters

Device functions (firmware features)

Device function

Device function	SIMATIC ET 200S Standard motor starters	SIMATIC ET 200S High Feature motor starters
Repair switch	✓ Rocker switch	✓ Motor starter protector
Motor starter protector signaling	✓	✓ Parameterizable
Lower current limit monitoring	--	✓ Parameterizable, increment 3.125%, 18.75 ... 100%
Upper current limit monitoring	--	✓ Parameterizable, increment 3.125%, 50 ... 400%
Residual current detection	--	✓ Parameterizable: warning, disconnection
Stall protection/disconnecting the blocking current	--	✓ Parameterizable
Asymmetry	✓	✓ Parameterizable: warning, disconnection
Load type	--	✓ Parameterizable: 1 and 3-phase
Tripping class	✓ CLASS 10	✓ Parameterizable for DS1e-x, RS1e-x: CLASS 5 (10a), 10, 15, 20 for DSS1e-x: CLASS 5 (10a), 10 (only at 0.3 ... 3 A)
Protection against voltage failure	✓	✓ Parameterizable: activated/deactivated

Local diagnostics functions using LEDs

"C-STAT" switching status	✓ Red/green/yellow LEDs	
"SF" group fault	✓ Red LEDs	
"DEVICE" device status	--	✓ Red/green/yellow LEDs
Auxiliary switches for enabling circuit of the ET 200S – safety technology already integrated (for use up to SIL 3 (IEC 61508) or PL e (DIN EN ISO 13849-1) in combination with infeed contactor)	-- F-Kit is required	✓ Except DSS1e-x (max. SIL 1 or PL b can be achieved)

✓ Function is available

-- Function is not available

ET 200S Standard motor starters
DS1-x, RS1-x

ET 200S High Feature motor starters
DS1e-x, RS1e-x DSS1e-x

Device functions (firmware features)

Control function: soft starter

Control function	ET 200S Standard motor starters DS1-x, RS1-x	ET 200S High Feature motor starters DS1e-x, RS1e-x	ET 200S High Feature motor starters DSS1e-x
Soft start function	--		✓
Bypass function	--		
Starting time	--		✓ Locally adjustable, not through bus 0 ... 20 s
Stopping time	--		✓ Locally adjustable, not through bus 0 ... 20 s
Stopping mode	--		✓ Locally adjustable, not through bus
Start voltage	--		✓ Locally adjustable, not through bus 30 ... 100% of U_g
Stopping voltage	--		✓ Locally adjustable, not through bus
Trace	--		

✓ Function is available

-- Function is not available

SIMATIC ET 200 distributed I/O

ET 200S

Motor starters and safety motor starters

General data

Technical specifications

		ET 200S Standard motor starters DS1-x, RS1-x	ET 200S High Feature motor starters DS1e-x, RS1e-x	DSS1e-x
Mechanical components and environment				
Motor starters for connection to ET 200S, max.¹⁾		42	17	
Mounting dimensions (W x H x D)				
• Direct-on-line starters	mm	45 x (265 + 45) x (120 + 27); (45: PE/N block; 27: auxiliary switch contactor from F-Kit)	65 x (290 + 45) x (150 + 23); (45: PE/N block; 23: control module)	
• Reversing starters	mm	90 x (265 + 45) x (120 + 27); (45: PE/N block; 27: auxiliary switch contactor from F-Kit)	130 x (290 + 45) x (150 + 23); (45: PE/N block; 23: control module)	
Permissible ambient temperature				
• During operation	°C	0 ... +60, from +40 with derating	0 ... +60 For horizontal mounting up to +40	
• During storage	°C	-40 ... +70	-40 ... +70	
• Permissible mounting position	°C	Vertical, horizontal with derating	Vertical, horizontal	
Weight				
• Direct-on-line/reversing starters incl. terminal module	kg	1.0/1.6	1.6/2.2	1
• Direct-on-line/reversing starters incl. terminal block PE/N	kg	1.1/1.8	1.7/2.3	1.1
Vibration resistance acc. to IEC 60068, parts 2-6	g	2		
Shock resistance acc. to IEC 60068, parts 2-27	g/ms	Rectangle 5/11		
Conductor cross-section				
• Solid	mm ²	2 x (1 ... 2.5) ² ; 2 x (2.5 ... 6) ² , according to IEC 60947: max. 1 x 10		
• Finely stranded with end sleeve	mm ²	2 x (1 ... 2.5) ² ; 2 x (2.5 ... 6) ²		
• AWG cables, solid or stranded	AWG	2 x (14 ... 10)		
Degree of protection		IP20, finger-safe (also applies to terminal modules on a dismantled motor starter)		
Mechanical endurance				
• Motor starter protector	Oper- ating cycles	100 000		
• Contactor		30 million	10 million	--
• Contactor with safety function (F-Kit)		10 million	--	--
Electrical data				
Current consumption				
• From auxiliary circuit L+/M (U ₁)	mA	approx. 20	approx. 40	
• From auxiliary circuit A1/A2 (U ₂)	mA	approx. 100	Approx. 1 70 0 (80 ms long), approx. 350 (after 80 ms)	approx. 30
Rated operational current for terminal modules TM-D I_e	A	40	50	
Rated operational voltage U_e	V	400		
Approval DIN VDE 0106, part 101	V	Yes, up to 500		Yes, up to 480
CSA and U_L approval	V	Yes, up to 600		Yes, up to 480
Rated operational current I_e for motor starters				
• AC-1/2/3 at 60 °C				
- At 400 V	A	12	16	3 / 8 / 16
- At 500 V	A	9	11	--
• AC-4 at 60 °C				
- At 400 V	A	4.1	9	--
Rated short-circuit breaking capacity	kA	50 at 400 V		
Power of three-phase motors at 500 V	kW	5.5	7.5	
Utilization categories		AC-1, AC-2, AC-3, AC-4		
Protective separation between main and auxiliary circuits	V	400, according to DIN VDE 0106, part 101		
Positively driven operation of contactor relay (NC)		Yes		
Trip class		CLASS 10	Parameterizable CLASS 5 (10 A), 10, 15, 20	0.3 ... 3 A: CLASS 10/10A, parameterizable; 2.4 ... 8 A: CLASS 10A 2.4 ... 16 A: CLASS 10A
Type of coordination		Up to 1.6 A: 2 Up to 12 A: 1	Up to 16 A: 2	Up to 16 A: 1
Electrical endurance				
• Motor starter protector	h	100 000		
• Contactor		See manual ³⁾		--
Permissible switching frequency with starting time t_A = 0.1 s and relative ON period t_{ED} = 50%	1/h	< 80	See manual ³⁾	
Induction protection		Already installed		

1) Additional limitations: process image, max. design width 2 m.

2) If two different conductor cross-sections are connected to one clamping point, both cross-sections must be in the range specified. If identical cross-sections are used, this restriction does not apply.

3) <http://support.automation.siemens.com/WW/view/en/6008567>

Overview**Functionality of the Standard motor starters**

- For basic functionality see "General data" → "Overview", page 9/148
- Direct-on-line and reversing starters up to 5.5 kW
- Power bus up to 40 A
- With circuit breaker and contactor assembly
- Integrated isolating function of the circuit breaker
- Can be combined with local safety technology for use in safety-related system components with F-Kit and PM-D F modules (see "Accessories" → "Overview", page 9/175)

Device functions (firmware features)

See "General data" → "Overview", page 9/150

Technical specifications

See "General data" → "Technical specifications", page 9/152

Selection and ordering data

Induction motor 4-pole at 400 V AC, standard output <i>P</i> kW	Setting range of the overcurrent release A	Order No.
--	--	-----------

Standard motor starters,
with diagnostics, electromechanical, fuseless,
expandable with brake control module



DS1-x

Direct starter DS1-x

< 0.06	0.14 ... 0.20	3RK1 301-0BB00-0AA2
0.06	0.18 ... 0.25	3RK1 301-0CB00-0AA2
0.09	0.22 ... 0.32	3RK1 301-0DB00-0AA2
0.10	0.28 ... 0.40	3RK1 301-0EB00-0AA2
0.12	0.35 ... 0.50	3RK1 301-0FB00-0AA2
0.18	0.45 ... 0.63	3RK1 301-0GB00-0AA2
0.21	0.55 ... 0.80	3RK1 301-0HB00-0AA2
0.25	0.70 ... 1.00	3RK1 301-0JB00-0AA2
0.37	0.90 ... 1.25	3RK1 301-0KB00-0AA2
0.55	1.1 ... 1.6	3RK1 301-1AB00-0AA2
0.75	1.4 ... 2.0	3RK1 301-1BB00-0AA2
0.90	1.8 ... 2.5	3RK1 301-1CB00-0AA2
1.1	2.2 ... 3.2	3RK1 301-1DB00-0AA2
1.5	2.8 ... 4.0	3RK1 301-1EB00-0AA2
1.9	3.5 ... 5.0	3RK1 301-1FB00-0AA2
2.2	4.5 ... 6.3	3RK1 301-1GB00-0AA2
3.0	5.5 ... 8.0	3RK1 301-1HB00-0AA2
4.0	7 ... 10	3RK1 301-1JB00-0AA2
5.5	9 ... 12	3RK1 301-1KB00-0AA2



RS1-x

RS1-x reversing starters

< 0.06	0.14 ... 0.20	3RK1 301-0BB00-1AA2
0.06	0.18 ... 0.25	3RK1 301-0CB00-1AA2
0.09	0.22 ... 0.32	3RK1 301-0DB00-1AA2
0.10	0.28 ... 0.40	3RK1 301-0EB00-1AA2
0.12	0.35 ... 0.50	3RK1 301-0FB00-1AA2
0.18	0.45 ... 0.63	3RK1 301-0GB00-1AA2
0.21	0.55 ... 0.80	3RK1 301-0HB00-1AA2
0.25	0.70 ... 1.00	3RK1 301-0JB00-1AA2
0.37	0.90 ... 1.25	3RK1 301-0KB00-1AA2
0.55	1.1 ... 1.6	3RK1 301-1AB00-1AA2
0.75	1.4 ... 2.0	3RK1 301-1BB00-1AA2
0.90	1.8 ... 2.5	3RK1 301-1CB00-1AA2
1.1	2.2 ... 3.2	3RK1 301-1DB00-1AA2
1.5	2.8 ... 4.0	3RK1 301-1EB00-1AA2
1.9	3.5 ... 5.0	3RK1 301-1FB00-1AA2
2.2	4.5 ... 6.3	3RK1 301-1GB00-1AA2
3.0	5.5 ... 8.0	3RK1 301-1HB00-1AA2
4.0	7 ... 10	3RK1 301-1JB00-1AA2
5.5	9 ... 12	3RK1 301-1KB00-1AA2

SIMATIC ET 200 distributed I/O

ET 200S

Motor starters and safety motor starters Standard terminal modules

Overview

TM-DS, TM-RS terminal modules

More information see also "General data" → "Overview" → from the section "Power supply through terminal modules", page 9/148.

- "-S32" version with feeder cable connection: 2 x 3 x 10 mm² screw terminals for power bus and motor feeder
- "-S31" version without feeder cable connection: 1 x 3 x 10 mm² screw terminals for motor feeder
- Optionally expandable with PE/N modules (see "Accessories", page 9/178)
- Applies only to Standard motor starters: For applications with high motor currents (> 6.3 A) or high ambient temperatures (> 40 °C), use of the DM-V15 distance module is recommended between two DS1-x motor starters (see "Accessories", page 9/176).

Technical specifications

TM-DS45 and TM-DS65/TM-FDS65 terminal modules

		TM-DS45	TM-DS65/TM-FDS65
Dimensions			
• Mounting dimensions (W x H x D)	mm	45 x 264 x 100	65 x 290 x 100
• Height with PE/N terminal block	mm	306	332
• Depth with motor starter	mm	127	150
• Depth with motor starter and F-Kit (safety technology)	mm	152	--
• Depth with motor starter and 2DI control module	mm	--	173
Rated voltages, currents and frequencies for the power bus			
• Rated insulation voltage U_i	V	690	
• Rated operational voltage U_o	V AC	500	
• Rated impulse withstand voltage U_{imp}	kV	6	
• Rated operational current I_o	A	40	50
• Rated frequency	Hz	50/60	
Conductor cross-sections			
• Solid	mm ²	2 x (1 ... 2.5) ¹⁾ or 2 x (2.5 ... 6) ¹⁾	
• Finely stranded with end sleeve	mm ²	1 x 10 or 2 x (1 ... 2.5) ¹⁾ or 2 x (2.5 ... 6) ¹⁾ according to IEC 60947	
• AWG cables, solid or stranded	AWG	2 x (14 ... 10)	
• With additional three-phase feeder terminal if required			
- Solid or stranded	mm ²	1 x 2.5 ... 25	
- Finely stranded with end sleeve	mm ²	1 x 2.5 ... 25	
- AWG cables, solid or stranded	AWG	1 x 12 ... 4	
Wiring			
• Required tool		Standard screwdriver size 2 and Pozidriv 2	
• Tightening torque	Nm	2.0 ... 2.5	

¹⁾ If two different conductor cross-sections are connected to one clamping point, both cross-sections must be in the range specified. If identical cross-sections are used, this restriction does not apply.

TM-RS90 and TM-RS130/TM-FRS130 terminal modules



		TM-RS90	TM-RS130/TM-FRS130
Dimensions			
• Mounting dimensions (W x H x D)	mm	90 x 264 x 100	130 x 290 x 100
• Height with PE/N	mm	306	332
• Depth with motor starter	mm	127	150
• Depth with motor starter and F-Kit (safety technology)	mm	152	--
• Depth with motor starter and 2DI control module	mm	--	173
Rated voltages, currents and frequencies for the power bus			
• Rated insulation voltage U_i	V	690	
• Rated operational voltage U_o	V AC	500	
• Rated impulse withstand voltage U_{imp}	kV	6	
• Rated operational current I_o	A	40	50
• Rated frequency	Hz	50/60	

Motor starters and safety motor starters Standard terminal modules

	TM-RS90	TM-RS130/TM-FRS130
Conductor cross-sections		
• Solid	mm ²	2 x (1 ... 2.5) ¹⁾ or 2 x (2.5 ... 6) ¹⁾
• Finely stranded with end sleeve	mm ²	1 x 10 or 2 x (1 ... 2.5) ¹⁾ or 2 x (2.5 ... 6) ¹⁾ according to IEC 60947
• AWG cables, solid or stranded	AWG	2 x (14 ... 10)
• With additional three-phase feeder terminal if required		
- Solid or stranded	mm ²	1 x 2.5 ... 25
- Finely stranded with end sleeve	mm ²	1 x 2.5 ... 25
- AWG cables, solid or stranded	AWG	1 x 12 ... 4
Wiring		
• Required tool		Standard screwdriver size 2 and Pozidriv 2
• Tightening torque	Nm	2.0 ... 2.5

¹⁾ If two different conductor cross-sections are connected to one clamping point, both cross-sections must be in the range specified. If identical cross-sections are used, this restriction does not apply.

Selection and ordering data

Version	Order No.
Terminal modules for Standard motor starters	
 3RK1 903-0AB00	TM-DS45-S32 for DS1-x direct-on-line starters with incoming power bus connection including three caps for terminating the power bus 3RK1 903-0AB00
 3RK1 903-0AB10	TM-DS45-S31 for DS1-x direct-on-line starters without incoming power bus connection 3RK1 903-0AB10
 3RK1 903-0AC00	TM-RS90-S32 for RS1-x reversing starters with incoming power bus connection including three caps for terminating the power bus 3RK1 903-0AC00
	TM-RS90-S31 for RS1-x reversing starters without incoming power bus connection 3RK1 903-0AC10

SIMATIC ET 200 distributed I/O

ET 200S

Motor starters and safety motor starters High Feature motor starters

Overview

Functionality of the High Feature motor starters

- For basic functionality see "General data" → "Overview", page 9/148.
- Direct-on-line, reversing, or soft starter up to 7.5 kW
- With wide range in 3 setting ranges, with 0.3 to 3 A, 2.4 up to 8 A, 2.4 to 16 A available
- With combination of starter circuit breaker, electronic overload protection (parameterizable), and contactor or soft starter
- Power bus up to 50 A
- Upper and lower current limits for plant and process monitoring
- Motor stall protection, zero current detection and asymmetry detection integrated
- The current motor current is measured and transmitted for diagnostics in the cycle process image
- Control of the motor starter from the control system and extensive diagnostics status via the cyclic process image
- Optional digital inputs available in the cyclic process image and flexibly assignable with functions for adaptation to all applications
- Integrated isolating function using starter circuit breakers
- Detection of the switching state of the starter circuit breaker via auxiliary switches and of the contactor via current evaluation
- Local safety engineering possible (without F-Kit in the case of the HF starter, because the function of the Failsafe Kit is already integrated)
- Front-mounting 2DI LC COM control module for another 2 parameterizable digital inputs
- Optional "Motor Starter ES" software for easy commissioning and diagnostics (see Catalog IC 10, Chapter "Parametrization, Configuration and Visualization with SIRIUS")
- PROFinergy capable
- Supplying the motor current in PROFinergy format and shutting down in dead times
- Support of all DPV1 acyclic services on PROFIBUS and PROFINET
 - Changing parameters, such rated operational current, during operation
 - Reading and writing acyclic data for exact diagnostics of the unit or process, and for analysis of the plant status

Selective protection concept for ET 200S High Feature motor starters

As the result of the selective protection concept (separate tripping of short-circuit and overload) with electronic overload evaluation, additional advantages are realized on the High Feature motor starters – advantages which soon make themselves positively felt particularly in manufacturing processes with high plant standstill costs:

- Only two versions up to 7.5 kW – hence little order variance and stock keeping
- All settings can be parameterized by bus – hence full TIA capability
- Separate signaling of overload and short-circuit – enables selective diagnostics
- Overload can be acknowledged by remote reset – ideal for highly automated plants
- Current asymmetry monitoring – complete monitoring of the motor
- Stall protection – complete monitoring of the motor
- Emergency start function in case of overload – operation is possible in an emergency

- Current value transmission via bus – monitoring of the application
- Current limit monitoring
- Trip class can be parameterized – overload trip can be adapted to the application
- Type of coordination "2" – still functional after short-circuit with magnitude of 50 kA
- Very high contact endurance



ET 200S High Feature motor starters: DS1e-x direct-on-line starters



ET 200S High Feature motor starters: DSS1e-x direct soft starters



ET 200S High Feature motor starters: RS1e-x reversing starters

Motor starters and safety motor starters
High Feature motor startersPROFenergy for ET 200S High Feature motor starters¹⁾

Increasing energy prices, far-reaching ecological problems worldwide and the threat of climate change make it necessary for you to be more conscious about your use of energy.

Active and effective energy management is possible with PROFenergy.

PROFenergy is a manufacturer-independent profile on PROFINET, which can be used by all manufacturers, has been standardized by PNO¹⁾ and supports shutting down electrical devices during dead times and reading out measured values.

The ET 200S HF motor starter supplies the motor current in PROFenergy format and switches off during dead times.

Support of all acyclic services on PROFIBUS and PROFINET

Thanks to the acyclic services, the ET 200S HF motor starters now also offer a host of diagnostics data via data records. There are new extensive options for reading out data from the motor starter for monitoring devices, systems or processes. The motor starter is equipped internally with three logbooks for device faults, motor starter trips and events, which are issued with a time stamp. These logbooks can be read out of the motor starter on demand at any time and provide the plant operator with plenty of information about the state of his plant and process which he can use to carry out improvements.

With the slave pointer and statistical data functions it is possible to read out, for example, the maximum internal current values or the number of motor starter connection operations. This allows deviations in the process to be monitored, but also optimum initial commissioning to take place.

Statistical data or measured values make plant monitoring easy for the user.

The device diagnostics data record contains all statuses on the motor starter for the device state, its configuration and the communication status and serves for central device and plant monitoring.

The installation and maintenance functions (I&M) are used on one hand to store information (I&M) on modules employed in the motor starter, and on the other, to store data (I&M) that can be specified during configuration, such as location designations. I&M functions are used to troubleshoot faults, to localize changes in plant hardware, or to check the system configuration.

Supported data records:

- DS 0 S7-V1 system diagnostics (S7 diagnostics alarm)
- DS 72, 73, 75 logbooks, device faults, trips, events
- DS 92 device diagnostics
- DS 93 command
- DS 94 measured values
- DS 95 statistics
- DS 96 slave pointer
- DS 100 device identification
- DS 131 device parameters
- DS 134 maintenance
- DS 165 comment
- DS 226 PROFenergy technology function
- DS 231 I&M 0 (= device identification)
- DS 232 I&M 1 (= equipment identifier)
- DS 233 I&M 2 (= installation)
- DS 234 I&M 3 (= description)

Device functions (firmware features)

See "General data" → "Overview", page 9/150

¹⁾ In the PNO (PROFIBUS Nutzerorganisation e. V. - PROFIBUS User Organization), manufacturers and users have come together to agree on the standardized communication technologies PROFIBUS and PROFINET.

Technical specifications

See "General data" → "Technical specifications", page 9/152

Selection and ordering data**High Feature motor starters in fully innovated design ("-.AB4 starters")¹⁾**

Setting range of the A	Order No.
High Feature motor starters, with diagnostics, electronic overload protection, fuseless, expandable with brake control module	
DS1e-x direct-on-line starters	
0.3 ... 3	3RK1 301-0AB10-0AB4
2.4 ... 8	3RK1 301-0BB10-0AB4
2.4 ... 16	3RK1 301-0CB10-0AB4
RS1e-x reversing starters	
0.3 ... 3	3RK1 301-0AB10-1AB4
2.4 ... 8	3RK1 301-0BB10-1AB4
2.4 ... 16	3RK1 301-0CB10-1AB4
DSS1e-x direct soft starters	
0.3 ... 3	3RK1 301-0AB20-0AB4
2.4 ... 8	3RK1 301-0BB20-0AB4
2.4 ... 16	3RK1 301-0CB20-0AB4



DS1e-x

¹⁾ When a device is replaced, the innovated motor starter will behave like the not yet innovated motor starter ("-.AA4 starter"), i.e. it will run in DPV0 mode.

SIMATIC ET 200 distributed I/O

ET 200S

Motor starters and safety motor starters High Feature terminal modules

Overview

TM-DS, TM-RS terminal modules

More information see also "General data" → "Overview" → from the section "Power supply through terminal modules", page 9/148.

- "-S32" version with incoming connection: 2 x 3 x 10 mm² screw terminals for power bus and motor feeder
- "-S31" version without incoming connection: 1 x 3 x 10 mm² screw terminals for motor feeder
- Optionally expandable with PE/N modules (see "Accessories", page 9/178)

Technical specifications

See "Standard terminal modules" → "Technical specifications", page 9/154.

Selection and ordering data

Version	Order No.
Terminal modules for High Feature motor starters	
 TM-DS65-S32 for DS1e-x and DSS1e-x direct-on-line starters with incoming power bus connection including three caps for terminating the power bus	3RK1 903-0AK00
TM-DS65-S31 for DS1e-x and DSS1e-x direct-on-line starters without incoming power bus connection	3RK1 903-0AK10
TM-RS130-S32 for RS1e-x reversing starters with incoming power bus connection including three caps for terminating the power bus	3RK1 903-0AL00
TM-RS130-S31 for RS1e-x reversing starters Without incoming power bus connection	3RK1 903-0AL10

3RK1 903-0AK00

Overview

- Disconnection of a complete group of motor starters is possible without any additional outlay (PL b according to ISO 13849-1 or SIL 1 according to IEC 62061)
- PM-D power modules are plugged onto the TM-P15 terminal modules. (A PM-D power module must be followed by at least one motor starter or one frequency converter.)

PM-D power modules are used for monitoring the two 24 V DC auxiliary voltages for the group of motor starters following on the right or for supplying power to the group of frequency converters following on the right. The voltage is fed in through TM-D terminal modules to the self-assembling potential bars.

A voltage failure is signaled through PROFIBUS diagnostics to the higher-level master. Additional LEDs inform locally about the status of the auxiliary voltages.

The separation of auxiliary voltages for signal checkback and power section actuation enables the entire group to be shut down while maintaining the diagnostics capability.

Technical specifications

		Power module PM-D 3RK1 903-0BA00
Rated control supply voltage U_s up to V 60 °C		20.4 ... 28
Rated operational current I_o		
• Recommended short-circuit protection	A	10
• Fuse	A	10
• Circuit breaker	A	10, tripping characteristic B
Current consumption from backplane bus	mA	≤ 10
Supply of		
• Motor starters		Yes
• Frequency converters		Yes
• Motor starters for safety technology		No
• Electronic modules		No
• Ex(i) modules		No
Alarms		None
Diagnostics functions		Yes
• System/device fault		Red LED "SF"
• Monitoring of the power supply for the electronics U_1		Green "PWR" LED
• Monitoring of the supply voltage for contactors U_2		Green "CON" LED
• Diagnostics information can be read out		Yes
Conductor cross-sections		
• Flexible with end sleeve	mm ²	1.5
• rigid	mm ²	2.5
Mounting dimensions (W x H x D)	mm	15 x 195.5 x 117.5

Selection and ordering data

Version	Order No.
Power module  PM-D power modules for 24 V DC with diagnostics	3RK1 903-0BA00

3RK1 903-0BA00

SIMATIC ET 200 distributed I/O

ET 200S

Motor starters and safety motor starters Terminal module for power module

Overview

Terminal module for power module

For supplying load and sensor voltage to the self-assembling voltage buses of the Standard motor starters, High Feature motor starters, and frequency converters. Power modules for voltage monitoring are plugged onto TM-P modules.

TM-P modules can be used any number of times within the ET 200S. A power module must always be plugged upstream from the first motor starter/frequency converter.

Selection and ordering data

Version	Order No.
Terminal module for power module	
 <p>TM-P15 S27-01 terminal modules for PM-D power module</p> <p>3RK1 903-0AA00</p>	<p>3RK1 903-0AA00</p>

Overview



ET 200S Failsafe motor starters: F-DS1e-x direct-on-line starters

The Failsafe motor starter has been developed on the basis of the High Feature motor starter (.-AA4 starter). It differs in that, in addition to a motor starter protector and contactor assembly, a safe electronic evaluation circuit is installed for error detection purposes which makes the motor starter fail-safe.

If the contactor to be switched fails in an EMERGENCY STOP case, the evaluation electronics detects a fault and opens the motor starter protector in the motor starter through a shunt release in a fail-safe manner. The second redundant shutdown component is therefore no longer a main contactor, as is generally the case, but the motor starter protector installed in the motor.

All functions of the High Feature starter are already integrated.

The new Failsafe motor starters are characterized by easy, space-saving assembly as well as minimal wiring outlay. Like the High Feature starters, the Failsafe motor starters have a switching capacity of up to 7.5 kW (16 A), which is achieved with just two motor starter versions. Another important feature is the high

availability due to the high short-circuit strength (type of coordination "2").

Application

The Failsafe motor starter is predestined for use in combination with PROFIsafe (see connection diagram "ET 200S Safety motor starter Solution PROFIsafe with Failsafe motor starters", page 9/169). Another field of application is in combination with ASIsafe or safety relays (see Example 2, page 9/167).

High degree of flexibility with safety technology

Solution PROFIsafe with PM-D F PROFIsafe

In EMERGENCY STOP applications, the Failsafe motor starters are selectively switched off through the upstream PM-D F PROFIsafe safety module. For each safety module, six switch-off groups can be formed. In the first delivery stage, the fail-safe freely-programmable logic of the SIMATIC controller is used to interface with the relevant fail-safe sensor technology. The interface between PROFIsafe and installations that use conventional safety technologies is implemented through the F-CM fail-safe contact multiplier with four floating contacts.

Solution local with PM-D FX1

Failsafe motor starter with safety relay (version 1) or ASIsafe (version 2, see example 2, page 9/167): Safety-related signals can be input to ET 200S through a PM-D F X1 infeed terminal module via the enabling circuits of the AS-i Safety Monitor or the safety relay to control the Failsafe motor starters which then selectively switch off the downstream motors.

Benefits

Advantages over conventional safety technology:

- Significant savings in components (less hardware)
- Less mounting and installation work
- Motor starters are fail-safe and offer high availability

Technical specifications

F-DS1e-x direct-on-line starters/F-RS1e-x reversing starters

		F-DS1e-x direct-on-line starters	F-RS1e-x reversing starters
Dimensions			
Dimensions (W x H x D)	mm	65 x 290 x 150 (incl. terminal module)	130 x 290 x 150 (incl. terminal module)
Height with PE/N module	mm	332	
Depth with 2DI control module (not safe)	mm	173	
Module-specific data			
Type of coordination		Type 2 up to $I_{\sigma} \leq 16$ A at 400 V	
Internal power supply		U1 (from PM-D F / PM-D X1)	
Maximum achievable safety class		SIL 3 Tripping class 6 (AK6) PL e	
• According to IEC 62061			
• According to DIN VDE 0801			
• According to ISO 13849-1			
Safety characteristics			
Low demand	PFD _{AVG} (10a)		
• Test interval 3 months		3.5 x 10 ⁻⁵	
• Test interval 6 months		8.0 x 10 ⁻⁵	
High demand/continuous mode	PFH		
• Test interval 3 months	1/h	8.1 x 10 ⁻¹⁰	
• Test interval 6 months	1/h	1.8 x 10 ⁻⁹	
Proof-test interval	Years	10	

SIMATIC ET 200 distributed I/O

ET 200S

Motor starters and safety motor starters ET 200S Failsafe motor starters

		F-DS1e-x direct-on-line starters	F-RS1e-x reversing starters
Voltages, currents, potentials			
Switching capacity	A A A	Up to 7.5 kW at 400 V AC in three setting ranges • 0.3 ... 3 • 2.4 ... 8 • 2.4 ... 16	
Status, alarms, diagnostics			
Status display		SF, DEVICE and C-STAT, SG1 ... SG6	
Diagnostics functions		Red LED (SF) possible	
• Group fault display			
• Diagnostics information can be read out			
Control circuit			
Rated operational voltage for electronics U_1	V DC	24 (20.4 ... 28.8)	24 (21.6 ... 26.4)
Reverse polarity protection for electronics U_1		Yes	
Rated operational voltage for contactor U_2	V DC	24 (20.4 ... 28.8)	
Reverse polarity protection for contactor U_2		Yes	
Current consumption			
• From electronics supply U_1	mA	approx. 40	approx. 100
• From contactor supply U_2			
- Pick-up	A	1.7 (for 80 ms)	--
- Hold	mA	max. 350	--
• From SG1 to 6			
- Pick-up	mA	250 (for 200 ms)	
- Hold	mA	max. 55	
• Test function of the shunt release/starter circuit breaker (50 ms) from U_1	A	approx. 1.5	
• From the backplane bus	mA	approx. 20	
Main circuit			
Rated operational voltage U_e			
• According to DIN VDE 0106, part 1014, IEC 60947-1, EN 60947-1	V AC	500	
• Protective separation between main and auxiliary circuits	V	400	
• UL, CSA	V AC	600	
Rated insulation voltage U_i	V AC	500	
Rated impulse withstand voltage U_{imp}	kV	6	
Rated frequency	Hz	50/60	

9

Selection and ordering data

	Setting range of the overcurrent release	Order No.
A		
ET 200S Failsafe motor starters		
	F-DS1e-x direct-on-line starters Failsafe direct-on-line starters up to 7.5 kW at 400 V AC Mechanically switching Solid-state UE protection	
	• 0.3 ... 3	3RK1 301-0AB13-0AA4
	• 2.4 ... 8	3RK1 301-0BB13-0AA4
	• 2.4 ... 16	3RK1 301-0CB13-0AA4
	F-RS1e-x reversing starter Failsafe reversing starters up to 7.5 kW at 400 V AC Mechanically switching Solid-state UE protection, fuseless	
	• 0.3 ... 3	3RK1 301-0AB13-1AA4
• 2.4 ... 8	3RK1 301-0BB13-1AA4	
• 2.4 ... 16	3RK1 301-0CB13-1AA4	

F-DS1e-x
direct-on-line starters

Selection and ordering data

Version	Order No.
Terminal modules for Failsafe motor starters	
 <p>TM-FDS65-S32-01/S31-01 terminal module for F-DS1e-x direct-on-line starters with coding</p> <ul style="list-style-type: none"> • With incoming power bus connection (TM-FDS65-S32-01) • Without incoming power bus connection (TM-FDS65-S31-01) 	<p>3RK1 903-3AC00</p> <p>3RK1 903-3AC10</p>
<p>TM-FRS130-S32-01/S31-01 terminal module for F-RS1e-x reversing starter with coding</p> <ul style="list-style-type: none"> • With incoming power bus connection (TM-FRS130-S32-01) • Without incoming power bus connection (TM-FRS130-S31-01) 	<p>3RK1 903-3AD00</p> <p>3RK1 903-3AD10</p>

3RK1 903-3AC00

SIMATIC ET 200 distributed I/O

ET 200S

Motor starters and safety motor starters Safety local and PROFIsafe modules

Overview

ET 200S Safety motor starter Solutions local/PROFIsafe

The ET 200S Safety motor starter Solutions are preferred in all production and process automation fields in which the increase of plant availability and flexibility plays a key role.

- ET 200S Safety motor starter Solution local is preferred from the safety technology point of view for locally restricted safety applications. These motor starters are not dependent on a safe control system.
- ET 200S Safety motor starter Solution PROFIsafe is often found by contrast in networked safety applications of the more complex type. In this case, a safe control system is used with the PROFINET or PROFIBUS bus systems with the PROFIsafe profile.

The ET 200S Safety motor starter Solutions comprise:

- Safety modules ([page 9/165](#))
- Standard motor starters ([page 9/153](#))
- High Feature motor starters ([page 9/156](#))
- Failsafe motor starters ([page 9/161](#))

With the ET 200S Safety motor starter Solution local, there is no complicated and hence cost-intensive configuring and wiring

ET 200S Safety motor starter Solution local

compared to conventional safety technology. The ET 200S Safety motor starter Solution local is designed for PI e according to ISO 13849-1 or SIL 3 IEC 62061.

They enable the use of safety-oriented direct-on-line starters or reversing starters in the SIMATIC ET 200S distributed I/O system on PROFINET or PROFIBUS. The bit-modular architecture of the system permits optimum mapping of machine or plant applications.

Within an ET 200S station, the Safety motor starter Solution local can also be combined with Standard motor starters or High Feature motor starters without safety functions up to max. 4 kW up to PI d according to ISO 13849-1 or SIL 2 according to IEC 62061.

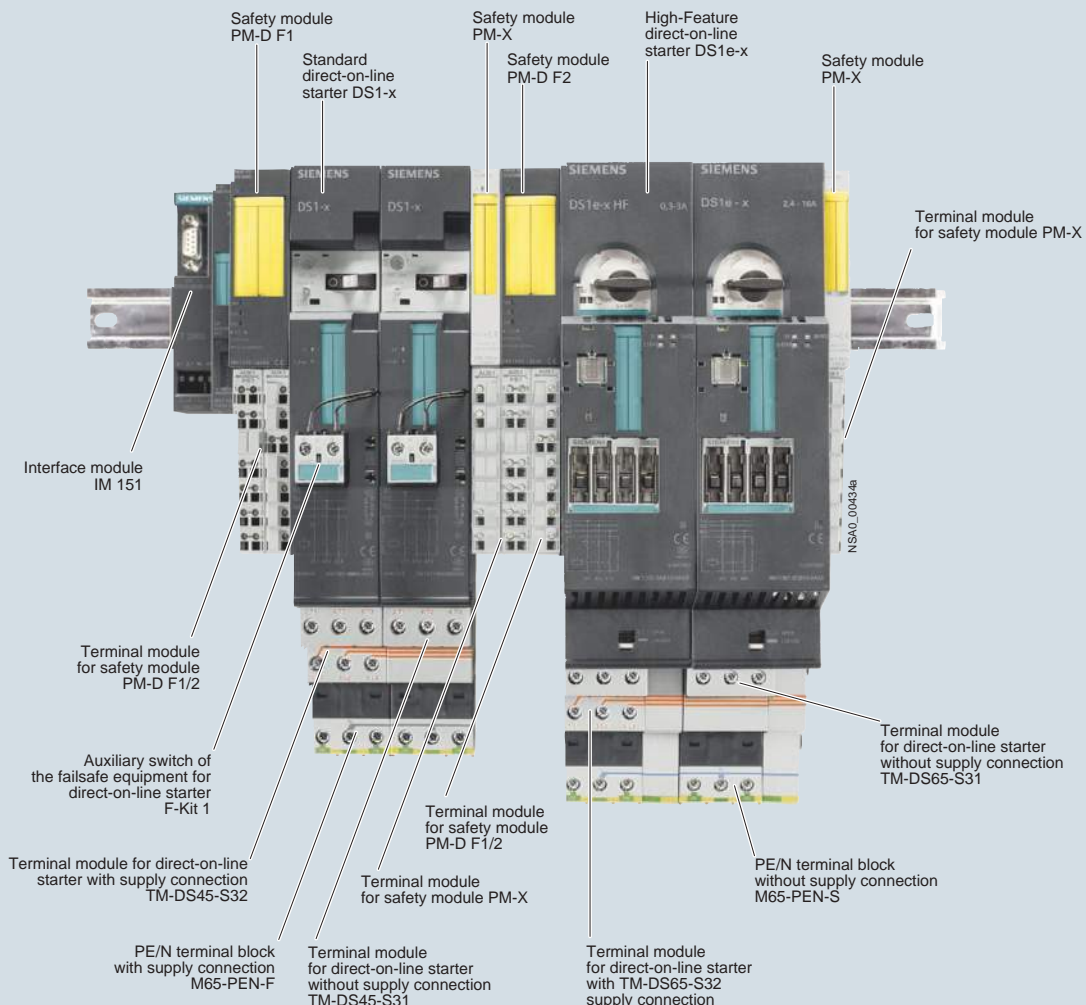

Interplay of ET 200S Safety motor starter Solution local components

Components for ET 200S Safety motor starter Solution local

The ET 200S Safety motor starter Solutions local comprise:

Version 1 (see example 1, page 9/167):

- Safety modules PMD F1 ... 5
- PM-X module
- Standard motor starter or High Feature motor starter

Version 2 (see example 2, page 9/167):

- PM-D FX1 safety module
- Failsafe motor starter

Functionality of the ET 200S Safety motor starter Solution local

- For using Standard, High Feature or Failsafe motor starters in plants with safety category SIL 1 (according to IEC 62061) or PL c to PL e (according to ISO 13849-1)
- Can also be used in combination with external safety relays
- Can also be used to activate external safety systems
- No complex wiring for conventional safety technology
- Safety module available for function-monitored and automatic starting
- Safety module available for stop categories 0 and 1
- Safety module for monitoring the auxiliary voltages for motor starters
- Safety modules can be plugged into the TM-PF30 terminal modules.

With Safety motor starter Solution local, the highest safety category can be reached according to ISO 13849-1 and IEC 62061. They can thus be used for evaluation of EMERGENCY STOP circuits or for monitoring protective doors and also for time-delayed disconnections. With the contact multiplier, the safety-relevant signals can also be made available to external systems.

All standard safety applications can be covered through combination of different TM-PF30 terminal modules. Needless to say, ET 200S motor starters can also be used in conjunction with external safety relays or with ASIsafe.

With the Safety motor starter Solution local, up to 80% of wiring is saved compared to conventional safety systems with local safety applications.

With the Safety motor starter Solution local, it is easy to configure several safety circuits. The safety sensors are connected directly and locally to the safety modules. These safety modules perform the work of the otherwise obligatory safety relays and safely shut down the downstream motor starters in accordance with the function selected. The crosslinks required for this are already integrated in the system and need no additional wiring. All signals from the safety modules are automatically relayed as diagnostic signals, e.g. in the event of crossover in the EMERGENCY-STOP circuit.

The safety module evaluates the signal state of the connected safety sensors and, using the integrated safety relays, shuts down the group(s) of downstream motor starters. The shutdown function is monitored by the module, and the auxiliary voltages likewise.

Safety-related system signals, e.g. due to an actuated EMERGENCY STOP switch or a missing auxiliary voltage, are automatically generated and notified to the interface module. The latter assigns an unambiguous ID to the fault. Using the PROFIBUS DP diagnostics block, faults of this type can be identified and localized without a great deal of programming work.

PM-D F1/F2/F3/F4/F5 safety modules

- PM-D F1/F2/F3/F4 safety modules monitor auxiliary voltages and contain the complete functionality of a safety relay:
 - PM-D F1: For evaluation of EMERGENCY STOP circuits with the function "Monitored start"
 - PM-D F2: For monitoring of protective doors with the function "Automatic start"
 - PM-D F3: Expansion to PM-D F1/F2 for time-delayed tripping
 - PM-D F4: For expanding safety circuits with other ET 200S motor starters, e.g. in a different tier
 - PM-D F5: Transmits the status from PM-D F1 ... 4 through four floating enabling circuits to external safety devices (contact multipliers)
- The PM-D F1 and PM-D F2 modules can be combined with the PM-D F3 or PM-D F4 modules.
- A PM-D F5 can be positioned at any point between a PM-D F1 ... 4 and a PM-X¹⁾.
- Safety modules monitor the U1 and U2 auxiliary voltages. A voltage failure is relayed as a diagnostic signal over the bus.
 - No additional PM-D safety module is required when the safety modules are used.
 - Each safety circuit, beginning with a PM-D F1 ... 4, must be terminated with one PM-X each¹⁾.

¹⁾ See "Accessories for Safety local modules" 9/179.



PM-D F1 safety module

PM-D FX1 safety module

The PM-D FX1 safety module is used for feeding in 1 to 6 switch-off groups. The infeed voltage can be switched using 1 to 6 external safety shutdown devices (either ASIsafe monitors or 3TK28 safety relays). This safety module is used in applications with external safety shutdown devices where there is a need for the fully selective safety shutdown of Failsafe motor starters/frequency converters (see example 2, page 9/167).

Terminal modules for (TM-PF30) safety module

For supplying load and sensor voltage to the potential bars of the motor starters, and for connection of the 2-channel sensor circuit (e.g. EMERGENCY STOP pushbutton) and a RESET button. Different terminal modules are available for configuring separate safety circuits or for cascading safety circuits, and for applications with time-delayed disconnection (see page 9/173).

SIMATIC ET 200 distributed I/O

ET 200S

Motor starters and safety motor starters Safety local and PROFIsafe modules

Terminal module (TM-X)

For connection of an external infeed contactor (2nd shutdown possibility), with terminals for contactor coil and feedback contact, a safety-related motor starter is always required at the end of a group.

Failsafe Kit

The Failsafe Kit (F-Kit) must be added to each Standard motor starter in a safety segment in order to monitor the switching function.

F-Kit 1 supplements the DS1-x direct-on-line starter, and F-Kit 2 supplements the RS1-x reversing starter.

The F-Kits comprise

- Contact supports for the terminal modules
- One or two auxiliary switch blocks for the contactor/contactors of the motor starter
- Connecting cables

High Feature motor starters and their terminal modules come as standard with the functionality of the F-Kits integrated.

Components required for applications with safety requirement

Components required	Maximum achievable safety integrity according to ISO 13849-1 or IEC 62061				
	ISO 13849-1	PL b/c	PL c	PL d ¹⁾	PL d / PL e ¹⁾
	IEC 62061	SIL 1	SIL 1	SIL 2	SIL 3
PM-D		✓	--	--	--
PM-D F1/-F2/-F4		--	✓	✓	✓
PM-D F3		--	✓	✓	--
F-Kit 1/F-Kit 2		--	✓ ²⁾	✓ ²⁾	✓ ²⁾
PM-X		--	✓	✓	✓
PM-D FX1		--	✓	✓	✓

✓ Required

-- Not required

¹⁾ An external infeed contactor is required in the main circuit (2-channel capability).

²⁾ F-Kit is only required for the Standard motor starter; it is already integrated in the High Feature motor starter.

Possible combinations of safety and terminal modules

Terminal module	PM-D F1	PM-D F2	PM-D F3	PM-D F4	PM-D F5	PM-X	PM-DFX1	FCM
TM-PF30 S47-B0	✓	✓	--	--	--	--	--	--
TM-PF30 S47-B1	✓	✓	--	--	--	--	--	--
TM-PF30 S47-C0	--	--	✓	✓	--	--	--	--
TM-PF30 S47-C1	--	--	✓	✓	--	--	--	--
TM-PF30 S47-D0	--	--	--	--	✓	--	--	--
TM-X15 S27-01	--	--	--	--	--	✓	--	--
TM-PFX30 S47-G0	--	--	--	--	--	--	✓	--
TM-PFX30 S47-G1	--	--	--	--	--	--	✓	--
TM-FCM30 S47	--	--	--	--	--	--	--	✓

✓ Available

-- Not available

Examples

The diverse possible uses of the Safety motor starter Solution local are presented in the manual SIMATIC ET 200S Motor Starters in the context of typical sample applications.

Safety functional examples for easy, quick and low-cost implementations of applications with Safety motor starters Solution local are available on the Internet:

More information can be found on the Internet at:
www.siemens.com/ET200S-Motorstarter

Example 1:

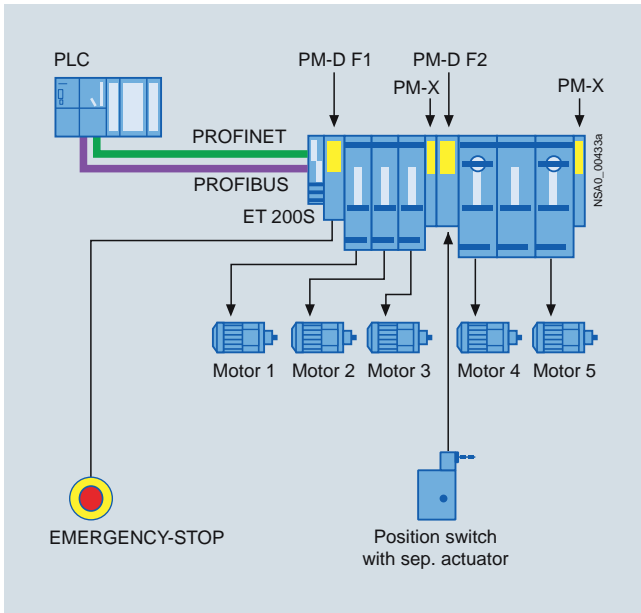

ET 200S Safety motor starter Solution local with 2 safety circuits (= switch-off groups), Standard motor starters, and High Feature motor starters.

Example 2:

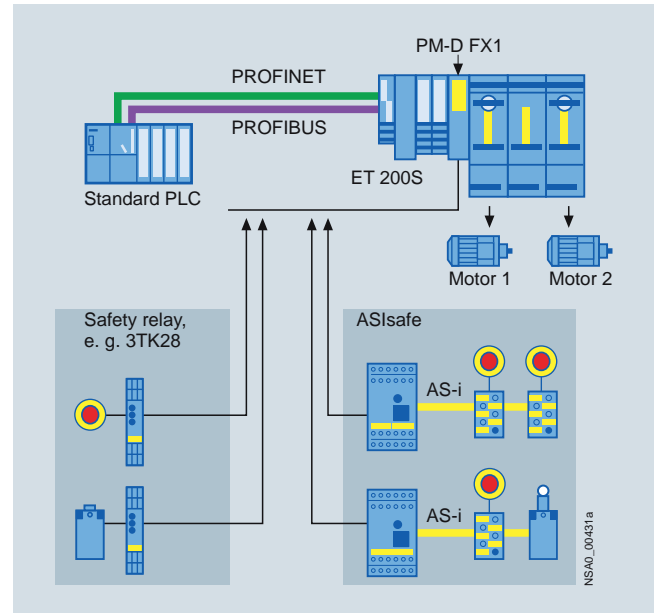

ET 200S Safety motor starter Solution local with 2 external safety assemblies (safety relays or ASIsafe monitors) and with Failsafe motor starters (PM-DFX1 application). 2 of the 6 available safe switch-off groups are used.

Safety-related signals can be input to ET 200S via a PM-DFX1 infeed terminal module by means of the enabling circuits of the ASIsafe monitor or the safety relay to control the Failsafe motor starters which then selectively switch off the downstream motors.

SIMATIC ET 200 distributed I/O

ET 200S

Motor starters and safety motor starters
Safety local and PROFI-safe modules

ET 200S Safety motor starter Solution PROFI-safe

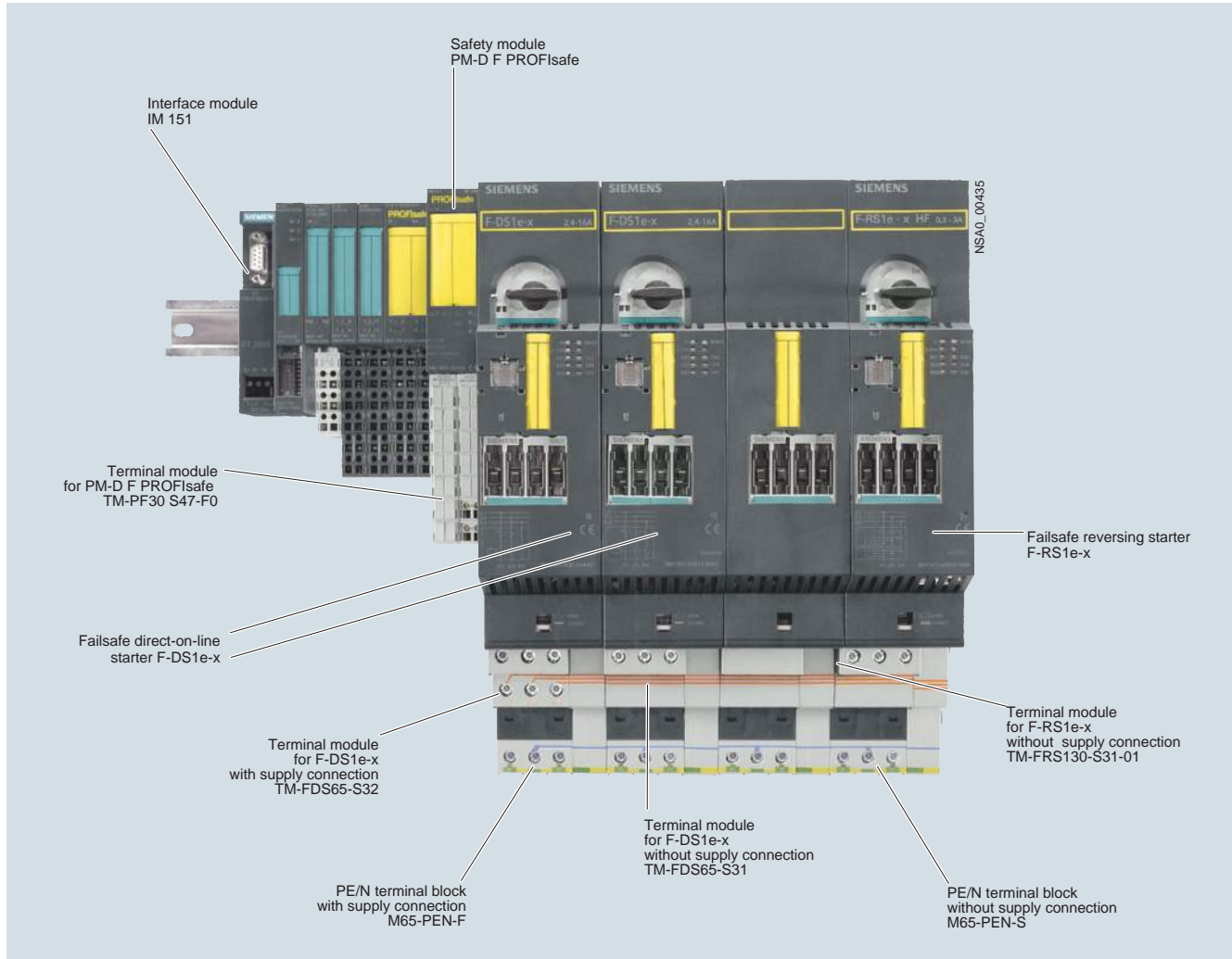

Interplay of ET 200S Safety motor starter Solution PROFI-safe components

Components for ET 200S Safety motor starter Solution PROFI-safe

The ET 200S Safety motor starter Solutions PROFI-safe consist of (see example, page 9/169):

- PMD F PROFI-safe safety modules
- Failsafe motor starter
- Safe control system is used with the bus systems PROFINET or PROFIBUS with the PROFI-safe profile

Functionality of the ET 200S Safety motor starter Solution PROFI-safe

- For using Failsafe motor starters in plants with PL c to PL e according to ISO 13849-1 and SIL 2 and 3 according to IEC 62061. Use with Standard or High Feature motor starters is also possible with certain combinations.
- High flexibility (any assignment of sensors to motor starters using the PLC)
- Full selectivity of disconnection of the Failsafe motor starters
- No complex wiring for conventional safety systems, e.g. no infeed contactors even in the highest safety category
- Can also be used to activate external safety systems through F-CM contact multiplier
- Safety module available for any safety function
- Safety module available for stop categories 0 and 1

- Safety module for monitoring the auxiliary voltages for motor starters
- Safety modules can be plugged into the TM-PF30 terminal modules.

Sensor and actuator assignment are freely configurable within the framework of the distributed safety concept:

The logic of the safety functions is implemented by software. Safety-oriented PROFI-safe communication and the use of a safety-oriented control system are required. Integration of the safety technology in the standard automation is realized through a single bus system (see Advantages of PROFI-safe), using PROFIBUS as well as PROFINET.

High degree of flexibility with safety technology Failsafe motor starters for PROFI-safe

In EMERGENCY STOP applications, the Failsafe motor starters are selectively switched off through the upstream PM-D F PROFI-safe safety module. For each safety module, six switch-off groups can be formed. In the first delivery stage, the fail-safe freely-programmable logic of the SIMATIC controller is used to interface with the relevant fail-safe sensor technology.

F-CM contact multipliers

The interface between PROFI-safe and installations that use conventional safety technologies is implemented through the F-CM fail-safe contact multiplier with four floating contacts.

Motor starters and safety motor starters Safety local and PROFIsafe modules

PM-D F PROFIsafe safety modules

The PM-D F PROFIsafe safety module receives the shutdown signal from the interface module of the ET 200S and safely switches off 1 to 6 switch-off groups. This safety module is used in PROFIsafe applications where there is a need for the selective safety shutdown of Failsafe motor starters/frequency converters.



PM-D F PROFIsafe with TM-PF30 S47-F0 terminal module

Terminal modules

The terminal assignment of the terminal modules for safe motor starters corresponds to the terminal assignment of the 45 mm and 65 mm terminal modules. The terminal modules for safe motor starters also have a coding module. This enables the safe motor starter to be assigned to one of the six switch-off groups.

The terminal module contains three coding elements which fully cover the three coding openings in the terminal module. The labeled coding element contains (in the chamber marked with the dash) the busbar tap; the non-labeled coding elements are used only to cover the coding openings. Switch-off group 1 (AG1 or SG1) is coded in the as-delivered state. The coding can be changed to switch-off group 2 by releasing the coding element and turning it through 180°. Changing the coding to switch-off group 3 is possible by exchanging the labeled and blank coding elements. In this case the dash on the labeled coding element must correlate with the dash of the required switch-off group (symbolized busbar).

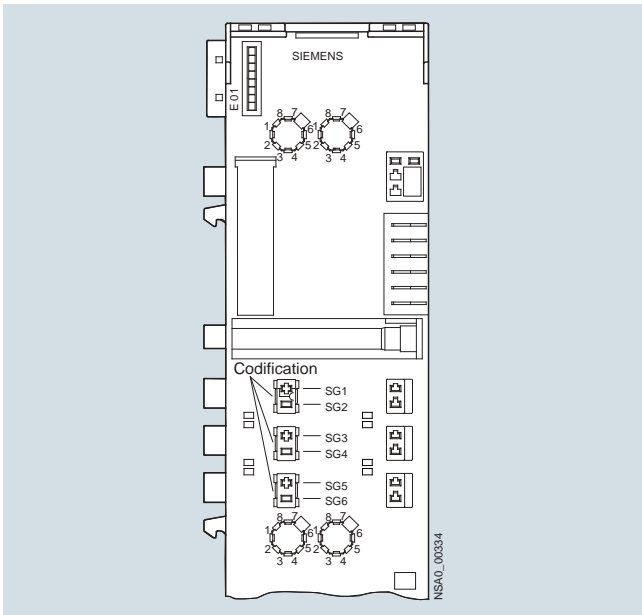

The Failsafe motor starters are assigned to one of the six possible switch-off groups.

Example:

The diverse possible uses of the Safety motor starter Solution PROFIsafe are presented in the manual SIMATIC ET 200S Motor Starters in the context of typical sample applications.

Safety functional examples for easy, quick and low-cost implementations of applications with Safety motor starter Solution PROFIsafe are available on the Internet:

More information can be found on the Internet at:
www.siemens.com/ET200S

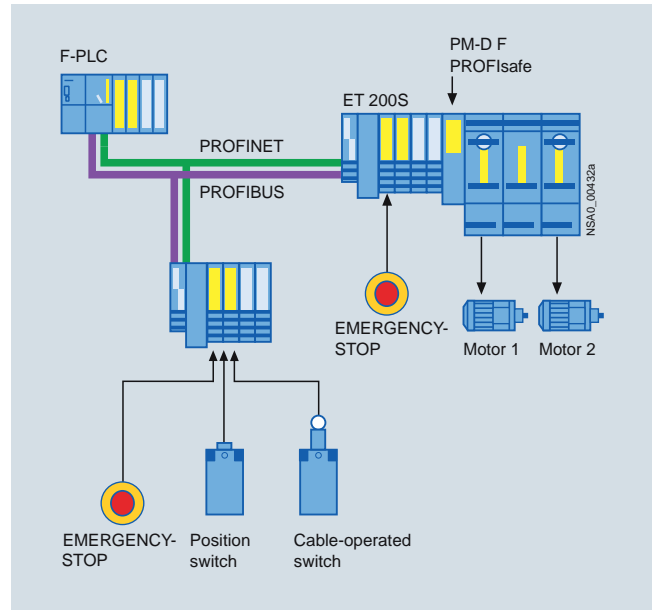

ET 200S Safety motor starter Solution PROFIsafe with Failsafe motor starters and fully selective disconnection (PM-DF PROFIsafe application)

Within an ET 200S station the Failsafe motor starters are assigned to one of 6 safety segments. For plants with distributed configuration the shutdown signals of these safety segments are preferably issued by a higher-level, safety-oriented control system through PROFIsafe. This permits the greatest flexibility for assigning the motor starters to different safety circuits.

Alternatively, an ET 200S F-CPU can also be used for control purposes.

If a safety-oriented SIMATIC CPU is used, the ET 200S is available as safety-oriented I/O. Nevertheless, in such a station it is possible to configure conventional motor starters and input/output modules mixed with modules with safety functions.

Thanks to the PROFIsafe profile, the safety functions are available in the complete network, which means that the Safety motor starter Solution PROFIsafe enables the selective disconnection of Failsafe motor starters or the disconnection of a group of Standard and High Feature motor starters regardless of where and on which I/O station the safe control devices were connected. As such, this solution provides an unprecedented level of flexibility and reduction of wiring for applications in wide-spread plants or with a sporadic demand for changes in the assignment of safety segments.

The Safety motor starter Solution PROFIsafe is ideally suited for safety concepts with Cat. 2 to 4 according to ISO 13849-1 and up to SIL 3 according to IEC 62061.

Each safety module switches up to 6 switch-off groups for Failsafe motor starters/frequency converters.

SIMATIC ET 200 distributed I/O

ET 200S

Motor starters and safety motor starters
Safety local and PROFIsafe modules

Technical specifications

Safety modules PM-D F1, F2, F3, F4 and F5		
Mechanical endurance	Operat. cycles	10 x 10 ⁶
Electrical endurance	Operat. cycles	200 000 at I_e
Utilization category		DC-13
Control times		
• Minimum command duration	ms	200
• Recovery time	s	< 1
• OFF-delay	ms	30
Control circuit U_1		
• Rated control supply voltage U_s	V DC	24
• Operating range DC up to 60 °C		0.85 ... 1.2 x U_s
• Power consumption	W	2.4
• Recommended short-circuit protection		gG 2 A
• Output OUT+/OUT- for controlling expansion modules		24 V DC/< 50 mA (PTC fuse)
Switched auxiliary circuit U_2		
• Rated control supply voltage U_s	V DC	24
• Operating range DC up to 60 °C		0.85 ... 1.2 x U_s
• Rated operational current I_e (13 ... 24 V DC)	A	4
• Uninterrupted thermal current I_{th}	A	5
Recommended short-circuit protection for enabling and signaling circuits		Fuse links: LV HRC type 3NA, DIAZED type 5SB, NEOZED type 5SE Operating class gG 6 A
Supply of		
• Motor starters		Yes
• Electronic modules		No
• Ex(i) modules		No
• BG certification		Yes
• UL, CSA certification		Yes
Cable length for EMERGENCY-STOP and ON buttons	m	max. 1 000
Mounting dimensions (W x H x D)	mm	30 x 196.5 x 117.5 (incl. terminal module)
Enabling circuits with PM-D F5		4 (floating)

PM-D FX1 safety module (infeed terminal module)

Dimensions		
Mounting dimensions (W x H x D)	mm	30 x 196.5 x 117.5 (incl. terminal module)
Module-specific data		
Ambient temperature	°C	0 ... +60
Degree of protection		IP20
Maximum achievable safety classes		SIL 3
• IEC 62061		Tripping class 5 and 6
• DIN V 19250		PL e
• ISO 13849-1		
Safety characteristics		
Proof-test interval		10 years
Voltages, currents, potentials		
Rated control supply voltage U_s	V DC	21.6 ... 26.4 to 60 °C
Rated operational current I_e	A	6
Recommended upstream short-circuit protection	A	Fuse gG 6.3
Supply of		
• Failsafe motor starters		Yes
• Failsafe frequency converters		Yes
• Electronic modules		No
• Ex[i] modules		No
Current consumption		
• From the backplane bus	mA	≤ 10
• from U_1	mA	≤ 35
• from SGx	mA	≤ 15
Status, alarms, diagnostics		
Alarms		None
Diagnostics functions		
• Group fault/device fault		Red LED "SF"
• Monitoring of the electronics power supply U 1 (PWR)		Green LED "PWR"
• Monitoring of six switch-off groups		Green LED SG1 ... SG6
• Diagnostics information can be read out		Yes
Standards, approvals		
• TÜV		Yes
• UL, CSA certification		Yes

F-CM contact multipliers		
Dimensions		
Dimensions (W x H x D)	mm	30 x 196.5 x 117.5 (incl. terminal module)
Module-specific data		
Number of relay outputs		4 (4 x 1-channel or 2 x 2-channel safe coupling/ contact multiplication)
Internal power supply for busbar		U1 (from PM-D F / PM-D FX1)
Maximum achievable safety class		SIL3
• According to IEC 62061		AK 6
• According to DIN VDE 0801		Cat. 4
• According to ISO 13849-1		
Voltages, currents, potentials		
Switching capacity of relay outputs		Utilization category DC-13 (I_e/U_e): 1.5 A/24 V
Galvanic isolation		
• Between outputs and backplane bus		Yes
• Between outputs and power supply		Yes
• Between outputs		Yes
• Between outputs/power supply and shield		Yes
Status, alarms, diagnostics		
Status display		PWR and STAT
Alarms: Diagnostic interrupt		None
Diagnostics functions		Yes
• Group fault display		Red LED (SF)
• Diagnostics information can be read out		possible
• Monitoring of the electronics power supply U_1 (PWR)		Green LED "PWR"
• Monitoring of the switching status of the enabling circuit		Red/green LED STAT
PM-D F PROFIsafe safety modules		
Dimensions		
Dimensions (W x H x D)	mm	30 x 196.5 x 117.5 (incl. terminal module)
Module-specific data		
Number of outputs, switching to P potential		6 switch-off groups (safety group 1 ... 6)
Internal power supply for busbar		U1
Assigned address range		
• in the PII	Byte	5
• in the PIQ	Byte	5
Maximum achievable safety class		SIL3
• According to IEC 62061		AK 6
• According to DIN VDE 0801		Cat. 4
• According to ISO 13849-1		
Voltages, currents, potentials		
Supply voltage	V	24 DC
Galvanic isolation		
• Between outputs and backplane bus		Yes
• Between outputs and power supply		No
• Between outputs		No
• Between outputs/power supply and shield		Yes
Status, alarms, diagnostics		
Status display		Green LED per SG Green LED for electronics supply Green LED for load voltage
Alarms: Diagnostic interrupt		"AN"
Diagnostics functions		
• Group fault display		Red LED (SF)
• Diagnostics information can be read out		possible
Settings		
Module address		Diverse: 1. Using a safety-related parameter in the parameterization message frame via the backplane bus 2. Using the 10-pole DIL switch (binary-coded) on the left side of the module The received address is then compared with the DIL switch position.

SIMATIC ET 200 distributed I/O

ET 200S

Motor starters and safety motor starters
Safety local and PROFIsafe modules

Selection and ordering data

	Version	Order No.
Safety modules local		
 <p>3RK1 903-3DA00</p>	PM-D F1 with diagnostics Safety module for EMERGENCY-STOP application Monitored start	3RK1 903-1BA00
	PM-D F2 with diagnostics Safety module for protective door monitoring Automatic start	3RK1 903-1BB00
	PM-D F3 with diagnostics Safety module for expanding PM-D F1/2 for another voltage group Time-delayed 0 to 15s	3RK1 903-1BD00
	PM-D F4 with diagnostics Safety module for expanding PM-D F1/2 for another voltage group	3RK1 903-1BC00
	PM-D F5 with diagnostics Safety module for expanding PM-D F1...4 with four floating enabling circuits Contact multipliers	3RK1 903-1BE00
	PM-D FX1 with diagnostics Infeed terminal module for supply of 1 to 6 switch-off groups	3RK1 903-3DA00
	FC-M contact multipliers With 4 safe floating contacts	3RK1 903-3CA00
Safety modules PROFIsafe		
	PM-D F PROFIsafe safety modules For PROFIBUS and PROFINET For Failsafe motor starters For Failsafe contact multipliers With six switch-off groups (SG1 to SG6)	3RK1 903-3BA02
	F-CM contact multipliers With 4 safe floating contacts	3RK1 903-3CA00

Overview**Terminal module for PM-D F1/F2/F3/F4/F5 safety modules**

For supplying load and sensor voltage to the self-assembling voltage buses of the Standard motor starters, High Feature motor starters, and frequency converters. Safety modules for voltage monitoring are plugged onto TM-P modules. TM-P modules can be used any number of times within the ET 200S. A safety module must always be plugged upstream from the first motor starter.

Different safety circuits can be functionally separated or else cascaded using different terminal modules. Each group in such a case must be terminated with a PM-X safety module (connection module).

TM-PF30 S47-B1

The terminal module is always positioned at the beginning of a safety segment and accommodates the PM-DF1 safety module for EMERGENCY STOP applications or the PM-DF2 safety module for protective door monitoring. The 24 V control supply voltages for the electronics (U1) and those for supplying the contactors (U2) of the motor starters must be connected to this terminal module along with the 2-channel connection of the safety sensors (e.g. EMERGENCY STOP pushbuttons). Connections for the ON button (enabling) and safe output of the safety module are available in addition.

TM-PF30 S47-B0

The terminal module is used to cascade lower level safety segments and accommodates the PM-DF1 safety module for EMERGENCY-STOP applications or the PM-DF2 safety module for protective door monitoring. No other auxiliary voltage has to be connected to this terminal module. The supply comes from the preceding PM-DF1 or PM-DF2 module over the potential bars of the terminal modules. Once the potential of the preceding safety module is disconnected, this sub-potential also has no voltage.

TM-PF30 S47-C1

The terminal module is always positioned at the beginning of a safety segment expansion in a new station, e.g. at an interlace point. It accommodates the PM-D F3 safety module for time-delayed shutdown or the PM-D F4 safety module for direct shutdown in separately located ET 200S stations. The 24 V control supply voltages for the electronics (U1) and those for supplying the contactors (U2) are fed in new.

The shutdown command from an upstream ET 200S station is received through a safe input. Separate terminals are available to connect the feedback circuit to the upstream ET 200S station. No safety sensors can be connected to this terminal module.

TM-PF30 S47-C0

The terminal module is used to cascade lower-level safety segments and accommodates the PM-D F3 safety module for time-delayed shutdown, or the PM-D F4 safety module. Only the U2 control supply voltage for the contactors must be connected to this terminal module. The U1 supply comes from the preceding safety module (sub-potential group) over the potential bars of the terminal modules. No safety sensors can be connected to this terminal module.

TM-PF30 S47-D0

The terminal module is used to accommodate the PM-D F5 safety module. On this terminal module, safe signals can be relayed to external systems through four groups, each with two safety relay contacts configured with redundancy. The terminal module must always be positioned between one of the above mentioned terminal modules and a terminal module for the TM-X connection module. No safety sensors can be connected to this terminal module.

Terminal module for PM-X safety module (TM-X)TM-X15 S27-01

For connection of an external infeed contactor (second shutdown option) for SIL 2 and SIL 3 or PL d and PL e. The PM-X safety module (connection module) is plugged in on the right next to the last motor starter of a safety segment. On the TM-X terminal module there are the terminals for connecting the positively driven NC contact of the contactors as well as the terminals for connecting the contactor coil. If no contactor with redundant switching is required, e.g. for PL c (ISO 13849-1), the feedback circuit has to be closed at these terminals with a jumper. In applications with external safety relays it is also used instead of the safety module as interface to the external safety relay.

SIMATIC ET 200 distributed I/O

ET 200S

Terminal modules for Safety local and PROFIsafe modules

Technical specifications

TM-PFX30 S47/TM-PF30 S47 terminal modules		
Dimensions		
• Mounting dimensions (W x H x D)	mm	30 x 196.5 x 102
• Depth with power module	mm	117.5
Insulating voltages and rated currents		
• Insulating voltage	V	500
• Rated operational voltage	V DC	24
• Rated operational current	A	10
Conductor cross-sections		
• Solid	mm ²	1 x (0.14 ... 2.5), according to IEC 60947 1 x 2.5
• Finely stranded with end sleeve	mm ²	1 x (0.14 ... 1.5), according to IEC 60947
• AWG cables, solid or stranded	AWG	1 x (18 ... 22)
Wiring		
• Required tool		Standard screwdriver size 1
• Tightening torque	Nm	0.4 ... 0.7

Selection and ordering data

Version	Order No.
---------	-----------

Terminal modules for Safety local modules



3RK1 903-1AA00

TM-PF30 S47-B1 terminal module For PM-D F1/2 safety modules With infeed U1/U2 and sensor connection	3RK1 903-1AA00
TM-PF30 S47-B0 terminal module For PM-D F1/2 safety modules With sensor connection	3RK1 903-1AA10
TM-PF30 S47-C1 terminal module For PM-D F3/4 safety modules With infeed U1/U2 and control input IN+/IN-	3RK1 903-1AC00
TM-PF30 S47-C0 terminal module For PM-D F3/4 safety modules With infeed U2	3RK1 903-1AC10
TM-PF30 S47-D0 terminal module For PM-D F5 safety modules	3RK1 903-1AD10
TM-X15 S27-01 terminal module For PM-X safety modules	3RK1 903-1AB00
TM-P15-S27-01 terminal modules for PM-D power module	3RK1 903-0AA00
TM-PFX30 S47-G0/G1 terminal module For PM-D FX1 safety modules (infeed terminal modules)	
• Infeed left (TM-PFX30 S47-G0)	3RK1 903-3AE10
• Infeed center (TM-PFX30 S47-G1)	3RK1 903-3AE00
TM-FCM30 S47-F01 terminal module For F-CM contact multipliers	3RK1 903-3AB10

Terminal modules for Safety PROFIsafe modules

TM-PF30 S47-F0 terminal module For PM-D F PROFIsafe safety modules	3RK1 903-3AA00
TM-FCM30 S47-F01 terminal module For F-CM contact multipliers	3RK1 903-3AB10

Overview

Accessories for Standard motor starters

Control kit

The control kit for the Standard motor starter provides the possibility of testing the motor during start-up or service by actuating the motor starter protector. Using the control kit with the motor starter protector tripped, the contactor is mechanically locked in the ON position.

Control unit

With the control unit the contactor coils of the Standard motor starter can be directly controlled using 24 V DC. The motor starter can thus be started as normal using a local control station without PLC or bus.

Note:

The control unit cannot be used in combination with the safety system or a brake control module.

DM-V15 distance module

- Passive module without bus connection and terminals
- Does not need a separate terminal module
- Follows a TM-DS45 or TM-RS90 or TM-xB if required
- Does not need to be taken into account when configuring the GSD file

The distance module is available for applications with high motor currents or high ambient temperatures involving Standard motor starters. It can be used to the right and left of a DS1-x direct-on-line starter, or to the right of an xB1...4 brake module in order to improve heat dissipation to the side. The distance module is a completely passive module and does not need to be taken into account with regard to the control system during configuration. Details of the distance module can be found in the manual "SIMATIC ET 200S". If you have any queries concerning the use of the distance module, contact Technical Support for Siemens Low Voltage Controls (Fax: +49(0)911/895-5907).

Accessories for High Feature motor starters

Control module 2DI LC COM

The 2DI control module is plugged onto the interface on the front of the motor starter. The module provides two inputs which can receive signals from the process and be assigned directly to the starter.

The functionality can be selected from a list of various control functions as part of the PROFIBUS parameterization. Local control station, emergency start and quick stop, for example, are available as functions. The signal levels can also be parameterized (NO/NC). For more extensive control functions the two inputs of a xB3 or x4 brake control module, which is plugged in alongside on the right, can be integrated in addition. The signal states of all inputs are transmitted in parallel with the internal use to the higher-level control system.

When a motor starter is replaced, the parameterization is automatically transmitted by download to the new starter. The inputs on the motor starter ensure autonomous operation, e.g. in the event of PLC failure, on the one hand and short response times through direct processing in the starter on the other hand. Another advantage results from the direct assignment of functions to modular machine concepts.

The 2DI LC COM control module has in addition a PC interface for connecting the ES Motor Starter parameterization and diagnostics software switch (Version 2.0 and higher). The module works solely on High Feature motor starters with Motor Starter ES interface. The Logo! PC cable is used as connecting cable be-

tween the 2DI LC COM control module and the High Feature motor starter.

Accessories for Standard and High Feature motor starters

PE/N bridge module

PE/N bridge modules are used to bridge gaps in the PE/N bus which are caused, for example, by using brake control modules, PM-D(F) power modules or PM-X connection modules. If a bridge module is used, the supply must not be fed in anew. They are available in 15 mm and in 30 mm widths.

Bridge modules L123

The L123 bridge modules are used to bridge gaps in the power bus (see above). They are available in 15 mm and in 30 mm widths.

Brake control module

For motors with mechanical brake (see "General data" → "Overview", page 9/148)

Terminal modules for brake control modules

The TM-xB terminal modules are used to accommodate the xB1, xB2, xB3 and xB4 brake control modules. The TM-xB terminal module must always follow immediately after a terminal module for Standard motor starters, High Feature motor starters, or frequency converters as control of the electronic braking switch is provided through an output of the motor starter/frequency converter. The xB215 terminal modules for the brake control modules have not only the terminals for connecting the cable for the motor brake but also the terminals of the two local acting inputs. These local inputs are not evaluated by a frequency converter, which is why the xB215 terminal module can only be switched behind a motor starter.

Accessories for Standard, High Feature and Failsafe motor starters

PE/N terminal blocks

The PE/N terminal block is required for direct connection of the protective conductor in the motor cable without intermediate terminals. It is plugged together with the terminal module for motor starters or frequency converters before the latter is mounted on the standard mounting rail. With two PE terminals and one N terminal the "-F" version is connected to the "-S32" terminal modules for motor starters or frequency converters. The "-S" version is combined with the "-S31" terminal module. The "F" terminal modules are delivered with two caps for closing the PE/N bus contacts on the final terminal module of a segment. The modules for the Standard motor starters have a width of 45 mm and the modules for the High Feature motor starters and frequency converters have a width of 65 mm.

There is no electrical connection between the terminals of the PE/N terminal block and the integrated shielding of the frequency converter. The PE/N terminal block must therefore not be used for the shielding of the motor cable.

Accessories for Safety local modules

The Failsafe Kit (F-Kit) is required for Standard motor starters in a safety segment (see page 9/166).

SIMATIC ET 200 distributed I/O

ET 200S



Motor starters and safety motor starters Accessories

Technical specifications

Brake control modules xB1, xB2, xB3, xB4, xB5, xB6

		xB1	xB3	xB2	xB4	xB5	xB6
Dimensions (W x H x D)	mm	15 x 196.5 x 125.5 including terminal module on 7.5 mm standard mounting rail					
Rated operational voltage	V	24 DC		500 DC (at least 100)		400 AC	
Power supply		Externally through terminal module		From brake rectifier through terminal module		Externally through terminal module	
Rated operational current	A	4		0.7		0.5	
Reverse polarity protection		No, in the event of polarity reversal the brake is released and the overload/short-circuit protection is ineffective				Not relevant	
Overload/short-circuit protection		Solid-state				1 A fuse	
Conductor cross-section of terminal module for brake control module	mm ²	1 x 2.5 without end sleeve 1 x 1.5 with end sleeve					
Number of outputs		0	1 (used internally)	0	1 (used internally)	0	1 (used internally)
Number of inputs		0	2	0	2	0	2
Address space required per module							
• With summary		0	2 bits	0	2 bits	0	2 bits
• Without summary		0	1 byte	0	1 byte	0	1 byte
Diagnostics functions							
• SF group error		Red LED					
• STAT brake switching status		Yellow LED					
• Inputs 1 and 5		--	Green LED	--	Green LED	--	Green LED
Parameters (default value underlined>							
• Brake overload diagnostics		--	<u>disable</u> / enable	--	<u>disable</u> / enable	--	
• Input delay	ms	--	0 / 0.1 / 0.5 / <u>3</u> / 15	--	0 / 0.1 / 0.5 / <u>3</u> / 15	--	0 / 0.1 / 0.5 / <u>3</u> / 15

Selection and ordering data

Version	Order No.
Accessories for Standard motor starters	
 3RK1 903-0CA00	Control kits for manually operating the contactor contacts during start-up and servicing (one set contains five control kits) 3RK1 903-0CA00
 3RK1 903-0CG00	Control units for direct contactor control (manual control) 24 V DC 3RK1 903-0CG00
 3RK1 903-0CD00	DM-V15 distance modules for DS1-x direct-on-line starters with high temperatures or high current load 15 mm wide 3RK1 903-0CD00





Version	Order No.	
Accessories for Standard motor starters (continued)		
 <p>3RK1 903-2AA00</p>	<p>PE/N M45-PEN-F terminal blocks 45 mm wide including two caps in combination with TM-DS45-S32 / TM-RS90-S32</p>	<p>3RK1 903-2AA00</p>
 <p>3RK1 903-2AA10</p>	<p>PE/N M45-PEN-S terminal block 45 mm wide in combination with TM-DS45-S31 /TM-RS90-S31</p>	<p>3RK1 903-2AA10</p>
Accessories for High Feature motor starters		
 <p>3RK1 903-0CH20</p>	<p>2DI LC COM control module Digital input module with two inputs (cable length up to 100 m) for local motor starter functions for mounting onto the front of motor starters, operational voltage 24 V DC (supplied from U_1), short-circuit proof, floating contact with serial interface for connecting Motor Starter ES, connection using LOGO! PC cable</p>	<p>3RK1 903-0CH20</p>
 <p>3RK1 922-3BA00</p>	<p>Hand-held device for ET 200S High Feature motor starters (or for ET 200pro and M200D motor starters) for local operation. The motor-starter-specific serial interface cables must be ordered separately. The LOGO! PC cable is used for the MS ET 200S HF.</p>	<p>3RK1 922-3BA00</p>
 <p>6ED1 057-1AA00-0BA0</p>	<p>LOGO! PC cable For connecting the ET 200S High Feature motor starters to the RS232 interface of a PG/PC/laptop (with the Motor Starter ES software) or the hand-held device 3RK1 922-3BA00.</p>	<p>6ED1 057-1AA00-0BA0</p>
<p>M65-PEN-F terminal blocks 65 mm wide, including two caps, in combination with TM-DS65-S32 / TM-RS130-S32</p>		<p>3RK1 903-2AC00</p>
<p>M65-PEN-S terminal blocks 65 mm wide, in combination with TM-DS65-S31 / TM-RS130-S31</p>		<p>3RK1 903-2AC10</p>

SIMATIC ET 200 distributed I/O

ET 200S

Motor starters and safety motor starters
Accessories

Version	Order No.	
Accessories for Standard/High Feature motor starters		
 <p>3RK1 903-0AH00</p>	<p>M15-PE/N bridge module 15 mm wide for bridging a 15 mm module</p>	<p>3RK1 903-0AH00</p>
 <p>3RK1 903-0AJ00</p>	<p>M30-PE/N bridge module 30 mm wide for bridging a 30 mm module</p>	<p>3RK1 903-0AJ00</p>
 <p>3RK1 903-0AE00</p>	<p>M15-L123 bridge module 15 mm wide for bridging a 15 mm module</p>	<p>3RK1 903-0AE00</p>
 <p>3RK1 903-0AF00</p>	<p>M30-L123 bridge module 30 mm wide for bridging a 30 mm module</p>	<p>3RK1 903-0AF00</p>
 <p>3RK1 903-0AF20</p>	<p>Sealing caps for L123 bridge modules and PE/N (bag containing 20 units)</p>	<p>3RK1 903-0AF20</p>
 <p>3RK1 903-0CB00</p>	<p>Brake control modules for motors with mechanical brakes</p> <ul style="list-style-type: none"> • xB1 for motor starters 24 V DC/4 A • xB2 for motor starters 500 V DC/0.7 A • xB3 for motor starters 24 V DC / 4 A / 2 DI 24 V DC local control with diagnostics, with two inputs • xB4 for motor starters 500 V DC / 0.7 A / 2 DI 24 V DC local control with diagnostics, with two inputs • xB5 for motor starters 400 V AC without digital input • xB6 for motor starters 400 V AC with two digital inputs 	<p>3RK1 903-0CB00</p> <p>3RK1 903-0CC00</p> <p>3RK1 903-0CE00</p> <p>3RK1 903-0CF00</p> <p>3RK1 903-0CJ00</p> <p>3RK1 903-0CK00</p>
	<p>Terminal modules for brake control modules</p> <ul style="list-style-type: none"> • TM-xB15 S24-01 for xB1, xB2, or xB5 • TM-xB215 S24-01 for xB3, xB4, or xB6 	<p>3RK1 903-0AG00</p> <p>3RK1 903-0AG01</p>

Version	Order No.
Accessories for Failsafe motor starters	
M65-PEN-F terminal block With incoming connection, with caps	3RK1 903-2AC00
M65-PEN-S terminal block without incoming connection	3RK1 903-2AC10
Accessories for safety local modules	
 PM-X safety module (connection module) with diagnostics, can be plugged into TM-X15 S27-01 Module for connecting a safety group and for connecting an external infeed contactor or for connecting to an external safety circuit	3RK1 903-1CB00
 F-Kit 1 Failsafe equipment for DS1-x ¹⁾ Standard motor starters	3RK1 903-1CA00
 F-Kit 2 Failsafe equipment for RS1-x ¹⁾ Standard motor starters	3RK1 903-1CA01
 3RK1 903-1CA00	
 3RK1 903-1CA01	
Documentation	
Manual²⁾ SIMATIC ET 200S Motor Starters, Failsafe Motor Starters, Safety-Integrated Systems <ul style="list-style-type: none"> • German • English • French • Italian • Spanish 	3ZX10 12-0RK13-0AB0 3ZX10 12-0RK13-0AC0 3ZX10 12-0RK13-0AD0 3ZX10 12-0RK13-0AF0 3ZX10 12-0RK13-0AE0

¹⁾ The function of the Failsafe Kit is already integrated into High Feature motor starters.

²⁾ <http://support.automation.siemens.com/WWW/view/en/6008567>

SIMATIC ET 200 distributed I/O

ET 200S

Software Motor Starter ES

Overview

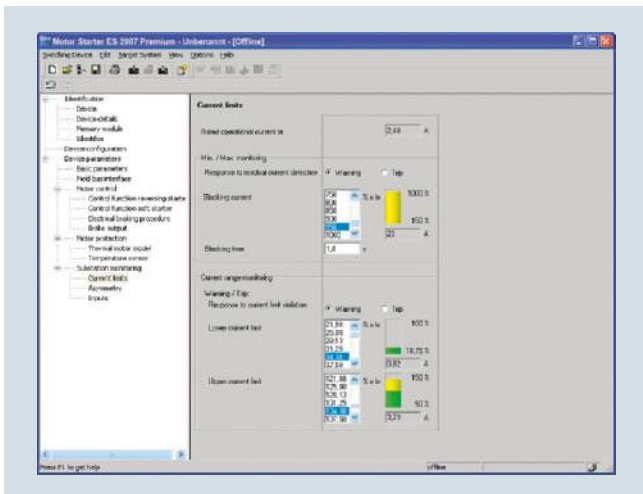

Motor Starter ES for parameterization, monitoring, diagnostics and testing of motor starters

Motor Starter ES is used for commissioning, parameterization, diagnostics, documentation, and the preventative maintenance of the motor starters in the SIMATIC ET 200S, ET 200pro, ECOFAST, and M200D product families.

Interfacing is performed

- over the local interface on the device
- with PROFIBUS DP V1-capable motor starters from any point in PROFIBUS or in PROFINET (applies for ET 200S DP V1/ ET 200pro/ECOFAST/M200D)
- with PROFINET-capable motor starters from any point in PROFINET or in PROFIBUS (applies to ET 200S DP V1, ET 200pro/M200D)

Using Motor Starter ES, the communication-capable motor starters are easily parameterized during commissioning, monitored during normal operation, and successfully diagnosed for service purposes. Preventive maintenance is supported by a function for reading out diverse statistical data (e.g. operating hours, operating cycles, cut-off currents, etc.). The user is supported during these procedures with comprehensive Help functions and plain text displays.

Motor Starter ES can either be used as a stand-alone program or it can be integrated into STEP 7 via an object manager.

Efficient engineering with three program versions

The Motor Starter ES software program is available in three versions which differ in their user-friendliness, scope of functions, and price.

Motor Starter ES	Basic	Standard	Premium
ET 200S High Feature PROFIBUS IM	✓	✓	✓
ET 200S High Feature PROFINET IM	✓	✓	✓
ECOFAST AS-Interface High Feature	✓	✓	--
ECOFAST PROFIBUS	✓	✓	✓
ET 200pro PROFIBUS IM	✓	✓	✓
ET 200pro PROFINET IM	✓	✓	✓
M200D AS-Interface Standard	✓	✓	(✓)
M200D PROFIBUS	✓	✓	✓
M200D PROFINET	✓	✓	✓

✓ Function available, (✓) available with restricted functionality

-- Function not available

Motor Starter ES	Basic	Standard	Premium
Access through the local interface on the device	✓	✓	✓
Parameterization	✓	✓	✓
Operating	✓	✓	✓
Diagnostics	--	✓	✓
Creating typicals	--	✓	✓
Comparison functions	--	✓	✓
Standard-compliant printout according to EN ISO 7200	--	✓	✓
Service data (min/max pointer, statistics data)	--	✓	✓
Access via PROFIBUS	--	--	✓
Access via PROFINET	--	--	✓
S7 routing	--	--	✓
Teleservice via MPI	--	--	✓
STEP 7 object manager	--	--	✓
Trace function	--	✓	✓

✓ Function available

-- Function not available

More functions

- Standard-compliant printouts
The software tool greatly simplifies machine documentation. It enables parameterization printouts according to EN ISO 7200. The elements to be printed are easy to select and can be grouped as required.
- Easy creation of typicals
Typicals can be created for devices and applications with only minimum differences in their parameters. These typicals contain all the parameters which are needed for parameterization. In addition it is possible to specify which of these parameters are fixed and which can be adapted, e.g. by the startup engineer.
- Teleservice via MPI
The Motor Starter ES Premium version supports the use of MPI Teleservice (comprising the Teleservice software and various Teleservice adapters) for remote diagnostics of the devices. This facilitates diagnostics and maintenance, and it shortens response times for service purposes.

Types of delivery and license

Motor Starter ES is available as follows:

- Floating license – the license for any one user at any one time
 - Authorizes any one user
 - regardless of the number of installations (unlike the single license which may be installed only once)
 - Only the actual use of the program has to be licensed
 - Trial license (free use of all program functions for 14 days for test and evaluation purposes, included on every product CD, available in the download file of the SIRIUS ES program in the Service&Support portal).

Following delivery versions are available in addition for Motor Starter ES 2007:

- Upgrade
Switching from an old to a new version with expanded functions, e.g. upgrade from Motor Starter ES 2006 to Motor Starter ES 2007.
- PowerPack
Special pack for switching within the same software version to a more powerful version with more functionality, e.g. Power-Pack Motor Starter ES 2007 for switching from Standard to Premium.
- Software Update Service
To keep you up to date at all times we offer a special service which supplies you automatically with all service packs and upgrades.
- License download
User-friendly license key download from our Mall (for selected countries) as an easy and quick way for you to receive additional licenses for your software.
For further information see www.siemens.com/tia-online-software-delivery.

System requirements

Parameterization, start-up and diagnostics software Motor Starter ES 2007 For ECOFAST motor starters, SIMATIC ET 200S High Feature starters, SIMATIC ET 200pro starters, and M200D (AS-I standard, PROFIBUS, PROFINET)	
Operating system	Windows XP Professional (Service Pack 2 or 3) Windows 7 32/64-bit Professional/Ultimate/Enterprise (Service Pack 1)
Processor performance	≥ Pentium 800 MHz/≥ 1 GHz (Windows 7)
Work memory	≥ 512 MB (Windows XP Professional)/≥ 1 GB (Windows 7 32-bit)/ ≥ 2 GB (Windows 7 64-bit)
Monitor resolution	≥ 1024 x 768
Free space on hard disk¹⁾	≥ 400 MB
CD-ROM/DVD drive	✓ (only when installing from CD)
Interface	depends on PC cable: serial (COM) or USB
PC cable/parameterization cable/connection cable	✓
PROFIBUS card/PROFIBUS processor	Optional, for parameterization and diagnostics through PROFIBUS
Ethernet interface/PROFINET card	Optional, for parameterization and diagnostics through PROFINET

✓ Required

¹⁾ Additional free space recommended, e.g. for swap-out file.

Benefits

- Rapid and fault-free configuration and commissioning of motor starters without profound previous knowledge
- Transparent setting of the device functions and their parameters – on- and offline
- Effective diagnostic functions on the soft starter; the most important measured values are displayed
- Trace function (oscilloscope function) for recording measured values and events (included in the Motor Starter ES Standard and Premium software versions for M200D PROFIBUS and PROFINET).

SIMATIC ET 200 distributed I/O

ET 200S

Software Motor Starter ES

Selection and ordering data

Parameterization, start-up and diagnostics software Motor Starter ES 2007

For ECOFAST motor starters, SIMATIC ET 200S High Feature starters, SIMATIC ET 200pro starters, and M200D (AS-I standard, PROFIBUS, PROFINET)

Version	Order No.
Motor Starter ES 2007 Basic	
 <p>Floating License for one user Engineering software, software and documentation on CD, 3 languages (German/English/French), communication through system interface</p> <ul style="list-style-type: none"> • License key on USB stick, Class A, including CD • License key download, Class A, no CD 	<p>3ZS1 310-4CC10-0YA5 3ZS1 310-4CE10-0YB5</p>
Motor Starter ES 2007 Standard	
<p>Floating License for one user Engineering software, software and documentation on CD, 3 languages (German/English/French), communication through system interface</p> <ul style="list-style-type: none"> • License key on USB stick, Class A, including CD • License key download, Class A, no CD 	<p>3ZS1 310-5CC10-0YA5 3ZS1 310-5CE10-0YB5</p>
<p>Upgrade for Motor Starter ES 2006 Floating License for one user, engineering software, software and documentation on CD, license key on USB stick, Class A, 3 languages (German/English/French), communication through the system interface</p>	<p>3ZS1 310-5CC10-0YE5</p>
<p>PowerPack for Motor Starter ES 2007 Basic Floating License for one user, engineering software, license key on USB stick, Class A, 3 languages (German/English/French), communication through the system interface</p>	<p>3ZS1 310-5CC10-0YD5</p>
<p>Software Update Service For 1 year with automatic extension, requires current software version, engineering software, software and documentation on CD, communication through the system interface</p>	<p>3ZS1 310-5CC10-0YL5</p>

Notes:

Please order PC cable separately, [see page 9/183](#).

For description of the software versions [see page 9/180](#).

Version	Order No.
Motor Starter ES 2007 Premium	
Floating License for one user Engineering software, software and documentation on CD, 3 languages (German/English/French), communication through system interface or PROFIBUS <ul style="list-style-type: none"> • License key on USB stick, Class A, including CD • License key download, Class A, no CD 	3ZS1 310-6CC10-0YA5 3ZS1 310-6CE10-0YB5
Upgrade for Motor Starter ES 2006 Floating License for one user, engineering software, software and documentation on CD, license key on USB stick, Class A, 3 languages (German/English/French), communication through the system interface or PROFIBUS	3ZS1 310-6CC10-0YE5
PowerPack for Motor Starter ES 2007 Standard Floating License for one user, engineering software, license key on USB stick, Class A, 3 languages (German/English/French), communication through the system interface or PROFIBUS	3ZS1 310-6CC10-0YD5
Software Update Service For 1 year with automatic extension, requires current software version, engineering software, software and documentation on CD, communication through the system interface or PROFIBUS	3ZS1 310-6CC10-0YL5

Notes:Please order PC cable separately, see [Accessories](#).For description of the software versions see [page 9/180](#).**Accessories**

Version	Order No.
Optional accessories	
 For ET 200S motor starter High Feature Control module 2DI LC COM For ET 200S High Feature starters, Failsafe starters A	3RK1 903-0CH20
LOGO! PC cable	6ED1 057-1AA00-0BA0
For ET 200pro and MD200D motor starters RS 232 interface cable Serial data connection between ET 200pro MS/FC, M200D and laptop/PC/PG or MS	3RK1 922-2BP00
USB interface cable Serial data connection between ET 200pro MS/FC, M200D and laptop/PC/PG or MS	6SL3 555-0PA00-2AA0
For ECOFAST High Feature motor starters (interface cable) PC cable	3RK1 911-0BN20
USB/serial adapters for connecting an RS 232 PC cable to the USB interface of a PC, recommended for use in conjunction with ET 200S/ECOFAST/ET 200pro motor starters	3UF7 946-0AA00-0

3RK1 903-0CH20

SIMATIC ET 200 distributed I/O

ET 200S

Add-on products for the ET 200S EtherNet/IP interface module

Overview

An interface module (Ethernet/IP adapter) is provided for operating the ET 200S on Ethernet/IP. It can be used together with system and IO components of the ET 200S distributed I/O system.

Technical specifications

Order number	ZNX:EIP-200S (Basis Version)
Product type designation	EtherNet/IP header module for ET 200S
General information	
• Manufacturer's code (VendorID)	0008h
• Device ID (DeviceID)	0239h
Power and voltage failure backup, min.	20 ms
Input current from supply voltage 1L+, max.	250 mA
Power dissipation, typ.	2.5 W
Address space	
• Outputs	256 bytes
• Inputs	256 bytes
PROFINET IO interface	
• Automatic negotiation of the transmission rate	Yes
• Transfer Rate, max.	100 Mbit/s
• Services	See manual
• RJ45	Yes
Diagnostic indicator LED	
Monitoring 24 V power supply ON (green)	Yes
Connection to the network LINK (green)	Yes
Electrical isolation	
• Between the rear panel bus and electronic components	No
• Between the supply voltage and electronic components	No
• Between Ethernet and electronic components	Yes
Maximum potential difference between different circuits	75 V DC/60 V AC
Isolation test voltage	500 V
Standards, approvals, certificates	CE mark, UL approval
Dimensions	
• Width	60 mm
• Height	119.5 mm
• Depth	75 mm
Weight	120 g

Ordering data

Order No.

SIMATIC ET 200S interface module for EtherNet/IP

Including:

- SD card 2 MB (6ES7 954-8LB01-0AA0)
- Bus termination module for ET 200S (6ES7 193-4JA00-0AA0)
- Connector for 24 V DC supply voltage
- Companion disk with the manuals and the configuration tool

ZNX:EIP-200S

SIMATIC ET 200 distributed I/O

ET 200S

Add-on products for the ET 200S
DeviceNet interface modul

Overview

An interface module (DeviceNet adapter) is provided for operating the ET 200S on DeviceNet. It can be used together with system and IO components of the ET 200S distributed I/O system.

Technical specifications

Order number	ZNX:10000005188 (Basis Version)
Product type designation	DeviceNet Interface Module for ET 200S
Power dissipation, typ.	3.8 W
Address space	
• Outputs	128 bytes
• Inputs	128 bytes
RS 485 interfaces	Yes
Reports	
• PROFINET IO	No
• PROFIBUS DP protocol	No
• Ethernet TCP/IP	No
Isochronous mode (application synchronized up to terminal)	No
Alarms	No
Diagnostics functions	Yes
Connection to the network LINK (green)	Yes
Electrical isolation	
• Between the rear panel bus and electronic components	Yes
• Between electronics block and PROFIBUS DP	Yes
• Between the supply voltage and electronic components	No
Isolation test voltage	500 V
Emission of radio interference acc. to EN 55 011	
• Limit class A, for use in industrial areas	Yes
• Limit class B, for use in residential areas	No
Dimensions	
• Width	45 mm
• Height	109.5 mm
• Depth	75 mm
Weight	300 g

Ordering data

SIMATIC ET 200S interface module for DeviceNet

Including:

- Bus termination module for ET 200S (6ES7 193-4JA00-0AA0)
- Power module PM-E 24 ... 4 V DC/24 ... 230 V AC (6ES7 138-4CB11-0AB0)
- Terminal module TM-P (6ES7 193-4CD30-0AA0)
- Connector for the connection to DeviceNet.

Order No.

ZNX:10000005188

SIMATIC ET 200 distributed I/O

ET 200MP

Introduction

Overview

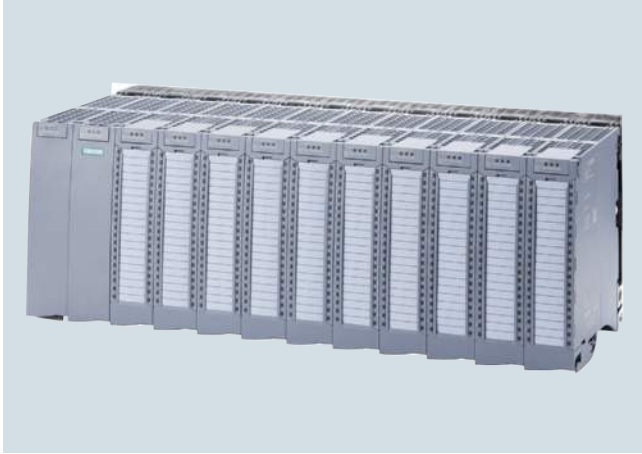

The SIMATIC ET 200MP is a modular and scalable I/O system with IP20 degree of protection for universal use, and offers the same system advantages as the S7-1500. The SIMATIC ET 200MP permits extremely short bus cycles and very fast response times, even with large quantity structures.

SIMATIC ET 200MP consists of the following components:

- Interface module which communicates with all controllers that operate in conformance with the PROFINET standard IEC 61158.
- Up to 30 I/O modules in any combination can be used within an ET 200MP station.

The distributed I/O system is particularly easy to install, wire, and commission. SIMATIC ET 200MP communicates over PROFINET. Its high speed and data transfer rate result in a high system performance.

Highlights:

- Modular I/O system with IP20 degree of protection for PROFINET
- Compact dimensions
- High degree of user-friendliness due to the following design features:
 - Uniform 40-pin front connector simplifies ordering, logistics, and warehousing
 - Uniform pin assignment per module type simplifies wiring and helps avoid errors
 - Integrated potential bridges simplify wiring and allow flexible subsequent modification
 - The cable storage space grows along with the requirements and allows a uniform appearance even with insulated conductors with a large cross-section and/or thick insulation
 - The prewiring position for the front connector allows convenient wiring both when commissioning and making changes during operation
 - The DIN rail integrated in the S7-1500 mounting rail allows snapping-on of many standard components such as additional terminals, miniature circuit breakers or small relays
 - The 1:1 allocation of channel status and diagnostics LED, terminal and inscription allows fast location and elimination of errors. Assistance is provided by the wiring diagram printed on the inside of the front panels.
 - The integrated shielding concept for analog and technology modules allows reliable and rugged operation, in particular with high-speed applications. Installation does not require any tools.
- Comprehensive product portfolio comprising digital and analog input or output modules, technology modules, and communication modules for point-to-point communication; further modules, e.g. F modules, will be available soon
- Extensive system functions
 - Integrated system diagnostics when operated with an S7-1500 and the TIA portal
 - Increase in communication availability due to Media Redundancy Protocol (MRP)
 - Consistent use of identification and maintenance data IM0 to IM3 for fast electronic and unambiguous identification of individual modules (order number, serial number, etc.)
 - Uniform firmware update for the interface module and all I/O modules for subsequent expansion of functions (investment security)
 - Bus cycle time $\geq 250 \mu\text{s}$ and coupling to the isochronous task permit implementation of applications with high performance requirements.
 - Up to 30 I/O modules within a station save on interface modules and installation time
 - Omission of MMC card; automatic address assignment via LLDP or manually via TIA portal or PST tool

Overview



- Interface module for linking the ET 200MP to PROFINET
- Handles data exchange with the PROFINET I/O controller in the PLC
- Integrated 2-port switch for line topology
- Max. 30 I/O modules
- Shortest bus cycle 250 µs
- Linking to the isochronous task of the CPU
- Prioritized fast startup (FSU) with 500 ms (max. 12 I/O modules)
- Media Redundancy Protocol (MRP)
- Shared Device on up to two I/O controllers (when configuring using GSD file; depends on the respective configuration tool)
- Omission of SIMATIC memory card (SMC); IM replacement without PG using LLDP

Technical specifications

6ES7 155-5AA00-0AB0 IM 155-5 PN ST	
General information	
Product function	
• I&M data	Yes; IM0 to IM3
Engineering with	
• STEP 7 TIA Portal can be configured/integrated as of version	V12.0 / V12.0
• STEP 7 can be configured/integrated as of version	as of V5.5 SP3 / -
• PROFINET as of GSD version/GSD revision	V1.0 / V2.23
Supply voltage	
Type of supply voltage	DC
Rated voltage/DC	24 V
Reverse polarity protection	Yes
Short-circuit protection	Yes
Mains buffering	
• Mains/voltage failure stored energy time	5 ms
Hardware configuration	
Modules per rack, max.	30; I/O modules
Interfaces	
Number of PROFINET interfaces	1
1st interface	
• Interface types	
- Number of ports	2
- Integrated switch	Yes
- RJ 45 (Ethernet)	Yes
• Protocols	
- PROFINET IO Device	Yes
- Media redundancy	Yes
Interface types	
RJ 45 (Ethernet)	
• 100 Mbps	Yes
• Transmission procedure	PROFINET with 100 Mbit/s full duplex (100BASE-TX)
• Autonegotiation	Yes
• Autocrossing	Yes

6ES7 155-5AA00-0AB0 IM 155-5 PN ST	
Protocols	
Supports protocol for PROFINET IO	Yes
PROFINET IO Device	
• Services	
- Isochronous mode	Yes
- IRT, supported	Yes
- Prioritized startup	Yes; 500 ms
- Shared device	Yes
- Number of IO controllers with shared device, max.	2
Open IE communication	
• TCP/IP	Yes
• SNMP	Yes
• LLDP	Yes
Isochronous mode	
Isochronous operation (application synchronized up to terminal)	Yes
equidistance	Yes
shortest clock pulse	250 µs
max. cycle	4 ms
Interrupts/diagnostics/status information	
Status indicator	Yes
Alarms	
• Alarms	Yes
Diagnostic messages	
• Diagnostic functions	Yes
Diagnostics indication LED	
• RUN LED	Yes; Green LED
• ERROR LED	Yes; Red LED
• MAINT LED	Yes; yellow LED
• Connection display LINK TX/RX	Yes; yellow LED
Isolation	
Isolation checked with	707 V DC (type test)
Dimensions	
Width	35 mm
Height	147 mm
Depth	129 mm
Weight	
Weight, approx.	310 g

SIMATIC ET 200 distributed I/O

ET 200MP

Interface modules IM 155-5 PN

Ordering data	Order No.	Order No.
IM 155-5 PN interface module IP 20 degree of protection, module width 35 mm, installation on S7-1500 mounting rail	6ES7155-5AA00-0AB0	
Accessories Front flap for IM 155-5 PN (spare part), 5 units	6ES7528-0AA70-7AA	
SIMATIC S7-1500 mounting rail Fixed lengths, with grounding elements <ul style="list-style-type: none"> • 160 mm • 482 mm • 530 mm • 830 mm For cutting to length by customer, without drill holes; grounding elements must be ordered separately <ul style="list-style-type: none"> • 2000 mm 	6ES7 590-1AB60-0AA0 6ES7 590-1AE80-0AA0 6ES7 590-1AF30-0AA0 6ES7 590-1AJ30-0AA0 6ES7 590-1BC00-0AA0	
PE connection element for mounting rail 2 000 mm 20 units	6ES7 590-5AA00-0AA0	
Power supply For supplying the backplane bus of the S7-1500 24 V DC input voltage, power 25 W 24/48/60 V DC input voltage, power 60 W 120/230 V AC input voltage, power 60 W	6ES7 505-0KA00-0AB0 6ES7 505-0RA00-0AB0 6ES7 507-0RA00-0AB0	
Power connector With coding element for power supply module; spare part, 10 units	6ES7 590-8AA00-0AA0	
Load power supply 24 V DC/3 A 24 V DC/8 A	6EP1 332-4BA00 6EP1 333-4BA00	
Power supply connector Spare part; for connecting the 24 V DC supply voltage <ul style="list-style-type: none"> • with push-in terminals 	6ES7 193-4JB00-0AA0	
		IE FC RJ45 plugs RJ45 plug connector for Industrial Ethernet with a rugged metal enclosure and integrated insulation displacement contacts for connecting Industrial Ethernet FC installation cables IE FC RJ45 plug 180 180° cable outlet 1 unit 10 units 50 units IE FC TP Standard Cable GP 2x2 4-core, shielded TP installation cable for connection to IE FC Outlet RJ45/ IE FC RJ45 Plug; PROFINET-compatible; with UL approval; Sold by the meter, max. length 1 000 m; minimum order 20 m IE FC TP Trailing Cable 2 x 2 (Type C) 4-core, shielded TP installation cable for connection to IE FC Outlet RJ45/ IE FC RJ45 Plug 180/90 for trailing cable use; PROFINET-compatible; with UL approval; Sold by the meter, max. length 1 000 m; minimum order 20 m IE FC TP Marine Cable 2 x 2 (Type B) 4-core, shielded TP installation cable for connection to IE FC Outlet RJ45/ IE FC RJ45 Plug 180/90 marine certified, Sold by the meter, max. length 1 000 m; minimum order 20 m IE FC Stripping Tool Preadjusted stripping tool for fast stripping of Industrial Ethernet FC cables
		6GK1 901-1BB10-2AA0 6GK1 901-1BB10-2AB0 6GK1 901-1BB10-2AE0 6XV1 840-2AH10 6XV1 840-3AH10 6XV1 840-4AH10 6GK1 901-1GA00

SIMATIC ET 200 distributed I/O

ET 200MP

Interface modules
SIPLUS IM 155-5 PN

Overview



- Interface module for linking the ET 200MP to PROFINET
- Handles data exchange with the PROFINET I/O controller in the PLC
- Integrated 2-port switch for line topology
- Max. 30 I/O modules
- Shortest bus cycle 250 µs
- Linking to the isochronous task of the CPU
- Prioritized fast startup (FSU) with 500 ms (max. 12 I/O modules)
- Media Redundancy Protocol (MRP)
- Shared device on up to two I/O controllers (when configuring using GSD file; depends on the respective configuration tool)
- Omission of SIMATIC memory card (SMC); IM replacement without PG using LLDP

Note:

SIPLUS extreme products are based on Siemens Industry standard products. The contents listed here were taken from the respective standard products. SIPLUS extreme-specific information was added.

Technical specifications

The technical data correspond to those of the based-on modules apart from the values listed in the table:

Based on	6AG1 155-5AA00-7AB0 6ES7 155-5AA00-0AB0
Ambient conditions	
Operating temperature	
• Horizontal mounting position	-40 ... +70 °C
• Vertical mounting position	-40 ... +40 °C
Extended ambient conditions	
• with reference to ambient temperature, air pressure and altitude	Tmin ... Tmax at 1080 hPa ... 795 hPa (-1000 m ... +2000 m) // Tmin ... (Tmax - 10K) at 795 hPa ... 658 hPa (+2000 m ... +3500 m) // Tmin ... (Tmax - 20K) at 658 hPa ... 540 hPa (+3500 m ... +5000 m)
Relative humidity	
• with condensation / maximum / tested in accordance with IEC 60068-2-38	100%; RH incl. condensation/frost (no commissioning in bedewed state)
Resistance	
• to biologically active substances / compliance with EN 60721-3-3	Yes; Class 3B2 mold and fungal spores (except fauna); the supplied plug covers must remain in place on the unused interfaces during operation.
• to chemically active substances / compliance with EN 60721-3-3	Yes; Class 3C4 (RH < 75%) incl. salt spray in accordance with EN 60068-2-52 (severity 3); the supplied plug covers must remain in place on the unused interfaces during operation.
• to mechanically active substances, compliance with EN 60721-3-3	Yes; Class 3S4 incl. sand, dust; the supplied plug covers must remain in place on unused interfaces during operation.

Ordering data

Order No.

SIPLUS IM 155-5 PN interface module

6AG1 155-5AA00-7AB0

(extended temperature range and medial exposure)

IP 20 degree of protection, module width 35 mm, installation on S7-1500 rail

Accessories

See SIMATIC ET 200MP, interface module IM 155-5 PN, page 9/188

SIMATIC ET 200 distributed I/O

ET 200MP

I/O modules

Overview



I/O modules are the interface of the SIMATIC ET 200MP to the process:

- Digital and analog modules provide exactly the inputs/outputs required for each task.
- Technology modules for SIMATIC S7-1500 and ET 200MP
 - With integrated functions for high-speed counting and position detection
 - With integrated inputs and outputs for tasks at the process level and short response times
- Communication modules for data exchange using point-to-point coupling
- Connection system for user-friendly, low-overhead wiring of the S7-1500 and ET 200MP modules
- System power supplies for the S7-1500 and ET 200MP modules

For further information see SIMATIC S7-1500, chapter 4.

Application

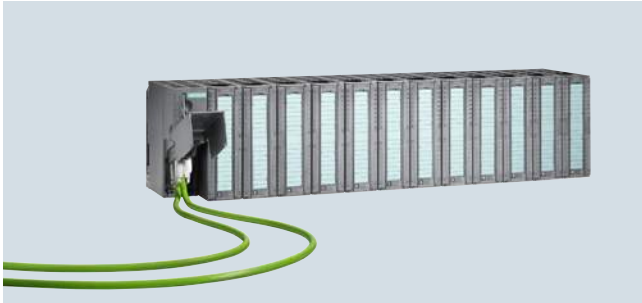

- Modular I/O system with IP20 degree of protection, particularly suitable for user-specific and complex automation tasks
- Can be expanded with S7-300 automation system signal, communication and function modules
- Applicable Ex analog input or output modules with HART optimize the ET 200M for use in process engineering
- Can be used in redundant systems (S7-400H, S7-400F/FH)
- Consists of a PROFIBUS DP or PROFINET interface module IM 153, up to 8 or 12 I/O modules of the S7-300 automation system (structure with bus connection or with active bus modules), and a power supply if applicable
- Modules can be replaced during operation (hot swapping) with the bus modules active
- Transmission rates up to 12 Mbit/s
- Ex approval to Cat. 3 for Zone 2 acc. to ATEX100 a
- Failsafe digital in/outputs as well as analog inputs for safety-oriented signal processing in accordance with PROFIsafe
- Support of modules with expanded user data, e.g. HART modules with HART minor variables

Technical specifications

General technical data ET 200M	
Cables and connections	Screw and spring-loaded connections in permanent wiring
Degree of protection	IP20
Ambient temperature on vertical wall (preferred mounting position)	<ul style="list-style-type: none"> • with horizontal assembly 0 to +60 °C • with other assembly 0 to +40 °C
Relative humidity	5 to 95% (RH stress level 2 according to IEC 1131-2)
Atmospheric pressure	795 to 1080 hPa
Mechanical stress	<ul style="list-style-type: none"> • Vibrations IEC 68, parts 2 – 6: 10 - 57 Hz (const. amplitude 0.075 mm) 57 - 150 Hz (constant acceleration 1 g) • Shock IEC 68, parts 2 – 27 half-sine, 15 g, 11 ms

SIMATIC ET 200 distributed I/O

ET 200M

Interface modules IM 153-1/153-2

Overview



The ET 200M system with various interface modules is available for the decentralized use of S7-300 I/O modules. Depending on the application purpose, the best suited IM in terms of costs and functions can be selected:

IM 153-1 Standard

The IM 153-1 is one reasonably priced variant that is best suited for most applications in the manufacturing environment. It permits the use of up to 8 S7-300 I/O modules.

IM 153-2 High Feature

For higher requirements in manufacturing technology, such as the use of F-technology or the highest performance in conjunction with clock synchronization, the IM 153-2 High Feature is available. This IM is also designed for use with the PCS 7 in the field of manufacturing applications. This IM can be redundantly used and supports typical functions as they are required in the control field. These include, for example, clock synchronization or time stamping with an accuracy of up to 1ms.

Technical specifications

	6ES7 153-1AA03-0XB0	6ES7 153-2BA02-0XB0	6ES7 153-2BA82-0XB0
General information			
Vendor identification (VendorID)	801Dh	801Eh	801Eh
Supply voltage			
24 V DC	Yes	Yes	Yes
permissible range, lower limit (DC)	20.4 V	20.4 V	20.4 V
permissible range, upper limit (DC)	28.8 V	28.8 V	28.8 V
permissible range (ripple included), lower limit (DC)	20.4 V	20.4 V	20.4 V
permissible range (ripple included), upper limit (DC)	28.8 V	28.8 V	28.8 V
External protection for supply cables (recommendation)	not necessary	2.5 A	2.5 A
Mains buffering			
• Mains/voltage failure stored energy time	5 ms	5 ms	5 ms
Input current			
Current consumption, max.	350 mA; at 24 V DC	650 mA	650 mA
Rated value at 24 V DC	625 mA		
Inrush current, typ.	2.5 A	3 A	3 A
I^2t	0.1 A ² ·s	0.1 A ² ·s	0.1 A ² ·s
Output voltage			
Rated value, 5 V DC	Yes	Yes	Yes
Output current			
for backplane bus (5 V DC), max.	1 A	1.5 A	1.5 A
Power losses			
Power loss, typ.	3 W	5.5 W	5.5 W
Address area			
Addressing volume			
• Outputs	128 byte	244 byte	244 byte
• Inputs	128 byte	244 byte	244 byte

Technical specifications (continued)

	6ES7 153-1AA03-0XB0	6ES7 153-2BA02-0XB0	6ES7 153-2BA82-0XB0
Hardware configuration			
Number of modules per DP slave interface, max.	8	12	12
Time stamping			
Accuracy		1 ms; 1ms at up to 8 modules; 10ms at up to 12 modules	1 ms; 1ms at up to 8 modules; 10ms at up to 12 modules
Number of message buffers		15	15
Messages per message buffer		20	20
Number of stampable digital inputs, max.		128; Max. 128 signals/station; max. 32 signals/slot	128; Max. 128 signals/station; max. 32 signals/slot
Time format		RFC 1119	RFC 1119
Time resolution		0.466 ns	0.466 ns
Time interval for transmitting the message buffer if a message is present		1 000 ms	1 000 ms
Time stamp on signal change		rising / falling edge as signal entering or exiting	rising / falling edge as signal entering or exiting
Interfaces			
Interface physics, RS 485	Yes	Yes	Yes
Interface physics, FOC	No	No	No
PROFIBUS DP			
• Node addresses	1 to 125 permitted	1 to 125 permitted	1 to 125 permitted
• Automatic detection of transmission speed	Yes	Yes	Yes
• PROFIBUS DP, output current, max.	90 mA	70 mA	70 mA
• Transmission procedure	RS 485	RS 485	RS 485
• Transmission rate, max.	12 Mbit/s	12 Mbit/s	12 Mbit/s
• SYNC capability	Yes	Yes	Yes
• FREECE capability	Yes	Yes	Yes
• Direct data exchange (slave-to-slave communication)	Yes; Sender	Yes; Sender	Yes; Sender
• PROFIBUS DP	9-pin sub D socket	9-pin sub D	9-pin sub D
1st interface			
DP slave			
• GSD file	(for DPV1) SIEM801D.GSD; SI01801D.GSG	SI04801.GSG	SI0480E.GSG
• Automatic baud rate search	Yes	Yes	Yes
Communication functions			
Bus protocol/transmission protocol	PROFIBUS DP to EN 50170	PROFIBUS DP to EN 50170	PROFIBUS DP to EN 50170
Isolation			
Isolation checked with	Isolation voltage 500 V	Isolation voltage 500 V	Isolation voltage 500 V
Degree and class of protection			
IP20	Yes	Yes	Yes
Ambient conditions			
Operating temperature			
• Min.	0 °C	0 °C	-25 °C
• max.	60 °C	60 °C	60 °C
Air pressure			
• Operating altitude above sea level, max.	3 000 m	3 000 m	3 000 m
Dimensions			
Width	40 mm	40 mm	40 mm
Height	125 mm	125 mm	125 mm
Depth	117 mm	117 mm	117 mm
Weight			
Weight, approx.	360 g	360 g	360 g

SIMATIC ET 200 distributed I/O

ET 200M

Interface modules IM 153-1/153-2

Technical specifications (continued)

6ES7 195-7HD10-0XA0	
Accessories	
belongs to product	ET 200M
Dimensions	
Width	97 mm
Height	92 mm
Depth	30 mm
Weight	
Weight, approx.	133 g

	6ES7 195-7HA00-0XA0	6ES7 195-7HB00-0XA0	6ES7 195-7HC00-0XA0
Dimensions			
Width	97 mm	97 mm	97 mm
Height	92 mm	92 mm	92 mm
Depth	30 mm	30 mm	30 mm
Weight			
Weight, approx.	111 g	140 g	127 g

Ordering data

	Order No.
IM 153-1 interface module Slave interface for connecting an ET 200M to PROFIBUS DP • Standard temperature range	6ES7 153-1AA03-0XB0
IM 153-2 interface module Slave interface for connecting an ET 200M to PROFIBUS DP; also for use in redundant systems • High Feature • High Feature with extended temperature range	6ES7 153-2BA02-0XB0 6ES7 153-2BA82-0XB0
Active IM 153 /IM 153 bus module For two IM 153-2 High Feature modules for designing redundant systems	6ES7 195-7HD10-0XA0
Bus module for ET 200M • To accommodate a power supply and an IM 153 module for the hot-swapping function during RUN, incl. bus module cover • To accommodate two 40-mm wide I/O modules for the hot-swapping function • To accommodate one 80-mm wide I/O module for the hot-swapping function	6ES7 195-7HA00-0XA0 6ES7 195-7HB00-0XA0 6ES7 195-7HC00-0XA0
ET 200M redundancy bundle Comprising two IM 153-2 High Feature modules and one IM 153/IM 153 bus module	6ES7153-2AR03-0XA0

Order No.

Accessories

PROFIBUS bus connector

90° outgoing cable, terminating resistor with disconnecting function, up to 12 Mbit/s, FastConnect

Without PG interface

- 1 unit
- 100 units

6ES7 972-0BA52-0XA0
6ES7 972-0BA52-0XB0

With PG interface

- 1 unit
- 100 units

6ES7 972-0BB52-0XA0
6ES7 972-0BB52-0XB0

SIMATIC DP DIN rail for ET 200M

Accommodates up to 5 bus modules; for hot-swapping function

- Length: 483 mm (19")
- Length: 530 mm
- Length: 620 mm
- Length: 2000 mm

6ES7 195-1GA00-0XA0
6ES7 195-1GF30-0XA0
6ES7 195-1GG30-0XA0
6ES7 195-1GC00-0XA0

SIMATIC S7-300 mounting rail

- Length: 160 mm
- Length: 480 mm (19")
- Length: 530 mm
- Length: 830 mm
- Length: 2000 mm

6ES7 390-1AB60-0AA0
6ES7 390-1AE80-0AA0
6ES7 390-1AF30-0AA0
6ES7 390-1AJ30-0AA0
6ES7 390-1BC00-0AA0

S7 Manual Collection

6ES7 998-8XC01-8YE0

Electronic manuals on DVD, multi-language:
S7-200, TD 200, S7-300, M7-300, C7, S7-400, M7-400, STEP 7, Engineering Tools, Runtime Software, SIMATIC DP (Distributed I/O), SIMATIC HMI (Human Machine Interface), SIMATIC NET (Industrial Communication)

S7 Manual Collection, update service for 1 year

6ES7 998-8XC01-8YE2

Scope of delivery:
Current DVD "S7 Manual Collection" and the three subsequent updates

Overview



- To connect ET 200M to PROFINET IO (via copper line, RJ45) as an IO device
- 2 versions:
 - IM 153-4 PN STANDARD
 - IM 153-4 PN HIGH FEATURE: supports, in contrast to the STANDARD version, the operation of PROFI-safe F and HART modules
- Integrated 2-port switch
- 12 modules per station
- Usable I/O quantity structure: 192 bytes each
- Active bus backplane to hot-swap modules available as an option
- Baud rate 10 Mbit/s / 100 Mbit/s (autonegotiation / full duplex)
- I&M functions in accordance with PROFIBUS International guideline order no. 3.502, Version V1.1

Note:

Micro Memory Card with at least 64 KB required if not all the stations in the network support LLDP (Link Layer Discovery Protocol; proximity detection).

Technical specifications

	6ES7 153-4AA01-0XB0	6ES7 153-4BA00-0XB0
General information		
Vendor identification (VendorID)	002AH	002AH
Device identifier (DeviceID)	0302H	0302H
Supply voltage		
24 V DC	Yes	Yes
permissible range, lower limit (DC)	20.4 V	20.4 V
permissible range, upper limit (DC)	28.8 V	28.8 V
permissible range (ripple included), lower limit (DC)	20.4 V	18.5 V
permissible range (ripple included), upper limit (DC)	28.8 V	30.2 V
External protection for supply cables (recommendation)	In a construction with grounded reference potential, a fuse is necessary for redundant interface modules (Recommendation: 2.5 A)	In a construction with grounded reference potential, a fuse is necessary for redundant interface modules (Recommendation: 2.5 A)
Mains buffering		
• Mains/voltage failure stored energy time	5 ms	5 ms
Input current		
Current consumption, max.	600 mA	600 mA
Inrush current, typ.	4 A	4 A
I^2t	0.09 A ² ·s	0.09 A ² ·s
Output voltage		
Rated value, 5 V DC	Yes	Yes
Output current		
for backplane bus (5 V DC), max.	1.5 A	1.5 A
Power losses		
Power loss, typ.	6 W; Typical	6 W; Typical
Address area		
Addressing volume		
• Outputs	192 byte	192 byte
• Inputs	192 byte	672 byte; Extended HART user data
Hardware configuration		
Number of modules per DP slave interface, max.	12	12

SIMATIC ET 200 distributed I/O

ET 200M

Interface modules IM 153-4 PN

Technical specifications (continued)

	6ES7 153-4AA01-0XB0	6ES7 153-4BA00-0XB0
Communication functions		
Bus protocol/transmission protocol	PN IO	PN IO
Interrupts/diagnostics/ status information		
Diagnostics indication LED		
• Connection to network LINK (green)	Yes	Yes
• Transmit/receive RX/TX (yellow)	Yes	Yes
Isolation		
Isolation checked with	500 V DC	Between Profinet and 24 V supply: 1500 V AC Between functional grounding and 24 V supply: 500 V DC
Degree and class of protection		
IP20	Yes	Yes
Ambient conditions		
Operating temperature		
• Min.	0 °C	0 °C
• max.	60 °C	60 °C
Air pressure		
• Operating altitude above sea level, max.	2 000 m	2 000 m
Dimensions		
Width	40 mm	40 mm
Height	125 mm	125 mm
Depth	118 mm	118 mm
Weight		
Weight, approx.	215 g; approx.	215 g

Ordering data

Ordering data	Order No.	Order No.
IM 153-4 PN interface module		
I/O device to connect an ET 200M to PROFINET		
Standard	6ES7 153-4AA01-0XB0	
High Feature	6ES7 153-4BA00-0XB0	
Accessories		
Bus modules for ET 200M		
• To accommodate a power supply and an IM 153 module for the hot-swapping function during RUN, incl. bus module cover	6ES7 195-7HA00-0XA0	
• To accommodate two 40-mm wide I/O modules for the hot-swapping function	6ES7 195-7HB00-0XA0	
• To accommodate one 80-mm wide I/O module for the hot-swapping function	6ES7 195-7HC00-0XA0	
SIMATIC Micro Memory Card		
64 KB ¹⁾	6ES7 953-8LF20-0AA0	
SIMATIC DP DIN rail for ET 200M		
Accommodates up to 5 bus modules; for hot-swapping function		
• Length: 483 mm (19")	6ES7 195-1GA00-0XA0	
• Length: 530 mm	6ES7 195-1GF30-0XA0	
• Length: 620 mm	6ES7 195-1GG30-0XA0	
• Length: 2 000 mm	6ES7 195-1GC00-0XA0	
SIMATIC S7-300 mounting rail		
Length: 160 mm	6ES7 390-1AB60-0AA0	
Length: 480 mm (19")	6ES7 390-1AE80-0AA0	
Length: 530 mm	6ES7 390-1AF30-0AA0	
Length: 830 mm	6ES7 390-1AJ30-0AA0	
Length: 2000 mm	6ES7 390-1BC00-0AA0	
S7 Manual Collection		6ES7 998-8XC01-8YE0
Electronic manuals on DVD, multi-language: S7-200, TD 200, S7-300, M7-300, C7, S7-400, M7-400, STEP 7, Engineering Tools, Runtime Software, SIMATIC DP (Distributed I/O), SIMATIC HMI (Human Machine Interface), SIMATIC NET (Industrial Communication)		
S7 Manual Collection update service for 1 year		6ES7 998-8XC01-8YE2
Scope of delivery: Current DVD "S7 Manual Collection" and the three subsequent updates		
Industrial Ethernet FC RJ45 Plug 180		
RJ45 plug connector for Industrial Ethernet with a rugged metal housing and integrated insulation displacement contacts for connecting Industrial Ethernet FC installation cables; with 180° cable outlet		
1 unit		6GK1 901-1BB10-2AA0
10 units		6GK1 901-1BB10-2AB0
50 units		6GK1 901-1BB10-2AE0
Industrial Ethernet FastConnect installation cables		
• FastConnect standard cable		6XV1 840-2AH10
• FastConnect trailing cable		6XV1 840-3AH10
• FastConnect marine cable		6XV1 840-4AH10
Industrial Ethernet FastConnect Stripping Tool		6GK1 901-1GA00

¹⁾ To operate the IM153-4, an MMC is required with at least 64 KB memory. Cards with higher memory capacity may also be used.

Overview

Note:

SIPLUS extreme products are based on Siemens Industry standard products. The contents listed here were taken from the respective standard products. SIPLUS extreme specific information was added.

	SIPLUS IM 153-1	SIPLUS IM 153-2	SIPLUS IM 153-2
Order No.	6AG1 153-1AA03-2XB0	6AG1 153-2BA02-2XY0	6AG1 153-2BA02-7XB0
Order number based on	6ES7 153-1AA03-0XB0	6ES7 153-2BA02-0XB0	6ES7 153-2BA02-0XB0
Ambient temperature range	-40 ... +70 °C Start-up temperature -25 °C	-25 ... +60 °C	-40 ... +70 °C Start-up temperature -25 °C
Compliant with the standards for electronic equipment used on rolling stock (EN 50155, temperature T1, category 1).	No	Yes	No
Conformal coating	Coating of the printed circuit boards and the electronic components		
Technical data	The technical data of the standard product applies except for the ambient conditions.		
SIPLUS bus module	for accommodating a PS and an IM 153	for accommodating two 40 mm wide I/O modules	
Order No.	6AG1 195-7HA00-2XA0	6AG1 195-7HB00-7XA0	
Order number based on	6ES7 195-7HA00-0XA0	6ES7 195-7HB00-0XA0	
Ambient temperature range	-40 ... +70 °C	-40 ... +70 °C	
Compliant with the standards for electronic equipment used on rolling stock (EN 50155, temperature T1, category 1).	No	Yes	
Conformal coating	Coating of the printed circuit boards and the electronic components		
Technical data	The technical data of the standard product applies except for the ambient conditions.		
SIPLUS bus module	for accommodating an 80 mm module	for accommodating two IM 153-2	
Order No.	6AG1 195-7HC00-2XA0	6AG1 195-7HD10-2XA0	
Order number based on	6ES7 195-7HC00-0XA0	6ES7 195-7HD10-0XA0	
Ambient temperature range	-40 ... +70 °C	-40 ... +70 °C	
Compliant with the standards for electronic equipment used on rolling stock (EN 50155, temperature T1, category 1).	No	Yes	
Conformal coating	Coating of the printed circuit boards and the electronic components		
Technical data	The technical data of the standard product applies except for the ambient conditions.		

SIMATIC ET 200 distributed I/O

ET 200M

SIPLUS interface modules SIPLUS IM 153-1/153-2

Overview (continued)

Ambient conditions

Relative humidity	100%, condensation/frost permissible. No commissioning if condensation present.
Biologically active substances, compliance with EN 60721-3-3	Class 3B2 mold and fungal spores (excluding fauna). The supplied plug covers must remain in place over the unused interfaces during operation!
Chemically active substances, compliance with EN 60721-3-3	Class 3C4 incl. salt spray in accordance with EN60068-2-52 (degree of severity 3). The supplied plug covers must remain in place over the unused interfaces during operation!
Mechanically active substances, compliance with EN 60721-3-3	Class 3S4 incl. sand, dust. The supplied plug covers must remain in place over the unused interfaces during operation!
Air pressure (depending on the highest positive temperature range specified)	1 080 ... 795 hPa (-1 000 ... +2 000 m) see ambient temperature range 795 ... 658 hPa (+2 000 ... +3 500 m) derating 10 K 658 ... 540 hPa (+3 500 ... +5 000 m) derating 20 K

For technical documentation on SIPLUS, see:
<http://www.siemens.com/siplus-extreme>

Ordering data

Order No.

IM 153-1 interface module

Slave interface for connecting an ET 200M to PROFIBUS DP

- Standard temperature range

6AG1 153-1AA03-2XB0

IM 153-2 interface module

Slave interface for connecting an ET 200M to PROFIBUS DP; also for use in redundant systems

- High Feature, -25 ... +60 °C
- High Feature, -40 ... +70 °C

6 AG1 153-2BA02-2XY0
6 AG1 153-2BA02-7XB0

Active IM 153/IM 153 bus module

For two IM 153-2 High Feature modules for designing redundant systems

6 AG1 195-7HD10-2XA0

Bus module for ET 200M

- To accommodate a power supply and an IM 153 for the hot-swapping function during RUN, incl. bus module cover
- To accommodate two 40 mm wide I/O modules for the hot-swapping function
- To accommodate one 80 mm wide I/O module for the hot swapping function

6AG1 195-7HA00-2XA0

6AG1 195-7HB00-7XA0

6AG1 195-7HC00-2XA0

Accessories

See SIMATIC ET 200M
IM 153-1/153-2, page 9/194

SIMATIC ET 200 distributed I/O

ET 200M

SIPLUS interface modules SIPLUS IM 153-4 PN IO

Overview



- For connection of ET 200M as IO Device to PROFINET IO (copper, RJ-45)
- 2 versions:
 - IM 153-4 PN STANDARD
 - IM 153-4 PN HIGH FEATURE: additionally to the STANDARD version, operation of PROFI-safe F and HART modules
- Integrated 2-port switch
- 12 modules per station
- Usable I/O quantity structure: 192 bytes each
- Active backplane bus for hot swapping of modules optionally available
- Baud rate 10 Mbit/s / 100 Mbit/s (Autonegotiation/Full Duplex)
- I&M functions according to PNO-Guideline Order-No. 3.502, Version V1.1

Notes:

Micro Memory Card with min. 64 KB required if not all participants in the network support LLDP (Link Layer Discovery Protocol; neighbor detection).

SIPLUS extreme products are based on Siemens Industry standard products. The contents listed here were taken from the respective standard products. SIPLUS extreme-specific information was added.

SIPLUS ET 200 M IM 153-4 PN	
Order number	6AG1 153-4AA01-7XB0
Order No. based on	6ES7 153-4AA01-0XB0
Ambient temperature range	-25 °C ... + 70 °C
Conformal coating	Coating of the printed circuit boards and the electronic components
Technical data	The technical data of the standard product applies except for the environmental conditions.
Ambient conditions	
Relative humidity	5 ... 100 % Condensation permissible
Biologically active substances	Conformity with EN 60721-3-3, Class 3B2 mold and fungal spores (except fauna)
Chemically active substances	Conformity with EN 60721-3-3, Class 3C4 incl. salt mist and ISA-S71.04 severity level G1; G2; G3; GX ¹⁾²⁾
Mechanically active substances	Conformity with EN 60721-3-3, Class 3S4 including conductive sand, dust ²⁾
Air pressure (depending on the highest positive temperature range specified)	1080 ... 795 hPa (-1000 ... +2000 m) See ambient temperature range 795 ... 658 hPa (+2000 ... +3500 m) derating 10 K 658 ... 540 hPa (+3500 ... +5000 m) derating 20 K

¹⁾ ISA-S71.04 severity level GX: Long-term load: SO₂ < 4.8 ppm; H₂S < 9.9 ppm; Cl < 0.2 ppm; HCl < 0.66 ppm; HF < 0.12 ppm; NH < 49 ppm; O₃ < 0.1 ppm; NOX < 5.2 ppm
Limit value (max. 30 min/d): SO₂ < 17.8 ppm; H₂S < 49.7 ppm; Cl < 1.0 ppm; HCl < 3.3 ppm; HF < 2.4 ppm; NH < 247 ppm; O₃ < 1.0 ppm; NOX < 10.4 ppm

²⁾ The supplied plug covers must remain in place over the unused interface when operated in atmospheres containing corrosive gases!

The technical documentation on SIPLUS can be found here:
<http://www.siemens.com/siplus-extreme>

Ordering data	Order No.
SIPLUS ET 200 M interface connection IM 153-4 PN (extended temperature range and medial exposure) IO Device to connect an ET 200M to PROFINET ¹⁾	6AG1 153-4AA01-7XB0
Accessories	See SIMATIC ET 200M interface module IM 153-4 PN, page 9/196

¹⁾ To operate the IM153-4, an MMC is required with at least 64 KB memory. Cards with higher memory capacity may also be used.

SIMATIC ET 200 distributed I/O

ET 200M

I/O modules Digital/analog modules

Overview Digital modules



- Digital inputs/outputs
- For flexible adaptation of the controller to the respective task
- For connecting digital sensors and actuators

For further information, see SIMATIC S7-300, chapter 5.

Overview Analog modules



- Analog inputs and outputs
- For solving even more complex tasks with analog process signals
- For connecting analog actuators and sensors without additional measuring amplifiers

For further information, see SIMATIC S7-300, chapter 5.

Overview



- Can only be plugged into ET 200M with IM 153-2 and IM 153-2 FO
- 8 AI HART
- Redundancy switching
- Firmware update
- HART minor variables

Technical specifications

6ES7 331-7TF01-0AB0	
Supply voltage	
Load voltage L+	24 V
• Rated value (DC)	Yes
• Reverse polarity protection	Yes
Input current	
from load voltage L+ (without load), max.	20 mA
from backplane bus 5 V DC, max.	120 mA
Power losses	
Power loss, typ.	1.5 W
Analog inputs	
Number of analog inputs	8
permissible input current for current input (destruction limit), max.	40 mA
Input ranges (rated values), currents	Yes
• 0 to 20 mA	Yes
Cable length	
• Cable length, shielded, max.	800 m
Analog value creation	
Measurement principle	Sigma Delta
Integrations and conversion time/ resolution per channel	
• Resolution with overrange (bit including sign), max.	16 bit
• Integration time, parameterizable	Yes
• Integration time, ms	20 ms@50 Hz/ 16.6 ms@60 Hz/ 100 ms@100 Hz
• Interference voltage suppression for interference frequency f1 in Hz	60 / 50 / 10 Hz
Encoder	
Connection of signal encoders	
• for current measurement as 2-wire transducer	Yes
• for current measurement as 4-wire transducer	Yes

6ES7 331-7TF01-0AB0	
Errors/accuracies	
Operational limit in overall temperature range	
• Current, relative to input area	+/- 0,15 %
Basic error limit (operational limit at 25 °C)	
• Current, relative to input area	+/- 0,1 %
Isochronous mode	
Isochronous operation (application synchronized up to terminal)	No
Interrupts/diagnostics/ status information	
Alarms	
• Diagnostic alarm	Yes
• Limit value alarm	Yes
Diagnostic messages	
• Diagnostic information readable	Yes
Galvanic isolation	
Galvanic isolation analog inputs	
• between the channels	No
• between the channels, in groups of	8
• between the channels and the backplane bus	Yes
Isolation	
Isolation checked with	500
Connection method	
required front connector	20-pin
Dimensions	
Width	40 mm
Height	125 mm
Depth	117 mm
Weight	
Weight, approx.	205 g

SIMATIC ET 200 distributed I/O

ET 200M

I/O modules

Analog input module with HART

Ordering data	Order No.		Order No.
SM 331 HART analog input module 8 inputs, 0/4 – 20 mA, HART for ET 200M with IM 153-2 interface module	6ES7 331-7TF01-0AB0	Label cover (10 units, spare part) for signal modules (not 32-channel modules), function modules and CPU 312 IFM	6ES7 392-2XY00-0AA0
Accessories Front connectors <ul style="list-style-type: none"> • 20-pin, with screw contacts <ul style="list-style-type: none"> - 1 unit - 100 units • 20-pin, with spring contacts <ul style="list-style-type: none"> - 1 unit - 100 units 	6ES7 392-1AJ00-0AA0 6ES7 392-1AJ00-1AB0 6ES7 392-1BJ00-0AA0 6ES7 392-1BJ00-1AB0	Labeling strips (10 units, spare part) for signal modules (not 32-channel modules), function modules and CPU 312 IFM	6ES7 392-2XX00-0AA0
LK 393 cable guide Mandatory for operation in hazardous areas	6ES7 393-4AA00-0AA0	Labeling sheets for machine printing for modules with 20-pin front connector, DIN A4, for printing with laser printer; 10 units petrol light beige yellow red	6ES7 392-2AX00-0AA0 6ES7 392-2BX00-0AA0 6ES7 392-2CX00-0AA0 6ES7 392-2DX00-0AA0
SIMATIC DP mounting rail for ET 200M For mounting of up to 5 bus modules for <ul style="list-style-type: none"> • Length: 483 mm (19") • Length: 530 mm 	6ES7 195-1GA00-0XA0 6ES7 195-1GF30-0XA0		
SIMATIC S7-300 mounting rail <ul style="list-style-type: none"> • Length: 160 mm • Length: 480 mm (19") • Length: 530 mm • Length: 830 mm • Length: 2000 mm 	6ES7 390-1AB60-0AA0 6ES7 390-1AE80-0AA0 6ES7 390-1AF30-0AA0 6ES7 390-1AJ30-0AA0 6ES7 390-1BC00-0AA0		

Overview



- For plugging into ET 200M exclusively with IM 153-2 and IM 153-2 FO
- 8 AO HART
- Redundancy switching
- Firmware update
- HART minor variables

Technical specifications

6ES7 332-8TF01-0AB0	
Supply voltage	
Load voltage L+	
• Rated value (DC)	24 V
Input current	
from load voltage L+ (without load), max.	350 mA
from backplane bus 5 V DC, max.	110 mA
Power losses	
Power loss, typ.	6 W
Analog outputs	
Number of analog outputs	8
Current output, no-load voltage, max.	24 V
Output ranges, current	
• 0 to 20 mA	Yes
• -20 to +20 mA	No
• 4 to 20 mA	Yes
Load impedance (in rated range of output)	
• with current outputs, max.	750 Ω
• with current outputs, inductive load, max.	10 mH
Cable length	
• Cable length, shielded, max.	800 m
Analog value creation	
Integrations and conversion time/ resolution per channel	
• Resolution with overrange (bit including sign), max.	16 bit
Settling time	
• for resistive load	0.1 ms
• for inductive load	0.5 ms

6ES7 332-8TF01-0AB0	
Errors/accuracies	
Operational limit in overall temperature range	
• Current, relative to output area	+/- 0,2 %
Basic error limit (operational limit at 25 °C)	
• Current, relative to output area	+/- 0,1 %
Interrupts/diagnostics /status information	
Substitute values connectable	Yes
Alarms	
• Diagnostic alarm	Yes
Diagnostic messages	
• Diagnostic information readable	Yes
Galvanic isolation	
Galvanic isolation analog outputs	
• between the channels and the backplane bus	Yes
Isolation	
Isolation checked with	500 V DC
Connection method	
required front connector	20-pin
Dimensions	
Width	40 mm
Height	125 mm
Depth	117 mm
Weight	
Weight, approx.	220 g

SIMATIC ET 200 distributed I/O

ET 200M

I/O modules

Analog output module with HART

Ordering data	Order No.	Order No.	
SM 332 HART analog output module HART analog output, 8 outputs, 0/4 – 20 mA, HART for ET 200M with IM 153-2	6ES7 332-8TF01-0AB0	S7 Manual Collection Electronic manuals on DVD, multi-language: S7-200, TD 200, S7-300, M7-300, C7, S7-400, M7-400, STEP 7, Engineering Tools, Runtime Software, SIMATIC DP (Distributed I/O), SIMATIC HMI (Human Machine Interface), SIMATIC NET (Industrial Communication)	6ES7 998-8XC01-8YE0
Accessories Front connector <ul style="list-style-type: none"> • 20-pin, with screw contacts <ul style="list-style-type: none"> - 1 item - 100 items • 20-pin, with spring-loaded terminals <ul style="list-style-type: none"> - 1 item - 100 items 	6ES7 392-1AJ00-0AA0 6ES7 392-1AJ00-1AB0 6ES7 392-1BJ00-0AA0 6ES7 392-1BJ00-1AB0	S7 Manual Collection update service for 1 year Scope of delivery: Current DVD "S7 Manual Collection" and the three subsequent updates	6ES7 998-8XC01-8YE2
LK 393 cable guide Mandatory for operation in hazardous areas	6ES7 393-4AA00-0AA0	Labeling sheets for machine printing for modules with 20-pin front connector, DIN A4, for printing with laser printer; 10 units petrol light beige yellow red	6ES7 392-2AX00-0AA0 6ES7 392-2BX00-0AA0 6ES7 392-2CX00-0AA0 6ES7 392-2DX00-0AA0
SIMATIC DP mounting rail for ET 200M For mounting of up to 5 bus modules for <ul style="list-style-type: none"> • Length: 483 mm • Length: 530 mm 	6ES7 195-1GA00-0XA0 6ES7 195-1GF30-0XA0		
SIMATIC S7-300 mounting rail <ul style="list-style-type: none"> • Length: 160 mm • Length: 480 mm • Length: 530 mm • Length: 830 mm • Length: 2000 mm 	6ES7 390-1AB60-0AA0 6ES7 390-1AE80-0AA0 6ES7 390-1AF30-0AA0 6ES7 390-1AJ30-0AA0 6ES7 390-1BC00-0AA0		
Label cover (10 units, spare part) for signal modules (not 32-channel modules), function modules and CPU 312 IFM	6ES7 392-2XY00-0AA0		
Labeling strips (10 units, spare part) for signal modules (not 32-channel modules), function modules and CPU 312 IFM	6ES7 392-2XX00-0AA0		

Overview



- For connecting HART devices in hazardous areas
- Can only be plugged into ET 200M
- 2 AI HART, Ex
- 2 inputs in 2 channel groups (single-channel isolation)
- Measurement type/range can be selected for each channel
- Diagnostics and diagnostic alarm parameterizable

Technical specifications

6ES7 331-7TB00-0AB0	
Supply voltage	
Load voltage L+	
• Rated value (DC)	24 V
• Reverse polarity protection	Yes
Input current	
from backplane bus 5 V DC, max.	100 mA
from supply voltage L+, max.	180 mA
Output voltage	
Power supply to the transmitters	
• present	Yes
• Rated value (DC)	15 V; at 22 mA
• short-circuit proof	Yes; approx. 30 mA
• No-load voltage (DC)	29.6 V
Power losses	
Power loss, typ.	4.5 W
Analog inputs	
Number of analog inputs	2
permissible input current for current input (destruction limit), max.	40 mA
Input ranges	
• Current	Yes
Input ranges (rated values), currents	
• 0 to 20 mA	Yes
• Input resistance (0 to 20 mA)	50 Ω
• 4 to 20 mA	Yes
• Input resistance (4 to 20 mA)	50 Ω
Cable length	
• Cable length, shielded, max.	400 m
Analog value creation	
Measurement principle	Sigma Delta
Integrations and conversion time/resolution per channel	
• Resolution with overrange (bit including sign), max.	16 bit; 10 to 15 bits + sign
• Integration time, parameterizable	Yes
• Integration time, ms	2.5 / 16.67 / 20 / 100 ms
• Basic conversion time, including integration time, ms	2.5 / 16.67 / 20 / 100 (1 channel enabled); 7.5 / 50 / 60 / 300 (2 channels enabled)
• Interference voltage suppression for interference frequency f1 in Hz	10 / 50 / 60 / 400 Hz

6ES7 331-7TB00-0AB0	
Encoder	
Connection of signal encoders	
• for current measurement as 2-wire transducer	Yes
• for current measurement as 4-wire transducer	Yes
Errors/accuracies	
Linearity error (relative to input area)	+/- 0.01 %
Temperature error (relative to input area)	+/- 0.01 %
Crosstalk between the inputs, min.	130 dB
Repeat accuracy in settled status at 25 °C (relative to input area)	+/- 0.05 %
Operational limit in overall temperature range	
• Current, relative to input area	+/- 0,45 %; From 0/4 to 20 mA
Basic error limit (operational limit at 25 °C)	
• Current, relative to input area	+/- 0,1 %; From 0/4 to 20 mA
Interference voltage suppression for $f = n \times (f1 \pm 1\%)$, f1 = interference frequency	
• Series mode interference (peak value of interference < rated value of input range), min.	60 dB
• Common mode interference, min.	130 dB
Interrupts/diagnostics/status information	
Alarms	
• Diagnostic alarm	Yes; Parameterizable
• Limit value alarm	Yes; Parameterizable, channels 0 and 1
Diagnostic messages	
• Diagnostic functions	Yes; can be set in parameters, red LED, alarm message
• Diagnostic information readable	Yes
• Overrange	Yes; Red LED, signal
• Wire break in signal transmitter cable	Yes; Red LED, signal
• Short circuit of the signal encoder cable	Yes; Red LED, signal
• HART communication active	Yes; green LED (H)
Diagnostics indication LED	
• Group error SF (red)	Yes
• Channel error indicator F (red)	Yes

SIMATIC ET 200 distributed I/O

ET 200M

I/O modules

Ex-analog input module with HART

Technical specifications (continued)

6ES7 331-7TB00-0AB0	
Ex(i) characteristics	
Module for Ex(i) protection	Yes
Max. values of input circuits (per channel)	
• Co (permissible external capacity), max.	62 nF
• Io (short-circuit current), max.	96.1 mA
• Lo (permissible external inductivity), max.	3 mH
• Po (power of load), max.	511 mW
• Uo (output no-load voltage), max.	26 V
• Um (fault voltage), max.	250 V; DC
• Ta (permissible ambient temperature), max.	0.6 °C
Galvanic isolation	
between the channels and backplane bus	Yes
Galvanic isolation analog inputs	
• Galvanic isolation analog inputs	Yes
Galvanic isolation analog outputs	
• between the channels	Yes
• between the channels and the load voltage L+	Yes
Permissible potential difference	
between the inputs (UCM)	60 V DC/30 V AC
Isolation	
tested with	
• Channels against backplane bus and load voltage L+	1500 V AC
• Channels among one another	1500 V AC
• Load voltage L+ against backplane bus	500 V DC
Standards, approvals, certificates	
FM approval	Available soon
Use in hazardous areas	
• Type of protection acc. to EN 50020 (CENELEC)	[EEx ib] IIC
• Type of protection acc. to FM	Class I, Division 2, Group A, B, C, D T4; Class I, Zone 2, Group IIC T4
• Test number KEMA	KEMA 97; ATEX3039 X
• Type of protection acc. to KEMA	II3 (2) G Eex nA [ib] IIC T4
Ambient conditions	
Operating temperature	
• max.	60 °C
Dimensions	
Width	40 mm
Height	125 mm
Depth	120 mm
Weight	
Weight, approx.	260 g

Ordering data

Order No.

SM 331 HART analog input module	6ES7 331-7TB00-0AB0
2 inputs, 0/4 – 20 mA, HART for ET 200M with IM 153-2 interface module	
Accessories	
Front connector¹⁾	
20-pin, with screw contacts	
• 1 unit	6ES7 392-1AJ00-0AA0
• 100 units	6ES7 392-1AJ00-1AB0
LK 393 cable guide	6ES7 393-4AA00-0AA0
Mandatory for operation in hazardous areas	
SIMATIC DP mounting rail for ET 200M	
For mounting of up to 5 bus modules for	
• Length: 483 mm	6ES7 195-1GA00-0XA0
• Length: 530 mm	6ES7 195-1GF30-0XA0
SIMATIC S7-300 mounting rail	
• Length: 160 mm	6ES7 390-1AB60-0AA0
• Length: 480 mm (19")	6ES7 390-1AE80-0AA0
• Length: 530 mm	6ES7 390-1AF30-0AA0
• Length: 830 mm	6ES7 390-1AJ30-0AA0
• Length: 2000 mm	6ES7 390-1BC00-0AA0
Label cover	6ES7 392-2XY00-0AA0
(10 units, spare part) for signal modules (not 32-channel modules), function modules and CPU 312 IFM	
Labeling strips	6ES7 392-2XX00-0AA0
(10 units, spare part) for signal modules (not 32-channel modules), function modules and CPU 312 IFM	
Labeling sheets for machine printing	
for modules with 20-pin front connector, DIN A4, for printing with laser printer; 10 units	
petrol	6ES7 392-2AX00-0AA0
light beige	6ES7 392-2BX00-0AA0
yellow	6ES7 392-2CX00-0AA0
red	6ES7 392-2DX00-0AA0

¹⁾ A connector with spring-loaded terminals cannot be used if the cable guide is used.

Overview



- For using HART devices in hazardous areas.
- Can only be plugged into ET 200M
- 2 AO HART, Ex
- 2 current outputs in 2 channel groups (single-channel isolation)
- Output type and range can be selected for each channel
- Diagnostics and diagnostic alarm parameterizable
- Read-back capability of the analog outputs

Technical specifications

6ES7 332-5TB00-0AB0	
Supply voltage	
Load voltage L+	24 V
• Rated value (DC)	Yes
• Reverse polarity protection	Yes
Input current	
from backplane bus 5 V DC, max.	100 mA
from supply voltage L+, max.	150 mA
Power losses	
Power loss, typ.	3.5 W
Analog outputs	
Number of analog outputs	2
Voltage output, short-circuit protection	Yes
Current output, no-load voltage, max.	19 V
Cycle time (all channels) max.	5 ms
Output ranges, current	
• 0 to 20 mA	Yes
• 4 to 20 mA	Yes
Connection of actuators	
• for current output 2-conductor connection	Yes
Load impedance (in rated range of output)	
• with current outputs, max.	650 Ω
• with current outputs, inductive load, max.	7.5 mH
Destruction limits against externally applied voltages and currents	
• Voltages at the outputs towards MANA	max. 17 V / -0.5 V
• Current, max.	60 mA / -1 A
Cable length	
• Cable length, shielded, max.	400 m
Analog value creation	
Integrations and conversion time/resolution per channel	
• Resolution with overrange (bit including sign), max.	12 bit; Output value; 8 bit (+ sign) read back value
• Conversion time (per channel)	40 ms
Settling time	
• for resistive load	2.5 ms
• for capacitive load	4 ms
• for inductive load	2.5 ms

6ES7 332-5TB00-0AB0	
Errors/accuracies	
Output ripple (based on output area, bandwidth 0 to 50 kHz)	+/- 0.02 %
Linearity error (relative to output area)	+/- 0.03 %
Temperature error (relative to output area)	+/- 0.01 %
Crosstalk between the outputs, min.	130 dB
Repeat accuracy in settled status at 25 °C (relative to output area)	+/- 0.005 %
Operational limit in overall temperature range	
• Current, relative to output area	+/- 0.55 %
Basic error limit (operational limit at 25 °C)	
• Current, relative to output area	+/- 0.15 %
Interrupts/diagnostics/status information	
Substitute values connectable	Yes; Parameterizable
Alarms	
• Diagnostic alarm	Yes; Parameterizable
Diagnostic messages	
• Diagnostic functions	Yes; Parameterizable
• Diagnostic information readable	Yes
• Diagnostics	Yes
• Overrange	Yes
• Wire break	Yes; as of output value > 0.5 mA
• Wire break in actuator cable	Yes
• HART communication active	Yes; green LED (H)
Diagnostics indication LED	
• Group error SF (red)	Yes; Additional group message per channel
• Channel error indicator F (red)	Yes; per channel

SIMATIC ET 200 distributed I/O

ET 200M

I/O modules

Ex-analog output module with HART

Technical specifications (continued)

6ES7 332-5TB00-0AB0	
Ex(i) characteristics	
Module for Ex(i) protection	Yes
Max. values of output circuits (per channel)	
• Co (permissible external capacity), max.	230 nF
• Io (short-circuit current), max.	66 mA
• Lo (permissible external inductivity), max.	7.5 mH
• Po (power of load), max.	506 mW
• Uo (output no-load voltage), max.	19 V
• Um (fault voltage), max.	60 V; DC
• Ta (permissible ambient temperature), max.	60 °C
Galvanic isolation	
between the channels and backplane bus	Yes
Galvanic isolation analog outputs	
• Galvanic isolation analog outputs	Yes
• between the channels	Yes
• between the channels and the load voltage L+	Yes
Permissible potential difference	
between the outputs (UCM)	60 V DC/30 V AC
between M internally and the outputs	60 V DC/30 V AC
Isolation	
tested with	
• Channels against backplane bus and load voltage L+	1500 V AC
• Channels among one another	1500 V AC
• Load voltage L+ against backplane bus	500 V DC
Standards, approvals, certificates	
FM approval	Available soon
Use in hazardous areas	
• Type of protection acc. to EN 50020 (CENELEC)	[EEx ib] IIC
• Type of protection acc. to FM	Class I, Division 2, Group A, B, C, D T4; Class I, Zone 2, Group IIC T4 97 ATEX 2359 X
• Test number KEMA	II3 (2) G Eex nA [ib] IIC T4
• Type of protection acc. to KEMA	
Dimensions	
Width	40 mm
Height	125 mm
Depth	120 mm
Weight	
Weight, approx.	280 g

Ordering data

Order No.

SM 332 HART analog output module	6ES7 332-5TB00-0AB0
HART analog output, 8 outputs, 0/4 – 20 mA, HART for ET 200M with IM 153-2	
Accessories	
Front connectors	
20-pin, with screw contacts	
• 1 unit	6ES7 392-1AJ00-0AA0
• 100 units	6ES7 392-1AJ00-1AB0
LK 393 cable guide	6ES7 393-4AA00-0AA0
Mandatory for operation in hazardous areas	
SIMATIC DP mounting rail for ET 200M	
For mounting of up to 5 bus modules for	
• Length: 483 mm (19")	6ES7 195-1GA00-0XA0
• Length: 530 mm	6ES7 195-1GF30-0XA0
SIMATIC S7-300 mounting rail	
• Length: 160 mm	6ES7 390-1AB60-0AA0
• Length: 480 mm (19")	6ES7 390-1AE80-0AA0
• Length: 530 mm	6ES7 390-1AF30-0AA0
• Length: 830 mm	6ES7 390-1AJ30-0AA0
• Length: 2000 mm	6ES7 390-1BC00-0AA0
Label cover	6ES7 392-2XY00-0AA0
(10 units, spare part) for signal modules (not 32-channel modules), function modules and CPU 312 IFM	
Labeling strips	6ES7 392-2XX00-0AA0
(10 units, spare part) for signal modules (not 32-channel modules), function modules and CPU 312 IFM	
Labeling sheets for machine printing	
for modules with 20-pin front connector, DIN A4, for printing with laser printer; 10 units	
petrol	6ES7 392-2AX00-0AA0
light beige	6ES7 392-2BX00-0AA0
yellow	6ES7 392-2CX00-0AA0
red	6ES7 392-2DX00-0AA0
S7 Manual Collection	6ES7 998-8XC01-8YE0
Electronic manuals on DVD, multi-language: S7-200, TD 200, S7-300, M7-300, C7, S7-400, M7-400, STEP 7, Engineering Tools, Runtime Software, SIMATIC DP (Distributed I/O), SIMATIC HMI (Human Machine Interface), SIMATIC NET (Industrial Communication)	
S7 Manual Collection update service for 1 year	6ES7 998-8XC01-8YE2
Scope of delivery: Current DVD "S7 Manual Collection" and the three subsequent updates	

SIMATIC ET 200 distributed I/O

ET 200M

I/O modules

SIPLUS analog input module with HART

Overview



- Can only be plugged into ET 200M with IM 153-2 and IM 153-2 FO
- 8 AI HART
- Redundant connection
- Firmware update
- HART secondary variables

Note:

SIPLUS extreme products are based on Siemens Industry standard products. The contents listed here were taken from the respective standard products. SIPLUS extreme specific information was added.

SIPLUS analog input module with HART

Order No.	6AG1 331-7TF01-7AB0	6AG1 331-7TF01-4AB0
Order No. based on	6ES7 331-7TF01-0AB0	6ES7 331-7TF01-0AB0
Ambient temperature range	-25 °C ... +70 °C	0 °C ... +60 °C
Conformal coating	Coating of the printed circuit boards and the electronic components	
Technical data	The technical data of the standard product applies except for the ambient conditions.	
Ambient conditions		
Relative humidity	100%, condensation/frost permissible. No commissioning if condensation present.	
Biologically active substances, compliance with EN 60721-3-3	Class 3B2 mold and fungal spores (excluding fauna). The supplied plug covers must remain in place over the unused interfaces during operation!	
Chemically active substances, compliance with EN 60721-3-3	Class 3C4 incl. salt spray in accordance with EN60068-2-52 (degree of severity 3). The supplied plug covers must remain in place over the unused interfaces during operation!	
Mechanically active substances, compliance with EN 60721-3-3	Class 3S4 incl. sand, dust. The supplied plug covers must remain in place over the unused interfaces during operation!	
Air pressure (depending on the highest positive temperature range specified)	1 080...795 hPa (-1 000 ... +2 000 m) See ambient temperature range 795...658 hPa (+2 000 ... +3 500 m) Derating 10 K 658...540 hPa (+3 500 ... +5 000m) Derating 20 K	

For technical documentation on SIPLUS, see:
<http://www.siemens.com/siplus-extreme>

Ordering data

SM 331
HART analog input module
 (extended temperature range and medial exposure)
 8 inputs, 0/4 – 20 mA, HART for ET 200M with IM 153-2 interface module
 8 inputs, 0/4 – 20 mA, HART for ET 200M with IM 153-2 interface module; medial exposure only

Order No.

6AG1 331-7TF01-7AB0

6AG1 331-7TF01-4AB0

Accessories

See SIMATIC ET 200M SM 331 analog module with HART, page 9/202

SIMATIC ET 200 distributed I/O

ET 200M

I/O modules

SIPLUS analog output module with HART

Overview



- Pluggable exclusively in ET 200M with IM 153-2 and IM 153-2 FO
- 8 AO HART
- Redundant connection
- Firmware update
- HART secondary variables

Note:

SIPLUS extreme products are based on Siemens Industry standard products. The contents listed here were taken from the respective standard products. SIPLUS extreme specific information was added.

SIPLUS S7-300 SM332 8AO HART

Order No.	6AG1 332-8TF01-2AB0	6AG1 332-8TF01-4AB0
Order No. based on	6ES7 332-8TF01-0AB0	6ES7 332-8TF01-0AB0
Ambient temperature range	-25 °C ... +60 °C	0 °C ... +60 °C
Conformal coating	Coating of the printed circuit boards and the electronic components	
Technical data	The technical data of the standard product applies except for the ambient conditions.	
Ambient conditions		
Relative humidity	100%, condensation/frost permissible. No commissioning if condensation present.	
Biologically active substances, compliance with EN 60721-3-3	Class 3B2 mold and fungal spores (excluding fauna). The supplied plug covers must remain in place over the unused interfaces during operation!	
Chemically active substances, compliance with EN 60721-3-3	Class 3C4 incl. salt spray in accordance with EN60068-2-52 (degree of severity 3). The supplied plug covers must remain in place over the unused interfaces during operation!	
Mechanically active substances, compliance with EN 60721-3-3	Class 3S4 incl. sand, dust. The supplied plug covers must remain in place over the unused interfaces during operation!	
Air pressure (depending on the highest positive temperature range specified)	1,080...795 hPa (-1,000 ... +2,000 m) See ambient temperature range 795...658 hPa (+2,000 ... +3,500 m) Derating 10 K 658...540 hPa (+3 500 ... +5 000m) Derating 20K	

For technical documentation on SIPLUS, see:
<http://www.siemens.com/siplus-extreme>

Ordering data

Order No.

SIPLUS SM 332 analog output module with HART

(medial exposure)

HART analog output, 8 outputs, 0/4 - 20 mA, HART for ET 200M, with IM 153-2

Additionally with expanded temperature range

Accessories

6AG1 332-8TF01-4AB0

6AG1 332-8TF01-2AB0

See SIMATIC SM 332 analog output module with HART, page 9/204

SIMATIC ET 200 distributed I/O

ET 200M

I/O modules

SIPLUS Ex analog input module with HART

Overview



- For connecting HART devices in hazardous areas.
- Can only be plugged into ET 200M
- 2 AI HART, Ex
- 2 inputs in 2 channel groups (single-channel isolation)
- Measurement type/range can be selected for each channel
- Programmable diagnostics and diagnostic interrupt

Note:

SIPLUS extreme products are based on Siemens Industry standard products. The contents listed here were taken from the respective standard products. SIPLUS extreme specific information was added.

SIPLUS Ex analog input module with HART

Order No.	6AG1 331-7TB00-7AB0	6AG1 331-7TB00-4AB0
Order number based on	6ES7 331-7TB00-0AB0	6ES7 331-7TB00-0AB0
Ambient temperature range	-25 °C ... +70 °C 0 °C ... +60 °C	
Conformal coating	Coating of the printed circuit boards and the electronic components	
Technical data	The technical data of the standard product applies except for the ambient conditions.	
Ambient conditions		
Relative humidity	100%, condensation/frost permissible. No commissioning if condensation present.	
Biologically active substances, compliance with EN 60721-3-3	Class 3B2 mold and fungal spores (excluding fauna). The supplied plug covers must remain in place over the unused interfaces during operation!	
Chemically active substances, compliance with EN 60721-3-3	Class 3C4 incl. salt spray in accordance with EN60068-2-52 (degree of severity 3). The supplied plug covers must remain in place over the unused interfaces during operation!	
Mechanically active substances, compliance with EN 60721-3-3	Class 3S4 incl. sand, dust. The supplied plug covers must remain in place over the unused interfaces during operation!	
Air pressure (depending on the highest positive temperature range specified)	1 080...795 hPa (-1 000 ... +2 000 m) See ambient temperature range 795...658 hPa (+2 000 ... +3 500 m) derating 10 K 658...540 hPa (+3 500 ... +5 000m) derating 20K	

For technical documentation on SIPLUS, see:
<http://www.siemens.com/siplus-extreme>

Ordering data

Order No.

SM 331 HART analog input module

(extended temperature range and medial exposure)

2 inputs, 0/4 to 20 mA, HART for ET 200M with IM 153-2 interface module

6AG1 331-7TB00-7AB0

2 inputs, 0/4 to 20 mA, HART for ET 200M with IM 153-2 interface module; medial exposure only

6AG1 331-7TB00-4AB0

Accessories

See SIMATIC ET 200M Ex-analog input module with HART, page 9/206

SIMATIC ET 200 distributed I/O

ET 200M

Function modules

Overview



Function modules unburden the CPU of work-intensive tasks such as counting, positioning and controlling

Module spectrum

- Counter modules
- Positioning modules for rapid traverse and creep speed drives
- Positioning modules for stepper motors
- Positioning modules for servo motors
- Positioning and continuous path modules
- SSI position detection modules
- Electronic cam controllers
- High-speed Boolean processor
- Control modules

Function modules	
Counting	FM 350-1 counter module
	FM 350-2 counter module
Positioning	• of rapid traverse and creep speed drives
	• of stepper motors
	• of servo motors
	FM 351 positioning module
	FM 353 positioning module
	FM 354 positioning module
Position and path control	FM 357-2 path and position control module ¹⁾
SSI position detection	SM 338 POS input modules
Electronic cam control	FM352 electronic cam controller
High speed logic operation	FM 352-5 high speed Boolean processor
Controlling	FM 355 controller module
	FM 355-2 temperature controller module
Weighing and proportioning electronics	SIWAREX

¹⁾ Not for ET 200M

Overview (continued)**Applicability with ET 200M distributed I/O device**

Almost all function modules can be used in the ET 200M distributed I/O device. In doing so, the following details must be observed:

Module	Order No.	For plugging in behind IM 153-1 (6ES7 153-1AA03-0XB0)		For plugging in behind IM 153-2 (6ES7 153-2BA02-0XB0)		For plugging in behind IM 153-2 FO (6ES7 153-2BB00-0XB0)		For plugging in behind IM 153-4 PN (6ES7 153-4AA00-0XB0)
		configurable with STEP 7 ¹⁾	GSD ²⁾	STEP 7 ¹⁾	GSD ²⁾	STEP 7 ¹⁾	GSD ²⁾	STEP 7 ¹⁾
FM 350-1 counter module	6ES7 350-1AH03-0AE0	<input type="checkbox"/>	--	<input type="checkbox"/>	--	<input type="checkbox"/>	--	<input type="checkbox"/>
FM 350-2 counter module	6ES7 350-2AH01-0AE0	<input type="checkbox"/>	--	<input type="checkbox"/>	--	<input type="checkbox"/>	--	<input type="checkbox"/>
FM 351 positioning module	6ES7 351-1AH01-0AE0	<input type="checkbox"/>	--	<input type="checkbox"/>	--	<input type="checkbox"/>	--	<input type="checkbox"/>
FM 352 cam controller	6ES7 352-1AH02-0AE0	<input type="checkbox"/>	--	<input type="checkbox"/>	--	<input type="checkbox"/>	--	<input type="checkbox"/>
FM 352-5 high speed Boolean processor	6ES7 352-5AH00-0AE0	<input checked="" type="checkbox"/> ³⁾	<input type="checkbox"/>	<input checked="" type="checkbox"/> ³⁾	<input type="checkbox"/>	<input checked="" type="checkbox"/> ³⁾	<input type="checkbox"/>	<input type="checkbox"/>
FM 352-5 high speed Boolean processor	6ES7 352-5AH10-0AE0	<input checked="" type="checkbox"/> ³⁾	<input type="checkbox"/>	<input checked="" type="checkbox"/> ³⁾	<input type="checkbox"/>	<input checked="" type="checkbox"/> ³⁾	<input type="checkbox"/>	<input type="checkbox"/>
FM 353 positioning module	6ES7 353-1AH01-0AE0	--	--	<input type="checkbox"/>	--	<input type="checkbox"/>	--	--
FM 354 positioning module	6ES7 354-1AH01-0AE0	--	--	<input type="checkbox"/>	--	<input type="checkbox"/>	--	--
FM 355 C controller module	6ES7 355-0VH10-0AE0	--	--	<input type="checkbox"/>	--	<input type="checkbox"/>	--	<input type="checkbox"/>
FM 355 S controller module	6ES7 355-1VH10-0AE0	--	--	<input type="checkbox"/>	--	<input type="checkbox"/>	--	<input type="checkbox"/>
FM 355-2 C temperature controller module	6ES7 355-2CH00-0AE0	<input type="checkbox"/>	--	<input type="checkbox"/>	--	<input type="checkbox"/>	--	<input type="checkbox"/>
FM 355-2 S temperature controller module	6ES7 355-2SH00-0AE0	<input type="checkbox"/>	--	<input type="checkbox"/>	--	<input type="checkbox"/>	--	<input type="checkbox"/>
SM 338 POS input module	6ES7 338-4BC01-0AB0	<input type="checkbox"/>	<input type="checkbox"/>	<input type="checkbox"/>	<input type="checkbox"/>	<input type="checkbox"/>	<input type="checkbox"/>	<input type="checkbox"/>

configurable
-- not configurable

¹⁾ Configuration using the meta-knowledge integrated into STEP 7 (in hardware catalog under PROFIBUS DP > ET200M > IM 153-1 / IM 153-2 or PROFINET IO > I/O > ET 200M > IM153-4 PN).

²⁾ Configuration using GSD file (after installation of the GSD file configurable from the Hardware Catalog under PROFIBUS DP > Additional field devices > I/O > ET200M). During configuration on the CP 342-5 as DP master, S5 (IM 308C) as DP master or external masters, the GSD file must be configured.

³⁾ Visible and configurable only with the corresponding configuration package in STEP 7.

Note:

Position measurement systems and prefabricated connecting cables for counter and positioning function are offered under SIMODRIVE Sensor and Motion Connect 500.

<http://www.siemens.com/simatic-technology>

For further information, see SIMATIC S7-300, chapter 5.

SIMATIC ET 200 distributed I/O

ET 200M

Special modules, Communication

Overview Special modules



The special modules provide the user with functions for diagnostics, as well as commissioning.

For further information, see SIMATIC S7-300, chapter 5.

Overview Communication



- Communication boards for data exchange using point-to-point coupling
- Communication board for the connection of identification systems

For further information, see SIMATIC S7-300, chapter 5.

Overview



The ASM 475 is a low-cost module for connecting the MOBY D, U, SIMATIC RF200, RF300, RF600 and SIMATIC MV400 identification systems to the S7-300 and ET 200M.

Technical specifications

Order No.	6GT2 002-0GA10
Product-type designation	ASM 475 communication module
Suitability for installation	
Transmission rate at point-to-point connection serial maximum	115.2 kbit/s
Interfaces	
Design of interface for point-to-point connection	RS422
Number of readers connectable	2
Design of electrical connection	S7-300 backplane bus
<ul style="list-style-type: none"> of the backplane bus of the PROFIBUS interface the Industrial Ethernet Interface for supply voltage 	(according to the head module) (according to the head module) Screw-type or spring-loaded terminals
Version of the interface to the reader for communication	Screw-type or spring-loaded terminals
Mechanical data	
Material	Noryl
Color	Anthracite
Supply voltage, current consumption, power loss	
Supply voltage for DC	
<ul style="list-style-type: none"> rated value minimum maximum 	24 V 20 V 30 V
Current consumed at 24 V DC	
<ul style="list-style-type: none"> without connected devices typical including connected devices maximum 	0.1 A 1 A
Permitted ambient conditions	
Ambient temperature	
<ul style="list-style-type: none"> during operating during storage during transport 	0 ... 60 °C -40 ... +70 °C -40 ... +70 °C
Protection class IP	
Resistance against shock	According to IEC 61131-2
Resistance against shock	150 m/s ²
Resistance against vibration	10 m/s ²

Order No.	6GT2 002-0GA10
Product-type designation	ASM 475 communication module
Design, dimensions and weight	
Width	40 mm
Height	125 mm
Depth	120 mm
Net weight	0.2 kg
Type of mounting	S7-300 rack
Cable length for RS 422 interface maximum	1000 m
Product properties, functions, components general	
Type of display	4 LEDs per reader connection, 2 LEDs for device status
Product function transponder file handler can be addressed	Yes
Protocol will be supported S7 communication	Yes
Product functions management, configuration	
Type of parameterization	Object manager, GSD
Type of programming	FB 45, FB 55, FC 56 (FC 45/55 with limited functionality)
Type of computer-mediated communication	acyclic communication
Standards, specifications, approvals	
Verification of suitability	CE, FCC, UL/CSA
Accessories	
Accessories	Front connector with screw-type or spring-loaded terminals

SIMATIC ET 200 distributed I/O

ET 200M

ASM 475

Ordering data	Order No.		Order No.
ASM 475 communication module For SIMATIC S7-300 and ET 200M, parameterizable	6GT2 002-0GA10		
<i>Accessories</i>			
Front connector (1 x per ASM 475) <ul style="list-style-type: none"> with screw terminals with spring-loaded terminals 	6ES7 392-1AJ00-0AA0 6ES7 392-1BJ00-0AA0		
MOBY U connecting cable pre-assembled, between the ASM 475 and reader, angled connector, PUR material, in the following lengths:		SIMATIC RF200 / RF300 / RF600 / MV400 connecting cable pre-assembled, between the ASM 475 and RF200 / RF300 / RF600 / MV400, IP65, straight connector, PUR material, suitable for cable carriers, CMG approval, in the following lengths ¹⁾ :	
2 m	6GT2 091-4EH20	2 m	6GT2 891-4EH20
5 m	6GT2 091-4EH50	5 m	6GT2 891-4EH50
10 m	6GT2 091-4EN10		
20 m	6GT2 091-4EN20	Extension cable SIMATIC RF200 / RF300 / RF600 / MV400, PUR material, CMG approval, suitable for cable carriers, straight connector	
50 m	6GT2 091-4EN50	2 m	6GT2 891-4FH20
		5 m	6GT2 891-4FH50
MOBY D connecting cable pre-assembled, between ASM 475 and reader D1xS, 9-pole Sub-D plug, PUR material, CMG approved, suitable for cable carriers, in the following lengths:		10 m	6GT2 891-4FN10
5 m	6GT2 491-4EH50	20 m	6GT2 891-4FN20
20 m	6GT2 491-4EN20	50 m	6GT2 891-4FN50
50 m	6GT2 491-4EN50	DVD "RFID Systems Software & Documentation"	6GT2 080-2AA20

¹⁾ The connecting cables can be extended using RF300 connecting cables of type 6GT2891-4Fxxx. These connecting cables are available in the lengths 2 m, 5 m, 10 m, 20 m and 50 m.

Overview



- Load current supplies for S7-300/ET 200M
- To convert the line voltage to the required operating voltage (24V DC)
- Output current 2 A, 5 A or 10 A

For further information, see SIMATIC S7-300, chapter 5.

SIMATIC ET 200 distributed I/O

ET 200iSP

Introduction

Overview

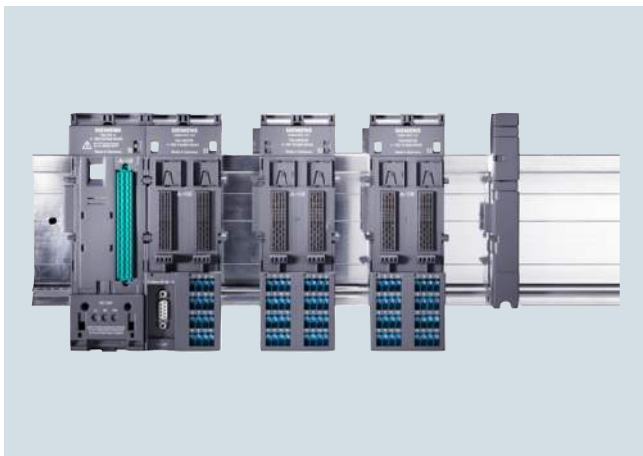

- Failsafe distributed I/O system to IP30 degree of protection for use in hazardous gaseous and dusty areas, i.e. in Zones 1 and 2 as well as 21 and 22
- Sensors and actuators can also be situated directly in Zone 0 or 20.
- Individual configuration and flexible expansion with the modular design for optimization to the respective automation task
- Independent wiring enables prewiring without the electronics connected
- Optimized for integration into process control systems (e.g. SIMATIC PCS 7)
- Parameters can be assigned using SIMATIC PDM
- Optimal integration of HART field devices (HART transparency)
- Failsafe digital inputs and outputs as well as analog inputs for the safety-related signal processing according to PROFIsafe
- Connection to PROFIBUS DP via isolating transformers
- Module replacement (hot swapping) and configuration expansion (Configuration in Run) possible during operation
- Extensive diagnostics possibilities
- Condensation-proof modules in temperature range -20°C to +70°C
- EMC in accordance with NE 21 (on Namur recommendation)
- Full redundancy of PROFIBUS and power supply

Technical specifications

General	
Degree of protection	IP30
Ambient temperature	-20°C ... +70°C
Medial load	In accordance with ISA-S71.04 severity level G1 ;G2 ;G3 (with the exception of NH3 here only Level G2)
EMC	Electromagnetic compatibility in accordance with NE21
Vibration-proof	0.5 g continuously, 1 g periodically
Approvals, standards	
<ul style="list-style-type: none"> • ATEX • IECEx • INMETRO • cFMus 	II 2 G (1) GD I M2 Zone 1 Zone 1 Class I,II,II
<ul style="list-style-type: none"> • cULus 	Class I Class I,II,II
<ul style="list-style-type: none"> • PROFIBUS • IEC • CE • Shipbuilding approval 	Class I EN 50170, Volume 2 IEC 61131, Part 2 In accordance with 94/9/EG (ATEX 100a), 89/336/EEC and 73/23/EEC Classification companies <ul style="list-style-type: none"> • ABS (American Bureau of Shipping) • BV (Bureau Veritas) • DNV (Det Norske Veritas) • GL (Germanischer Lloyd) • LRS (Lloyds Register of Shipping) • Class NK (Nippon Kaiji Kyokai)
	Ex de [ia/ib] IIC T4 Ex de [ia/ib] I Ex de [ia/ib] IIC T4 BR-Ex de [ia/ib] IIC T4 NI Division 2, Groups A, B, C, D, E, F, G T4 AIS Division 1, Groups A, B, C, D, E, F, G Zone 1, AEx de [ia/ib] IIC T4 Division 2, Groups A, B, C, D, E, F, G T4 providing int. safe circuits for Division 1, Groups A, B, C, D, E, F, G Zone 1, AEx de [ia/ib] IIC T4

SIMATIC ET 200 distributed I/O

ET 200iSP

IM 152-1 interface module

Overview



- The IM 152 interface module is plugged onto the corresponding terminal module TM-IM/EM (to be ordered separately). For redundant operation, two IM 152 are used. They are plugged onto the TM-IM/IM.
- The interface module IM 152 has the following properties:
 - Connects the ET 200iSP to PROFIBUS DP
 - Prepares data for the fitted electronic modules
 - The PROFIBUS address of ET 200iSP can be adjusted by switch
 - Slot for MMC
 - Firmware updating over PROFIBUS DP or MMC
- Shutting down the 24 V DC supply voltage at the terminal module TM-PS also shuts down the interface module IM 152.
- The maximum address size is 244 byte inputs and 244 byte outputs.

Technical specifications

6ES7 152-1AA00-0AB0	
General information	
Vendor identification (VendorID)	8110H
Supply voltage	
Mains buffering	
• Mains buffering, min.	f
Input current	
from supply voltage 1L+, max.	30 mA
Power losses	
Power loss, typ.	0.5 W
Time stamping	
Description	for each digital input, digital input module, total ET 200iS
Accuracy	20 ms
Number of stampable digital inputs, max.	64; for accuracy class 20 ms max.
Time format	RFC 1119 Internet (ISP)
Time resolution	1 ms
Time interval for transmitting the message buffer if a message is present	1 000 ms
Time stamp on signal change	rising / falling edge as signal entering or exiting
Interfaces	
Interface physics, RS 485	Yes; (intrinsically safe)
PROFIBUS DP	
• Transmission rate, max.	1.5 Mbit/s; 9.6 / 19.2 / 45.45 / 93.75 / 187.5 / 500 Kbit/s
• SYNC capability	Yes
• FREECE capability	Yes
• Direct data exchange (slave-to-slave communication)	Yes; Slave to slave as publisher
Protocols	
PROFIBUS DP	Yes
Isochronous mode	
Isochronous operation (application synchronized up to terminal)	No

6ES7 152-1AA00-0AB0	
Interrupts/diagnostics/status information	
Alarms	
• Alarms	Yes
• Acyclic function, interrupts	Yes
• Acyclic function, parameters	Yes
Diagnostic messages	
• Diagnostic functions	Yes
Diagnostics indication LED	
• Bus fault BF (red)	Yes
• Group error SF (red)	Yes
• Monitoring 24 V voltage supply ON (green)	Yes
Galvanic isolation	
between supply voltage and electronics	Yes
Standards, approvals, certificates	
CE mark	Yes
Use in hazardous areas	
• Type of protection acc. to EN 50020 (CENELEC)	II2 G Ex ib IIC T4 and I M2 Ex ib I
• Type of protection acc. to KEMA	04 ATEX 1243
Dimensions	
Width	30 mm
Height	129 mm
Depth	136.5 mm
Weight	
Weight, approx.	245 g

Technical specifications (continued)

	6ES7 193-7AA00-0AA0	6ES7 193-7AA10-0AA0	6ES7 193-7AB00-0AA0
Standards, approvals, certificates			
CE mark	No	No	No
Use in hazardous areas			
• Type of protection acc. to EN 50020 (CENELEC)	No	No	No
• Test number KEMA	04 ATEX 2242	04 ATEX 2242	04 ATEX 2242
Dimensions			
Width	60 mm	60 mm	60 mm
Height	190 mm	190 mm	190 mm
Depth	52 mm	52 mm	52 mm
Weight			
Weight, approx.	235 g	235 g	195 g

Ordering data

	Order No.		Order No.
IM152		Labeling sheet	
• ET 200iSP-IM152-1	6ES7 152-1AA00-0AB0	DIN A4, perforated, each consisting of 10 sheets of 30 strips each for electronic modules, and 20 strips each for IM 152	
Terminal module for IM152 incl. termination module		• petrol	6ES7 193-7BH00-0AA0
• TM-IM/EM60S (blue screw-type terminals)	6ES7 193-7AA00-0AA0	• red	6ES7 193-7BD00-0AA0
• TM-IM/EM60C (blue spring-loaded terminals)	6ES7 193-7AA10-0AA0	• yellow	6ES7 193-7BB00-0AA0
• TM-IM/IM (black screw-type terminals)	6ES7 193-7AB00-0AA0	• light beige	6ES7 193-7BA00-0AA0
Accessories		Labels, inscribed	
ET 200iSP manual		Ordering unit 1 set with 200 pieces each for slot numbering	
• German	6ES7 152-1AA00-8AA0	• 10 x slots 1 to 2	8WA8 861-0AB
• English	6ES7 152-1AA00-8BA0	• 5 x slots 1 to 40	8WA8 861-0AC
Connectors		• 1 x slot 1 to 64 2 x slots 1 to 68	8WA8 861-0DA
PROFIBUS connector with active terminating resistor	6ES7 972-0DA60-0XA0	Labels, blank	
For RS 485-IS circuit; 1.5 Mbit/s		Ordering unit 1 set with 200 pieces each for slot numbering	8WA8 848-2AY
RS 485-IS coupler		S7-300 mounting rails	
Isolating transformer for coupling of PROFIBUS DP and PROFIBUS RS 485-IS	6ES7 972-0AC80-0XA0	Standard rail 585 mm	6ES7 390-1AF85-0AA0
		Standard rail 885 mm	6ES7 390-1AJ85-0AA0
		Stainless steel enclosure	
			see page 9/250

SIMATIC ET 200 distributed I/O

ET 200iSP

Power supply units

Overview



The power supply (PS) is plugged into the associated terminal module TM-PS-A or TM-PS-B (with redundancy; to be ordered separately).

The power supply unit fulfills the following functions:

- It provides reliable isolated power supply for the ET 200iSP with the necessary operating voltages for
 - logic (through the backplane bus)
 - PROFIBUS DP interface of IM 152-1
 - powerbus (for supplying the electronic modules)
- Takes over the safety limit of the output voltage
- Has an explosion-proof metal enclosure (explosion protection EEx d)
- Can be redundantly configured

Technical specifications

	6ES7 138-7EA01-0AA0	6ES7 138-7EC00-0AA0
Supply voltage		
Load voltage L+		
• Rated value (DC)	24 V	
• Reverse polarity protection	Yes	
Load voltage L1		
• Rated value (AC)		230 V; 120/230 V AC
• permissible range, lower limit (AC)		85 V
• permissible range, upper limit (AC)		264 V
• permissible frequency range, lower limit		47 Hz
• permissible frequency range, upper limit		63 Hz
Input current		
from supply voltage L+, max.	4 A	
from supply voltage L1, max.		1.04 A; at rated voltage 230 VAC:0.45A at rated voltage 120 VAC:0.75A
Power losses		
Power loss, typ.	20 W	5 W; 5 W + 1.2 x total power loss of the electronics modules
Power loss, max.		21.3 W
Interrupts/diagnostics/status information		
Status indicator	Yes	Yes
Alarms		
• Alarms	No	No
Diagnostic messages		
• Diagnostic information readable	Yes; via IM 152	Yes; via IM 152
Diagnostics indication LED		
• Group error SF (red)	No	No
Ex(i) characteristics		
Max. values of input circuits (per channel)		
• Um (fault voltage), max.	250 V; DC	264 V; AC/DC
Galvanic isolation		
primary/secondary	Yes	Yes
between supply voltage and electronics	Yes	No

Technical specifications (continued)

	6ES7 138-7EA01-0AA0	6ES7 138-7EC00-0AA0
Standards, approvals, certificates		
CE mark	Yes	Yes
Use in hazardous areas		
• Type of protection acc. to EN 50020 (CENELEC)	Ex de [ib] IIC T4	Ex de [ib] IIC T4
• Type of protection acc. to KEMA	04 ATEX 2263	09 ATEX 0156
Dimensions		
Width	60 mm	60 mm
Height	190 mm	190 mm
Depth	136.5 mm	136.5 mm
Weight		
Weight, approx.	2 700 g	2 700 g

	6ES7 193-7DA10-0AA0	6ES7 193-7DB10-0AA0	6ES7 193-7DA20-0AA0	6ES7 193-7DB20-0AA0
Standards, approvals, certificates				
CE mark			Yes	Yes
Use in hazardous areas				
• Type of protection acc. to EN 50020 (CENELEC)			II 2 G (1) GD and I M2 Ex e [ia/ib] IIC T4; Ex e [ia/ib] I	II 2 G (1) GD and I M2 Ex e [ia/ib] IIC T4; Ex e [ia/ib] I
• Test number KEMA			04 ATEX 2242	04 ATEX 2242
Dimensions				
Width	60 mm	60 mm	60 mm	60 mm
Height	190 mm	190 mm	190 mm	190 mm
Depth	52 mm	52 mm	52 mm	52 mm
Weight				
Weight, approx.			230 g	230 g

Ordering data

Ordering data	Order No.	Ordering data	Order No.
PS 24 V DC power supply module	6ES7 138-7EA01-0AA0	PS 120/230 V AC power supply module	6ES7 138-7EC00-0AA0
TM-PS-A Standard terminal module	6ES7 193-7DA10-0AA0	TM-PS-A UC Standard terminal module	6ES7 193-7DA20-0AA0
TM-PS-B terminal module for redundant operation	6ES7 193-7DB10-0AA0	TM-PS-B UC terminal module for redundant operation	6ES7 193-7DB20-0AA0

SIMATIC ET 200 distributed I/O

ET 200iSP

Digital electronic modules

Overview



- The electronic modules are plugged into the associated terminal modules that must be ordered separately (with screw-type or spring-loaded terminals).
- When plugged in, the modules are automatically uniquely coded mechanically.
- Modules can be replaced under potentially explosive conditions during runtime.

Technical specifications

6ES7 131-7RF00-0AB0	
Digital inputs	
Number/binary inputs	8
Number of NAMUR inputs	8
Input voltage	
• Type of input voltage	DC
Input delay (for rated value of input voltage)	
• for standard inputs	
- at "0" to "1", min.	2.8 µs
- at "0" to "1", max.	3.5 µs
- at "1" to "0", min.	2.8 ms
- at "1" to "0", max.	3.5 µs
Cable length	
• Cable length, shielded, max.	500 m
Encoder	
Number of connectable encoders, max.	8
Connectable encoders	
• NAMUR encoder	Yes
NAMUR encoder	
• Input current, for signal "0", max.	1.2 mA
• Input current, for signal "1", min.	2.1 mA
Interrupts/diagnostics/status information	
Alarms	
• Diagnostic alarm	Yes; Parameterizable
• Hardware interrupt	No
Diagnostic messages	
• Diagnostic functions	Yes
• Diagnostic information readable	Yes
• Short circuit	Yes; R load < 150 ohms with NAMUR sensor/sensor and NAMUR changeover contact/sensor to DIN 19234
Diagnostics indication LED	
• Group error SF (red)	Yes

6ES7 131-7RF00-0AB0	
Integrated Functions	
Frequency meter	Yes
Frequency measurement	Yes; (Gate time) 50 ms; 200 ms; 1 s
Number of frequency meters	2
Counter	
Number of counter inputs	2; normal and periodic count function
Input frequency, max.	5 kHz; with a cable length of 20 m: 5 kHz; with a cable length of 100 m: 1 kHz; with a cable length of 200 m: 500 Hz
Galvanic isolation	
Galvanic isolation digital inputs	
• between the channels	No
• between the channels and the backplane bus	Yes
Permissible potential difference	
between different circuits	60 V DC/30 V AC
Standards, approvals, certificates	
CE mark	Yes
Use in hazardous areas	
• Type of protection acc. to EN 50020 (CENELEC)	I I2 G (1) GD Ex ib[ia] IIC T4 and I M2 Ex ib[ia] I
• Type of protection acc. to KEMA	04 ATEX 1248
Dimensions	
Width	30 mm
Height	129 mm
Depth	136.5 mm
Weight	
Weight, approx.	255 g

Technical specifications (continued)

	6ES7 132-7RD01-0AB0	6ES7 132-7RD11-0AB0	6ES7 132-7RD22-0AB0
Input current			
from load voltage L+ (without load), max.	340 mA; with actuator supply	300 mA	2.8 mA
from backplane bus 3.3 V DC, max.	10 mA	10 mA	
Power losses			
Power loss, typ.	2.5 W	2.1 W	2.8 W
Address area			
Address space per module			
• without packing	2 byte	2 byte	2 byte
Digital inputs			
Cable length			
• Cable length, shielded, max.			20 m
• Cable length unshielded, max.			20 m
Digital outputs			
Number/binary outputs	4; additionally 1 intrinsically-safe input for H shutdown	4; additionally 1 intrinsically-safe input for H shutdown	4; additionally 1 intrinsically-safe input for H shutdown
Functionality/short-circuit strength	Yes; Ex i function	Yes	Yes
No-load voltage U_{ao} (DC)	23.1 V	17.4 V	17.4 V
Internal resistor R_i	275 Ω	150 Ω	167 Ω
Trend key points E			
• Voltage U_e (DC)	17.1 V	13.2 V	10.7 V
• Current I_e	20 mA	27 mA	40 mA; 80 mA when outputs connected in parallel
Output current			
• for signal "1" rated value	0.02 A	0.03 A	
Output delay with resistive load			
• "0" to "1", max.	2 ms	2 ms	2 ms
• "1" to "0", max.	1.5 ms	1.5 ms	1.5 ms
Parallel switching of 2 outputs			
• for increased power	No; for Ex reasons not possible; nor for predecessor	Yes	Yes
Switching frequency			
• with resistive load, max.	100 Hz	100 Hz	100 Hz
• with inductive load, max.	2 Hz	2 Hz	2 Hz
Cable length			
• Cable length, shielded, max.	500 m	500 m	500 m
• Cable length unshielded, max.	500 m	500 m	500 m
Interrupts/diagnostics/status information			
Status indicator			Yes
Substitute values connectable			Yes
Alarms			
• Alarms		No	No
• Diagnostic alarm	Yes	Yes	Yes; Parameterizable
Diagnostic messages			
• Diagnostic functions	Yes	Yes	Yes
• Diagnostic information readable	Yes	Yes	Yes
• Wire break	Yes; $R > 10$ kohms, $I < 100$ μ A	Yes	Yes; $R > 10$ kohms, $I < 100$ μ A
• Short circuit	Yes; $R < 800$ ohms (one output), $R < 40$ ohms (outputs connected in parallel)	Yes	Yes; $R < 80$ Ohm (one output), $R < 40$ Ohm (outputs connected in parallel)
Diagnostics indication LED			
• Group error SF (red)	Yes	Yes	Yes
• Status indicator digital output (green)	Yes	Yes	Yes; Per channel
Parameter			
Remark		14 bytes	
Diagnosis: wire break	Yes	Yes	Yes
Diagnosis: short circuit	Yes	Yes	Yes
Behavior on CPU/Master STOP, channel-wise	Yes	Yes	Substitute a value/keep last value

SIMATIC ET 200 distributed I/O

ET 200iSP

Digital electronic modules

Technical specifications (continued)

	6ES7 132-7RD01-0AB0	6ES7 132-7RD11-0AB0	6ES7 132-7RD22-0AB0	
Ex(i) characteristics Max. values of output circuits (per channel) • Co (permissible external capacity), max. • Io (short-circuit current), max. • Lo (permissible external inductivity), max. • Po (power of load), max. • Uo (output no-load voltage), max. • Ta (permissible ambient temperature), max.	70 °C	70 °C	241 nF; For IIC, 1507 nF for IIB 118 mA 1.7 mH; For IIC, 10.4 mH for IIB 572 mW 19.4 V	
Galvanic isolation Galvanic isolation digital outputs • between the channels • between the channels and the backplane bus • between the channels and the load voltage L+			No Yes Yes	
Permissible potential difference between different circuits			60V DC/30V AC	
Standards, approvals, certificates CE mark	Yes	Yes	Yes	
Use in hazardous areas • Type of protection acc. to EN 50020 (CENELEC) • Type of protection acc. to KEMA	II2 G (1) GD Ex ib[ia] I IIC T4 and I M2 Ex ib[ia] I Not relevant	II2 G (1) GD Ex ib[ia] I IIC T4 and I M2 Ex ib[ia] I Not relevant	04 ATEX 1249	
Dimensions Width	30 mm	30 mm	30 mm	
Height	129 mm	129 mm	129 mm	
Depth	136.5 mm	136.5 mm	136.5 mm	
Weight Weight, approx.	255 g	255 g	255 g	
	6ES7 132-7GD00-0AB0	6ES7 132-7GD10-0AB0	6ES7 132-7GD21-0AB0	6ES7 132-7GD30-0AB0
Input current from load voltage L+ (without load), max.	340 mA; with actuator supply	300 mA; with actuator supply	400 mA	400 mA
from backplane bus 3.3 V DC, max.	10 mA	10 mA		
Power losses Power loss, typ.	2.5 W	2.1 W	2.8 W	2.8 W
Address area Address space per module • without packing	2 byte	2 byte	2 byte	2 byte
Digital inputs Cable length • Cable length, shielded, max. • Cable length unshielded, max.			20 m 20 m	20 m 20 m
Digital outputs Number/binary outputs	4; additionally 1 intrinsically-safe input for L shut-down	4; additionally 1 intrinsically-safe input for L shut-down	4; additionally 1 intrinsically-safe input for L shut-down	4; additionally 1 intrinsically-safe input for L shut-down
Functionality/short-circuit strength	Yes; Ex i function	Yes; Ex i function	Yes	Yes
No-load voltage Uao (DC)	23.1 V	17.4 V	17.4 V	25.5 V
Internal resistor Ri		150 Ω	167 Ω	260 Ω
Trend key points E • Voltage Ue (DC) • Current Ie	17.1 V 20 mA	13.2 V 27 mA; 54 mA when outputs connected in parallel	10.7 V 40 mA	19.8 V 22 mA

Technical specifications (continued)

	6ES7 132-7GD00-0AB0	6ES7 132-7GD10-0AB0	6ES7 132-7GD21-0AB0	6ES7 132-7GD30-0AB0
Output current • for signal "1" rated value	0.02 A	0.02 A		
Output delay with resistive load • "0" to "1", max. • "1" to "0", max.	2 ms 1.5 ms	2 ms 1.5 ms	2 ms 1.5 ms	2 ms 1.5 ms
Parallel switching of 2 outputs • for increased power	No; for Ex reasons not possible; nor for predecessor	Yes	Yes	No
Switching frequency • with resistive load, max. • with inductive load, max.	100 Hz 2 Hz	100 Hz 2 Hz	100 Hz 2 Hz	100 Hz 2 Hz
Cable length • Cable length, shielded, max. • Cable length unshielded, max.	500 m 500 m	500 m 500 m	500 m 500 m	500 m 500 m
Interrupts/diagnostics/ status information				
Status indicator			Yes	Yes
Substitute values connectable			Yes	Yes
Alarms • Alarms • Diagnostic alarm	Yes	Yes	No Yes; Parameterizable	Yes; Parameterizable
Diagnostic messages • Diagnostic functions • Diagnostic information readable • Wire break • Short circuit	Yes Yes Yes; R > 10 kohms, I < 100 µA Yes; R < 80 Ohm (one out- put), R < 40 Ohm (outputs connected in parallel)	Yes Yes Yes; R > 10 kohms, I < 100 µA Yes; R < 800 ohms (one out- put), R < 40 ohms (outputs connected in parallel)	Yes Yes; R > 10 kohms, I < 100 µA Yes; R < 80 Ohm (one out- put), R < 40 Ohm (outputs connected in parallel)	Yes Yes; R > 10 kohms, I < 100 µA Yes; R < 80 ohms
Diagnostics indication LED • Group error SF (red) • Status indicator digital output (green)	Yes Yes	Yes Yes	Yes Yes; Per channel	Yes Yes; Per channel
Parameter				
Remark	14 bytes	14 bytes		
Diagnosis: wire break	Yes	Yes	Yes	Yes
Diagnosis: short circuit	Yes	Yes	Yes	Yes
Behavior on CPU/Master STOP, channel-wise	Yes	Yes	Substitute a value/keep last value	Substitute a value/keep last value
Ex(i) characteristics				
Max. values of output circuits (per channel) • Co (permissible external capacity), max. • Io (short-circuit current), max. • Lo (permissible external inductivity), max. • Po (power of load), max. • Uo (output no-load voltage), max. • Ta (permissible ambient tempera- ture), max.	70 °C	70 °C	241 nF; For IIC, 1507 nF for IIB 118 mA 1.7 mH; For IIC, 10.4 mH for IIB 572 mW 19.4 V	81 nF; For IIC, 651 nF for IIB 110 mA 1.7 mH; For IIC, 11.5 mH for IIB 764 mW 27.9 V
Galvanic isolation				
Galvanic isolation digital outputs • between the channels • between the channels and the backplane bus • between the channels and the load voltage L+			No Yes Yes	No Yes Yes
Permissible potential difference between different circuits			60V DC/30V AC	60V DC/30V AC

SIMATIC ET 200 distributed I/O

ET 200iSP

Digital electronic modules

Technical specifications (continued)

	6ES7 132-7GD00-0AB0	6ES7 132-7GD10-0AB0	6ES7 132-7GD21-0AB0	6ES7 132-7GD30-0AB0
Standards, approvals, certificates				
CE mark	Yes	Yes	Yes	Yes
Use in hazardous areas				
• Type of protection acc. to EN 50020 (CENELEC)	II 2 G (1) GD Ex ib [ia] IIC T4 and I M2 Ex ib [ia] I	II 2 G (1) GD Ex ib [ia] IIC T4 and I M2 Ex ib [ia] I	II 2 G (1) GD and I M2 Ex ib [ia] [iaD] IIC T4; Ex ib [ia] I	II 2 G (1) GD and I M2 Ex ib [ia] [iaD] IIC T4; Ex ib [ia] I
• Type of protection acc. to KEMA	Not relevant	Not relevant	04 ATEX 1249	04 ATEX 1249
Dimensions				
Width	30 mm	30 mm	30 mm	30 mm
Height	129 mm	129 mm	129 mm	129 mm
Depth	136.5 mm	136.5 mm	136.5 mm	136.5 mm
Weight				
Weight, approx.	255 g	255 g	255 g	255 g

	6ES7 132-7HB00-0AB0
Input current	
from load voltage L+ (without load), max.	120 mA
Power losses	
Power loss, typ.	1 W
Digital outputs	
Number/binary outputs	2
Functionality/short-circuit strength	Yes
Output current	
• for signal "1" rated value	2 A
Output delay with resistive load	
• "0" to "1", max.	8 ms
• "1" to "0", max.	3 ms
Parallel switching of 2 outputs	
• for increased power	No
• for redundant control of a load	No
Switching frequency	
• with resistive load, max.	0.5 Hz; See data in manual
• with inductive load, max.	0.2 Hz; See data in manual
Relay outputs	
• Switching capacity of contacts	
- at ohmic load, up to 60 °C, max.	2 A; See data in manual
- Thermal continuous current, max.	2 A; See data in manual
Cable length	
• Cable length, shielded, max.	500 m
• Cable length unshielded, max.	500 m
Interrupts/diagnostics/status information	
Substitute values connectable	Yes
Alarms	
• Alarms	No
• Diagnostic alarm	Yes
• Hardware interrupt	No
Diagnostic messages	
• Diagnostic information readable	Yes
• Wire break	No; Cannot be determined in contact power circuit
• Short circuit	No; Cannot be determined in contact power circuit
Diagnostics indication LED	
• Group error SF (red)	Yes
• Status indicator digital output (green)	Yes; Per channel

	6ES7 132-7HB00-0AB0
Ex(i) characteristics	
Max. values of output circuits (per channel)	
• U _o (output no-load voltage), max.	60 V
• U _m (fault voltage), max.	250 V
• T _a (permissible ambient temperature), max.	70 °C
Galvanic isolation	
Galvanic isolation digital outputs	
• between the channels	Yes
• between the channels and the backplane bus	Yes
• between the channels and the load voltage L+	Yes; Channels and power bus
Standards, approvals, certificates	
CE mark	Yes
Use in hazardous areas	
• Type of protection acc. to EN 50020 (CENELEC)	II 2 G and I M2 Ex eibmb IIC T4; Ex eibmb I
• Type of protection acc. to KEMA	07 ATEX 0180
Dimensions	
Width	30 mm
Height	129 mm
Depth	136.5 mm
Weight	
Weight, approx.	280 g

Technical specifications (continued)

	6ES7 193-7CA00-0AA0	6ES7 193-7CA10-0AA0	6ES7 193-7CB00-0AA0
Standards, approvals, certificates			
CE mark	No	No	Yes
Use in hazardous areas			
• Type of protection acc. to EN 50020 (CENELEC)	No	No	II 2 G and I M2 Ex deib IIC T4; Ex deib I
• Test number KEMA	04 ATEX 2242	04 ATEX 2242	07 ATEX 0205
Dimensions			
Width	60 mm	60 mm	60 mm
Height	190 mm	190 mm	190 mm
Depth	52 mm	52 mm	52 mm
Weight			
Weight, approx.	275 g	275 g	340 g

Ordering data

	Order No.	Order No.
Digital input modules		
8 x DI NAMUR		
Digital input module 8 DI NAMUR	6ES7 131-7RF00-0AB0	
Digital output modules for EEX i		
4 x DO; 1 additional intrinsically safe input for "H" shut-off		
Digital output module 4 DO 23.1 V DC/20 mA	6ES7 132-7RD01-0AB0	
Digital output module 4 DO 17.4 V DC/27 mA	6ES7 132-7RD11-0AB0	
Digital output module 4 DO 17.4 V DC/40 mA	6ES7 132-7RD22-0AB0	
4 x DO; 1 additional intrinsically safe input for "L" shut-off		
Digital output module 4 DO 23.1 V DC/20 mA	6ES7 132-7GD00-0AB0	
Digital output module 4 DO 17.4 V DC/27 mA	6ES7 132-7GD10-0AB0	
Digital output module 4 DO 17.4 V DC/40 mA	6ES7 132-7GD21-0AB0	
Digital output module 4 DO 25.4 V DC/22 mA	6ES7 132-7GD30-0AB0	
Digital output modules for EEX e		
Digital output module 2 DO relay, 60 V UC, 2 A	6ES7 132-7HB00-0AB0	
Terminal modules		
TM-EM/EM60S	6ES7 193-7CA00-0AA0	
(blue screw-type terminals) for accommodating all electronic modules except 2 DO relay; screw-type terminals		
TM-EM/EM60C	6ES7 193-7CA10-0AA0	
(blue spring-loaded terminals) for accommodating all electronic modules except 2 DO relay; spring-loaded terminals		
TM-EM/EM60S	6ES7 193-7CA20-0AA0	
(black screw-type terminals) for accommodating all electronic modules except 2 DO relay; screw-type terminals		
TM-RM/RM 60S	6ES7 193-7CB00-0AA0	
for accommodating digital output module 2 DO relay and reserve modules; screw-type terminal		
Accessories		
ET 200iSP manual		
• German		6ES7 152-1AA00-8AA0
• English		6ES7 152-1AA00-8BA0
Connectors		
PROFIBUS connector with active terminating resistor		6ES7 972-0DA60-0XA0
For RS 485-IS circuit; 1.5 Mbit/s		
RS 485-IS coupler		6ES7 972-0AC80-0XA0
Isolating transformer for coupling of PROFIBUS DP and PROFIBUS RS 485-IS		
Labeling sheet		
DIN A4, perforated, each consisting of 10 sheets of 30 strips each, used for electronic modules and 20 strips, used for IM 151		
• petrol		6ES7 193-7BH00-0AA0
• red		6ES7 193-7BD00-0AA0
• yellow		6ES7 193-7BB00-0AA0
• light beige		6ES7 193-7BA00-0AA0
Labels, inscribed		
Ordering unit 1 set with 200 pieces each for slot numbering		
• 10 x slots 1 to 2		8WA8 861-0AB
• 5 x slots 1 to 40		8WA8 861-0AC
Labels, blank		8WA8 848-2AY
Ordering unit 1 set with 200 pieces each for slot numbering		
S7-300 mounting rails		
Standard rail 585 mm		6ES7 390-1AF85-0AA0
Standard rail 885 mm		6ES7 390-1AJ85-0AA0
Stainless steel enclosure		see page 9/250

SIMATIC ET 200 distributed I/O

ET 200iSP

Analog electronic modules

Overview



- The electronic modules are plugged into the associated terminal modules that must be ordered separately (with screw-type or spring-loaded terminals)
- When plugged in, the modules are automatically uniquely coded mechanically
- Modules can be replaced under potentially explosive conditions during runtime

Technical specifications

	6ES7 134-7SD00-0AB0	6ES7 134-7SD51-0AB0	6ES7 134-7TD00-0AB0	6ES7 134-7TD50-0AB0
Input current from supply voltage L+, max.	30 mA	22 mA	320 mA	30 mA
Output voltage Power supply to the transmitters • short-circuit proof • Supply current, max.			Yes 23 mA; per channel	
Power losses Power loss, typ.	0.4 W	0.4 W	2.7 W	0.4 W
Analog inputs Number of analog inputs	4	4	4	4
permissible input current for current input (destruction limit), max.			90 mA	50 mA
Cycle time (all channels) max.	320 ms; 66 ms basic conversion time x 4 channels with 60 Hz interference frequency suppression; 80 ms basic conversion time x 4 channels with 50 Hz interference frequency suppression	320 ms; 66 ms basic conversion time x 4 channels with 60 Hz interference frequency suppression; 80 ms basic conversion time x 4 channels with 50 Hz interference frequency suppression	120 ms; 30 ms basic conversion time x 4 channels with 60 Hz, 50 Hz interference frequency suppression	120 ms; 30 ms basic conversion time x 4 channels with 60 Hz, 50 Hz interference frequency suppression
Technical unit for temperature measurement adjustable	Yes	Yes	Yes	Yes
Input ranges • Voltage • Current • Thermocouple • Resistance thermometer • Resistance	Yes No Yes No No	No No No Yes Yes	No Yes No No No	No Yes No No No
Input ranges (rated values), voltages • -80 mV to +80 mV • Input resistance (-80 mV to +80 mV)	Yes 1 000 kΩ			
Input ranges (rated values), currents • 4 to 20 mA			Yes	Yes; Min. 295 Ohm

Technical specifications (continued)

	6ES7 134-7SD00-0AB0	6ES7 134-7SD51-0AB0	6ES7 134-7TD00-0AB0	6ES7 134-7TD50-0AB0
Input ranges (rated values), thermoelements				
• Type B	Yes			
• Input resistance (Type B)	1 000 kΩ			
• Type C	Yes			
• Input resistance (Type C)	1 000 kΩ			
• Type E	Yes			
• Input resistance (Type E)	1 000 kΩ			
• Type J	Yes			
• Input resistance (type J)	1 000 kΩ			
• Type K	Yes			
• Input resistance (Type K)	1 000 kΩ			
• Type L	Yes			
• Input resistance (Type L)	1 000 kΩ			
• Type N	Yes			
• Input resistance (Type N)	1 000 kΩ			
• Type R	Yes			
• Input resistance (Type R)	1 000 kΩ			
• Type S	Yes			
• Input resistance (Type S)	1 000 kΩ			
• Type T	Yes			
• Input resistance (Type T)	1 000 kΩ			
• Type U	Yes			
• Input resistance (Type U)	1 000 kΩ			
Input ranges (rated values), resistance thermometers				
• Ni 100		Yes		
• Input resistance (Ni 100)		2 000 kΩ		
• Pt 100		Yes		
• Input resistance (Pt 100)		2 000 kΩ		
Input ranges (rated values), resistors				
• 0 to 600 ohms		Yes; Also 1000 ohms		
• Input resistance (0 to 600 ohms)		1 000 kΩ		
Thermocouple (TC)				
• for thermocouples	1			
• Temperature compensation				
- internal temperature compensation	Yes; via supplied TC sensor module			
- external temperature compensation with compensations socket	Yes; via temperature value, acquired by an analog module of the same ET 200iSP station			
Resistance thermometer (RTD)				
• Characteristic linearization				
- for resistance thermometer		Yes		
Characteristic linearization				
• Parameterizable	Yes	Yes		
Cable length				
• Cable length, shielded, max.	50 m	500 m	500 m	500 m
Analog value creation				
Measurement principle	integrating (Sigma-Delta)	integrating (Sigma-Delta)	integrating (Sigma-Delta)	integrating (Sigma-Delta)
Integrations and conversion time/ resolution per channel				
• Resolution with overrange (bit including sign), max.	16 bit	16 bit	13 bit	12 bit; + sign
• Integration time, parameterizable	Yes	Yes	No	Yes
• Basic conversion time, including integration time, ms	80 ms at 50 Hz; 66 ms at 60 Hz	80 ms at 50 Hz; 66 ms at 60 Hz		30
- additional conversion time for wire break monitoring	5	5		
• Interference voltage suppression for interference frequency f1 in Hz	50 / 60 Hz	50 / 60 Hz	50 / 60 Hz	50 / 60 Hz

SIMATIC ET 200 distributed I/O

ET 200iSP

Analog electronic modules

Technical specifications (continued)

	6ES7 134-7SD00-0AB0	6ES7 134-7SD51-0AB0	6ES7 134-7TD00-0AB0	6ES7 134-7TD50-0AB0
Smoothing of measured values				
• Parameterizable	Yes; in 4 stages	Yes; in 4 stages	Yes; in 4 stages	Yes; in 4 stages
• Step: None	Yes; 1 x cycle time	Yes; 1 x cycle time	Yes; 1 x cycle time	Yes; 1 x cycle time
• Step: low	Yes; 4 x cycle time	Yes; 4 x cycle time	Yes; 4 x cycle time	Yes; 4 x cycle time
• Step: Medium	Yes; 32 x cycle time	Yes; 32 x cycle time	Yes; 32 x cycle time	Yes; 32 x cycle time
• Step: High	Yes; 64 x cycle time	Yes; 64 x cycle time	Yes; 64 x cycle time	Yes; 64 x cycle time
Encoder				
Connection of signal encoders			Yes	
• for current measurement as 2-wire transducer			750 Ω	
• Burden of 2-wire transmitter, max.				Yes
• for current measurement as 4-wire transducer		Yes		
• for resistance measurement with 2-conductor connection		Yes		
• for resistance measurement with 3-conductor connection		Yes		
• for resistance measurement with 4-conductor connection		Yes		
Errors/accuracies				
Linearity error (relative to input area)	+/- 0.015 %	+/- 0.015 %	+/- 0.015 %	+/- 0.015 %
Temperature error (relative to input area)	+/- 0.02 %	+/- 0.02 %	+/- 0.005 %/K	+/- 0.005 %/K
Crosstalk between the inputs, min.	-50 dB	-50 dB	-50 dB	-50 dB
Repeat accuracy in settled status at 25 °C (relative to input area)	+/- 0.01 %	+/- 0.01 %	+/- 0.01 %	+/- 0.01 %
Operational limit in overall temperature range				
• Voltage, relative to input area	+/- 0.15 %		+/- 0.15 %	+/- 0.15 %
• Current, relative to input area				
• Resistance-type thermometer, relative to input area		+/- 0.15 %; Applies to resistances standard +/- 0.8K climatic +/- 0.3K		
Basic error limit (operational limit at 25 °C)				
• Voltage, relative to input area	+/- 0.1 %		+/- 0.1 %	+/- 0.1 %
• Current, relative to input area				
• Resistance-type thermometer, relative to input area		+/- 0.1 %; Applies to resistances standard +/- 0.5 K climatic +/- 0.2 K		
Interference voltage suppression for $f = n \times (f1 \pm 1\%)$, $f1 =$ interference frequency				
• Series mode interference (peak value of interference < rated value of input range), min.	70 dB	70 dB	70 dB	70 dB
• Common mode interference, min.	90 dB	90 dB		
Interrupts/diagnostics/status information				
Alarms				
• Diagnostic alarm	Yes; Parameterizable	Yes	Yes; Parameterizable	Yes; Parameterizable
• Limit value alarm	Yes; Parameterizable	Yes	Yes; Parameterizable	Yes; Parameterizable
Diagnostic messages				
• Diagnostic information readable	Yes	Yes	Yes	Yes
• Wire break		Yes	Yes	Yes
• Short circuit		Yes	Yes	
• Group error		Yes		
Diagnostics indication LED				
• Group error SF (red)	Yes	Yes	Yes	Yes

Technical specifications (continued)

	6ES7 134-7SD00-0AB0	6ES7 134-7SD51-0AB0	6ES7 134-7TD00-0AB0	6ES7 134-7TD50-0AB0
Galvanic isolation				
Galvanic isolation analog inputs				
• between the channels	Yes; Functional, yes	No	No	No
• between the channels and the backplane bus	Yes	Yes	Yes	Yes
• between the channels and the load voltage L+		Yes; Channels and power bus		
Standards, approvals, certificates				
CE mark	Yes	Yes	Yes	Yes
Use in hazardous areas				
• Type of protection acc. to EN 50020 (CENELEC)	II2 G (1) GD Ex ib[ia] IIC T4 and I M2 Ex ib[ia] I	II2 G (1) GD Ex ib[ia] IIC T4 and I M2 Ex ib[ia] I	II2 G (1) GD Ex ib[ia] IIC T4 and I M2 Ex ib[ia] I	II2 G (1) GD Ex ib[ia] IIC T4 and I M2 Ex ib[ia] I
• Type of protection acc. to KEMA	04 ATEX 1246	04 ATEX 1247	04 ATEX 1244	04 ATEX 1245
Dimensions				
Width	30 mm	30 mm	30 mm	30 mm
Height	129 mm	129 mm	129 mm	129 mm
Depth	136.5 mm	136.5 mm	136.5 mm	136.5 mm
Weight				
Weight, approx.	230 g	230 g	230 g	230 g

	6ES7 135-7TD00-0AB0
Input current	
from load voltage 1L+, max.	330 mA
Power losses	
Power loss, max.	2.7 W
Analog outputs	
Number of analog outputs	4
Cycle time (all channels) max.	3.6 ms
Output ranges, current	
• 4 to 20 mA	Yes
Connection of actuators	
• for current output 2-conductor connection	Yes
Load impedance (in rated range of output)	
• with current outputs, max.	750 Ω
Cable length	
• Cable length, shielded, max.	500 m
Analog value creation	
Integrations and conversion time/ resolution per channel	
• Resolution with overrange (bit including sign), max.	14 bit
Settling time	
• for resistive load	4 ms
• for capacitive load	40 ms
• for inductive load	40 ms
Errors/accuracies	
Linearity error (relative to output area)	+/- 0.015 %
Temperature error (relative to output area)	+/- 0.005 %/K
Crosstalk between the outputs, min.	-50 dB
Repeat accuracy in settled status at 25 °C (relative to output area)	+/- 0.01 %

	6ES7 135-7TD00-0AB0
Operational limit in overall temperature range	
• Current, relative to output area	+/- 0.15 %
Basic error limit (operational limit at 25 °C)	
• Current, relative to output area	+/- 0.1 %
Interrupts/diagnostics/ status information	
Substitute values connectable	Yes
Alarms	
• Diagnostic alarm	Yes
Diagnostic messages	
• Diagnostic information readable	Yes
• Wire break	Yes
• Short circuit	Yes
Diagnostics indication LED	
• Group error SF (red)	Yes
Galvanic isolation	
Galvanic isolation analog outputs	
• between the channels	No
• between the channels and the backplane bus	Yes
Standards, approvals, certificates	
Use in hazardous areas	
• Type of protection acc. to EN 50020 (CENELEC)	II2 G (1) GD Ex ib[ia] IIC T4 and I M2 Ex ib[ia] I
• Type of protection acc. to KEMA	04 ATEX 1250
Dimensions	
Width	30 mm
Height	129 mm
Depth	136.5 mm
Weight	
Weight, approx.	265 g

SIMATIC ET 200 distributed I/O

ET 200iSP

Analog electronic modules

Technical specifications (continued)

	6ES7 193-7CA00-0AA0	6ES7 193-7CA10-0AA0	6ES7 193-7CB00-0AA0
Standards, approvals, certificates			
CE mark	No	No	Yes
Use in hazardous areas			
• Type of protection acc. to EN 50020 (CENELEC)	No	No	II 2 G and I M2 Ex deib IIC T4; Ex deib I
• Test number KEMA	04 ATEX 2242	04 ATEX 2242	07 ATEX 0205
Dimensions			
Width	60 mm	60 mm	60 mm
Height	190 mm	190 mm	190 mm
Depth	52 mm	52 mm	52 mm
Weight			
Weight, approx.	275 g	275 g	340 g

Ordering data

	Order No.
Analog input modules	
4 AI I 2WIRE HART	6ES7 134-7TD00-0AB0
4 AI I 4WIRE HART	6ES7 134-7TD50-0AB0
4 AI RTD	6ES7 134-7SD51-0AB0
4 AI TC	6ES7 134-7SD00-0AB0
Analog output modules	
4 AO I HART	6ES7 135-7TD00-0AB0
Terminal module	
TM-EM/EM60S (blue screw-type terminals)	6ES7 193-7CA00-0AA0
TM-EM/EM60C (blue spring-loaded terminals)	6ES7 193-7CA10-0AA0
TM-EM/EM60S (black screw-type terminals)	6ES7 193-7CA20-0AA0

Accessories

	Order No.
ET 200iSP manual	
• German	6ES7 152-1AA00-8AA0
• English	6ES7 152-1AA00-8BA0
Connectors	
PROFIBUS connector with active terminating resistor	6ES7 972-0DA60-0XA0
For RS 485-IS circuit; 1.5 Mbit/s	
RS 485-IS coupler	6ES7 972-0AC80-0XA0
Isolating transformer for coupling of PROFIBUS DP and PROFIBUS RS 485-IS	
Labeling sheet	
DIN A4, perforated, each consisting of 10 sheets of 30 strips each, used for electronic modules and 20 strips, used for IM 151	
• petrol	6ES7 193-7BH00-0AA0
• red	6ES7 193-7BD00-0AA0
• yellow	6ES7 193-7BB00-0AA0
• light beige	6ES7 193-7BA00-0AA0
Labels, inscribed	
Ordering unit 1 set with 200 pieces each for slot numbering	
• 10 x slots 1 to 2	8WA8 861-0AB
• 5 x slots 1 to 40	8WA8 861-0AC
Labels, blank	8WA8 848-2AY
Ordering unit 1 set with 200 pieces each for slot numbering	
S7-300 mounting rails	
Standard rail 585 mm	6ES7 390-1AF85-0AA0
Standard rail 885 mm	6ES7 390-1AJ85-0AA0
Stainless steel enclosure	see page 9/250

Overview



- Digital inputs for fail-safe SIMATIC S7 systems
- Can be used in the distributed ET 200iSP I/O device with IM 152-1

The digital electronic module 8 F-DI Ex NAMUR has the following features:

- Suitable for the connection of encoders from the hazardous area
- 8 inputs 1-channel (SIL2/Category 3/PLe) or 4 inputs 2-channel (SIL3/Category 4/PLe)
- Isolated from the power bus/backplane bus
- Suitable for the following sensors:
 - According to IEC 60947-5-6 or NAMUR (with diagnostic evaluation)
 - Wired mechanical contacts (with diagnostic evaluation)
 - Unwired mechanical contacts (with deactivated diagnostics)
- Programmable diagnostic interrupt
- Diagnostic buffer integrated in module
- Firmware update
- Identification data I&M
- Channel-selective passivation
- Supports time stamping
- Can only be used in safety mode

Technical specifications

	6ES7 138-7FN00-0AB0
FH technology	
Module for failsafe applications	Yes
Input current	
from supply voltage L+, max.	150 mA; (int. power bus)
Encoder supply	
Number of outputs	8
Output voltage	8 V DC
Power losses	
Power loss, typ.	1.4 W
Address area	
Occupied address area	
• Outputs	4 byte
• Inputs	6 byte
Digital inputs	
Number/binary inputs	8
Number of NAMUR inputs	8
Input voltage	
• Type of input voltage	DC
Input current	
• for signal "1", typ.	9.5 mA
Input delay (for rated value of input voltage)	
• for standard inputs	
- at "0" to "1", min.	0.7 ms
- at "0" to "1", max.	16 ms; Parameterizable
- at "1" to "0", min.	0.7 ms
- at "1" to "0", max.	16 ms; Parameterizable
Cable length	
• Cable length, shielded, max.	500 m
• Cable length unshielded, max.	200 m

	6ES7 138-7FN00-0AB0
Encoder	
Number of connectable encoders, max.	8
Connectable encoders	
• NAMUR encoder	Yes
NAMUR encoder	
• Input current, for signal "0", max.	1.2 mA
• Input current, for signal "1", min.	2.1 mA
Interrupts/diagnostics/ status information	
Status indicator	Yes
Alarms	
• Diagnostic alarm	Yes; Parameterizable
• Hardware interrupt	No
Diagnostic messages	
• Diagnostic functions	Yes
• Diagnostic information readable	Yes
• Wire break	Yes; NAMUR encoders or single contact with 10 kOhm parallel resistor
• Short circuit	Yes; R load < 150 ohms with NAMUR sensor/sensor and NAMUR changeover contact/sensor to DIN 19234
Diagnostics indication LED	
• Group error SF (red)	Yes
Parameter	
Diagnosis: wire break	channel by channel
Diagnosis: short circuit	channel by channel

SIMATIC ET 200 distributed I/O

ET 200iSP

Fail-safe electronic modules F digital input module

Technical specifications (continued)

6ES7 138-7FN00-0AB0	
Galvanic isolation between the channels and backplane bus	Yes
Galvanic isolation digital inputs	No
• between the channels	Yes
• between the channels and the backplane bus	
Permissible potential difference between different circuits	60 V DC/30 V AC
Isolation Isolation checked with	350 V AC/1 min between the shield and backplane bus connection 350 V AC/1 min between the shield and I/O 2830 V AC/1 min between backplane bus connection and I/O

6ES7 138-7FN00-0AB0	
Standards, approvals, certificates	
CE mark	Yes
Highest safety class achievable in safety mode	
• acc. to IEC 61508	SIL 3
• Performance Level in accordance with EN ISO 13849-1	PLe
Use in hazardous areas	
• Type of protection acc. to EN 50020 (CENELEC)	II 2 G (1) GD Ex ib[ia Ga][ia IIIC Da] IIC T4 GB and I M2 Ex ib[ia Ma] I Mb
• Type of protection acc. to KEMA	10 ATEX 0056
Dimensions	
Width	30 mm
Height	129 mm
Depth	136.5 mm
Weight	
Weight, approx.	288 g

Ordering data

Ordering data	Order No.
F digital input modules	
8 F-DI Ex NAMUR	6ES7 138-7FN00-0AB0
Terminal modules	
TM-EM/EM60S	6ES7 193-7CA00-0AA0
(blue screw-type terminals)	
TM-EM/EM60C	6ES7 193-7CA10-0AA0
(blue spring-loaded terminals)	
TM-EM/EM60S	6ES7 193-7CA20-0AA0
(black screw-type terminals)	
Accessories	
ET 200iSP Manual	
• German	6ES7 152-1AA00-8AA0
• English	6ES7 152-1AA00-8BA0
Cable connector	
PROFIBUS cable connector with active terminating resistor	6ES7 972-0DA60-0XA0
For RS 485-IS electric circuit; 1.5 Mbit/s	
RS 485-IS coupler	6ES7 972-0AC80-0XA0
Isolating transformer for connection of PROFIBUS DP and PROFIBUS RS 485-IS	
Labeling sheet	
DIN A4, perforated, each consisting of 10 sheets of 30 strips each, can be used for electronic modules, and 20 strips each, can be used for IM 151	
• petrol	6ES7 193-7BH00-0AA0
• red	6ES7 193-7BD00-0AA0
• yellow	6ES7 193-7BB00-0AA0
• light beige	6ES7 193-7BA00-0AA0

Order No.

Labels, inscribed	
Ordering unit: 1 set with 200 items each for slot numbering	
• 10 x slots 1 to 2	8WA8 861-0AB
• 5 x slots 1 to 40	8WA8 861-0AC
Labels, not inscribed	8WA8 848-2AY
Ordering unit: 1 set with 200 items each for slot numbering	
Distributed Safety V5.4 programming tool	
Task: Software for configuring fail-safe user programs for SIMATIC S7-300F, S7-400F, ET 200S	
Requirement: STEP 7 V5.3 SP3 and higher	
Floating License	6ES7 833-1FC02-0YA5

Ordering data	Order No.	Order No.	
<p>S7 F Systems RT License</p> <p>For processing safety-related user programs, for one AS 412F/FH, AS 414F/FH or AS 417F/FH</p>	6ES7 833-1CC00-6YX0		
<p>S7 F Systems V6.1</p> <p>Programming and configuring environment for creating and operating safety-related STEP 7 programs for an S7 400H-based target system, Floating License for 1 user, executable under Windows XP Prof SP2/SP3, Windows Server 2003 SP2</p> <p>2 languages (German, English)</p> <p>Type of delivery: Certificate of License as well as software and electronic documentation on CD</p>	6ES7 833-1CC02-0YA5		
<p>SIMATIC Safety Matrix Tool V6.2</p> <p>Creation, configuration, compilation, loading and online monitoring of the Safety Matrix in a SIMATIC PCS 7 environment</p> <p>Including SIMATIC Safety Matrix Viewer for SIMATIC PCS 7, for operation and monitoring of the Safety Matrix in a SIMATIC PCS 7 environment with several operator control levels</p> <p>1 language (English), executes with Windows XP Professional,</p> <p>Type of delivery: Certificate of License and authorization diskette for Safety Matrix Tool and Safety Matrix Viewer; software and electronic documentation on CD</p> <p>Floating License for 1 installation</p> <p>Floating License upgrade from V5.x/V6.x to V6.2</p>	<p>6ES7 833-1SM02-0YA5</p> <p>6ES7 833-1SM02-0YE5</p>		
		<p>SIMATIC Safety Matrix Editor V6.2</p> <p>Creation and checking of the Safety Matrix logic on an external computer without a SIMATIC PCS 7 or STEP 7 environment</p> <p>1 language (English), executes with Windows 2000 Professional or Windows XP Professional, single license for 1 installation</p> <p>Type of delivery: Certificate of License and authorization diskette; software and electronic documentation on CD</p> <p>SIMATIC Safety Matrix Viewer V6.2 for SIMATIC PCS 7</p> <p>Operation and monitoring of the Safety Matrix in the SIMATIC PCS 7 environment with several operator control levels</p> <p>2 languages (English/German), runs under Windows 2000 Professional, Windows XP Professional, Windows 2003 Server</p> <p>Type of delivery: Certificate of License and authorization diskette; software and electronic documentation on CD</p> <p>Floating License for 1 installation</p> <p>Floating License upgrade from V6.x to V6.2</p>	<p>6ES7 833-1SM42-0YA5</p> <p>6ES7 833-1SM62-0YA5</p> <p>6ES7 833-1SM62-0YE5</p>

SIMATIC ET 200 distributed I/O

ET 200iSP

Fail-safe electronic modules F digital output module

Overview



- Digital outputs for fail-safe SIMATIC S7 systems
- Can be used in the distributed ET 200iSP I/O device with IM 152-1

The digital electronic module 4 F-DO Ex 17.4 V/40 mA has the following properties:

- Suitable for the connection of actuators from the hazardous area
- 4 outputs, PP-switching (SIL3/Category 4/PLe)
- Isolated from the power bus/backplane bus
- Max. output current 40 mA
- Rated load voltage 17.4 V DC
- Short-circuit, overload and wire-break monitoring
- Suitable for Ex i solenoid valves, DC current relays and actuators
- To increase the power rating, two digital outputs can be connected in parallel for one actuator
- Programmable diagnostics
- Programmable diagnostic interrupt
- Diagnostic buffer integrated in module
- Firmware update
- Identification data I&M
- Channel-selective passivation
- Can only be used in safety mode

Technical specifications

6ES7 138-7FD00-0AB0	
Input current from load voltage L+ (without load), max.	510 mA; (int. power bus)
Power losses Power loss, typ.	5.3 W; max.
Digital outputs Number/binary outputs	4
Functionality/short-circuit strength • Response threshold, typ.	Yes Depending on the "short-circuit level" parameter
Controlling a digital input	No
No-load voltage U_{ao} (DC)	17.4 V
Internal resistor R_i	167 Ω
Load resistance range • lower limit • upper limit	270 Ω 18 k Ω
Trend key points E • Voltage U_e (DC) • Current I_e	10 V 40 mA
Output voltage • for signal "1", min.	max. 17.4 V
Output current • for signal "0" residual current, max.	10 μ A
Parallel switching of 2 outputs • for increased power • for redundant control of a load	Yes No
Switching frequency • with resistive load, max. • with inductive load, max.	30 Hz 2 Hz
Cable length • Cable length, shielded, max. • Cable length unshielded, max.	500 m 500 m

6ES7 138-7FD00-0AB0	
Interrupts/diagnostics/ status information	
Status indicator	Yes
Substitute values connectable	Yes
Alarms • Diagnostic alarm	Yes; Parameterizable
Diagnostic messages • Diagnostic information readable • Wire break • Short circuit	Yes Yes Yes
Diagnostics indication LED • Group error SF (red) • Status indicator digital output (green)	Yes Yes
Parameter Diagnosis: wire break Diagnosis: short circuit	Yes Yes
Galvanic isolation Galvanic isolation digital outputs • between the channels • between the channels and the backplane bus • between the channels and the load voltage L+	No Yes Yes
Permissible potential difference between different circuits	60V DC/30V AC
Isolation Isolation checked with	370 V for 1 min

Technical specifications (continued)

6ES7 138-7FD00-0AB0	
Standards, approvals, certificates	
CE mark	Yes
Highest safety class achievable in safety mode	
<ul style="list-style-type: none"> • acc. to IEC 61508 • Performance Level in accordance with EN ISO 13849-1 	SIL 3 PLe
Use in hazardous areas	
<ul style="list-style-type: none"> • Type of protection acc. to EN 50020 (CENELEC) • Type of protection acc. to KEMA 	II 2 G (1) GD Ex ib[ia Ga][ia IIIC Da] IIC T4 GB and I M2 Ex ib[ia Ma] I Mb 10 ATEX 0057

6ES7 138-7FD00-0AB0	
Dimensions	
Width	30 mm
Height	129 mm
Depth	136.5 mm
Weight	
Weight, approx.	285 g

Ordering data

	Order No.
Digital output module	
4 F-DO Ex 17.4 V/40 mA	6ES7 138-7FD00-0AB0
Terminal modules	
TM-EM/EM60S	6ES7 193-7CA00-0AA0
(blue screw-type terminals)	
TM-EM/EM60C	6ES7 193-7CA10-0AA0
(blue spring-loaded terminals)	
TM-EM/EM60S	6ES7 193-7CA20-0AA0
(black screw-type terminals)	
Accessories	
ET 200iSP Manual	
<ul style="list-style-type: none"> • German • English 	6ES7 152-1AA00-8AA0 6ES7 152-1AA00-8BA0
Cable connector	
PROFIBUS cable connector with active terminating resistor	6ES7 972-0DA60-0XA0
For RS 485-IS electric circuit; 1.5 Mbit/s	
RS 485-IS coupler	6ES7 972-0AC80-0XA0
Isolating transformer for connection of PROFIBUS DP and PROFIBUS RS 485-IS	
Labeling sheet	
DIN A4, perforated, each consisting of 10 sheets of 30 strips each, can be used for electronic modules, and 20 strips each, can be used for IM 151	
<ul style="list-style-type: none"> • petrol • red • yellow • light beige 	6ES7 193-7BH00-0AA0 6ES7 193-7BD00-0AA0 6ES7 193-7BB00-0AA0 6ES7 193-7BA00-0AA0

Order No.

Labels, inscribed	
Ordering unit: 1 set with 200 items each for slot numbering	
<ul style="list-style-type: none"> • 10 x slots 1 to 2 • 5 x slots 1 to 40 	8WA8 861-0AB 8WA8 861-0AC
Labels, not inscribed	8WA8 848-2AY
Ordering unit: 1 set with 200 items each for slot numbering	
Distributed Safety V5.4 programming tool	
Task: Software for configuring fail-safe user programs for SIMATIC S7-300F, S7-400F, ET 200S	
Requirement: STEP 7 V5.3 SP3 and higher	
Floating License	6ES7 833-1FC02-0YA5

SIMATIC ET 200 distributed I/O

ET 200iSP

Fail-safe electronic modules

F digital output module

Ordering data	Order No.	Order No.
<p>S7 F Systems RT License</p> <p>For processing safety-related user programs, for one AS 412F/FH, AS 414F/FH or AS 417F/FH</p>	6ES7 833-1CC00-6YX0	6ES7 833-1SM42-0YA5
<p>S7 F Systems V6.1</p> <p>Programming and configuring environment for creating and operating safety-related STEP 7 programs for an S7 400H-based target system, Floating License for 1 user, executable under Windows XP Prof SP2/SP3, Windows Server 2003 SP2</p> <p>2 languages (German, English)</p> <p>Type of delivery: Certificate of License as well as software and electronic documentation on CD</p>	6ES7 833-1CC02-0YA5	<p>SIMATIC Safety Matrix Editor V6.2</p> <p>Creation and checking of the Safety Matrix logic on an external computer without a SIMATIC PCS 7 or STEP 7 environment</p> <p>1 language (English), executes with Windows 2000 Professional or Windows XP Professional, single license for 1 installation</p> <p>Type of delivery: Certificate of License and authorization diskette; software and electronic documentation on CD</p>
<p>SIMATIC Safety Matrix Tool V6.2</p> <p>Creation, configuration, compilation, loading and online monitoring of the Safety Matrix in a SIMATIC PCS 7 environment</p> <p>Including SIMATIC Safety Matrix Viewer for SIMATIC PCS 7, for operation and monitoring of the Safety Matrix in a SIMATIC PCS 7 environment with several operator control levels</p> <p>1 language (English), executes with Windows XP Professional,</p> <p>Type of delivery: Certificate of License and authorization diskette for Safety Matrix Tool and Safety Matrix Viewer; software and electronic documentation on CD</p> <p>Floating License for 1 installation</p> <p>Floating License upgrade from V5.x/V6.x to V6.2</p>	<p>6ES7 833-1SM02-0YA5</p> <p>6ES7 833-1SM02-0YE5</p>	<p>SIMATIC Safety Matrix Viewer V6.2 for SIMATIC PCS 7</p> <p>Operation and monitoring of the Safety Matrix in the SIMATIC PCS 7 environment with several operator control levels</p> <p>2 languages (English/German), runs under Windows 2000 Professional, Windows XP Professional, Windows 2003 Server</p> <p>Type of delivery: Certificate of License and authorization diskette; software and electronic documentation on CD</p> <p>Floating License for 1 installation</p> <p>Floating License upgrade from V6.x to V6.2</p> <p>6ES7 833-1SM62-0YA5</p> <p>6ES7 833-1SM62-0YE5</p>

Overview



- Analog inputs for fail-safe SIMATIC S7 systems
- Can be used in the distributed ET 200iSP I/O device with IM 152-1

The analog electronic module 4 F-AI Ex HART has the following properties:

- Suitable for the connection of encoders from the hazardous area
- 4 analog inputs 1-channel (SIL2/Cat.3/PLe) or 4 inputs 2-channel (SIL3/Category 4/PLe, with two 4 F-AI Ex HART modules)
- Electrical isolation between channels and the backplane bus
- Input ranges:
 - 0 to 20 mA
 - 4 to 20 mA
- Suitable for the following sensors:
 - 2-wire transducers
 - HART field devices
- Programmable diagnostics
- Programmable diagnostic interrupt
- Diagnostic buffer integrated in module
- HART communication (HART protocol versions 5, 6, 7)
- Firmware update
- Identification data I&M
- Can only be used in safety mode

Technical specifications

6ES7 138-7FA00-0AB0	
Input current from supply voltage L+, max.	490 mA; (int. power bus)
Output voltage Power supply to the transmitters	
• short-circuit proof	Yes
• Supply current, max.	25 mA; Plus 4 mA per channel
Power losses Power loss, typ.	5.4 W; max.
Address area Address space per module	
• Address space per module, max.	16 byte; 12 bytes in the I area / 4 bytes in the O area
Analog inputs Number of analog inputs	4
Cycle time (all channels) max.	See data in manual
Input ranges	
• Voltage	No
• Current	Yes
• Thermocouple	No
• Resistance thermometer	No
• Resistance	No
Input ranges (rated values), currents • 4 to 20 mA	Yes; and 0 to 20 mA
Cable length • Cable length, shielded, max.	500 m
Analog value creation Measurement principle	integrating (Sigma-Delta)
Integrations and conversion time/ resolution per channel	
• Resolution with overrange (bit including sign), max.	16 bit
• Integration time, parameterizable	Yes
• Interference voltage suppression for interference frequency f1 in Hz	50 / 60 Hz

6ES7 138-7FA00-0AB0	
Smoothing of measured values • Parameterizable	Yes; in 4 stages
• Step: None	Yes; 1 x cycle time
• Step: low	Yes; 4 x cycle time
• Step: Medium	Yes; 32 x cycle time
• Step: High	Yes; 64 x cycle time
Encoder Connection of signal encoders	
• for current measurement as 2-wire transducer	Yes
• Burden of 2-wire transmitter, max.	750 Ω
Errors/accuracies Linearity error (relative to input area)	+/- 0.015 %
Temperature error (relative to input area)	+/- 0.005 %/K
Crosstalk between the inputs, min.	-50 dB
Repeat accuracy in settled status at 25 °C (relative to input area)	+/- 0.015%
Operational limit in overall temperature range • Current, relative to input area	+/- 0.35%
Basic error limit (operational limit at 25 °C) • Current, relative to input area	+/- 0.1 %
Interference voltage suppression for f = n x (f1 +/- 1%), f1 = interference frequency	
• Series mode interference (peak value of interference < rated value of input range), min.	40 dB
• Common mode interference, min.	50 dB

SIMATIC ET 200 distributed I/O

ET 200iSP

Fail-safe electronic modules F analog input module

Technical specifications (continued)

6ES7 138-7FA00-0AB0	
Interrupts/diagnostics/ status information	
Alarms	
• Diagnostic alarm	Yes; Parameterizable
Diagnostic messages	
• Diagnostic information readable	Yes
• Wire break	Yes
• Short circuit	Yes
Diagnostics indication LED	
• Group error SF (red)	Yes
Galvanic isolation	
Galvanic isolation analog inputs	
• between the channels	No
• between the channels and the backplane bus	Yes
• between the channels and the load voltage L+	Yes; Power bus
Permissible potential difference between the inputs (UCM)	60 V DC/30 V AC

6ES7 138-7FA00-0AB0	
Standards, approvals, certificates	
CE mark	Yes
Highest safety class achievable in safety mode	
• acc. to IEC 61508	SIL 3
• Performance Level in accordance with EN ISO 13849-1	PLe
Use in hazardous areas	
• Type of protection acc. to EN 50020 (CENELEC)	II 2 G (1) GD Ex ib[ia Ga][ia IIIC Da] IIC T4 GB and I M2 Ex ib[ia Ma] I Mb
• Type of protection acc. to KEMA	10 ATEX 0058
Dimensions	
Width	30 mm
Height	129 mm
Depth	136.5 mm
Weight	
Weight, approx.	299 g

Ordering data

Ordering data	Order No.
F analog input module	
4 F-AI Ex HART	6ES7 138-7FA00-0AB0
Terminal modules	
TM-EM/EM60S	6ES7 193-7CA00-0AA0
(blue screw-type terminals)	
TM-EM/EM60C	6ES7 193-7CA10-0AA0
(blue spring-loaded terminals)	
TM-EM/EM60S	6ES7 193-7CA20-0AA0
(black screw-type terminals)	
Accessories	
ET 200iSP Manual	
• German	6ES7 152-1AA00-8AA0
• English	6ES7 152-1AA00-8BA0
Cable connector	
PROFIBUS cable connector with active terminating resistor	6ES7 972-0DA60-0XA0
For RS 485-IS electric circuit; 1.5 Mbit/s	
RS 485-IS coupler	6ES7 972-0AC80-0XA0
Isolating transformer for connection of PROFIBUS DP and PROFIBUS RS 485-IS	
Labeling sheet	
DIN A4, perforated, each consisting of 10 sheets of 30 strips each, can be used for electronic modules, and 20 strips each, can be used for IM 151	
• petrol	6ES7 193-7BH00-0AA0
• red	6ES7 193-7BD00-0AA0
• yellow	6ES7 193-7BB00-0AA0
• light beige	6ES7 193-7BA00-0AA0

Order No.

Labels, inscribed	
Ordering unit: 1 set with 200 items each for slot numbering	
• 10 x slots 1 to 2	8WA8 861-0AB
• 5 x slots 1 to 40	8WA8 861-0AC
Labels, not inscribed	8WA8 848-2AY
Ordering unit: 1 set with 200 items each for slot numbering	
Distributed Safety V5.4 programming tool	
Task: Software for configuring fail-safe user programs for SIMATIC S7-300F, S7-400F, ET 200S	
Requirement: STEP 7 V5.3 SP3 and higher	
Floating License	6ES7 833-1FC02-0YA5
S7 F Systems RT License	6ES7 833-1CC00-6YX0
For processing safety-related user programs, for one AS 412F/FH, AS 414F/FH or AS 417F/FH	

Ordering data	Order No.	Order No.	
<p>S7 F Systems V6.1</p> <p>Programming and configuring environment for creating and operating safety-related STEP 7 programs for an S7 400H-based target system, Floating License for 1 user, executable under Windows XP Prof SP2/SP3, Windows Server 2003 SP2</p> <p>2 languages (German, English)</p> <p>Type of delivery: Certificate of License as well as software and electronic documentation on CD</p>	<p>6ES7 833-1CC02-0YA5</p>	<p>SIMATIC Safety Matrix Editor V6.2</p> <p>Creation and checking of the Safety Matrix logic on an external computer without a SIMATIC PCS 7 or STEP 7 environment</p> <p>1 language (English), executes with Windows 2000 Professional or Windows XP Professional, single license for 1 installation</p> <p>Type of delivery: Certificate of License and authorization diskette; software and electronic documentation on CD</p>	<p>6ES7 833-1SM42-0YA5</p>
<p>SIMATIC Safety Matrix Tool V6.2</p> <p>Creation, configuration, compilation, loading and online monitoring of the Safety Matrix in a SIMATIC PCS 7 environment</p> <p>Including SIMATIC Safety Matrix Viewer for SIMATIC PCS 7, for operation and monitoring of the Safety Matrix in a SIMATIC PCS 7 environment with several operator control levels</p> <p>1 language (English), executes with Windows XP Professional,</p> <p>Type of delivery: Certificate of License and authorization diskette for Safety Matrix Tool and Safety Matrix Viewer; software and electronic documentation on CD</p> <p>Floating License for 1 installation</p> <p>Floating License upgrade from V5.x/V6.x to V6.2</p>	<p>6ES7 833-1SM02-0YA5</p> <p>6ES7 833-1SM02-0YE5</p>	<p>SIMATIC Safety Matrix Viewer V6.2 for SIMATIC PCS 7</p> <p>Operation and monitoring of the Safety Matrix in the SIMATIC PCS 7 environment with several operator control levels</p> <p>2 languages (English/German), runs under Windows 2000 Professional, Windows XP Professional, Windows 2003 Server</p> <p>Type of delivery: Certificate of License and authorization diskette; software and electronic documentation on CD</p> <p>Floating License for 1 installation</p> <p>Floating License upgrade from V6.x to V6.2</p>	<p>6ES7 833-1SM62-0YA5</p> <p>6ES7 833-1SM62-0YE5</p>

SIMATIC ET 200 distributed I/O

ET 200iSP

ET 200iSP watchdog module

Overview



- The watchdog module will be plugged onto the (to be ordered separately) associated terminal module (screw connection or spring-loaded connection).
- Modules can be replaced under potentially explosive conditions during runtime.

Technical specifications

6ES7 138-7BB00-0AB0	
Supply voltage	
permissible range, lower limit (DC)	20.4 V
permissible range, upper limit (DC)	28.8 V
Digital inputs	
Number/binary inputs	0
Dimensions	
Width	30 mm
Height	129 mm
Depth	136.5 mm

Ordering data

Order No.

Watchdog module	6ES7 138-7BB00-0AB0
Terminal module	
TM-EM/EM60S (blue screw-type terminals)	6ES7 193-7CA00-0AA0
TM-EM/EM60C (blue spring-loaded terminals)	6ES7 193-7CA10-0AA0
TM-EM/EM60S (black screw-type terminals)	6ES7 193-7CA20-0AA0
Accessories	
ET 200iSP Manual	
• German	6ES7 152-1AA00-8AA0
• English	6ES7 152-1AA00-8BA0
Connectors	
PROFIBUS connector with active terminating resistor For RS485-IS circuit; 1.5 Mbit/s	6ES7 972-0DA60-0XA0
RS 485-IS Coupler Isolating transformer for coupling of PROFIBUS DP and PROFIBUS RS 485-IS	6ES7 972-0AC80-0XA0
Labeling sheet DIN A4, perforated, each consisting of 10 sheets of 30 strips each, used for electronic modules and 20 strips, used for IM 151	
• Petrol	6ES7 193-7BH00-0AA0
• Red	6ES7 193-7BD00-0AA0
• Yellow	6ES7 193-7BB00-0AA0
• Light beige	6ES7 193-7BA00-0AA0
Labels, inscribed Ordering unit 1 set with 200 pieces each for slot numbering	
• 10 x slots 1 to 2	8WA8 861-0AB
• 5 x slots 1 to 40	8WA8 861-0AC
Labels, blank Ordering unit 1 set with 200 pieces each for slot numbering	8WA8 848-2AY
S7-300 mounting rails	
Standard Rail 585 mm	6ES7 390-1AF85-0AA0
Standard Rail 885 mm	6ES7 390-1AJ85-0AA0
Stainless steel enclosure	see page 9/250

Overview



- The reserve module is plugged onto the relevant terminal module (to be ordered separately; screw-type or spring-loaded connection).
- Modules can be replaced under potentially explosive conditions during runtime.

Technical specifications

6ES7 138-7AA00-0AA0		6ES7 138-7AA00-0AA0	
Standards, approvals, certificates		Dimensions	
CE mark	Yes	Width	30 mm
Use in hazardous areas		Height	129 mm
• Type of protection acc. to EN 50020 (CENELEC)	II 2 G EEx ib IIC T4	Depth	136.5 mm
• Test number KEMA	04 ATEX 1251	Weight	
		Weight, approx.	180 g

6ES7 193-7CA00-0AA0		6ES7 193-7CA10-0AA0		6ES7 193-7CB00-0AA0	
Standards, approvals, certificates					
CE mark	No	No		Yes	
Use in hazardous areas					
• Type of protection acc. to EN 50020 (CENELEC)	No	No		II 2 G and I M2 Ex deib IIC T4; Ex deib I	
• Test number KEMA	04 ATEX 2242	04 ATEX 2242		07 ATEX 0205	
Dimensions					
Width	60 mm	60 mm		60 mm	
Height	190 mm	190 mm		190 mm	
Depth	52 mm	52 mm		52 mm	
Weight					
Weight, approx.	275 g	275 g		340 g	

SIMATIC ET 200 distributed I/O

ET 200iSP

Reserve module

Ordering data	Order No.	Order No.
Reserve module	6ES7 138-7AA00-0AA0	
Terminal module		
TM-EM/EM 60S (blue screw-type terminals)	6ES7 193-7CA00-0AA0	
TM-EM/EM 60C (blue spring-loaded terminals)	6ES7 193-7CA10-0AA0	
TM-RM/RM 60S (black screw-type terminals); for accommodating digital output module 2 DO relay and reserve modules; screw-type terminal	6ES7 193-7CB00-0AA0	
Accessories		
ET 200iSP manual • German • English	6ES7 152-1AA00-8AA0 6ES7 152-1AA00-8BA0	
Connectors PROFIBUS connector with active terminating resistor For RS 485-IS circuit; 1.5 Mbit/s	6ES7 972-0DA60-0XA0	
RS 485-IS coupler Isolating transformer for coupling of PROFIBUS DP and PROFIBUS RS 485-IS	6ES7 972-0AC80-0XA0	
		Labeling sheet DIN A4, perforated, each consisting of 10 sheets of 30 strips each, used for electronic modules and 20 strips, used for IM 151 • petrol • red • yellow • light beige 6ES7 193-7BH00-0AA0 6ES7 193-7BD00-0AA0 6ES7 193-7BB00-0AA0 6ES7 193-7BA00-0AA0
		Labels, inscribed Ordering unit 1 set with 200 pieces each for slot numbering • 10 x slots 1 to 2 • 5 x slots 1 to 40 8WA8 861-0AB 8WA8 861-0AC
		Labels, blank Ordering unit 1 set with 200 pieces each for slot numbering 8WA8 848-2AY
		S7-300 mounting rails Standard rail 585 mm Standard rail 885 mm 6ES7 390-1AF85-0AA0 6ES7 390-1AJ85-0AA0
		Stainless steel enclosure see page 9/250

Overview

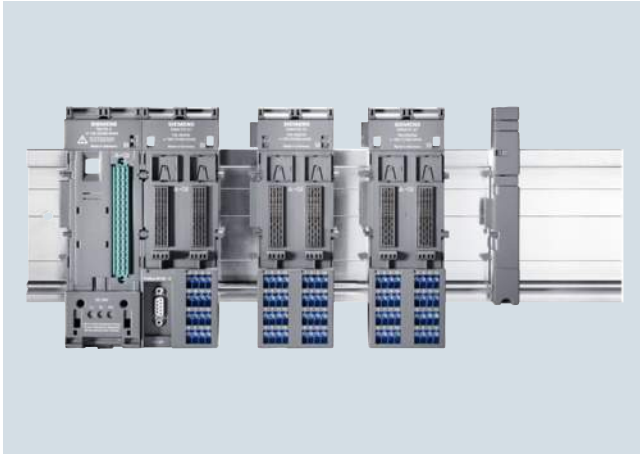

- Mechanical modules for accommodating the power supply unit, interface and electronic modules
- For setting up the fixed wiring via self-assembling voltage buses
- Different versions for accommodating electronic modules
- Automatic encoding of the electronic modules
- Self-assembling shielding of the backplane bus for high data security
- Alternatively with screw or spring-loaded terminals

Ordering data

TM-PS terminal modules

TM-PS A
for accommodating a 24 V DC
power supply

Order No.

6ES7 193-7DA10-0AA0

TM-PS A UC
for accommodating a 110/230 V AC
power supply

6ES7 193-7DA20-0AA0

TM-PS B
for accommodating an additional,
redundant 24 V DC power supply

6ES7 193-7DB10-0AA0

TM-PS B UC
for accommodating an additional,
redundant 110/230 V AC power
supply

6ES7 193-7DB20-0AA0

TM-IM/xx terminal modules

TM-IM/EM60S
for hazardous environments;
for accommodating the IM152-1
and an electronic module,
including power termination module;
screw terminals, blue

6ES7 193-7AA00-0AA0

TM-IM/EM60S
for non-hazardous environments;
for accommodating the IM152-1
and an electronic module,
including power termination module;
screw terminals, black

6ES7 193-7AA20-0AA0

TM-IM/EM60C
for hazardous environments;
for accommodating the IM152-1
and an electronic module,
including power termination module;
spring-loaded terminals, blue

6ES7 193-7AA10-0AA0

TM-IM/IM
for accommodating two IM152-1
modules in redundant mode,
including power termination module

6ES7 193-7AB00-0AA0

TM-EM/EM terminal modules

TM-EM/EM60S
for hazardous environments;
for accommodating two electronic
modules, screw terminals, blue

Order No.

6ES7 193-7CA00-0AA0

TM-EM/EM60S
for non-hazardous environments;
for accommodating two electronic
modules, screw terminals, black

6ES7 193-7CA20-0AA0

TM-EM/EM60C
for hazardous environments;
for accommodating two electronic
modules, spring-loaded terminals,
blue

6ES7 193-7CA10-0AA0

TM-RM/RM terminal module

TM-RM/RM
for accommodating two relay
modules, screw terminals

6ES7 193-7CB00-0AA0

SIMATIC ET 200 distributed I/O

ET 200iSP

RS 485-IS coupler

Overview



- Coupler for converting PROFIBUS DP into PROFIBUS RS485-IS intrinsically safe (protection type intrinsically safe i)
- Required for connecting intrinsically safe PROFIBUS DP stations (e.g. ET 200iS, ET 200iSP) and on all third-party devices that have an Ex i DP connection
- Additional use as a repeater in the hazardous area
- Acts as a safety barrier
- Passive bus node, configuration not required
- Certified according to ATEX 100a

Technical specifications

Technical specifications RS 485-IS Coupler

Dimensions and weight

Dimensions W x H x D (mm) 80 x 125 x 130

Weight Approx. 500 g

Technical specifications – General

Degree of protection IP20

Ambient temperature - 20 °C ... + 60 °C

Standards and approvals

- | | |
|---|--|
| <ul style="list-style-type: none"> • PROFIBUS • EU directive • CENELEC • UL and CSA | <p>IEC 61784-1: 2002 Ed1 CP 3/1</p> <p>94/9/EG (ATEX 100a)</p> <p>II 3 (2) G EEx nA[ib] IIC T4</p> <p>Class I, Division2, Group A, B, C, D T4
Class I Zone 2, Group IIC T4
AIS Class I, Division 1, Group A, B, C, D
[Aexib] IIC, Class I, Zone1, 2, Group IIC</p> |
| <ul style="list-style-type: none"> • FM | <p>Class I, Division2, Group A, B, C, D T4
Class I Zone 2, Group IIC T4
AIS Class I, Division 1, Group A, B, C, D
[Aexib] IIC, Class I, Zone1, 2, Group IIC</p> |
| <ul style="list-style-type: none"> • IEC • CE | <p>IEC61131-2, Part 2</p> <p>Conforming with 89/336/EWG
Conforming with 73/23/EWG</p> |
| <ul style="list-style-type: none"> • Ship-building certification | <p>Classification companies</p> <ul style="list-style-type: none"> • ABS (American Bureau of Shipping) • BV (Bureau Veritas) • DNV (Det Norske Veritas) • GL (Germanischer Lloyd) • LRD (Lloyds Register of Shipping) • Class NK (Nippon Kaiji Kyokai) |

Module-specific specifications

Data transmission rate on PROFIBUS DP, PROFIBUS RS 485-IS 9.6; 19.2; 45.45; 93.75; 187.5; 500 kbit/s
1.5 Mbit/s

Bus protocol PROFIBUS DP

Technical specifications (continued)

Technical specifications RS 485-IS Coupler		
Voltages, currents, potentials		
Nominal supply voltage for RS 485-IS coupler	24 V DC (20.4 ... 28.8 V)	
• Polarity reversal protection	Yes	
• Voltage drop bypass	Min. 5 ms	
Potential isolation for 24 V power supply		
• to PROFIBUS DP	Yes	
- tested with	500 V DC	
• to PROFIBUS RS 485-IS	Yes	
- tested with	500 V AC	
Current consumption RS 485-IS coupler (24 V DC), max.	150 mA	
Power loss of the module, typically	3 Watts	
Status, alarms, diagnostics		
Status display	No	
Alarms	None	
Diagnostic functions		
• Bus monitoring PROFIBUS DP (primary)	Yes Yellow LED "DP1"	
• Bus monitoring PROFIBUS RS 485-IS (secondary)	Yellow LED "DP2"	
• Monitoring 24 V power supply	Green LED "ON"	
Technical safety notice		
V _{DC}	±4.2 V	
I _{SC}	±93 mA	
P ₀	0.1 Watts	
V _{max}	±4.2 V	
L _I	0	
C _i	0	
U _m	250 V AC	
T _a	-25 ... +60 °C	
RS 485-IS segment		
Permitted cable length on a single line	RS 485-IS	DP Ex i
• 9,6 ... 187.5 kbit/s	1,000 m	200 m
• 500 kbit/s	400 m	200 m
• 1.5 Mbit/s	200 m	200 m
Number of PROFIBUS DP nodes that can be connected, max.	31	16
PROFIBUS RS 485-IS bus termination switch	integrated, can be added	

Ordering data

RS 485-IS coupler

Isolating transformer for coupling of PROFIBUS DP and PROFIBUS RS 485-IS

Order No.

6ES7 972-0AC80-0XA0

Accessories

PROFIBUS connector with active terminating resistor

For RS 485-IS circuit; 1.5 Mbit/s

6ES7 972-0DA60-0XA0

PROFIBUS cable connector

for the intrinsically safe PROFIBUS, 1.5 Mbit/s

6ES7 972-0BA30-0XA0

Mounting rail

160 mm

482 mm

530 mm

830 mm

2000 mm

PROFIBUS FastConnect bus cable

Standard type with special design for quick assembly, 2-core, shielded, sold by the meter, max. delivery unit 1000 m, minimum ordering quantity 20 m

Order No.

6ES7 390-1AB60-0AA0

6ES7 390-1AE80-0AA0

6ES7 390-1AF30-0AA0

6ES7 390-1AJ30-0AA0

6ES7 390-1BC00-0AA0

6XV1 830-0EH10

SIMATIC ET 200 distributed I/O

ET 200iSP

Stainless steel wall enclosure

Design



ET 200iSP modules can also be installed in stainless steel wall housings designed to meet more exacting protection requirements. The housings are available in various different sizes. They comply with degree of protection IP65 and can also be used in Ex zones 1 and 21.

Ordering data

Order No.

Stainless steel enclosure IP65, protection class Ex e, suitable for Ex zones 1 and 21

Empty enclosure without installation of modules, for use in gas area (zones 1 and 2), IP65

Enclosure with hinged cover 650 x 450 x 230

For the installation of no more than 15 ET 200iSP modules, for use in gas area, for temperature range -20 °C to +70 °C, with equipotential bonding rail and cable inlets:

- 2 x M32 for infeed, 4 x M20 for bus cables, 39 x M16 (3 rows) for signal lines and 2 rows of blanking plugs, all cable inlets of black plastic **6DL2 804-0AD30**
- 2 x M32 for infeed, 4 x M20 for bus cables, 39 x M16 (3 rows) for signal lines and 2 rows of blanking plugs, cable inlets M20 and M16 of blue plastic, M32 of black plastic **6DL2 804-0AD32**
- 2 x M32 for infeed, 4 x M20 for bus cables, 36 x M20 (3 rows) for signal lines and 2 rows of blanking plugs, cable inlets M20 of blue plastic, M32 of black plastic **6DL2 804-0AD42**
- 2 x M32 for infeed, 4 x M20 for bus cables, 65 x M16 (5 rows) for signal lines, all cable inlets of black plastic **6DL2 804-0AD50**
- 2 x M32 for infeed, 4 x M20 for bus cables, 65 x M16 (5 rows) for signal lines, all cable inlets of metal, for extended temperature range -40 °C to +70 °C **6DL2 804-0AD51**
- 2 x M32 for infeed, 4 x M20 for bus cables, 65 x M16 (5 rows) for signal lines, cable inlets M20 and M16 of blue plastic, M32 of black plastic **6DL2 804-0AD52**
- 2 x M32 for infeed, 4 x M20 for bus cables, 60 x M20 (5 rows) for signal lines, cable inlets M20 of blue plastic, M32 of black plastic **6DL2 804-0AD62**

Order No.

Enclosure with hinged cover 950 x 450 x 230

For the installation of no more than 25 ET 200iSP modules, for use in gas area, for temperature range -20 °C to +70 °C, with equipotential bonding rail and cable inlets:

- 2 x M32 for infeed, 4 x M20 for bus cables, 66 x M16 (3 rows) for signal lines and 2 rows of blanking plugs, all cable inlets of black plastic **6DL2 804-0AE30**
- 2 x M32 for infeed, 4 x M20 for bus cables, 66 x M16 (3 rows) for signal lines and 2 rows of blanking plugs, cable inlets M20 and M16 of blue plastic, M32 of black plastic **6DL2 804-0AE32**
- 2 x M32 for infeed, 4 x M20 for bus cables, 57 x M20 (3 rows) for signal lines and 2 rows of blanking plugs, cable inlets M20 of blue plastic, M32 of black plastic **6DL2 804-0AE42**
- 2 x M32 for infeed, 4 x M20 for bus cables, 110 x M16 (5 rows) for signal lines, all cable inlets of black plastic **6DL2 804-0AE50**
- 2 x M32 for infeed, 4 x M20 for bus cables, 110 x M16 (5 rows) for signal lines, all cable inlets of metal, for extended temperature range -40 °C to +70 °C **6DL2 804-0AE51**
- 2 x M32 for infeed, 4 x M20 for bus cables, 110 x M16 (5 rows) for signal lines, cable inlets M20 and M16 of blue plastic, M32 of black plastic **6DL2 804-0AE52**
- 2 x M32 for infeed, 4 x M20 for bus cables, 90 x M20 (5 rows) for signal lines, cable inlets M20 of blue plastic, M32 of black plastic **6DL2 804-0AE62**

Ordering data	Order No.	Order No.
<p>Empty enclosure without installation of modules, for use in dusty area (zones 21 and 22), IP65</p> <p>Enclosure with hinged cover 650 x 450 x 230 For the installation of no more than 15 ET 200iSP modules, for use in dusty area, for temperature range -20 °C to +70 °C, with equipotential bonding rail and cable inlets:</p> <ul style="list-style-type: none"> • 2 x M32 for infeed, 4 x M20 for bus cables, 39 x M16 (3 rows) for signal lines and 2 rows of blanking plugs, all cable inlets of black plastic • 2 x M32 for infeed, 4 x M20 for bus cables, 65 x M16 (5 rows) for signal lines, all cable inlets of black plastic 	<p>6DL2 804-0DD30</p> <p>6DL2 804-0DD50</p>	<p>Enclosure with hinged cover 950 x 450 x 230 For the installation of no more than 25 ET 200iSP modules, for use in gas area, for temperature range -20 °C to +70 °C, with equipotential bonding rail and cable inlets:</p> <ul style="list-style-type: none"> • 2 x M32 for infeed, 4 x M20 for bus cables, 66 x M16 (3 rows) for signal lines and 2 rows of blanking plugs, all cable inlets of black plastic • 2 x M32 for infeed, 4 x M20 for bus cables, 66 x M16 (3 rows) for signal lines and 2 rows of blanking plugs, cable inlets M20 and M16 of blue plastic, M32 of black plastic • 2 x M32 for infeed, 4 x M20 for bus cables, 57 x M20 (3 rows) for signal lines and 2 rows of blanking plugs, cable inlets M20 of blue plastic, M32 of black plastic • 2 x M32 for infeed, 4 x M20 for bus cables, 110 x M16 (5 rows) for signal lines, all cable inlets of black plastic • 2 x M32 for infeed, 4 x M20 for bus cables, 110 x M16 (5 rows) for signal lines, cable inlets M20 and M16 of blue plastic, M32 of black plastic • 2 x M32 for infeed, 4 x M20 for bus cables, 90 x M20 (5 rows) for signal lines, cable inlets M20 of blue plastic, M32 of black plastic <p>6DL2 804-1AE30</p> <p>6DL2 804-1AE32</p> <p>6DL2 804-1AE42</p> <p>6DL2 804-1AE50</p> <p>6DL2 804-1AE52</p> <p>6DL2 804-1AE62</p>
<p>Enclosure with hinged cover 950 x 450 x 230 For the installation of no more than 25 ET 200iSP modules, for use in dusty area, for temperature range -20 °C to +70 °C, with equipotential bonding rail and cable inlets:</p> <ul style="list-style-type: none"> • 2 x M32 for infeed, 4 x M20 for bus cables, 66 x M16 (3 rows) for signal lines and 2 rows of blanking plugs, all cable inlets of black plastic • 2 x M32 for infeed, 4 x M20 for bus cables, 110 x M16 (5 rows) for signal lines, all cable inlets of black plastic 	<p>6DL2 804-0DE30</p> <p>6DL2 804-0DE50</p>	
<p>Enclosure with installation of ET 200iSP modules, for use in gas area (zones 1 and 2), IP65¹⁾</p> <p>Enclosure with hinged cover 650 x 450 x 230 For the installation of no more than 15 ET 200iSP modules, for use in gas area, for temperature range -20 °C to +70 °C, with equipotential bonding rail and cable inlets:</p> <ul style="list-style-type: none"> • 2 x M32 for infeed, 4 x M20 for bus cables, 39 x M16 (3 rows) for signal lines and 2 rows of blanking plugs, all cable inlets of black plastic • 2 x M32 for infeed, 4 x M20 for bus cables, 39 x M16 (3 rows) for signal lines and 2 rows of blanking plugs, cable inlets M20 and M16 of blue plastic, M32 of black plastic • 2 x M32 for infeed, 4 x M20 for bus cables, 36 x M20 (3 rows) for signal lines and 2 rows of blanking plugs, cable inlets M20 of blue plastic, M32 of black plastic • 2 x M32 for infeed, 4 x M20 for bus cables, 65 x M16 (5 rows) for signal lines, all cable inlets of black plastic • 2 x M32 for infeed, 4 x M20 for bus cables, 65 x M16 (5 rows) for signal lines, cable inlets M20 and M16 of blue plastic, M32 of black plastic • 2 x M32 for infeed, 4 x M20 for bus cables, 60 x M20 (5 rows) for signal lines, cable inlets M20 of blue plastic, M32 of black plastic 	<p>6DL2 804-1AD30</p> <p>6DL2 804-1AD32</p> <p>6DL2 804-1AD42</p> <p>6DL2 804-1AD50</p> <p>6DL2 804-1AD52</p> <p>6DL2 804-1AD62</p>	<p>Enclosure with installation of ET 200iSP modules, for use in dusty area (zones 21 and 22), IP65¹⁾</p> <p>Enclosure with hinged cover 650 x 450 x 230 For the installation of no more than 15 ET 200iSP modules, for use in dusty area, for temperature range -20 °C to +70 °C, with equipotential bonding rail and cable inlets:</p> <ul style="list-style-type: none"> • 2 x M32 for infeed, 4 x M20 for bus cables, 39 x M16 (3 rows) for signal lines and 2 rows of blanking plugs, all cable inlets of black plastic • 2 x M32 for infeed, 4 x M20 for bus cables, 65 x M16 (5 rows) for signal lines, all cable inlets of black plastic <p>6DL2 804-1DD30</p> <p>6DL2 804-1DD50</p>

¹⁾ The ET 200iSP components must be ordered separately

SIMATIC ET 200 distributed I/O

ET 200iSP

Stainless steel wall enclosure

Ordering data	Order No.	Ordering data	Order No.
<p>Enclosure with hinged cover 950 x 450 x 230 For the installation of no more than 25 ET 200iSP modules, for use in dusty area, for temperature range -20 °C to +70 °C, with equipotential bonding rail and cable inlets:</p> <ul style="list-style-type: none"> • 2 x M32 for infeed, 4 x M20 for bus cables, 66 x M16 (3 rows) for signal lines and 2 rows of blanking plugs, all cable inlets of black plastic • 2 x M32 for infeed, 4 x M20 for bus cables, 110 x M16 (5 rows) for signal lines, all cable inlets of black plastic 	<p>6DL2 804-1DE30</p> <p>6DL2 804-1DE50</p>	<p>Enclosure with hinged cover 950 x 450 x 230 For the installation of no more than 25 ET 200iSP modules, for use in gas area, for temperature range -20 °C to +70 °C, with equipotential bonding rail and cable inlets:</p> <ul style="list-style-type: none"> • 2 x M32 for infeed, 4 x M20 for bus cables, 66 x M16 (3 rows) for signal lines and 2 rows of blanking plugs, all cable inlets of black plastic • 2 x M32 for infeed, 4 x M20 for bus cables, 110 x M16 (5 rows) for signal lines, all cable inlets of black plastic 	<p>6DL2 804-2AE30</p> <p>6DL2 804-2AE50</p>
<p>Enclosure with installation of ET 200iSP and AirLINE EX modules, for use in gas area (zones 1 and 2), IP65²⁾</p> <p>Enclosure with hinged cover 650 x 450 x 230 For the installation of no more than 15 ET 200iSP modules, for use in gas area, for temperature range -20 °C to +70 °C, with equipotential bonding rail and cable inlets:</p> <ul style="list-style-type: none"> • 2 x M32 for infeed, 4 x M20 for bus cables, 39 x M16 (3 rows) for signal lines and 2 rows of blanking plugs, all cable inlets of black plastic • 2 x M32 for infeed, 4 x M20 for bus cables, 65 x M16 (5 rows) for signal lines, all cable inlets of black plastic 	<p>6DL2 804-2AD30</p> <p>6DL2 804-2AD50</p>	<p>Enclosure with installation of ET 200iSP and AirLINE EX modules, for use in dusty area (zones 21 and 22), IP65²⁾</p> <p>Enclosure with hinged cover 950 x 450 x 230 For the installation of no more than 25 ET 200iSP modules, for use in dusty area, for temperature range -20 °C to +70 °C, with equipotential bonding rail and cable inlets:</p> <ul style="list-style-type: none"> • 2 x M32 for infeed, 4 x M20 for bus cables, 110 x M16 (5 rows) for signal lines, all cable inlets of black plastic 	<p>6DL2 804-2DE50</p>
		<p>Special configurations See the section entitled "Options".</p>	

²⁾ The AirLINE Ex components (see Catalog ST PCS 7.1, Add-ons for SIMATIC PCS 7) and the ET 200iSP components must be ordered separately

Options

Special configurations

For all configurations which deviate from the described standard configurations the order no. **6DL5 711-8AB** must be listed as an additional order number alongside one of the specified basic order numbers.

The following additional information must be appended to the order number:

- Specification/description of the supplementary service and/or
- Reference to an offer

Overview

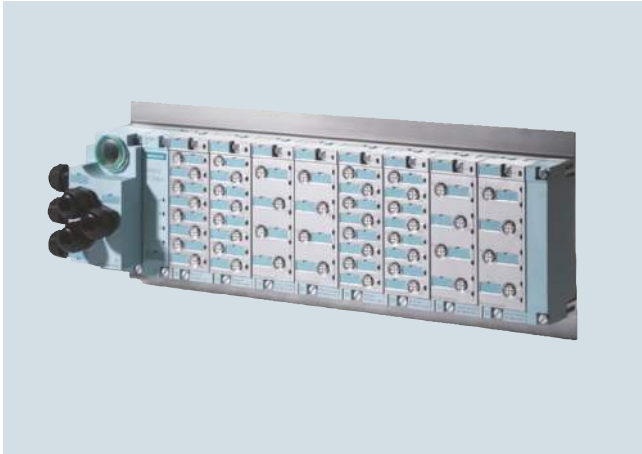

- Distributed I/O system with IP65/67 degree of protection for cabinet-free use at the machine.
- Small, multifunctional complete solution: Digital inputs/outputs, fail-safe modules, motor starters up to 5.5 kW, etc.
- Communication over PROFIBUS or PROFINET
- Mixed arrangement of fail-safe and standard modules in the same station
- Freely selectable connection technique: Direct, ECOFAST or M12 7/8"
- Power module for easy implementation of load groups
- Module replacement during operation (hot swapping)
- Easy installation as well as permanent wiring
- Transmission rate for PROFIBUS DP up to 12 Mbit/s
- Extensive diagnostics: Module-specific or channel-specific
- Intelligent motor starters for starting and protection of motors and loads up to 5.5 kW
 - Versions: Direct and reversing starters - Standard and High-Feature
- Fail-safe motor starters
- Fail-safe modules with safety-related signal processing according to PROFIsafe
- Frequency converters
- RFID communication modules
- Pneumatic interface modules

Technical specifications

General technical specifications	
Electronic modules	<ul style="list-style-type: none"> • Digital inputs/outputs • Analog inputs • Analog outputs
Motor starter	
Cables and connections	M12 and M8 round connector with standard assignment for actuator/sensor
Transmission rate, max.	12 Mbit/s (PROFIBUS DP), 100 Mbit/s (PROFINET IO)
Supply voltage	24 V DC
Current consumption of one ET 200pro (internal and encoder supply, non-switched voltage), up to 55 °C, max.	≤ 5 A
Current consumption of one ET 200pro per infeed (IM, PM, switched voltage, up to 55 °C, max.)	10 A
For overall configuration with looping through (several ET 200pro), up to 55 °C, max.	16 A (with connecting module, directly)
Degree of protection	IP65/66/IP67 for interface, digital and analog modules
Material	Thermoplastic (reinforced with glass fiber)
Ambient conditions	
Temperature	from 0 ... 55 °C (-25 °C on request)
Relative humidity	from 5 ... 100%
Atmospheric pressure	from 795 ... 1080 hPa
Mechanical stress	
• Vibrations	Vibration test conforming to IEC 60068, Part 2-6 (sinusoidal) <ul style="list-style-type: none"> • Constant acceleration 5 g, occasionally 10 g for interface, digital and analog modules • 2 g motor starters
• Shock	Shock test according to IEC 680068 Part 2 - 27, half-sine, 30 g, 18 ms duration for interface, digital and analog modules <ul style="list-style-type: none"> • 15 g, 11 ms duration for motor starters
Approvals	UL, CSA or cULus

SIMATIC ET 200 distributed I/O

ET 200pro

Interface modules IM 154-1 and IM 154-2

Overview



Interface modules for handling communication between the ET 200pro and the higher-level master over PROFIBUS DP.

Technical specifications

	6ES7 154-1AA01-0AB0	6ES7 154-2AA01-0AB0
General information		
Vendor identification (VendorID)	8118H	8119H
Supply voltage		
Rated value (DC)	24 V	24 V
24 V DC	Yes	Yes
permissible range, lower limit (DC)	20.4 V	20.4 V
permissible range, upper limit (DC)	28.8 V	28.8 V
Reverse polarity protection	Yes; against destruction	Yes; against destruction
Short-circuit protection	Yes; over exchangeable fuses	Yes; over exchangeable fuses
Input current		
from supply voltage 1L+, max.	200 mA	200 mA
Power losses		
Power loss, typ.	5 W	5 W
Address area		
Addressing volume		
• Outputs	244 byte	244 byte
• Inputs	244 byte	244 byte
Interfaces		
PROFIBUS DP		
• Automatic detection of transmission speed	Yes	Yes
1st interface		
Type of interface	PROFIBUS DP	PROFIBUS DP
Physics	RS 485	RS 485
Functionality		
• DP slave	Yes	Yes
DP slave		
• Transmission rate, min.	9.6 kbit/s	9.6 kbit/s
• Transmission rate, max.	12 Mbit/s	12 Mbit/s
• Services		
- SYNC/FREEZE	Yes	Yes
- Direct data exchange (slave-to-slave communication)	Yes	Yes
Interrupts/diagnostics/ status information		
Diagnostics indication LED		
• Bus fault BF (red)	Yes	Yes
• Group error SF (red)	Yes	Yes
• Monitoring 24 V voltage supply ON (green)	Yes	Yes
• Load voltage monitoring DC 24 V (green)	Yes	Yes

Technical specifications (continued)

	6ES7 154-1AA01-0AB0	6ES7 154-2AA01-0AB0
Parameter		
DPV1 operation	possible	possible
Hardware interrupt	Parameterizable	Parameterizable
Swapping interrupt	Parameterizable	Parameterizable
Startup if setpoint not equal to actual configuration	Parameterizable	Parameterizable
Galvanic isolation		
between supply voltage and electronics	Yes	Yes
Isolation		
Isolation checked with	500 V DC	500 V DC
Degree and class of protection		
IP67	Yes	Yes
Ambient conditions		
Operating temperature		
• Min.	-25 °C	-25 °C
• max.	55 °C	55 °C
Storage/transport temperature		
• Min.	-40 °C	-40 °C
• max.	70 °C	70 °C
Dimensions		
Width	90 mm	90 mm
Height	130 mm	130 mm
Depth	59.3 mm	59.3 mm
Weight		
Weight, approx.	375 g	375 g

Ordering data

	Order No.		Order No.
IM154-1 interface module	6ES7 154-1AA01-0AB0	Accessories for CM IM DP ECOFAST PROFIBUS ECOFAST hybrid cable, preassembled With 2 ECOFAST connectors, trailing-type cable with 2 x CU 0.64 mm ² and 4 x Cu 1.5 mm ² , in various lengths:	
For ET 200pro; for communication between ET 200pro and higher-level masters over PROFIBUS DP.			
IM154-2 High Feature interface module	6ES7 154-2AA01-0AB0	1.5 m	6XV1 830-7BH15
For ET 200pro; for communication between ET 200pro and higher-level masters over PROFIBUS DP; support of PROFIsafe.		3.0 m	6XV1 830-7BH30
Accessories		5.0 m	6XV1 830-7BH50
CM IM DP ECOFAST connection module	6ES7 194-4AA00-0AA0	10 m	6XV1 830-7BN10
For connecting PROFIBUS DP and the 24 V power supply to PROFIBUS interface modules, 2 ECOFAST Cu connections.		15 m	6XV1 830-7BN15
CM IM DP direct connection module	6ES7 194-4AC00-0AA0	20 m	6XV1 830-7BN20
For connecting PROFIBUS DP and the 24 V power supply directly to PROFIBUS interface modules, up to six M20 cable glands.		25 m	6XV1 830-7BN25
CM IM DP M12, 7/8" connection module	6ES7 194-4AD00-0AA0	30 m	6XV1 830-7BN30
For connecting PROFIBUS DP and the 24 V power supply to PROFIBUS interface modules, 2 x M12 and 2 x 7/8".		35 m	6XV1 830-7BN35
		40 m	6XV1 830-7BN40
		45 m	6XV1 830-7BN45
		50 m	6XV1 830-7BN50

SIMATIC ET 200 distributed I/O

ET 200pro

Interface modules IM 154-1 and IM 154-2

Ordering data	Order No.	Order No.	
PROFIBUS ECOFAST hybrid cable GP, preassembled With 2 ECOFAST connectors, trailing-type cable with 2 x CU 0.64 mm ² and 4 x Cu 1.5 mm ² , in various lengths: 1.5 m 3.0 m 5.0 m 10 m 15 m 20 m 25 m 30 m 35 m 40 m 45 m 50 m	6XV1 860-3PH15 6XV1 860-3PH30 6XV1 860-3PH50 6XV1 860-3PN10 6XV1 860-3PN15 6XV1 860-3PN20 6XV1 860-3PN25 6XV1 860-3PN30 6XV1 860-3PN35 6XV1 860-3PN40 6XV1 860-3PN45 6XV1 860-3PN50	PROFIBUS FC Robust bus cable With PUR sheath for use in environments subject to harsh chemicals and extreme mechanical stress, 2-core, shielded, sold by the meter, minimum order quantity 20 m, maximum order quantity 1 000 m. Power line 5-core, 5 x 1.5 mm ² , trailing type, sold by the meter, minimum order quantity 20 m, maximum order quantity 1 000 m.	6XV1 830-0JH10 6XV1 830-8AH10
PROFIBUS ECOFAST hybrid cable, non-assembled Trailing-type cable with 2 x CU 0.64 mm ² and 4 x Cu 1.5 mm ² , in various lengths: 50 m 100 m	6XV1 830-7AN50 6XV1 830-7AT10	Accessories for CM IM DP M12, 7/8" PROFIBUS M12 connecting cable Preassembled with two M12 connectors, 5-pin, in various lengths: 1.5 m 2.0 m 3.0 m 5.0 m 10 m 15 m	6XV1 830-3DH15 6XV1 830-3DH20 6XV1 830-3DH30 6XV1 830-3DH50 6XV1 830-3DN10 6XV1 830-3DN15
PROFIBUS ECOFAST hybrid cable GP, non-assembled Trailing-type cable with 2 x CU 0.64 mm ² and 4 x Cu 1.5 mm ² , in various lengths: 50 m 100 m	6XV1 860-4PN50 6XV1 860-4PT10	7/8" connecting cable to power supply 5-core, 5 x 1.5 mm ² , trailing type, preassembled with two 7/8" connectors, 5-pin, in various lengths: 1.5 m 2.0 m 3.0 m 5.0 m 10 m 15 m	6XV1 822-5BH15 6XV1 822-5BH20 6XV1 822-5BH30 6XV1 822-5BH50 6XV1 822-5BN10 6XV1 822-5BN15
PROFIBUS ECOFAST hybrid connector 180 ECOFAST Cu, 2 x Cu, 4 x 1.5 mm ² , HANBRID connector • With male insert, 5-pack • With female insert, 5-pack	6GK1 905-0CA00 6GK1 905-0CB00	M12 cable connector For ET 200eco, with axial cable outlet. • With male insert, 5-pack • With female insert, 5-pack	6GK1 905-0EA00 6GK1 905-0EB00
PROFIBUS ECOFAST hybrid connector angular ECOFAST Cu, 2 x Cu, 4 x 1.5 mm ² , HANBRID connector • With male insert, 5-pack • With female insert, 5-pack	6GK1 905-0CC00 6GK1 905-0CD00	PROFIBUS M12 bus termination connector With male insert.	6GK1 905-0EC00
Accessories for CM IM DP direct PROFIBUS trailing cable Max. acceleration 4 m/s ² , at least 3 000 000 bending cycles, bending radius at least 60 mm, 2-core shielded, sold by the meter, minimum order quantity 20 m, maximum order quantity 1 000 m.	6XV1 830-3EH10	7/8" cable connector For ET 200eco, with axial cable outlet. • With male insert, 5-pack • With female insert, 5-pack	6GK1 905-0FA00 6GK1 905-0FB00
PROFIBUS FC Food bus cable With PE sheath for use in the food and beverages industry, 2-core, shielded, sold by the meter, minimum order quantity 20 m, maximum order quantity 1 000 m.	6XV1 830-0GH10	M12 sealing cap For protection of unused M12 connections with ET 200pro.	3RX9 802-0AA00
		Sealing cap 7/8" For protection of unused 7/8" connections with ET 200pro; 10 units per pack.	6ES7 194-3JA00-0AA0

Ordering data	Order No.	Order No.
General accessories		
ET 200pro rack		
<ul style="list-style-type: none"> Narrow, for interface, electronics and power modules <ul style="list-style-type: none"> 500 mm 1000 mm 2000 mm, can be cut to length Compact, for interface, electronics and power modules <ul style="list-style-type: none"> 500 mm 1000 mm 2000 mm, can be cut to length Wide, for interface, electronics, power modules and motor starters <ul style="list-style-type: none"> 500 mm 1000 mm 2000 mm, can be cut to length Wide, for I/O modules and motor starters <ul style="list-style-type: none"> 500 mm 1000 mm 2000 mm 	6ES7 194-4GA00-0AA0 6ES7 194-4GA60-0AA0 6ES7 194-4GA20-0AA0 6ES7 194-4GC70-0AA0 6ES7 194-4GC60-0AA0 6ES7 194-4GC20-0AA0 6ES7 194-4GB00-0AA0 6ES7 194-4GB60-0AA0 6ES7 194-4GB20-0AA0 6ES7 194-4GD00-0AA0 6ES7 194-4GD10-0AA0 6ES7 194-4GD20-0AA0	
Spare fuse	6ES7 194-4HB00-0AA0	
12.5 A fast-blow, for interface and power modules, 10 units per pack.		
PROFIBUS Fast Connect bus cable	6XV1 830-0EH10	
Standard type with special design for quick mounting, 2-core, shielded, sold by the meter, max. delivery unit 1 000 m, minimum order quantity 20 m.		
		PROFIBUS Hybrid Standard Cable GP
		Standard PROFIBUS hybrid cable with 2 energy cables (1.5 mm ²) for supplying data and energy for ET 200pro.
		6XV1 860-2R
		Technical product data
		For CAX applications, one-off license.
		6ES7 991-0CD01-0YX0
		SIMATIC Manual Collection
		Electronic manuals on DVD, multi-language: S7-200, TD 200, S7-300, M7-300, C7, S7-400, M7-400, STEP 7, Engineering Tools, Runtime Software, SIMATIC DP (Distributed I/O), SIMATIC HMI (Human Machine Interface), SIMATIC NET (Industrial Communication).
		6ES7 998-8XC01-8YE0
		SIMATIC Manual Collection – Update service for 1 year
		Scope of delivery: Current DVD "S7 Manual Collection" and the three subsequent updates.
		6ES7 998-8XC01-8YE2

SIMATIC ET 200 distributed I/O

ET 200pro

Interface modules IM 154-4 PN

Overview



Interface module for processing the communication between ET 200pro and a higher-level controller over PROFINET IO.

Technical specifications

6ES7 154-4AB10-0AB0	
General information	
Vendor identification (VendorID)	0x002A
Device identifier (DeviceID)	0x0305
Supply voltage	
Rated value (DC)	24 V
24 V DC	Yes
permissible range, lower limit (DC)	20.4 V; Unit [V]
permissible range, upper limit (DC)	28.8 V; Unit [V]
Reverse polarity protection	Yes; against destruction
Short-circuit protection	Yes; Fuse in lower part is exchangeable, the fuse on the IM-LP is not
Input current	
from supply voltage 1L+, max.	400 mA; Dependent on terminal module, typ. maximum value for FO connection method, full load on RWB and 20.4 V input voltage
from backplane bus 3.3 V DC, max.	Not applicable
Power losses	
Power loss, typ.	6 W; Dependent on terminal module, typ. maximum value for CU connection method, full load on RWB, for FO the value is approx. 0.7 W higher
Memory	
Micro Memory Card	No; Internal memory medium
Address area	
Addressing volume	
• Outputs	256 byte
• Inputs	256 byte

6ES7 154-4AB10-0AB0	
Interfaces	
Supports protocol for PROFINET IO	
• Automatic detection of transmission speed	Yes
• Transmission rate, max.	100 Mbit/s
• Services	ARP, PING, SNMP
Protocols	
Supports protocol for PROFINET IO	Yes
Interrupts/diagnostics/status information	
Diagnostics indication LED	
• Bus fault BF (red)	Yes; Additional LEDs (MAINT, P1/2 LINK, P1/2 RX/TX) available
• Group error SF (red)	Yes
• Monitoring 24 V voltage supply ON (green)	Yes
• Load voltage monitoring DC 24 V (green)	Yes
Parameter	
Diagnostic alarm	1
Hardware interrupt	1
Swapping interrupt	1
identifier-related diagnostic data	1
Module status	1
Channel-related diagnostics	1
Startup if setpoint not equal to actual configuration	1
Hot swapping of modules	1
Galvanic isolation	
between backplane bus and electronics	No
between supply voltage and electronics	Yes
Isolation	
Isolation checked with	500 V DC

Technical specifications (continued)

6ES7 154-4AB10-0AB0	
Degree and class of protection	
IP65	Yes
IP66	Yes
IP67	Yes
Ambient conditions	
Operating temperature	
• Min.	-25 °C
• max.	55 °C
Storage/transport temperature	
• Min.	-40 °C
• max.	70 °C

6ES7 154-4AB10-0AB0	
Dimensions	
Width	135 mm
Height	130 mm
Depth	59.3 mm
Weight	
Weight, approx.	490 g

Ordering data

Order No.	Order No.
IM 154-4 PN High Feature interface module For communication between ET 200pro and higher-level controllers over PROFINET IO; support of PROFI-safe.	6ES7 154-4AB10-0AB0
Accessories	
CM IM PN connection module M12, 7/8" For connecting PROFINET PN and 24 V power supply to PROFINET interface modules, 2 x M12 and 2 x 7/8".	6ES7 194-4AJ00-0AA0
CM IM PN connection module 2xRJ45 For connecting PROFINET PN and 24 V power supply to PROFINET interface modules, 2 x RJ45 and 2 x push-pull power connector.	6ES7 194-4AF00-0AA0
CM IM PN 2xSCRJ FO connection module For connecting PROFINET PN and 24 V power supply to PROFINET interface modules, 2 x SCRJ FO and 2 x push-pull power connector.	6ES7 194-4AG00-0AA0
M12 sealing cap For protection of unused M12 connections with ET 200pro.	3RX9 802-0AA00
IE M12 connecting cables Preassembled with two M12 connectors, up to 85 m, in various lengths: 0.3 m 0.5 m 1.0 m 1.5 m 2.0 m 3.0 m 5.0 m 10 m 15 m Other special lengths with 90° or 180° cable outlet.	6XV1 870-8AE30 6XV1 870-8AE50 6XV1 870-8AH10 6XV1 870-8AH15 6XV1 870-8AH20 6XV1 870-8AH30 6XV1 870-8AH50 6XV1 870-8AN10 6XV1 870-8AN15 See http://support.automation.siemens.com/WW/view/en/26999294

Order No.	Order No.
7/8" sealing caps 1 pack = 10 units	6ES7 194-3JA00-0AA0
7/8" connecting cable to power supply 5-core, 5 x 1.5 mm ² , trailing type, preassembled with two 7/8" connectors, 5-pin, up to 50 m, in various lengths: 1.5 m 2.0 m 3.0 m 5.0 m 10 m 15 m Other special lengths with 90° or 180° cable outlet.	6XV1 822-5BH15 6XV1 822-5BH20 6XV1 822-5BH30 6XV1 822-5BH50 6XV1 822-5BN10 6XV1 822-5BN15 siehe http://support.automation.siemens.com/WW/view/en/26999294
Power line 5-core, 5 x 1.5 mm ² , trailing type, sold by the meter, minimum order quantity 20 m, maximum order quantity 1 000 m.	6XV1 830-8AH10
7/8" cable connector For ET 200eco, with axial cable outlet. • With male insert, 5-pack • With female insert, 5-pack	6GK1 905-0FA00 6GK1 905-0FB00
Industrial Ethernet FastConnect installation cables	
• IE FC TP Standard Cable GP 2 x 2; Sold by the meter, max. delivery unit 1 000 m; minimum order quantity 20 m.	6XV1 840-2AH10
• IE FC TP Trailing Cable 2 x 2; Sold by the meter, max. delivery unit 1 000 m; minimum order quantity 20 m.	6XV1 840-3AH10
• IE FC TP Trailing Cable GP 2 x 2; Sold by the meter, max. delivery unit 1 000 m; minimum order quantity 20 m.	6XV1 870-2D
• IE TP Torsion Cable GP 2 x 2; Sold by the meter, max. delivery unit 1 000 m; minimum order quantity 20 m.	6XV1 870-2F
• IE FC TP Marine Cable 2 x 2; Sold by the meter, max. delivery unit 1 000 m; minimum order quantity 20 m.	6XV1 840-4AH10

SIMATIC ET 200 distributed I/O

ET 200pro

Interface modules
IM 154-4 PN

Ordering data	Order No.	Order No.
IE RJ45 Plug PRO RJ45 plug in IP65/67-rated design for on-site assembly, plastic housing, insulation/displacement connection system, for SCALANCE X-200IRT PRO and ET200pro: 1 pack = 1 unit.	6GK1901-1BB10-6AA0	General accessories ET 200pro rack <ul style="list-style-type: none"> Narrow, for interface, electronics and power modules <ul style="list-style-type: none"> - 500 mm - 1000 mm - 2000 mm, can be cut to length Compact, for interface, electronics and power modules <ul style="list-style-type: none"> - 500 mm - 1000 mm - 2000 mm, can be cut to length Wide, for interface, electronics, power modules and motor starters <ul style="list-style-type: none"> - 500 mm - 1000 mm - 2000 mm, can be cut to length Wide, for I/O modules and motor starters <ul style="list-style-type: none"> - 500 mm - 1000 mm - 2000 mm Spare fuse 12.5 A fast-blow, for interface and power modules, 10 units per pack.
IE SC RJ POF Plug PRO SC RJ plug for POF fibers in IP65/67-rated design for on-site assembly, plastic housing, for SCALANCE X-200IRT PRO and ET200pro 1 pack = 1 unit	6GK1900-0MB00-6AA0	
IE SC RJ PCF Plug PRO SC RJ plug connector for PCF fibers in IP65/67-rated design for on-site assembly, plastic housing, for SCALANCE X-200IRT PRO 1 pack = 1 unit.	6GK1900-0NB00-6AA0	
Power Plug PRO 5-pole power plug for 2 x 24 V power supply in IP65/67-rated design, for on-site assembly, plastic housing, for SCALANCE X-200IRT and ET200 pro 1 pack = 1 unit.	6GK1907-0AB10-6AA0	
IE panel feedthrough Control cabinet feedthrough for converting M12 D-coded connection system (IP65) to RJ45 connection system (IP20). <ul style="list-style-type: none"> 1 pack = 5 units 	6GK1 901-0DM20-2AA5	
Push-Pull cable connector For 1L+/ 2L+, unassembled	6GK1 907-0AB10-6AA0	
Cover caps for Push-Pull RJ45 female connectors 5 items per pack	6ES7 194-4JD50-0AA0	SIMATIC Manual Collection Electronic manuals on DVD, multi-language: S7-200, TD 200, S7-300, M7-300, C7, S7-400, M7-400, STEP 7, Engineering Tools, Runtime Software, SIMATIC DP (Distributed I/O), SIMATIC HMI (Human Machine Interface), SIMATIC NET (Industrial Communication).
		SIMATIC Manual Collection – Update service for 1 year Scope of delivery: Current DVD "S7 Manual Collection" and the three subsequent updates.

Overview



Interface module for handling communication between ET 200pro and host PROFINET IO controllers over Industrial Wireless LAN (IWLAN) radio networks for 2.4 GHz or 5 GHz with data transfer rates up to 54 Mbit/s.

- Protection against illegal access, espionage, tapping and falsification through use of effective encryption mechanisms
- Fast exchange of devices through use of interchangeable medium MICRO MEMORY CARD

Technical specifications

IM 154-6 PN IWLAN interface module	6ES7 154-6AB00-0AB0 6ES7 154-6AB50-0AB0
Supply voltage for electronic components 1L+	
• Rated value	24 V DC
• Valid range, lower limit	20.4 V DC
• Valid range, upper limit	28.8 V DC
• Short-circuit protection	Yes; replaceable fuse
• Reverse polarity protection	Yes; against destruction
• Max. infeed current	5 A
Load voltage 2L+	
• Rated value (DC)	24 V DC
• Lower limit of permissible range (DC)	20.4 V DC
• Upper limit of permissible range (DC)	28.8 V DC
• Short-circuit protection	Yes, for potential group
• Reverse polarity protection	Yes; against destruction
• Max. infeed current	8 A
Current consumption from supply voltage 1L+, typ.	335 mA
Power loss, typ.	8.5 W
Memory type	Micro Memory Card, is required
Address range/address volume	
• Outputs	256 byte
• Inputs	256 byte
Reports	
• PROFINET IO	Yes
• Industrial Wireless LAN	Yes
PROFINET IO services	ARP, PING, SNMP
Industrial Wireless LAN	
• Transmission rate, max.	54 Mbit/s
• Standards for wireless communication	IEEE 802.11a IEEE 802.11b IEEE 802.11g IEEE 802.11h (not valid for 6ES7 154-6AB50-0AB0) IEEE 802.11e IEEE 802.11i

IM 154-6 PN IWLAN interface module	6ES7 154-6AB00-0AB0 6ES7 154-6AB50-0AB0
• Radio frequency for WLAN in 2.4 GHz frequency band	2,4 ... 2.4835 GHz
• Radio frequency for WLAN in 5 GHz frequency band	5,15 ... 5.825 GHz
• Transmission method	Direct Sequence Spread Spectrum (DSSS) Complementary Code Keying (CCK) Orthogonal Frequency Division Multiplexing (OFDM)
• Supported IWLAN services	Current approvals can be found in the Internet at http://support.automation.siemens.com/WW/view/en/19812553
• Connection for external antenna	
Parameters	
• Diagnostic interrupt	Yes
• Maintenance alarm	Yes
• Hardware interrupt	Yes
• Swapping interrupt	Yes
• Identifier-related diagnostic data	Yes
• Module status	Yes
• Channel-specific diagnostics	Yes
• Start-up if preset configuration is not equal to actual configuration	Yes
• Module replacement during operation	Yes
Diagnostics indication (LED)	Yes
• Group fault (red)	Yes
• Bus fault (red)	Yes
• Maintenance information (yellow)	Yes
• Monitoring 24 V power supply ON (green)	Yes
• Load voltage monitoring 24 V DC (green)	Yes
• Connection to an Access Point R1 LINK (green)	Yes
• Data exchange R1 RX/TX (yellow)	Yes
• Connection to a PG/PC (green)	Yes
• Data exchange with a PG/PC (yellow)	Yes

SIMATIC ET 200 distributed I/O

ET 200pro

Interface modules
IM 154-6 PN IWLAN

Technical specifications (continued)

IM 154-6 PN IWLAN interface module	6ES7 154-6AB00-0AB0 6ES7 154-6AB50-0AB0	IM 154-6 PN IWLAN interface module	6ES7 154-6AB00-0AB0 6ES7 154-6AB50-0AB0
Insulation tested at	500 V DC	Degree of protection	IP65, IP66, IP67
Isolation		General information	
• Between the backplane bus and supply voltage 1L+ and 2L+	Yes	• Manufacturer's code (VendorID)	0x002A
• Between Ethernet and supply voltage 1L+ and 2L+	Yes	• Device ID	0x0305
• Between the supply voltage and electronic components	Yes	Dimensions	
Operating temperature		• Width	135 mm
• Minimum	-25 °C	• Height	130 mm
• Maximum	55 °C	• Depth	60 mm
Storage/transport temperature		Weight, approx.	1085 g
• Minimum	-40 °C		
• Maximum	70 °C		

Ordering data

Order No.	Order No.
IM 154-6 PN HF IWLAN interface module	Accessories
For communication between ET 200pro and higher-level controllers over Industrial Wireless LAN (IWLAN) radio networks; support of PROFIsafe.	7/8" connecting cable to power supply
With various national approvals; refer to the current list of approvals.	5-core, 5 x 1.5 mm ² , trailing type, preassembled with two 7/8" connectors, in various lengths:
With approval for USA.	1.5 m
Antennas with omnidirectional characteristic	2.0 m
Mounting directly on IM154-6 PN HF IWLAN	3.0 m
• ANT IM 154-6 IWLAN; 2 units	5.0 m
For wall or pipe mounting	10 m
• ANT 792-6MN; rod antenna N-Connect female 2.4 GHz; 1 unit	15 m
• ANT793-6MN; rod antenna N-Connect female 5 GHz; 1 unit	Other special lengths with 90° or 180° cable outlet.
For use with the RCoax antenna system	Power line
• ANT 792-4DN; RCoax N-Connect female 2.4 GHz; 1 unit	5-core, 5 x 1.5 mm ² , trailing type, sold by the meter, minimum order quantity 20 m, maximum order quantity 1 000 m.
• ANT793-4MN; RCoax N-Connect female 5 GHz; 1 unit	7/8" cable connector
Antenna cables IWLAN RCoax; N-Connect / R-SMA	For ET 200eco, with axial cable outlet; with socket insert, pack of 5.
1 m	Twisted Pair cables 4x2 with RJ45 connectors
2 m	0.5 m
5 m	1 m
10 m	2 m
IWLAN terminating resistor 50 ohms for second R-SMA antenna socket, 3 units.	6 m
	10 m

Ordering data	Order No.	Order No.
Crossed Twisted Pair cables 4x2 with RJ45 connectors 0.5 m 1 m 2 m 6 m 10 m	6XV1 870-3RE50 6XV1 870-3RH10 6XV1 870-3RH20 6XV1 870-3RH60 6XV1 870-3RN10	Spare fuse 12.5 A fast-blow, for interface and power modules, 10 units per pack. Labels 20 x 7 mm, pale turquoise, 340 units per pack. SIMATIC Micro Memory Card • 64 KB • 128 KB • 512 KB SIMATIC Manual Collection Electronic manuals on DVD, multi-language: S7-200, TD 200, S7-300, M7-300, C7, S7-400, M7-400, STEP 7, Engineering Tools, Runtime Software, SIMATIC DP (Distributed I/O), SIMATIC HMI (Human Machine Interface), SIMATIC NET (Industrial Communication). SIMATIC Manual Collection – Update service for 1 year Scope of delivery: Current DVD "S7 Manual Collection" and the three subsequent updates.
IE FC RJ45 Plug 180 180° cable outlet; for line components and CPs/CPU with Industrial Ethernet interface. • 1 pack = 1 unit • 1 pack = 10 units	6GK1 901-1BB10-2AA0 6GK1 901-1BB10-2AB0	6ES7 194-4HB00-0AA0 3RT1 900-1SB20 6ES7 953-8LF20-0AA0 6ES7 953-8LG20-0AA0 6ES7 953-8LJ30-0AA0 6ES7 998-8XC01-8YE0
IE FC RJ45 Plug 90 90° cable outlet; e.g. for ET 200S. • 1 pack = 1 unit • 1 pack = 10 units	6GK1 901-1BB20-2AA0 6GK1 901-1BB20-2AB0	6ES7 998-8XC01-8YE2
General accessories ET 200pro rack • Narrow, for interface, electronics and power modules - 500 mm - 1000 mm - 2000 mm, can be cut to length • Compact, for interface, electronics and power modules - 500 mm - 1000 mm - 2000 mm, can be cut to length • Wide, for interface, electronics, power modules and motor starters - 500 mm - 1000 mm - 2000 mm, can be cut to length • Wide, for I/O modules and motor starters - 500 mm - 1000 mm - 2000 mm	6ES7 194-4GA00-0AA0 6ES7 194-4GA60-0AA0 6ES7 194-4GA20-0AA0 6ES7 194-4GC70-0AA0 6ES7 194-4GC60-0AA0 6ES7 194-4GC20-0AA0 6ES7 194-4GB00-0AA0 6ES7 194-4GB60-0AA0 6ES7 194-4GB20-0AA0 6ES7 194-4GD00-0AA0 6ES7 194-4GD10-0AA0 6ES7 194-4GD20-0AA0	

SIMATIC ET 200 distributed I/O

ET 200pro

Interface modules IM 154-8 PN/DP CPU

Overview



- CPU with PLC functionality equivalent to S7-315-2 PN/DP provides distributed intelligence for preprocessing
 - Interface module for exchanging pre-processed I/O data between the ET 200pro and a higher-level master/IO Controller via PROFIBUS DP/PROFINET IO
 - PROFINET IO Controller to operate distributed I/Os on PROFINET
 - Component based Automation (CBA) on PROFINET
 - PROFINET proxy for intelligent devices on PROFIBUS DP in Component Based Automation (CBA)
 - PROFINET interface with 3-port switch
 - Isochronous mode on PROFIBUS or PROFINET
 - Integrated web server with the option of creating user-defined web pages
 - CPU with PLC functionality equivalent to S7-315-2 PN/DP provides distributed intelligence for preprocessing
 - Interface module to exchange preprocessed I/O data from ET 200pro with a higher-level master through PROFIBUS DP
 - Fast, simple and end-to-end programming of a system with modular programs via STEP 7
 - Fail-safe IM 154-8F PN/DP CPU PROFIsafe available
- Micro Memory Card required for operation of CPU.

Technical specifications

6ES7 154-8AB01-0AB0	
General information	
Engineering with	
• Programming package	STEP7 V 5.5 or higher
Supply voltage	
24 V DC	Yes
Power losses	
Power loss, typ.	8.5 W; Typical
Memory	
Work memory	
• integrated	384 kbyte
Load memory	
• pluggable (MMC), max.	8 Mbyte
CPU processing times	
for bit operations, typ.	0.05 μ s
for word operations, typ.	0.09 μ s
for fixed point arithmetic, typ.	0.12 μ s
for floating point arithmetic, typ.	0.45 μ s
Counters, timers and their retentivity	
S7 counter	
• Number	256
IEC counter	
• present	Yes
S7 times	
• Number	256
IEC timer	
• present	Yes
Data areas and their retentivity	
Flag	
• Number, max.	2 048 byte

6ES7 154-8AB01-0AB0	
Address area	
I/O address area	
• Inputs	2 048 byte
• Outputs	2 048 byte
Process image	
• Inputs, adjustable	2 048 byte
• Outputs, adjustable	2 048 byte
Time of day	
Clock	
• Hardware clock (real-time clock)	Yes
Operating hours counter	
• Number	1
1st interface	
Type of interface	Integrated RS 485 interface
Physics	RS 485/connection: 2 x M12 b-coded
Functionality	
• MPI	Yes
• DP master	Yes
• DP slave	Yes
• Point-to-point connection	No
DP master	
• Number of DP slaves, max.	124
2nd interface	
Type of interface	PROFINET
Physics	Ethernet (2 x M12 d-coded; 1 x RJ45)
Number of ports	3

Technical specifications (continued)

6ES7 154-8AB01-0AB0	
Functionality	
• MPI	No
• DP master	No
• DP slave	No
• PROFINET IO Controller	Yes; Also simultaneously with IO-Device functionality
• PROFINET IO Device	Yes; Also simultaneously with IO Controller functionality
• PROFINET CBA	Yes
PROFINET IO Controller	
• Max. number of connectable IO devices for RT	128
• Number of IO devices with IRT and the option "high flexibility"	128
• Number of IO Devices with IRT and the option "high performance", max.	64
Isochronous mode	
Isochronous operation (application synchronized up to terminal)	Yes; Via PROFIBUS DP or PROFINET interface
Communication functions	
PG/OP communication	Yes
Global data communication	
• supported	Yes
S7 basic communication	
• supported	Yes
S7 communication	
• supported	Yes
Open IE communication	
• TCP/IP	Yes; via integrated PROFINET interface and loadable FBs
- Number of connections, max.	8
• ISO-on-TCP (RFC1006)	Yes
- Number of connections, max.	8
• UDP	Yes
- Number of connections, max.	8
Web server	
• supported	Yes

6ES7 154-8AB01-0AB0	
Configuration	
programming	
• Programming language	
- LAD	Yes
- FBD	Yes
- STL	Yes
- SCL	Yes
- CFC	Yes
- GRAPH	Yes
- HiGraph®	Yes
Know-how protection	
• User program protection/password protection	Yes
• Block encryption	Yes; With S7 block Privacy
Dimensions	
Width	135 mm
Height	130 mm
Depth	65 mm; 60 mm without cover for RJ45 socket; 65 mm with cover for RJ45 socket
Weight	
Weight, approx.	720 g

Ordering data

Order No.	Order No.
IM 154-8 PN/DP CPU interface module, V3.2	6ES7 154-8AB01-0AB0
PROFINET IO Controller for operating distributed I/Os on PROFINET, with integrated PLC functionality.	
Accessories	
MMC 64 KB ¹⁾	6ES7 953-8LF20-0AA0
For program backup.	
MMC 128 KB ¹⁾	6ES7 953-8LG20-0AA0
For program backup.	
MMC 512 KB ¹⁾	6ES7 953-8LJ30-0AA0
For program backup.	
MMC 2 MB ¹⁾	6ES7 953-8LL31-0AA0
For program backup and/or firmware updates.	
MMC 4 MB ¹⁾	6ES7 953-8LM20-0AA0
For program backup.	
MMC 8 MB ¹⁾	6ES7 953-8LP20-0AA0
For program backup.	

¹⁾ An MMC is essential for operating the CPU

Order No.	Order No.
Connection module	6ES7 194-4AN00-0AA0
For CPU IM154-8 PN/DP, with 4 x M12 and 2 x 7/8", for connecting PROFINET and PROFIBUS DP.	
SCALANCE X-200 Industrial Ethernet Switches	6GK5 208-0HA00-2AA6
With integral SNMP access, Web diagnostics, copper cable diagnostics and PROFINET diagnostics, for setting up linear, star and ring structures SCALANCE X208PRO, in degree of protection IP65, with eight 10/100 Mbit/s M12 ports, incl. eleven M12 dust caps.	
Industrial Ethernet FC RJ45 Plug 180	
RJ45 plug connector for Industrial Ethernet with a rugged metal enclosure and integrated insulation displacement contacts for connecting Industrial Ethernet FC installation cables; with 180° cable outlet	
• 1 unit	6GK1 901-1BB10-2AA0
• 10 units	6GK1 901-1BB10-2AB0
• 50 units	6GK1 901-1BB10-2AE0

SIMATIC ET 200 distributed I/O

ET 200pro

Interface modules
IM 154-8 PN/DP CPU

Ordering data

Order No.

Order No.

Industrial Ethernet Fast Connect installation cables

- FastConnect Standard Cable
- FastConnect Trailing Cable
- FastConnect Marine Cable

6XV1 840-2AH10
6XV1 840-3AH10
6XV1 840-4AH10

Industrial Ethernet FastConnect installation cables

- **IE FC TP Trailing Cable GP 2 x 2;** sold by the meter, max. delivery unit 1 000 m; minimum order quantity 20 m.
- **IE TP Torsion Cable GP 2 x 2;** sold by the meter, max. delivery unit 1 000 m; minimum order quantity 20 m.

6XV1 870-2D

6XV1 870-2F

Industrial Ethernet Fast Connect

Stripping Tool

6GK1 901-1GA00

IE Connecting Cable M12-180/M12-180

- Preassembled IE FC TP Trailing Cable GP 2 x 2 (PROFINET Type C) with two 4-pin M12 plugs (4-pin, D-coded), degree of protection IP65/IP67, in various lengths:
 - 0.3 m
 - 0.5 m
 - 1.0 m
 - 1.5 m
 - 2.0 m
 - 3.0 m
 - 5.0 m
 - 10 m
 - 15 m
- PROFINET M12 connecting cable, trailing cable preassembled at both ends with angled M12 connectors (male insert), in various lengths:
 - 3.0 m
 - 5.0 m
 - 10 m
- PROFINET M12 connecting cable, trailing cable preassembled at one end with angled M12 connector (male insert at one end, other end open), in various lengths:
 - 3.0 m
 - 5.0 m
 - 10 m

6XV1 870-8AE30
6XV1 870-8AE50
6XV1 870-8AH10
6XV1 870-8AH15
6XV1 870-8AH20
6XV1 870-8AH30
6XV1 870-8AH50
6XV1 870-8AN10
6XV1 870-8AN15

3RK1 902-2NB30
3RK1 902-2NB50
3RK1 902-2NC10

3RK1 902-2HB30
3RK1 902-2HB50
3RK1 902-2HC10

IE FC M12 Plug PRO

PROFINET M12 plug connector, D-coded with fast connection system, axial cable outlet.

- 1 unit
- 8 units
- PROFINET M12 plug connector, D-coded, angled.

6GK1 901-0DB20-6AA0
6GK1 901-0DB20-6AA8
3RK1 902-2DA00

IE panel feedthrough

Cabinet feedthrough for converting from the M12 connection system (D-coded, IP65/IP67) to the RJ45 connection system (IP20), 1 pack = 5 units.

6GK1 901-0DM20-2AA5

7/8" connecting cable to power supply5-core, 5 x 1.5 mm², trailing type, preassembled with two 7/8" connectors (axial cable outlet), 5-pin, up to 50 m, in various lengths:

- 1.5 m
- 2.0 m
- 3.0 m
- 5.0 m
- 10 m
- 15 m
- Other special lengths with 90° or 180° cable outlet.

6XV1 822-5BH15
6XV1 822-5BH20
6XV1 822-5BH30
6XV1 822-5BH50
6XV1 822-5BN10
6XV1 822-5BN15

See
<http://support.automation.siemens.com/WWW/view/en/26999294>

- Power cable, can be trailed, 5 x 1.5 mm², preassembled at both ends with 7/8" angled connectors (female insert at one end, male insert at the other end), in various lengths:

- 3.0 m
- 5.0 m
- 10 m

3RK1 902-3NB30
3RK1 902-3NB50
3RK1 902-3NC10

- Power cable, can be trailed, 5 x 1.5 mm², preassembled at one end with 7/8" angled connector with female insert (female insert at one end, other end open), in various lengths:

- 3.0 m
- 5.0 m
- 10 m

3RK1 902-3GB30
3RK1 902-3GB50
3RK1 902-3GC10

Power line5-core, 5 x 1.5 mm², trailing type, sold by the meter, minimum order quantity 20 m, maximum order quantity 1 000 m.

6XV1 830-8AH10

7/8" cable connector

For ET 200eco, with axial cable outlet.

- with male insert, 5-pack
- with female insert, 5-pack
- angled, with female insert, 1 unit
- angled, with male insert, 1 unit

6GK1 905-0FA00
6GK1 905-0FB00
3RK1 902-3DA00
3RK1 902-3BA00

7/8" cover cap, 10 per pack

6ES7 194-3JA00-0AA0

Twisted Pair cables 4x2 with RJ45 connectors

0.5 m
1 m
2 m
6 m
10 m

6XV1 870-3QE50
6XV1 870-3QH10
6XV1 870-3QH20
6XV1 870-3QH60
6XV1 870-3QN10

Crossed Twisted Pair cables 4x2 with RJ45 connectors

0.5 m
1 m
2 m
6 m
10 m

6XV1 870-3RE50
6XV1 870-3RH10
6XV1 870-3RH20
6XV1 870-3RH60
6XV1 870-3RN10

Ordering data	Order No.	Order No.
M12 sealing cap For protection of unused M12 connections with ET 200pro	3RX9 802-0AA00	PROFIBUS FC Standard Cable GP Standard type with special design for fast mounting, 2-core, shielded. Sold by the meter; max. delivery unit 1 000 m, minimum order quantity 20 m.
M12 sealing caps with female thread 5 units	6ES7 194-4JD60-0AA0	PROFIBUS FC Trailing Cable 2-wire, shielded.
PROFIBUS M12 connecting cable Preassembled, with two 5-pole M12 connectors/sockets, up to 100 m, in various lengths: 1.5 m 2.0 m 3.0 m 5.0 m 10 m 15 m Other special lengths with 90° or 180° cable outlet	6XV1 830-3DH15 6XV1 830-3DH20 6XV1 830-3DH30 6XV1 830-3DH50 6XV1 830-3DN10 6XV1 830-3DN15 See http://support.automation.siemens.com/WW/view/en/26999294	PROFIBUS FC Food Cable 2-wire, shielded. Sold by the meter; max. delivery unit 1 000 m, minimum order quantity 20 m.
M12 bus termination connector for PROFIBUS, female insert	6GK1 905-0ED00	PROFIBUS FC Robust Cable 2-core, shielded Sold by the meter; max. delivery unit 1 000 m, minimum order quantity 20 m.
M12 bus termination connector for PROFIBUS, male insert	6GK1 905-0EC00	PROFIBUS M12 cable connector 5-pole, B-coded, metal casing, 1 pack = 5 units. • Female insert
M12 plug connector, axial outlet, with male insert	6GK1 905-0EA00	6XV1 830-0EH10 6XV1 830-3EH10 6XV1 830-0GH10 6XV1 830-0JH10 6GK1 905-0EB00

SIMATIC ET 200 distributed I/O

ET 200pro

Interface modules IM 154-8 F PN/DP CPU

Overview



- Interface module for SIMATIC ET 200pro with integrated fail-safe CPU
- CPU with PLC functionality equivalent to CPU S7-315F PN/DP; with distributed intelligence for preprocessing
- For constructing a fail-safe automation system for plants with increased safety requirements
- Complies with safety requirements up to SIL 3 according to IEC 61508, IEC 62061, up to PLe according to ISO 13849-1:2006 and Cat. 4 according to EN 954-1
- For high-performance control solutions in ET 200pro
- Increase of the availability of systems and machines
- Integral Web server with the option of creating user-defined Web sites
- Isochronous mode on PROFIBUS or PROFINET
- PROFINET IO Controller for up to 128 IO Devices
- PROFINET interface with integrated 3-port switch
- With many communication options:
PG/OP communication, PROFINET IO, PROFINET CBA, open IE communication (TCP, ISO-on-TCP and UDP), web server and S7-communication (with loadable FBs)
- Fast, simple and end-to-end programming of a system with modular programs via STEP 7
- Compact SIMATIC Micro Memory Card (MMC)

Note:

SIMATIC Micro Memory Card required for operation of CPU.

Technical specifications

	6ES7 154-8FB01-0AB0	6ES7 154-8FX00-0AB0
General information		
Engineering with • Programming package	STEP 7 V 5.5 or higher, Distributed Safety V 5.4 SP4	As of STEP7 V5.5 with HSP 222 + Distributed Safety V5.4 SP4
Supply voltage 24 V DC	Yes	Yes
Power losses Power loss, typ.	8.5 W; Typical	8.5 W; Typical
Memory		
Work memory • integrated	512 kbyte	1 536 kbyte
Load memory • pluggable (MMC), max.	8 Mbyte	8 Mbyte
CPU processing times		
for bit operations, typ.	0.05 µs	0.025 µs
for word operations, typ.	0.09 µs	0.03 µs
for fixed point arithmetic, typ.	0.12 µs	0.04 µs
for floating point arithmetic, typ.	0.45 µs	0.16 µs
Counters, timers and their retentivity		
S7 counter • Number	256	256
IEC counter • present	Yes	Yes
S7 times • Number	256	256
IEC timer • present	Yes	Yes
Data areas and their retentivity		
Flag • Number, max.	2 048 byte	2 048 byte

Technical specifications (continued)

	6ES7 154-8FB01-0AB0	6ES7 154-8FX00-0AB0
Address area		
I/O address area		
• Inputs	2 048 byte	2 048 byte
• Outputs	2 048 byte	2 048 byte
Process image		
• Inputs, adjustable	2 048 byte	2 048 byte
• Outputs, adjustable	2 048 byte	2 048 byte
Time of day		
Clock		
• Hardware clock (real-time clock)	Yes	Yes
Operating hours counter		
• Number	1	1
1st interface		
Type of interface	Integrated RS 485 interface	Integrated RS 485 interface
Physics	RS 485/connection: 2 x M12 b-coded	RS 485/connection: 2 x M12 b-coded
Functionality		
• MPI	Yes	Yes
• DP master	Yes	Yes
• DP slave	Yes	Yes
• Point-to-point connection	No	No
DP master		
• Number of DP slaves, max.	124	124
2nd interface		
Type of interface	PROFINET	PROFINET
Physics	Ethernet (2 x M12 d-coded; 1 x RJ45)	Ethernet (2 x M12 d-coded; 1 x RJ45)
Number of ports	3	3
Functionality		
• MPI	No	No
• DP master	No	No
• DP slave	No	No
• PROFINET IO Controller	Yes; Also simultaneously with IO-Device functionality	Yes; Also simultaneously with IO-Device functionality
• PROFINET IO Device	Yes; Also simultaneously with IO Controller functionality	Yes; Also simultaneously with IO Controller functionality
• PROFINET CBA	Yes	Yes
PROFINET IO Controller		
• Max. number of connectable IO devices for RT	128	128
• Number of IO devices with IRT and the option "high flexibility"	128	128
• Number of IO Devices with IRT and the option "high performance", max.	64	64
Isochronous mode		
Isochronous operation (application synchronized up to terminal)	Yes; Via PROFIBUS DP or PROFINET interface	Yes; Via PROFIBUS DP or PROFINET interface
Communication functions		
PG/OP communication	Yes	Yes
Global data communication		
• supported	Yes	Yes
S7 basic communication		
• supported	Yes	Yes
S7 communication		
• supported	Yes	Yes
Open IE communication		
• TCP/IP	Yes; via integrated PROFINET interface and loadable FBs	Yes; via integrated PROFINET interface and loadable FBs
- Number of connections, max.	8	8
• ISO-on-TCP (RFC1006)	Yes	Yes
- Number of connections, max.	8	8
• UDP	Yes	Yes
- Number of connections, max.	8	8
Web server		
• supported	Yes	Yes

SIMATIC ET 200 distributed I/O

ET 200pro

Interface modules IM 154-8 F PN/DP CPU

Technical specifications (continued)

	6ES7 154-8FB01-0AB0	6ES7 154-8FX00-0AB0
Configuration		
programming		
• Programming language		
- LAD	Yes	Yes
- FBD	Yes	Yes
- STL	Yes	Yes
- SCL	Yes	Yes
- CFC	Yes	Yes
- GRAPH	Yes	Yes
- HiGraph®	Yes	Yes
Know-how protection		
• User program protection/password protection	Yes	Yes
• Block encryption	Yes; With S7 block Privacy	Yes; With S7 block Privacy
Dimensions		
Width	135 mm	135 mm
Height	130 mm	130 mm
Depth	65 mm; 60 mm without cover for RJ45 socket; 65 mm with cover for RJ45 socket	65 mm; 60 mm without cover for RJ45 socket; 65 mm with cover for RJ45 socket
Weight		
Weight, approx.	720 g	720 g

Ordering data

IM 154-8 F PN/DP CPU interface module, V3.2

Fail-safe PROFINET IO Controller for operating distributed I/Os on PROFINET, with integrated PLC functionality.

- 512 KB RAM
- 1.5 MB RAM

Order No.

6ES7 154-8FB01-0AB0
6ES7 154-8FX00-0AB0

Distributed Safety V5.4 programming tool

Task:

Engineering tool for configuring fail-safe user programs for SIMATIC S7-300F, S7-400F, WinAC RTX F, ET 200S, ET 200M, ET 200iSP, ET 200pro, ET 200eco

Requirement:

STEP 7 V5.3 SP3 and higher

Floating license

6ES7 833-1FC02-0YA5

Distributed Safety Upgrade

From V5.x to V5.4; Floating license for 1 user

6ES7 833-1FC02-0YE5

STEP 7 Safety Advanced V11

Task:

Engineering tool for configuring fail-safe user programs for SIMATIC S7-300F, S7-400F, WinAC RTX F, ET 200S, ET 200M, ET 200iSP, ET 200pro, ET 200eco

Requirement:

STEP 7 Professional V11 SP1

Floating license for 1 user

6ES7 833-1FA11-0YA5

STEP 7 Safety Advanced Upgrade

Distributed Safety V5.4 SP5 and STEP 7 Safety Advanced V11 for parallel use; incl. software on CD; Combo License for 1 user

6ES7 833-1FA11-0YE5

Order No.

Accessories

MMC 64 KB ¹⁾

For program backup.

6ES7 953-8LF20-0AA0

MMC 128 KB ¹⁾

For program backup.

6ES7 953-8LG20-0AA0

MMC 512 KB ¹⁾

For program backup.

6ES7 953-8LJ30-0AA0

MMC 2 MB ¹⁾

For program backup and/or firmware updates.

6ES7 953-8LL31-0AA0

MMC 4 MB ¹⁾

For program backup.

6ES7 953-8LM20-0AA0

MMC 8 MB ¹⁾

For program backup.

6ES7 953-8LP20-0AA0

Connection module

For CPU IM154-8 PN/DP, with 4 x M12 and 2 x 7/8", for connecting PROFINET and PROFIBUS DP.

6ES7 194-4AN00-0AA0

SCALANCE X-200 Industrial Ethernet Switches

With integral SNMP access, Web diagnostics, copper cable diagnostics and PROFINET diagnostics, for setting up linear, star and ring structures SCALANCE X208PRO, in degree of protection IP65, with eight 10/100 Mbit/s M12 ports, incl. eleven M12 dust caps.

6GK5 208-0HA00-2AA6

¹⁾ An MMC is essential for operating the CPU

Ordering data	Order No.	Order No.
Industrial Ethernet FC RJ45 Plug 90 RJ45 plug-in connector for Industrial Ethernet with a rugged metal housing and integrated insulation displacement contacts for connecting Industrial Ethernet FC installation cables; with 90° cable outlet. <ul style="list-style-type: none"> • 1 unit • 10 units 	6GK1 901-1BB20-2AA0 6GK1 901-1BB20-2AB0	IE FC M12 Plug PRO PROFINET M12 plug connector, D-coded with fast connection system, axial cable outlet. <ul style="list-style-type: none"> • 1 unit • 8 units • PROFINET M12 plug connector, D-coded, angled
Industrial Ethernet FC RJ45 Plug 180 RJ45 plug connector for Industrial Ethernet with a rugged metal enclosure and integrated insulation displacement contacts for connecting Industrial Ethernet FC installation cables; with 180° cable outlet <ul style="list-style-type: none"> • 1 unit • 10 units • 50 units 	6GK1 901-1BB10-2AA0 6GK1 901-1BB10-2AB0 6GK1 901-1BB10-2AE0	IE panel feedthrough Cabinet feedthrough for converting from the M12 connection system (D-coded, IP65/IP67) to the RJ45 connection system (IP20), 1 pack = 5 units
Industrial Ethernet FastConnect installation cables <ul style="list-style-type: none"> • FastConnect Standard Cable • FastConnect Trailing Cable • FastConnect Marine Cable 	6XV1 840-2AH10 6XV1 840-3AH10 6XV1 840-4AH10	7/8" connecting cable to power supply <ul style="list-style-type: none"> • 5-core, 5 x 1.5 mm², trailing type, preassembled with two 7/8" connectors (axial cable outlet), 5-pin, up to 50 m, in various lengths: <ul style="list-style-type: none"> - 1.5 m - 2.0 m - 3.0 m - 5.0 m - 10 m - 15 m - Other special lengths with 90° or 180° cable outlet
Industrial Ethernet FastConnect installation cables <ul style="list-style-type: none"> • IE FC TP Trailing Cable GP 2 x 2; sold by the meter, max. delivery unit 1 000 m; minimum order quantity 20 m. • IE TP Torsion Cable GP 2 x 2; sold by the meter, max. delivery unit 1 000 m; minimum order quantity 20 m. 	6XV1 870-2D 6XV1 870-2F	<ul style="list-style-type: none"> • Power cable, can be trailed, 5 x 1.5 mm², preassembled at both ends with 7/8" angled connectors (female insert at one end, male insert at the other end), in various lengths: <ul style="list-style-type: none"> - 3.0 m - 5.0 m - 10 m
Industrial Ethernet FastConnect Stripping Tool	6GK1 901-1GA00	<ul style="list-style-type: none"> • Power cable, can be trailed, 5 x 1.5 mm², preassembled at one end with 7/8" angled connector with female insert (female insert at one end, other end open), in various lengths: <ul style="list-style-type: none"> - 3.0 m - 5.0 m - 10 m
IE Connecting Cable M12-180/M12-180 <ul style="list-style-type: none"> • Preassembled IE FC TP Trailing Cable GP 2 x 2 (PROFINET Type C) with two 4-pin M12 plugs (4-pin, D-coded), degree of protection IP65/IP67, in various lengths: <ul style="list-style-type: none"> - 0.3 m - 0.5 m - 1.0 m - 1.5 m - 2.0 m - 3.0 m - 5.0 m - 10 m - 15 m • PROFINET M12 connecting cable, trailing cable preassembled at both ends with angled M12 connectors (male insert), in various lengths: <ul style="list-style-type: none"> - 3.0 m - 5.0 m - 10 m • PROFINET M12 connecting cable, trailing cable preassembled at one end with angled M12 connector (male insert at one end, other end open), in various lengths: <ul style="list-style-type: none"> - 3.0 m - 5.0 m - 10 m 	6XV1 870-8AE30 6XV1 870-8AE50 6XV1 870-8AH10 6XV1 870-8AH15 6XV1 870-8AH20 6XV1 870-8AH30 6XV1 870-8AH50 6XV1 870-8AN10 6XV1 870-8AN15 3RK1 902-2NB30 3RK1 902-2NB50 3RK1 902-2NC10 3RK1 902-2HB30 3RK1 902-2HB50 3RK1 902-2HC10	Power line 5-core, 5 x 1.5 mm ² , trailing type, sold by the meter, minimum order quantity 20 m, maximum order quantity 1 000 m.
		7/8" cable connector For ET 200eco, with axial cable outlet <ul style="list-style-type: none"> • with male insert, 5-pack • with female insert, 5-pack • angled, with female insert, 1 unit • angled, with male insert, 1 unit 7/8" cover cap, 10 per pack
		Twisted Pair cables 4x2 with RJ45 connectors <ul style="list-style-type: none"> 0.5 m 1 m 2 m 6 m 10 m
		6GK1 901-0DB20-6AA0 6GK1 901-0DB20-6AA8 3RK1 902-2DA00 6GK1 901-0DM20-2AA5 6XV1 822-5BH15 6XV1 822-5BH20 6XV1 822-5BH30 6XV1 822-5BH50 6XV1 822-5BN10 6XV1 822-5BN15 See http://support.automation.siemens.com/WWW/view/en/26999294 3RK1 902-3NB30 3RK1 902-3NB50 3RK1 902-3NC10 3RK1 902-3GB30 3RK1 902-3GB50 3RK1 902-3GC10 6XV1 830-8AH10

SIMATIC ET 200 distributed I/O

ET 200pro

Interface modules
IM 154-8 F PN/DP CPU

Ordering data	Order No.	Order No.
Crossed Twisted Pair cables 4x2 with RJ45 connectors		M12 bus termination connector for PROFIBUS, female insert
0.5 m	6XV1 870-3RE50	6GK1 905-0ED00
1 m	6XV1 870-3RH10	M12 bus termination connector for PROFIBUS, male insert
2 m	6XV1 870-3RH20	6GK1 905-0EC00
6 m	6XV1 870-3RH60	M12 plug connector, axial outlet, with male insert
10 m	6XV1 870-3RN10	6GK1 905-0EA00
M12 sealing cap	3RX9 802-0AA00	PROFIBUS FC Standard Cable GP
For protection of unused M12 connections with ET 200pro		Standard type with special design for fast mounting, 2-core, shielded.
M12 sealing caps with female thread	6ES7 194-4JD60-0AA0	Sold by the meter; max. delivery unit 1 000 m, minimum order quantity 20 m.
5 units		PROFIBUS FC Trailing Cable
PROFIBUS M12 connecting cable		2-wire, shielded.
Preassembled, with two 5-pole M12 connectors/sockets, up to 100 m, in various lengths:		PROFIBUS FC Food Cable
1.5 m	6XV1 830-3DH15	2-wire, shielded.
2.0 m	6XV1 830-3DH20	Sold by the meter; max. delivery unit 1 000 m, minimum order quantity 20 m.
3.0 m	6XV1 830-3DH30	PROFIBUS FC Robust Cable
5.0 m	6XV1 830-3DH50	2-wire, shielded.
10 m	6XV1 830-3DN10	Sold by the meter; max. delivery unit 1 000 m, minimum order quantity 20 m.
15 m	6XV1 830-3DN15	PROFIBUS M12 cable connector
Additional special lengths with 90° or 180° cable outlet.	See http://support.automation.siemens.com/WW/view/en/26999294	5-pole, B-coded, metal casing, 1 pack = 5 units. • Female insert
		6GK1 905-0EB00

Overview



- Expansion modules with digital inputs/outputs for connection of actuators/sensors
- With scalable diagnostics
 - Standard modules with module-specific diagnostics
 - High-feature module with channel-specific diagnostics and parameterizable input delay or hardware interrupts
- Double or single assignment can be implemented for each M12 in the case of the 8DI and 8DO module by selecting CM IO 4 x M12 or CM IO 8 x M12
- IO connection modules are available in metal and plastic versions

Technical specifications

	6ES7 141-4BF00-0AA0	6ES7 141-4BF00-0AB0	6ES7 141-4BH00-0AA0
FH technology			
Module for failsafe applications	No	No	
Supply voltage			
24 V DC	Yes	Yes	Yes
permissible range, lower limit (DC)	20.4 V	20.4 V	20.4 V
permissible range, upper limit (DC)	28.8 V	28.8 V	28.8 V
Reverse polarity protection	Yes; Against destruction; encoder power supply outputs applied with reversed polarity	Yes; against destruction; load increasing	Yes; Against destruction; encoder power supply outputs applied with reversed polarity
Input current			
from supply voltage 1L+, max.	20 mA	20 mA	30 mA
from backplane bus 3.3 V DC, max.	20 mA	40 mA	20 mA
Encoder supply			
Number of outputs	8	8	8
Output current			
• up to 55 °C, max.	1 A	1 A	1 A
Power losses			
Power loss, typ.	2.5 W	2.5 W	3 W
Address area			
Occupied address area			
• Inputs	1 byte	1 byte	2 byte
Digital inputs			
Number/binary inputs	8	8	16
Input characteristic curve acc. to IEC 61131, Type 1	Yes	No	Yes
Input characteristic curve acc. to IEC 61131, Type 2	No	Yes	
Number of simultaneously controllable inputs			
• all mounting positions			
- up to 55 °C, max.	8	8	16
Input voltage			
• Type of input voltage	DC	DC	
• Rated value, DC	24 V	24 V	24 V
• for signal "0"	-3 to +5 V	-3 to +5 V	-3 to +5 V
• for signal "1"	13 to 30 V	11 to 30 V	11 to 30 V
Input current			
• for signal "1", typ.	7 mA	7 mA	4 mA

SIMATIC ET 200 distributed I/O

ET 200pro

I/O modules
Digital expansion modules

Technical specifications (continued)

	6ES7 141-4BF00-0AA0	6ES7 141-4BF00-0AB0	6ES7 141-4BH00-0AA0
Input delay (for rated value of input voltage)			
• for standard inputs			
- Parameterizable	No	Yes	No
- at "0" to "1", min.	1.2 ms	0.5 ms; 0.5 ms/ 3ms/ 15 ms/ 20 ms	1.2 ms
- at "0" to "1", max.	4.8 ms	20 ms	4.8 ms
- at "1" to "0", min.	1.2 ms	0.5 ms; 0.5 ms/ 3ms/ 15 ms/ 20 ms	0.7 ms
- at "1" to "0", max.	4.8 ms	20 ms	3 ms
Cable length			
• Cable length, shielded, max.	30 m	30 m	30 m
• Cable length unshielded, max.	30 m	30 m	30 m
Encoder			
Connectable encoders			
• 2-wire sensor	Yes	Yes	Yes
- Permissible quiescent current (2-wire sensor), max.	1.5 mA	1.5 mA	1.5 mA
Isochronous mode			
Isochronous operation (application synchronized up to terminal)	No	No	
Interrupts/diagnostics/ status information			
Diagnostic messages			
• Diagnostic functions	Yes	Yes; channel by channel, parameter- izable	Yes
• Diagnostic information readable	Yes	Yes	Yes
• Wire break		Yes; Monitoring, I < 0.3 mA	
• Short circuit	Yes; Sensor supply to M; module by module	Yes	Yes; Sensor supply to M; module by module
• Group error			Yes
Diagnostics indication LED			
• Group error SF (red)	Yes	Yes	Yes
• Status indicator digital input (green)	Yes; Per channel	Yes; Per channel	Yes; Per channel
Parameter			
Diagnostic alarm		Yes	
Hardware interrupt		for 6 channels	
Diagnosis: wire break		channel by channel	
Diagnosis: short circuit	Sensor supply to M; module by mod- ule	channel by channel	
Galvanic isolation			
Galvanic isolation digital inputs			
• between the channels	No	No	No
• between the channels and the backplane bus	Yes	Yes	Yes
Permissible potential difference			
between different circuits	75 VDC / 60 VAC	75 VDC / 60 VAC	75 VDC / 60 VAC
Isolation			
Isolation checked with	500 V DC	500 V DC	500 V DC
Degree and class of protection			
IP65	Yes	Yes	
IP66	Yes	Yes	
IP67	Yes	Yes	Yes
Dimensions			
Width	45 mm	45 mm	45 mm
Height	130 mm	130 mm	130 mm
Depth	35 mm	35 mm; without terminal module	35 mm
Weight			
Weight, approx.	140 g	140 g	140 g

Technical specifications (continued)

	6ES7 142-4BD00-0AA0	6ES7 142-4BD00-0AB0	6ES7 142-4BF00-0AA0
FH technology			
Module for failsafe applications	No	No	No
Supply voltage			
Load voltage 2L+	24 V	24 V	24 V
• Rated value (DC)	24 V	24 V	24 V
• Short-circuit protection	Yes; per channel, electronic	Yes; per channel, electronic	Yes; per channel, electronic
• Reverse polarity protection	Yes; against destruction; load increasing	Yes; against destruction; load increasing	Yes; against destruction; load increasing
Input current			
from load voltage 2L+ (without load), max.	20 mA	40 mA	30 mA
from backplane bus 3.3 V DC, max.	20 mA	40 mA	30 mA
Power losses			
Power loss, typ.	2 W	2.5 W	2 W
Address area			
Address space per module			
• with packing	4 bit	4 bit	8 bit
• without packing	1 byte	1 byte	1 byte
Digital outputs			
Number/binary outputs	4	4	8
Functionality/short-circuit strength	Yes; per channel, electronic	Yes; per channel, electronic	Yes; per channel, electronic
• Response threshold, typ.	3	3	0,7
Limitation of inductive shutdown voltage to	2L+ (-47 V)	2L+ (-47 V)	2L+ (-47 V)
Lamp load, max.	10 W	10 W	5 W
Controlling a digital input	Yes	Yes	Yes; Isolation between 1L+ and 2L+ is no longer provided, as 1M and 2M are jumpered
Load resistance range			
• lower limit	12 Ω	12 Ω	48 Ω
• upper limit	4 kΩ	4 kΩ	4 kΩ
Output voltage			
• for signal "1", min.	2L+ (-0.8 V)	2L+ (-0.8 V)	2L+ (-0.8 V)
Output current			
• for signal "1" rated value	2 A	2 A	0.5 A
• for signal "0" residual current, max.	0.5 mA	0.5 mA	0.5 mA
Parallel switching of 2 outputs			
• for increased power	No	No	No
• for redundant control of a load	Yes	Yes	Yes
Switching frequency			
• with resistive load, max.	100 Hz	100 Hz	100 Hz
• with inductive load, max.	0.5 Hz	0.5 Hz	0.5 Hz
• on lamp load, max.	1 Hz	1 Hz	1 Hz
Aggregate current of outputs (per group)			
• all mounting positions - up to 55 °C, max.	4 A	4 A	4 A
Cable length			
• Cable length, shielded, max.	30 m	30 m	30 m
• Cable length unshielded, max.	30 m	30 m	30 m
Interrupts/diagnostics/ status information			
Substitute values connectable		Yes	
Alarms			
• Diagnostic alarm		Yes	
Diagnostic messages			
• Diagnostic functions	Yes	Yes	Yes
• Diagnostic information readable	Yes	Yes	Yes
• Wire break		Yes	
• Short circuit	Yes; Short-circuit of outputs to ground; module by module	Yes	Yes; Short-circuit of outputs to ground; module by module

SIMATIC ET 200 distributed I/O

ET 200pro

I/O modules
Digital expansion modules

Technical specifications (continued)

	6ES7 142-4BD00-0AA0	6ES7 142-4BD00-0AB0	6ES7 142-4BF00-0AA0
Diagnostics indication LED			
• Group error SF (red)	Yes	Yes	Yes
• Status indicator digital output (green)	Yes	Yes	Yes
• Channel error indicator F (red)		Yes	
Parameter			
Diagnosis: wire break		channel by channel	
Diagnosis: short circuit		channel by channel	
Behavior on CPU/Master STOP		channel by channel	
Galvanic isolation			
between backplane bus and all other circuit components		Yes	
between the channels and backplane bus		Yes	
Galvanic isolation digital outputs			
• between the channels	No	No	No
• between the channels and the backplane bus	Yes	Yes	Yes
Permissible potential difference			
between different circuits		75 VDC / 60 VAC	
Isolation			
Isolation checked with	500 V DC	500 V DC	500 V DC
Dimensions			
Width	45 mm	45 mm	45 mm
Height	130 mm	130 mm	130 mm
Depth	35 mm	35 mm; without terminal module	35 mm
Weight			
Weight, approx.	140 g	140 g	140 g
	6ES7 143-4BF50-0AA0	6ES7 143-4BF00-0AA0	
Supply voltage			
24 V DC	Yes	Yes	
permissible range, lower limit (DC)	20.4 V	20.4 V	
permissible range, upper limit (DC)	28.8 V	28.8 V	
Reverse polarity protection	Yes	Yes; Against destruction; encoder power supply outputs applied with reversed polarity	
Load voltage 2L+			
• Rated value (DC)	24 V	24 V	
• permissible range, lower limit (DC)	20.4 V	20.4 V	
• permissible range, upper limit (DC)	28.8 V	28.8 V	
• Reverse polarity protection	Yes	Yes; against destruction; load increasing	
Input current			
from load voltage 1L+ (unswitched voltage)		20 mA	
from load voltage 2L+, max.	20 mA	20 mA	
Encoder supply			
Number of outputs	4	4	
Output current, rated value	1 A; per module, electronic	1 A; per module, electronic	
24 V encoder supply			
• Short-circuit protection	Yes; per module, electronic	Yes; per module, electronic	
Power losses			
Power loss, typ.	2 W	3 W	
Digital inputs			
Number/binary inputs	4	4; 4 DIOs can be parameterized	
Input characteristic curve acc. to IEC 61131, Type 3	Yes	Yes	

Technical specifications (continued)

	6ES7 143-4BF50-0AA0	6ES7 143-4BF00-0AA0
Number of simultaneously controllable inputs • all mounting positions - up to 60 °C, max.		4; Up to 55 °C
Input voltage • Rated value, DC • for signal "0" • for signal "1"	24 V -3 to +5 V 11 to 30 V	24 V -3 to +5 V 11 to 30 V
Input current • for signal "0", max. (permissible quiescent current) • for signal "1", typ.	1.5 mA 7 mA	1.5 mA 7 mA
Input delay (for rated value of input voltage) • for standard inputs - at "0" to "1", max. - at "1" to "0", max.	3 ms 3 ms	4.8 ms 4.8 ms
Cable length • Cable length unshielded, max.	30 m	30 m
Digital outputs		
Number/binary outputs • In groups of	4	8; 4 DO fixed, 4 DIO parameterizable 2; 2 load groups for 4 outputs each
Functionality/short-circuit strength • Response threshold, typ.	Yes; per channel, electronic 0.7 A	Yes; per channel, electronic 0.7 A
Limitation of inductive shutdown voltage to	Typ. (2L+) -47 V	Typ. (L1+, L2+) -47 V
Controlling a digital input	Yes	Yes
Switching capacity of the outputs • on lamp load, max.	5 W	5 W
Output current • for signal "1" rated value • for signal "0" residual current, max.	0.5 A 0.5 mA	0.5 A 0.5 mA
Parallel switching of 2 outputs • for increased power • for redundant control of a load	No Yes	No Yes
Switching frequency • with resistive load, max. • with inductive load, max. • on lamp load, max.	100 Hz 0.5 Hz 1 Hz	100 Hz 0.5 Hz 1 Hz
Aggregate current of outputs (per group) • all mounting positions - up to 55 °C, max.	2 A	2 A
Cable length • Cable length unshielded, max.	30 m	30 m
Interrupts/diagnostics/status information		
Status indicator	Yes; Green LED	Yes; Green LED
Alarms • Diagnostic alarm	Yes	Yes
Diagnostic messages • Diagnostic functions • Diagnostic information readable • Short circuit • Short circuit encoder supply • Group error	Yes Yes Yes; Short-circuit of outputs to ground; module by module Yes; per module Yes	Yes Yes Yes; Short-circuit of outputs to ground; module by module Yes; per module Yes
Galvanic isolation		
between the load voltages	Yes	Yes
between load voltage and all other switching components	Yes	Yes
Galvanic isolation digital inputs • between the channels	No	No
Permissible potential difference between different circuits	75 VDC / 60 VAC	75 VDC / 60 VAC

SIMATIC ET 200 distributed I/O

ET 200pro

I/O modules
Digital expansion modules

Technical specifications (continued)

	6ES7 143-4BF50-0AA0	6ES7 143-4BF00-0AA0
Isolation tested with • 24 V DC circuits	500 V	500 V
Dimensions		
Width	45 mm	45 mm
Height	130 mm	130 mm
Depth	35 mm	35 mm
Weight Weight	140 g	140 g

Ordering data

Ordering data	Order No.	Ordering data	Order No.
8 DI digital input module 24 V DC, with module-specific diagnostics, including bus module. Connection module must be ordered separately	6ES7 141-4BF00-0AA0	CM IO 4 x M12 P connection module 4 M12 sockets for connecting digital sensors/actuators to ET 200pro; plastic version	6ES7 194-4CA10-0AA0
8 DI High Feature digital input module 24 V DC, with channel-specific diagnostics, including bus module. Connection module must be ordered separately	6ES7 141-4BF00-0AB0	CM IO 8 x M12 connection module 8 M12 sockets for connecting digital sensors or actuators to ET 200pro	6ES7 194-4CB00-0AA0
16 DI digital input module 24 V DC, with module-specific diagnostics, including bus module. Connection module 6ES7 194-4CB50-0AA0 must be ordered separately	6ES7 141-4BH00-0AA0	CM IO 8 x M12 P connection module 8 M12 sockets for connecting digital sensors/actuators to ET 200pro; plastic version	6ES7 194-4CB10-0AA0
4 DO digital output module 24 V DC, 2 A, with module-specific diagnostics, including bus module. Connection module must be ordered separately	6ES7 142-4BD00-0AA0	CM IO 8 x M12D connection module 8 M12 sockets for connecting digital sensors or actuators to ET 200pro	6ES7 194-4CB50-0AA0
4 DO High Feature digital output module 24 V DC, 2 A, with channel-specific diagnostics, including bus module. Connection module must be ordered separately	6ES7 142-4BD00-0AB0	CM IO 8 x M8 connection module 8 sockets M8 for connection of digital sensors or actuators to ET 200pro	6ES7 194-4EB00-0AA0
8 DO digital output module 24 V DC, 0.5 A, with module-specific diagnostics, including bus module. Connection module must be ordered separately	6ES7 142-4BF00-0AA0	CM IO 2 x M12 connection module 2 M12 8-pin sockets; for use with: EM 8 DI, 24 V DC and 8 DO, 24 V DC/0.5 A	6ES7 194-4FB00-0AA0
4 DI/4 DO digital input and output module 24 V DC, 0.5 A, with module-specific diagnostics, including bus module. Connection module must be ordered separately	6ES7 143-4BF50-0AA0	CM IO 1 x M23 connection module 1 socket M23; for use with: EM 8 DI, 24 V DC and 8 DO, 24 V DC/0.5 A	6ES7 194-4FA00-0AA0
4 DIO / 4 DO digital input and output module 24 V DC, 0.5 A, with module-specific diagnostics, including bus module. Connection module must be ordered separately	6ES7 143-4BF00-0AA0	Module identification labels For color coding of the CM IOs in the colors of white, red, blue and green; pack with 100 units each	6ES7 194-4HA00-0AA0
Accessories		M12 sealing cap For protection of unused M12 connections with ET 200pro	3RX9 802-0AA00
CM IO 4 x M12 connection module 4 M12 sockets for connecting digital or analog sensors or actuators to ET 200pro	6ES7 194-4CA00-0AA0	Labels 20 x 7, pale turquoise, 340 items per pack	3RT1 900-1SB20
CM IO 4 x M12 inverse connection module 4 sockets M12 for connection of digital actuators to ET 200pro (4 DO and 4 DO HF); 2 x M12 singly occupied, 2 x M12 doubly occupied	6ES7 194-4CA50-0AA0	Y circular connector M12 For double connection of sensors via a single cable, 5-pole; cannot be used for F DI 4/8	6ES7 194-1KA01-0XA0
		Y cable M12 For double connection of I/O by means of a single-cable on ET200, 5-pole	6ES7 194-6KA00-0XA0
		M8 sealing cap For IP 67 modules	3RK1 901-1PN00

Overview



- Expansion modules with analog inputs and outputs for connecting sensors/actuators
- With diagnostics functionality, limit values and substitute values

Technical specifications

	6ES7 144-4FF00-0AB0	6ES7 144-4GF00-0AB0	6ES7 144-4JF00-0AB0	6ES7 144-4PF00-0AB0
Supply voltage				
Load voltage L+	24 V	24 V	24 V	24 V
• Rated value (DC)	Yes; against destruction	Yes; against destruction	Yes; against destruction	Yes; against destruction
• Reverse polarity protection				
Input current				
from load voltage L+ (without load), max.				34 mA; typ.
from backplane bus 3.3 V DC, max.	10 mA	10 mA	10 mA; typ.	20 mA; typ.
Encoder supply				
Output current				
• Short-circuit protection	Yes; per module, electronic to frame	Yes; per module, electronic to frame		
Power losses				
Power loss, typ.	1.1 W	1.1 W	0.7 W	0.7 W
Address area				
Address space per module				
• Address space per module, max.	8 byte	8 byte	8 byte	8 byte
Analog inputs				
Number of analog inputs	4	4	4	4
permissible input voltage for voltage input (destruction limit), max.	35 V			20 V
permissible input current for current input (destruction limit), max.		40 mA		
Constant measurement current for resistance-type transmitter, typ.			1.25 mA; 1.25 / 0.5 mA depending on measuring range	
Cycle time (all channels) max.	267 ms	267 ms	83 ms; 83 ms at 50 Hz; 69 ms at 60 Hz	Number of active channels per module x basic conversion time
Technical unit for temperature measurement adjustable			Yes	
Input ranges				
• Voltage	Yes	Yes	No	Yes
• Current	No	Yes	No	
• Thermocouple	No	No	No	Yes
• Resistance thermometer	No	No	Yes	
• Resistance	No	No	Yes	

SIMATIC ET 200 distributed I/O

ET 200pro

I/O modules
Analog expansion modules

Technical specifications (continued)

	6ES7 144-4FF00-0AB0	6ES7 144-4GF00-0AB0	6ES7 144-4JF00-0AB0	6ES7 144-4PF00-0AB0
Input ranges (rated values), voltages				
• 1 to 5 V	Yes			
• -10 V to +10 V	Yes			
• Input resistance (-10 V to +10 V)	100 kΩ			
• -5 V to +5 V	Yes			
• -80 mV to +80 mV				Yes
• Input resistance (-80 mV to +80 mV)				10 MΩ
Input ranges (rated values), currents				
• -20 to +20 mA		Yes		
• Input resistance (-20 to +20 mA)		50 Ω		
• 4 to 20 mA		Yes		
• Input resistance (4 to 20 mA)		50 Ω		
Input ranges (rated values), thermoelements				
• Type B				Yes
• Input resistance (Type B)				10 MΩ
• Type E				Yes
• Input resistance (Type E)				10 MΩ
• Type J				Yes
• Input resistance (type J)				10 MΩ
• Type K				Yes
• Input resistance (Type K)				10 MΩ
• Type L				Yes
• Input resistance (Type L)				10 MΩ
• Type N				Yes
• Input resistance (Type N)				10 MΩ
• Type R				Yes
• Input resistance (Type R)				10 MΩ
• Type S				Yes
• Input resistance (Type S)				10 MΩ
• Type T				Yes
• Input resistance (Type T)				10 MΩ
Input ranges (rated values), resistance thermometers				
• Cu 10			No	
• Ni 100			Yes	
• Input resistance (Ni 100)			10 000 kΩ	
• Ni 1000			Yes	
• Input resistance (Ni 1000)			10 000 kΩ	
• Ni 120			Yes	
• Input resistance (Ni 120)			10 000 kΩ	
• Ni 200			Yes	
• Input resistance (Ni 200)			10 000 kΩ	
• Ni 500			Yes	
• Input resistance (Ni 500)			10 000 kΩ	
• Pt 100			Yes	
• Input resistance (Pt 100)			10 000 kΩ	
• Pt 1000			Yes	
• Input resistance (Pt 1000)			10 000 kΩ	
• Pt 200			Yes	
• Input resistance (Pt 200)			10 000 kΩ	
• Pt 500			Yes	
• Input resistance (Pt 500)			10 000 kΩ	
Input ranges (rated values), resistors				
• 0 to 150 ohms			Yes	
• Input resistance (0 to 150 ohms)			10 000 kΩ	
• 0 to 300 ohms			Yes	
• Input resistance (0 to 300 ohms)			10 000 kΩ	
• 0 to 600 ohms			Yes	
• Input resistance (0 to 600 ohms)			10 000 kΩ	
• 0 to 3000 ohms			Yes	
• Input resistance (0 to 3000 ohms)			10 000 kΩ	

Technical specifications (continued)

	6ES7 144-4FF00-0AB0	6ES7 144-4GF00-0AB0	6ES7 144-4JF00-0AB0	6ES7 144-4PF00-0AB0
Thermocouple (TC) • Temperature compensation - internal temperature compensation - external temperature compensation with compensations socket				Yes Yes
Resistance thermometer (RTD) • Characteristic linearization - for resistance thermometer			Ptxxx, Nixxx	
Characteristic linearization • Parameterizable			Yes	
Cable length • Cable length, shielded, max.	30 m	30 m	30 m	30 m
Analog value creation				
Measurement principle	integrating	integrating	integrating	integrating
Integrations and conversion time/ resolution per channel • Resolution with overrange (bit including sign), max. • Integration time, ms • Interference voltage suppression for interference frequency f1 in Hz • Conversion time (per channel)	15 bit; at +/- 10 V, at +/- 5 V; 14 bits at 0 to 10 V, at 1 to 5 V 20 / 16,667 50/60 Hz 67 ms	15 bit; at +/- -20 mA; 14 bits at 0 to 20 mA, 4 to 20 mA 20 / 16,667 50/60 Hz 67 ms	15 bit; at 150, 300, 600 and 3000 ohms; otherwise 15 bits + sign 20 / 16,667 50/60 Hz 20.625 ms; 20.625 ms at 50 Hz; 17.25 ms at 60 Hz	15 bit; + sign 2.5/16.67/20/100 ms 10/50/60/400 Hz 4.7/19/22/102 ms
Smoothing of measured values • Parameterizable • Step: None • Step: low • Step: Medium • Step: High	Yes Yes; 1 x cycle time Yes; 4 x cycle time Yes; 16 x cycle time Yes; 64 x cycle time	Yes Yes; 1 x cycle time Yes; 4 x cycle time Yes; 16 x cycle time Yes; 64 x cycle time	Yes Yes; 1 x cycle time Yes; 4 x cycle time Yes; 16 x cycle time Yes; 64 x cycle time	Yes Yes; 1 x cycle time Yes; 4 x cycle time Yes; 16 x cycle time Yes; 64 x cycle time
Encoder Connection of signal encoders • for current measurement as 2-wire transducer • for current measurement as 4-wire transducer • for resistance measurement with 2-conductor connection • for resistance measurement with 3-conductor connection • for resistance measurement with 4-conductor connection		Yes Yes	 Yes; Line resistances are also measured Yes Yes	
Errors/accuracies				
Linearity error (relative to input area)	+/- 0.01 %	+/- 0.01 %	+/- 0.05 %	
Temperature error (relative to input area)	+/- 0.002 %/K	+/- 0.002 %/K	+/- 0.002 %/K	Positive temperature
Crosstalk between the inputs, min.	-50 dB	-50 dB	-50 dB	-90 dB; max.
Repeat accuracy in settled status at 25 °C (relative to input area)	+/- 0.025 %	+/- 0.025 %	+/- 0.015 %	
Operational limit in overall temperature range • Voltage, relative to input area • Current, relative to input area • Resistance-type thermometer, relative to input area	+/- 0.15 %	+/- 0.15 %	+/- 0.175 %	Positive temperature
Basic error limit (operational limit at 25 °C) • Voltage, relative to input area • Current, relative to input area • Resistance-type thermometer, relative to input area	+/- 0.1 %	+/- 0.1 %	+/- 0.125 %	

SIMATIC ET 200 distributed I/O

ET 200pro

I/O modules
Analog expansion modules

Technical specifications (continued)

	6ES7 144-4FF00-0AB0	6ES7 144-4GF00-0AB0	6ES7 144-4JF00-0AB0	6ES7 144-4PF00-0AB0
Interference voltage suppression for $f = n \times (f_1 \pm 1\%)$, $f_1 =$ interference frequency				
• Series mode interference (peak value of interference < rated value of input range), min.	50 dB	50 dB	50 dB	42 dB
• common mode voltage (USS < 2.5 V), min.	70 dB; Interference voltage < 5 V	70 dB; Interference voltage < 5 V	70 dB; Interference voltage < 5 V	85 dB; Interference voltage < 10 V
Interrupts/diagnostics/status information				
Alarms				
• Diagnostic alarm	Yes; Parameterizable	Yes; Parameterizable	Yes; Parameterizable	Yes; Parameterizable
• Limit value alarm		Yes		
• Hardware interrupt	Yes; (limit value alarm), can be parameterized for channel 0	Yes; (limit value alarm), can be parameterized for channel 0	No	No
Diagnostic messages				
• Diagnostics		Yes		
• Wire break	Yes; at 1 to 5 V	Yes; at 4 to 20 mA	Yes	No
• Short circuit	Yes; at 1 to 5 V	Yes; at 4 to 20 mA		
• Group error		Yes	Yes	
• Overflow/underflow			Yes	Yes
Diagnostics indication LED				
• Group error SF (red)	Yes	Yes	Yes	Yes
Parameter				
Diagnosis: wire break			1	
Load voltage			No	
Measurement type/range			R4L / R3L / R2L / TR4L / TR3L / TR2L	Deactivated/ +/- 80 mV/ TC-EL Type T (Cu-CuNi)/ TC-EL Type K (NiCr-Ni)/ TC-EL Type B (PtRh-PtRh)/ TC-EL Type N (NiCrSi-NiSi)/ TC-EL Type E (NiCr-CuNi)/ TC-EL Type R (PtRh-Pt)/ TC-EL Type S (PtRh-Pt)/ TC-EL Type J (Fe-Cu-Ni)/ TC-EL Type L (Fe-CuNi)
Interference frequency suppression			50/60 Hz	10/50/60/400 Hz
Group diagnostics			1	Yes
Overflow/underflow			1	Yes
Comparison point				None/internal/RTD(0)/dyn. ref. temp./fix. ref. temp.
Unit			Degrees C / Degrees F	°C/°F/K
Galvanic isolation				
Galvanic isolation analog inputs				
• between the channels	No	No	No	No
• between the channels and the backplane bus	Yes	Yes	Yes	Yes
• between the channels and the load voltage L+				Yes
Permissible potential difference				
between the inputs (UCM)			5 Vpp AC	20 Vpp AC
between inputs and MANA (UCM)	5 Vpp AC	5 Vpp AC		
between MANA and M internally (UISO)	500 V DC	500 V DC	500 V DC	
Isolation				
Isolation checked with	500 V DC	500 V DC	500 V DC	500 V DC
Dimensions				
Width	45 mm	45 mm	45 mm	45 mm
Height	130 mm	130 mm	130 mm	130 mm
Depth	35 mm	35 mm	35 mm	35 mm
Weight				
Weight, approx.	150 g	150 g	150 g	150 g

Technical specifications (continued)

	6ES7 145-4FF00-0AB0	6ES7 145-4GF00-0AB0
Supply voltage		
Load voltage L+		
• Rated value (DC)	24 V	24 V
• Reverse polarity protection	Yes; against destruction	Yes; against destruction
Input current		
from backplane bus 3.3 V DC, max.	10 mA	10 mA
Address area		
Address space per module		
• Address space per module, max.	8 byte	8 byte
Analog outputs		
Number of analog outputs	4	4
Voltage output, short-circuit protection	Yes; per channel, electronic to chassis	Yes; per module, electronic to frame
Voltage output, short-circuit current, max.	50 mA	
Current output, no-load voltage, max.		16 V
Cycle time (all channels) max.	3 ms	3 ms
Output ranges, voltage		
• 0 to 10 V	Yes	
• 1 to 5 V	Yes	
• -10 to +10 V	Yes	
Output ranges, current		
• 0 to 20 mA		Yes
• -20 to +20 mA		Yes
• 4 to 20 mA		Yes
Connection of actuators		
• for voltage output 2-conductor connection	Yes	
• for voltage output 4-conductor connection	Yes	
• for current output 2-conductor connection		Yes
• for current output 4-conductor connection		Yes
Load impedance (in rated range of output)		
• with voltage outputs, min.	1 000 Ω	
• with voltage outputs, capacitive load, max.	1 μF	
• with current outputs, max.		600 Ω
• with current outputs, inductive load, max.		1 mH
Destruction limits against externally applied voltages and currents		
• Voltages at the outputs towards MANA	16 V; Permanent	
• Current, max.		100 mA
Cable length		
• Cable length, shielded, max.	30 m	30 m
Analog value creation		
Integrations and conversion time/ resolution per channel		
• Resolution with overrange (bit including sign), max.	15 bit; at -10 to +10 V; 14 bits at 1 to 5 V; 15 bits at 0 to 10 V	15 bit; at +/- 20 mA; 14 bits at 0 to 20 mA; 15 bits at 4 to 20 mA
• Conversion time (per channel)	0.7 ms	0.7 ms
Settling time		
• for resistive load	0.1 ms	0.1 ms
• for capacitive load	6 ms	
• for inductive load		1 ms

SIMATIC ET 200 distributed I/O

ET 200pro

I/O modules

Analog expansion modules

Technical specifications (continued)

	6ES7 145-4FF00-0AB0	6ES7 145-4GF00-0AB0
Errors/accuracies		
Output ripple (based on output area, bandwidth 0 to 50 kHz)	+/- 0.02 %	+/- 0.02 %
Linearity error (relative to output area)	+/- 0.1 %	+/- 0.1 %
Temperature error (relative to output area)	+/- 0.01 %	+/- 0.01 %
Repeat accuracy in settled status at 25 °C (relative to output area)	+/- 0.05 %	+/- 0.05 %
Operational limit in overall temperature range		
• Voltage, relative to output area	+/- 0.2 %	
• Current, relative to output area		+/- 0.2 %
Basic error limit (operational limit at 25 °C)		
• Voltage, relative to output area	+/- 0.15 %	
• Current, relative to output area		+/- 0.15 %
Interrupts/diagnostics/status information		
Substitute values connectable	Yes	Yes
Alarms		
• Diagnostic alarm	Yes; Parameterizable	Yes; Parameterizable
• Hardware interrupt	No	No
Diagnostic messages		
• Diagnostic functions		Yes
• Diagnostic information readable	Yes	
• Wire break	No	Yes; per channel, not in zero range
• Short circuit	Yes; per channel, not in zero range	
• Short circuit encoder supply	Yes; per module	Yes; per module
Diagnostics indication LED		
• Group error SF (red)	Yes	Yes
Parameter		
Output type/range	1	1
Diagnosis: wire break		1
Diagnosis: short circuit	Outputs; sensor supply to M	Encoder supply to M
Group diagnostics	1	1
Behavior on CPU/Master STOP	1	1
Galvanic isolation		
Galvanic isolation analog outputs		
• between the channels	No	No
• between the channels and the backplane bus	Yes	Yes
Dimensions		
Width	45 mm	45 mm
Height	130 mm	130 mm
Depth	35 mm	35 mm
Weight		
Weight, approx.	150 g	150 g

Ordering data	Order No.	Order No.
4AI U analog input module High Feature, ± 10 V; ± 5 V; 0 to 10 V; 1 to 5 V, channel-specific diagnostics, including bus module. Connection module must be ordered separately	6ES7 144-4FF00-0AB0	Accessories CM IO 4 x M12 connection module 6ES7 194-4CA00-0AA0 4 M12 sockets for connecting digital or analog sensors or actuators to ET 200pro M12 compensation connectors 6ES7 194-4AB00-0AA0 with integral PT100 for reference point compensation when connecting thermocouples Module identification labels 6ES7 194-4HA00-0AA0 For color coding of the CM IOs in the colors of white, red, blue and green; pack with 100 units each M12 sealing cap 3RX9 802-0AA00 For protection of unused M12 connections with ET 200pro
4AI I analog input module High Feature, ± 20 mA; 0 to 20 mA; 4 to 20 mA, channel-specific diagnostics, including bus module. Connection module must be ordered separately	6ES7 144-4GF00-0AB0	
4AI RTD analog input module High Feature; resistances: 150, 300, 600 and 3000 Ohm; resistance thermometer: Pt100, 200, 500, 1000, Ni100, 120, 200, 500 and 1000; channel-discrete diagnostics, incl. bus module. Connection module must be ordered separately	6ES7 144-4JF00-0AB0	
Analog input module 4AI TC High Feature; thermocouples: Type B, E, J, K, L, N, R, S, T; voltage measurement: ± 80 mV; channel diagnostics, including bus module. Connection module must be ordered separately	6ES7 144-4PF00-0AB0	
4AO U analog output module High Feature, ± 10 V; 0 to 10 V; 1 to 5 V, channel-specific diagnostics, including bus module. Connection module must be ordered separately	6ES7 145-4FF00-0AB0	
4AO I analog output module High Feature, ± 20 mA; 0 to 20 mA; 4 to 20 mA, channel-specific diagnostics, including bus module. Connection module must be ordered separately	6ES7 145-4GF00-0AB0	

SIMATIC ET 200 distributed I/O

ET 200pro

I/O modules

Fail-safe digital expansion modules

Overview



Fail-safe digital inputs/outputs with degree of protection IP65/66/67 for application on the machine level without control cabinet

Fail-safe digital inputs

- For fail-safe reading of sensor information (1 or 2 channels)
- Provide integral discrepancy evaluation for 2-out-of-2 signals
- Internal sensor supplies (incl. test function) available

Fail-safe digital outputs

- Fail-safe 2-channel activation (sink/source output) by actuators
- Actuators can be driven by up to 2 A

All modules are certified up to Cat. 4 (EN954-1) and up to SIL 3 (IEC 61508) and feature detailed diagnostics.

The modules support PROFIsafe, both in PROFIBUS, and in PROFINET configurations. They can be used with IM 151-7 F-CPU, CPU31xF-2 DP, CPU31xF-2 PN/DP and CPU416F-2.

Technical specifications

	6ES7 148-4FA00-0AB0	6ES7 148-4FC00-0AB0
Digital inputs		
Number/binary inputs	16	8
Dimensions		
Width	90 mm	90 mm
Height	130 mm	130 mm
Depth	65 mm	65 mm

Ordering data

	Order No.
Fail-safe digital input module 8/16 F-DI PROFIsafe 24 V DC, including bus module Connection module must be ordered separately	6ES7 148-4FA00-0AB0
Fail-safe digital input/output module 4/8 F-DI, 4 F-DO 2 A 24 V DC, including bus module Connection module must be ordered separately	6ES7 148-4FC00-0AB0
Fail-safe electronic module F-Switch PROFIsafe Three fail-safe PP-switching outputs for safe switching of the rear panel busbar (2L+, F0, F1); two fail-safe digital inputs, 45 mm; usable up to cat. 4 (EN 954)/SIL3 (IEC 61508)	6ES7 148-4FS00-0AB0

	Order No.
Accessories	
Connection module For the fail-safe electronic module F-switch PROFIsafe	6ES7 194-4DA00-0AA0
Connection module For the fail-safe electronic module 4/8 F-DI/4 F-DO, 24 V DC/2 A	6ES7 194-4DC00-0AA0
Connection module For the fail-safe electronic module 8/16 F-DI, 24 V DC/2 A	6ES7 194-4DD00-0AA0
PROFIBUS DP interface module IM154-2 Including termination module	6ES7 154-2AA01-0AB0
PROFINET interface module IM154-4 PN Including termination module	6ES7 154-4AB10-0AB0
M12 sealing cap For protection of unused M12 connections with ET 200pro	3RX9 802-0AA00

Overview



- PM-E 24 V DC power module

Technical specifications

6ES7 148-4CA00-0AA0	
Supply voltage	
Rated value, 24 V DC	Yes
Load voltage 2L+	
• Short-circuit protection	Yes; via an exchangeable fuse in the power module
• Reverse polarity protection	Yes; against destruction
Current carrying capacity	
Current carrying capacity, max.	10 A; up to 55 °C (on the internal busbars of the ET 200pro)
Interrupts/diagnostics/ status information	
Diagnostic messages	
• Diagnostic functions	Yes
• Diagnostic information readable	Yes
• Missing load voltage	Yes
Diagnostics indication LED	
• Group error SF (red)	Yes
• Load voltage monitoring DC 24 V (green)	Yes
Parameter	
Missing load voltage	Potential group of the power module
Isolation	
Isolation checked with	500 V DC
Degree and class of protection	
IP65	Yes
IP66	Yes
IP67	Yes
Dimensions	
Width	15 mm
Height	81 mm
Depth	52 mm
Weight	
Weight, approx.	35 g

SIMATIC ET 200 distributed I/O

ET 200pro

I/O modules
PM-E power module

Ordering data	Order No.	Order No.	
PM-E 24 V DC power module For backfeed and group formation of the 24 V DC load supply for electronic modules within an ET 200pro station.	6ES7148-4CA00-0AA0		
Accessories CM PM-E ECOFAST connection module For backfeed of 24 V load voltage, 1 ECOFAST Cu connection	6ES7 194-4BA00-0AA0		
CM PM-E direct connection module For backfeed of 24 V load voltage, up to 2 M20 screwed cable glands	6ES7 194-4BC00-0AA0		
CM PM-E 7/8" connection module For backfeed of 24 V load voltage, 1 x 7/8"	6ES7 194-4BD00-0AA0		
CM PM-E PP connection module For supplying 24-V load voltage, 2 x push-pull, with spare fuse	6ES7 194-4BE00-0AA0		
Spare fuse 12.5 A quick-response, for interface and power modules, 10 items per package unit	6ES7 194-4HB00-0AA0		
PROFIBUS ECOFAST hybrid cable, copper Trailing-type cable (PUR casing) with two shielded copper cables for PROFIBUS DP and four copper cores of 1.5 mm ² in cross-section <u>Unassembled</u> <ul style="list-style-type: none"> • 50 m • 100 m <u>Preassembled</u> with ECOFAST male and female connector, fixed length <ul style="list-style-type: none"> • 1.5 m • 3 m • 5 m • 10 m • 15 m • 20 m • 25 m • 30 m • 35 m • 40 m • 45 m • 50 m 	6XV1 830-7AN50 6XV1 830-7AT10 6XV1 830-7BH15 6XV1 830-7BH30 6XV1 830-7BH50 6XV1 830-7BN10 6XV1 830-7BN15 6XV1 830-7BN20 6XV1 830-7BN25 6XV1 830-7BN30 6XV1 830-7BN35 6XV1 830-7BN40 6XV1 830-7BN45 6XV1 830-7BN50	PROFIBUS ECOFAST hybrid cable, GP Trailing-type cable with 4 x copper cores and 2 x copper cores, shielded, with UL approval <u>Unassembled</u> <ul style="list-style-type: none"> • 50 m • 100 m <u>Preassembled</u> with ECOFAST male and female connector <ul style="list-style-type: none"> • 1.5 m • 3 m • 5 m • 10 m • 15 m • 20 m • 25 m • 30 m • 35 m • 40 m • 45 m • 50 m ECOFAST cable connector, for user assembly Female connector; ordering unit 5 items PROFIBUS ECOFAST hybrid plug, angled With 2 x shielded copper cores and 4 x 1.5 mm ² copper cores; 5 items; with assembly instructions; female insert Push-Pull cable connector For 1L+/ 2L+, unassembled Cover caps for Push-Pull female connectors 5 units Accessories for CM PM-E direct Power line 5-core, 5 x 1.5 mm ² , trailing type, sold by the meter, minimum order quantity 20 m, maximum order quantity 1,000 m Accessories for CM PM-E 7/8" 7/8" connecting cable to power supply 5-core, 5 x 1.5 mm ² , trailing type, preassembled with two 7/8" connectors, 5-pin <ul style="list-style-type: none"> • 1.5 m long • 2.0 m long • 3.0 m long • 5.0 m long • 10 m long • 15 m long 7/8" cable connector With axial cable outlet <ul style="list-style-type: none"> • with female insert, 5 per pack 	6XV1 860-4PN50 6XV1 860-4PT10 6XV1 860-3PH15 6XV1 860-3PH30 6XV1 860-3PH50 6XV1 860-3PN10 6XV1 860-3PN15 6XV1 860-3PN20 6XV1 860-3PN25 6XV1 860-3PN30 6XV1 860-3PN35 6XV1 860-3PN40 6XV1 860-3PN45 6XV1 860-3PN50 6GK1 905-0CB00 6GK1 905-0CD00 6GK1 907-0AB10-6AA0 6ES7 194-4JA50-0AA0 6XV1 830-8AH10 6XV1 822-5BH15 6XV1 822-5BH20 6XV1 822-5BH30 6XV1 822-5BH50 6XV1 822-5BN10 6XV1 822-5BN15 6GK1 905-0FB00

Overview



- PM-O 2x 24 VDC power module

Technical specifications

6ES7 148-4CA60-0AA0	
Supply voltage	
Rated value (DC)	24 V
Load voltage 2L+	
• Short-circuit protection	Yes
• Reverse polarity protection	Yes; against destruction
Current carrying capacity	
Current carrying capacity, max.	Output current 2 A for 1L+ and 6 A for 2L+
Interrupts/diagnostics/ status information	
Diagnostic messages	
• Diagnostic functions	Yes
• Diagnostic information readable	Yes
• Fuse blown	No; Indirect diagnostics (short-circuit to M for 1L+), since electronic fuse
• Missing load voltage	No
Diagnostics indication LED	
• Rated load voltage PWR (green)	No
• Group error SF (red)	Yes
• Load voltage monitoring DC 24 V (green)	No; Signalled in IM or in PM
Parameter	
Remark	Diagnosis short circuit implemented after M for 1L+
Galvanic isolation	
primary/secondary	No
Isolation	
Isolation checked with	500 V DC
Degree and class of protection	
IP65	Yes
IP66	Yes
IP67	Yes
Dimensions	
Width	45 mm
Height	130 mm
Depth	35 mm
Weight	
Weight, approx.	150 g

Ordering data

Order No.

PM-O 2 x 24 VDC power module	6ES7148-4CA60-0AA0
For drawing the 24 V load voltage 2L+ and electronic/encoder supply voltage 1L+ within an ET 200pro station.	
Accessories	
CM PM-O PP connection module	6ES7 194-4BH00-0AA0
For drawing the 24 V load voltage and electronic/encoder supply voltage, 2 x push-pull connector	
Push-Pull cable connector	6GK1 907-0AB10-6AA0
For 1L+/ 2L+, unassembled	
Cover caps for Push-Pull female connectors	6ES7 194-4JA50-0AA0
5 units	

SIMATIC ET 200 distributed I/O

ET 200pro

I/O modules ET 200pro pneumatic interface

Overview



- Interface for holding an original FESTO CPV 10 or CPV 14 compact performance valve terminal
- For using the ET 200pro in applications with flexible pneumatics
- Highly flexible pneumatics due to a variety of valve functions and choice of flow rates

Technical specifications

	6ES7 148-4EA00-0AA0	6ES7 148-4EB00-0AA0
Supply voltage		
Load voltage 2L+		
• Rated value (DC)	24 V	24 V
• Short-circuit protection	Yes	Yes
• Reverse polarity protection	Yes	Yes
Input current		
from load voltage 2L+ (without load), max.	20 mA	20 mA
from backplane bus 3.3 V DC, max.	25 mA	25 mA
Power losses		
Power loss, typ.	2.6 W	3.7 W
Address area		
Address space per module		
• without packing	2 byte	2 byte
Digital outputs		
Number/binary outputs	16	16
Load resistance range		
• lower limit	500 Ω	500 Ω
• upper limit	2 500 Ω	2 500 Ω
Output current		
• for signal "1" rated value	12 mA	16 mA
Switching frequency		
• with inductive load, max.	25 Hz	20 Hz
Aggregate current of outputs (per group)		
• all mounting positions - up to 55 °C, max.	250 mA; only up to 50 °C, limited by valves	330 mA; only up to 50 °C, limited by valves
Interrupts/diagnostics/ status information		
Alarms		
• Diagnostic alarm	Yes	Yes
Diagnostic messages		
• Diagnostic functions	Yes	Yes
• Diagnostic information readable	Yes	Yes
Diagnosics indication LED		
• Group error SF (red)	Yes	Yes
• Status indicator digital output (green)	Yes	Yes

Technical specifications (continued)

	6ES7 148-4EA00-0AA0	6ES7 148-4EB00-0AA0
Parameter		
Remark	Diagnosis load voltage 2L+	Diagnosis load voltage 2L+
Behavior on CPU/Master STOP	No	
Galvanic isolation between backplane bus and all other circuit components	Yes	Yes
between the channels and backplane bus	Yes	Yes
Galvanic isolation digital outputs • between the channels and the backplane bus	Yes	Yes
Permissible potential difference between different circuits	75 VDC / 60 VAC	75 VDC / 60 VAC
Isolation		
Isolation checked with	500 V DC	500 V DC
tested with • Load voltage L+ against backplane bus	500 V DC	500 V DC
Dimensions		
Width	90 mm	120 mm
Height	130 mm	152 mm
Depth	47 mm	47 mm

Ordering data**EM 148-P pneumatic interface**

DO 16 x P/CPV 10 for direct accommodation of FESTO valve terminal CPV 10 16 DO x P

DO 16 x P/CPV 14 for direct accommodation of FESTO valve terminal CPV 14 16 DO x P

Order No.**6ES7 148-4EA00-0AA0****6ES7 148-4EB00-0AA0**

FESTO CPV10 valve terminal

FESTO CPV 14 valve terminal

Order No.

available from FESTO

available from FESTO

FESTO AG & Co
Ruiterstr. 82
D-73732 Esslingen

More addresses
on Internet at:
<http://www.festo.de>

SIMATIC ET 200 distributed I/O

ET 200pro

I/O modules
SIMATIC RF170C

Overview



The SIMATIC RF170C is a communication module for connecting the SIMATIC identification systems to the ET 200pro distributed I/O system. The readers (SLGs) of all RFID systems as well as the MV400 code-reading systems can be operated on the SIMATIC RF170C.

Thanks to its high degree of protection and ruggedness, ET 200pro is particularly suitable for machine-level use. The modular structure with PROFIBUS and PROFINET connection systems allows them to be used in all applications. The uniform plug-in connection system ensures rapid commissioning.

Technical specifications

Order No.	6GT2 002-0HD00
Product-type designation	RF170C communication module
Suitability for installation	
Transmission rate at point-to-point connection serial maximum	115.2 kbit/s
Interfaces	
Design of interface for point-to-point connection	RS422 via connection block
Number of readers connectable	2
Design of electrical connection	ET 200pro backplane bus (according to the head module)
<ul style="list-style-type: none"> of the backplane bus of the PROFIBUS interface the Industrial Ethernet Interface for supply voltage 	ET 200pro backplane bus (according to the head module)
Version of the interface to the reader for communication	Internal plug to the connection block
Mechanical data	
Material	Thermoplastic (Valox 467, fiberglass reinforced)
Color	IP Basic 714
Tightening torque of screw for mounting the equipment maximum	1.5 N·m
Supply voltage, current consumption, power loss	
Supply voltage for DC	24 V
<ul style="list-style-type: none"> rated value minimum maximum 	20 V 30 V
Current consumed at 24 V DC	0.13 A
<ul style="list-style-type: none"> without connected devices typical including connected devices maximum 	1 A
Permitted ambient conditions	
Ambient temperature	-25 ... +55 °C
<ul style="list-style-type: none"> during operating during storage during transport 	-40 ... +70 °C -40 ... +70 °C

Order No.	6GT2 002-0HD00
Product-type designation	RF170C communication module
Protection class IP	
Resistance against shock	According to IEC 61131-2
Resistance against shock	300 m/s ²
Resistance against vibration	100 m/s ²
Design, dimensions and weight	
Width	90 mm
Height	130 mm
Depth	35 mm
Net weight	0.27 kg
Type of mounting	ET 200pro rack
Cable length for RS 422 interface maximum	1000 m
Product properties, functions, components general	
Type of display	(see connection block)
Product function transponder file handler can be addressed	No
Protocol will be supported S7 communication	Yes
Product functions management, configuration	
Type of parameterization	HSP
Type of programming	FB 45, FB 55 (FC 45/55 with limited functionality)
Type of computer-mediated communication	acyclic communication
Standards, specifications, approvals	
Verification of suitability	CE, FCC, cULus
Accessories	
Accessories	Connection block for RF170C

Technical specifications (continued)		Ordering data	Order No.
Order No.	6GT2 002-1HD00	SIMATIC RF170C communication module	6GT2 002-0HD00
Product-type designation	Connection block for RF170C	For connecting to the distributed I/O system ET 200pro	
Suitability for installation		Accessories	
Interfaces		Connection block for SIMATIC RF170C	6GT2 002-1HD00
Design of interface for point-to-point connection	RS422	For connecting 2 readers via an M12 connector	
Number of readers connectable	2	Reader cable for MOBY U PUR material, CMG approved, suitable for cable carriers	
Mechanical data		2 m	6GT2 091-4FH20
Material	Die-cast zinc	5 m	6GT2 091-4FH50
Color	Silver	Reader cable for MOBY D PUR material, CMG approved, suitable for cable carriers, 2 m	6GT2 691-4FH20
Tightening torque of screw for mounting the equipment maximum	1.5 N·m	Reader cable for SIMATIC RF200 / RF300 / RF600 / MV400 Or extension cable MOBY U/D and SIMATIC RF200 / RF300 / RF600 / MV400, PUR material, CMG approved, suitable for cable carriers, straight connector	
Supply voltage, current consumption, power loss		2 m	6GT2 891-4FH20
Supply voltage for DC rated value	24 V	5 m	6GT2 891-4FH50
Supply voltage • for DC	20 ... 30 V	M12 sealing caps for unused reader connections 10 units minimum order quantity, price per 100 units	3RX9 802-0AA00
Permitted ambient conditions		DVD "RFID Systems Software & Documentation"	6GT2 080-2AA20
Ambient temperature			
• during operating	-25 ... +55 °C		
• during storage	-40 ... +70 °C		
• during transport	-40 ... +70 °C		
Protection class IP			
Resistance against shock	According to IEC 61131-2		
Resistance against shock	300 m/s ²		
Resistance against vibration	100 m/s ²		
Design, dimensions and weight			
Width	90 mm		
Height	130 mm		
Depth	25 mm		
Net weight	0.5 kg		
Type of mounting	4 screws included		
Product properties, functions, components general			
Type of display	4 LEDs per reader connection, 1 LEDs for device status		
Standards, specifications, approvals			
Accessories			
Accessories	-		

SIMATIC ET 200 distributed I/O

ET 200pro

SIMATIC ET200pro PS

Application



The SIMATIC ET200pro PS power supply unit with degree of protection IP67 is used as electronics/encoder supply and load voltage supply of the new I/O device. With a signaling contact for "24 V OK" and "Overtemperature", as well as a second plug-in connector for input voltage loop-through.

Technical specifications

Order No.	6ES7 148-4PC00-0HA0
Product	SIMATIC ET200pro PS
Power supply, type	24 V/8 A
Input	
Input	3-phase AC
Rated voltage value V_{in} rated	400 ... 480 V
Note	320 ... 340 V for max. 1 min
Voltage range	340 ... 550 V
Overvoltage resistance	Implemented internally with varistors
Mains buffering at I_{out} rated, min.	15 ms
Mains buffering	at $V_{in} = 400$ V
Rated line frequency	<ul style="list-style-type: none"> • 1 50 Hz • 2 60 Hz
Rated line range	45 ... 66 Hz
Input current at nominal level of the input voltage 400 V nominal value	0.5 A
Switch-on current limiting (+25 °C), max.	40 A
I^2t , max.	3.5 A ² ·s
Built-in incoming fuse	internal, 4 A
Protection in the mains power input (IEC 898)	Required: Circuit breaker 2.2 ... 3.2 A 3RV2011-1DA10 or 3RV2711-1DD10 (UL 489)
Output	
Output	Controlled, isolated DC voltage
Rated voltage V_{out} DC	24 V
Total tolerance, static \pm	3 %
Static mains compensation, approx.	0.5 %
Static load balancing, approx.	0.5 %
Residual ripple peak-peak, max.	200 mV
Spikes peak-peak, max. (bandwidth: 20 MHz)	250 mV
Product feature output voltage adjustable	No
Output voltage setting	-
Status display	Green LED for 24 V OK

Order No.	6ES7 148-4PC00-0HA0
Product	SIMATIC ET200pro PS
Power supply, type	24 V/8 A
Signaling	max. 30 V, 10 mA; Power-Good (High-Pegel 1L+ for V_{out} in range 21.3 ... 29 V); Overtemperature warning at least 30 s before switch-off (high level 1L+ when the max. internal temperature is exceeded)
On/off behavior	Overshoot of $V_{out} < 2$ %
Startup delay, max.	1.5 s
Voltage rise, typ.	40 ms
Rated current value I_{out} rated	8 A
Current range	0 ... 8 A
delivered active power typ.	192 W
short-term overload current at short-circuit during run-up typical	50 A
Duration of overloading ability for excess current on short-circuiting during the start-up	100 ms
short-term overload current at short-circuit during operation typical	50 A
Duration of overloading ability for excess current on short-circuiting during the operational phase	100 ms
Parallel switching for enhanced performance	No
Efficiency	
Efficiency at V_{out} rated, I_{out} rated, approx.	88 %
Power loss at V_{out} rated, I_{out} rated, approx.	25 W
Closed-loop control	
Dynamic mains compensation (V_{in} rated ± 15 %), max.	0.5 %
Dynamic load smoothing (I_{out} : 50/100/50 %), $U_{out} \pm$ typ.	1 %
Setting time maximum	2 ms

Technical specifications (continued)

Order No.	6ES7 148-4PC00-0HA0
Product	SIMATIC ET200pro PS
Power supply, type	24 V/8 A
Protection and monitoring	
Output overvoltage protection	< 33 V
Current limitation, typ.	9.4 A
Characteristic feature of the output short-circuit protected	Yes
Short-circuit protection	Electronic shutdown, a automatic restart
Enduring short circuit current Effective level maximum	10 A
Overload/short-circuit indicator	-
Safety	
Primary/secondary isolation	Yes
Potential separation	Protective extra low output voltage Vout according to EN 60950-1 and EN 50178
Protection class	Class I
Stray current	
• maximum	3.5 mA
• typical	0.4 mA
CE mark	Yes
UL/CSA approval	No
UL/cUL (CSA) approval	in preparation UL-Listed (UL 508)
Explosion protection	-
FM approval	No
FM approval	-
CB approval	Yes
Marine approval	-
Degree of protection (EN 60529)	IP67, enclosure type 4 indoor
EMC	
Emitted interference	EN 55022 Class A
Supply harmonics limitation	-
Noise immunity	EN 61000-6-2

Order No.	6ES7 148-4PC00-0HA0
Product	SIMATIC ET200pro PS
Power supply, type	24 V/8 A
Operating data	
Ambient temperature	
• in operation	-25 ... +55 °C
- Note	with natural convection
Ambient temperature	
• on transport	-40 ... +70 °C
Ambient temperature	
• in storage	-40 ... +70 °C
Humidity class according to EN 60721	Climate class 3K3, no condensation
Mechanics	
Connection technology	screw-type terminals
Connections	
• Supply input	L1, L2, L3, PE: Plug connector HAN Q4/2
• Output	L+, M: 2 x 1.5 mm ² each (4-pole cable for +/- with open, labeled ends, 4 x 1.5 mm ²)
• Auxiliary	Alarm signals: M12 plug-in connector 5-pin
Width of the housing	310 mm
Height of the housing	135 mm
Depth of the housing	90 mm
Weight, approx.	2.8 kg
Product feature of the housing housing for side-by-side mounting	No
Type of mounting wall mounting	Yes
Type of fixing cap rail mounting	No
Type of mounting S7-300 rail mounting	No
Installation	Can be mounted onto ET200pro mounting rail
Electrical accessories	Power connector (Input: 3RK1911-2BE30 (6 mm ²)) (Output: 3RK1911-2BF10 (4 mm ²))

Ordering data

SIMATIC ET 200pro PS	6ES7 148-4PC00-0HA0
Stabilized power supply in the design of the distributed I/O system, permitting the loop-through of energy to further modules; with degree of protection IP67; input: 400-480 V 3 AC Output: 24 V DC/8 A	

Accessories	Order No.
Power connection plug	
For connecting to the distributed I/O system	
• For X1 (6 mm ²)	3RK1 911-2BE30
• For X2 (6 mm ²)	3RK1 911-2BF10
Sealing cap	
For 9-pole power sockets	
• X2 (1 unit)	3RK1 902-0CJ0
• X2 (10 units)	3RK1 902-0CK00

SIMATIC ET 200 distributed I/O

ET 200pro

ET 200pro motor starters General data

Overview

ET 200pro motor starters in I/O system ET 200pro

SIMATIC ET 200pro is the modular I/O system with high IP65/66/67 degree of protection for local, cabinet-free use. The ET 200pro motor starters with the high degree of protection IP65 are an integral part of ET 200pro.



ET 200pro motor starters: Isolator module, Standard starter and High Feature starter mounted on a wide module rack

ET 200pro motor starters

- Only two versions up to 5.5 kW
- All settings can be parameterized by bus
- Comprehensive diagnostic messages
- Support for PROFlenergy
- Overload can be acknowledged by remote reset
- Current unbalance monitoring
- Blocking protection
- Emergency start function in the event of overload
- Current value transmission by bus
- Current limit monitoring
- Full support of acyclic services
- Direct-on-line or reversing starters
- Power bus connection can be plugged in using Han Q4/2 plug-in connectors
- Motor feeder with Han Q8/0 connector
- Conductor cross-section up to 6 x 4 mm²
- 25 A per segment (power looped through using jumper plug)
- In the Standard and High Feature versions (with 4 DI onBoard)
- Electromechanical switching and electronic switching
- Electronic direct-on-line starter or with integrated soft starter function
- Supplied with 400 V AC brake contact as an option
- Provision of the motor current in PROFlenergy format to higher-level systems, motor current shutdown in dead times using PROFlenergy

ET 200pro isolator modules (see page 9/301)

The isolator module with switch disconnecter function is used for safe disconnection of the 400 V operational voltage during repair work in the plant and provides an integrated group fusing function (i. e. additional group short-circuit protection for all subsequently supplied motor starters).

Depending on the power distribution concept, all stations can be equipped with an isolator module as an option.

Safety applications

Safety Solution local (see page 9/302)

With the Safety local modules

- Safety local isolator module and

- 400 V disconnecting module safety levels SIL 3 (according to IEC 62061) and PL e (according to ISO 13849-1) can be achieved with an appropriate connection.

Safety PROFIsafe solution (see page 9/305)

With the Safety PROFIsafe modules

- F-Switch and
- 400 V disconnecting module safety levels SIL 3 (according to IEC 62061) and PL e (according to ISO 13849-1) can also be reached with an appropriate connection.

Functionality

With the ET 200pro motor starters, any three-phase current loads can be protected and switched.

The ET 200pro motor starters are available with mechanical as well as electronic contacts.

The ET 200pro electromechanical starters are offered as direct-on-line starters (DSe) and reversing starters (RSe) in the versions **Standard** and **High Feature**. There are device versions with or without control for externally fed brakes with 400 V AC.

Compared to the Standard motor starter, the **High Feature mechanical motor starter** also has:

- 4 digital inputs
- Advanced parameterization options

The ET 200pro electronic starters are offered as direct-on-line starters (sDSSSte/sDSte) and reversing starters (sRSSSte/sRSte) in the High Feature version:

Compared to the High Feature mechanical motor starter, the **High Feature electronic motor starter** also has :

- Soft starting and soft run-down function
- Deactivated soft start function as an electronic starter for applications with a high switching frequency
- Advanced parameterization options

As a result of the protection concept with electronic overload evaluation and the use of SIRIUS switching devices, size S00, additional advantages are realized on the Standard and High Feature motor starters - advantages which soon make themselves positively felt particularly in manufacturing processes with high plant standstill costs:

- Plant configuration is simplified and flexibility increased thanks to the bit-modular design with ET200pro. When using the ET 200pro motor starters, the list of parts per load feeder is reduced to 2 main items: the bus module and the motor starter. This makes the ET 200pro ideal for modular machine concepts or solutions for conveying systems and in machine-tool building.
- Expansions are easily possible through the subsequent adding of modules. The innovative plug-in technology also does away with the wiring needed up to now. Through the hot swapping function (disconnection and connection during operation), a motor starter can be replaced within seconds if necessary, without having to shut down the ET 200pro station and with it the process in the plant. The motor starters are therefore recommendable in particular for applications with special demands on availability. Storage costs are optimized in addition by the low level of variance (2 units up to 5.5 kW).

The ordering option for motor starters with a 400 V AC brake output provides the possibility of controlling motors with 400 V AC brakes. With four locally acting inputs available on the High Feature motor starter it is possible to realize autonomous special functions which work independently of the bus and the higher level control system, e.g. as a quick stop on gate valve controls or limit position disconnectors. In parallel with this, the states of these inputs are signaled to the control system.

Type Technology designation ¹⁾	Standard motor starters		High Feature motor starters	
	DSe, RSe		DSe, RSe	sDSSSte, sDSte, sRSSSte, sRSte
Device functions (firmware features)				
Parameterizable rated operational current		✓		
Integrated short-circuit protection		✓		
Programmable current limits		--	✓, 2 limit values	
Parameterizable response to current limit violation		--	✓	
Residual current monitoring		✓		
Parameterizable response to residual current violation		✓		
Parameterizable current asymmetry limit	%	--, fixed limit value (30 x I _e)	✓, 30 ... 60 x I _e	
Parameterizable response to asymmetry limit violation		✓		
Motor blocking monitoring		--	✓	
Parameterizable blocking current limit	%	--	✓, 150 ... 1 000 x I _e	
Parameterizable blocking time limit	s	--	✓, 1 ... 5	
Current value transmission		✓		
Group warning diagnostics		--	✓, parameterizable	
Group diagnostics		✓, parameterizable		
Emergency start		✓		
Digital inputs		--	✓, 4 inputs	
• Parameterizable input signal		--	✓, latching/non-latching	
• Parameterizable input level		--	✓, NC/NO	
• Parameterizable input signal delay	ms	--	✓, 10 ... 80	
• Parameterizable input signal extension	ms	--	✓, 0 ... 200	
• Parameterizable input control actions		--	✓, 12 different actions	
Brake output (400 V AC)		✓, order option		
Parameterizable brake release delay	s	✓, -2.5 ... 2.5		
Parameterizable brake holding time during stopping	s	✓, 0 ... 25		
Parameterizable starting mode		--		✓
Parameterizable stopping time		--		✓
Parameterizable start voltage		--		✓
Parameterizable stop voltage		--		✓
Local device interface		✓		
Firmware update		✓, by specialists		
Thermal motor model		✓		
Parameterizable trip class		--, CLASS 10 fixed	✓, CLASS 5, 10, 15, 20	
Parameterizable response to overload of thermal motor model		--	✓, 3 possible states	
Prewarning limit motor heating	%	--	✓, parameterizable 0 ... 95	
Prewarning limit remaining time for tripping	s	--	✓, parameterizable 0 ... 500	
Parameterizable recovery time	min	--	✓, 1 ... 30	
Parameterizable protection against voltage failure		--, permanently integrated	✓	
Reversing start function		✓, order option		
Parameterizable interlocking time for reversing starters		--, 150 ms fixed	✓, 0 ... 60 s	
Integrated logbook functions		✓, 3 device logbooks		
Integrated statistics data memory		✓		
Parameterizable response to CPU/master STOP		✓		
PROEnergy profile support		✓		
• Disconnection of the motor current during idle times		✓		
• Measured motor current values		✓		
Device displays		SF LED (red)		
• Group error		STATE LED (red; yellow, green)		
• Switching status		DEVICE LED (red; yellow, green)		
• Device status		--		
• Digital inputs		--	IN 1 ... IN 4, LED	

✓ Function is available

-- Function is not available

1) DS direct-on-line starter

RS reversing starter

DSS .. direct soft starter

RSS .. reversing starter

e electronic motor protection

te full motor protection (thermal + electronic)

s electronic switching with semiconductor

SIMATIC ET 200 distributed I/O

ET 200pro

ET 200pro motor starters
General data

Technical specifications

Type	Standard motor starters		High Feature motor starters	
	Mechanical switching without inputs		Mechanical switching with inputs	Electronic switching with inputs and soft starter function
Technology designation ¹⁾	DSe, RSe		DSe, RSe	sDSSSte, sDSte, sRSSSte, sRSte
Mechanical components and environment				
Motor starters or modules that can be connected to ET 200pro with width of 110 mm	max. 8			
Mounting dimensions (W x H x D) • Direct-on-line starters and reversing starters	mm	110 x 230 x 150	110 x 230 x 160	
Permissible ambient temperature • During operation • During storage	°C	-25 ... +55, from +40 with derating		
	°C	-40 ... +70		
Permissible mounting position	Vertical, horizontal			
Vibration resistance acc. to IEC 60068, parts 2-6	g	2		
Shock resistance acc. to IEC 60068, parts 2-27	g/ms	Half-wave 15/11		
Degree of protection	IP65			
Degree of pollution	3, IEC 60664 (IEC 61131)			
Electrical data				
Current consumption at 24 V DC • From auxiliary circuit L+/M (U1) • From auxiliary circuit A1/A2 (U2)	mA	approx. 40		
	mA	approx. 200		
Rated operational current for power bus I_e	A	25		
Rated operational voltage U_e • Approval according to EN 60947-1, Annex N • Approval according to CSA and UL	V AC	400 (50/60 Hz)		
	V AC	Up to 400 (50/60 Hz)		Up to 400 (50/60 Hz)
	V AC	Up to 600 (50/60 Hz)		Up to 480 (50/60 Hz)
Approval • DIN VDE 0106, part 101 • CSA and UL approval	V	Up to 400		Up to 480
	V	Up to 600		Up to 480
Conductor cross-sections • Incoming energy supply	mm ²	max. 6 x 4		
Touch protection	Safe from finger-touch			
Rated impulse withstand voltage U_{imp}	kV	6		
Rated insulation voltage U_i	V	400		
Rated operational current for starters I_e • AC-1/2/3 at 40 °C - At 400 V - At 500 V • AC-4 at 40 °C - At 400 V	A	0.15 ... 2.0/1.5 ... 12.0		0.15 ... 2.0/1.5 ... 12.0 ²⁾
	A	0.15 ... 2.0/1.5 ... 9.0		
	A	0.15 ... 2.0/1.5 ... 4.0		
Rated short-circuit breaking capacity	kA	100 at 400 V		
Type of coordination according to IEC 60947-4-1	1			
Power of three-phase motors at 400 V	kW	max. 5.5		max. 5.5/4 ³⁾
Utilization categories	AC-1, AC-2, AC-3, AC-4		AC-53a ⁴⁾ (max. 9 A with deactivated soft start function up to CLASS 10)	
Protective separation between main and auxiliary circuits	V	400, according to EN 60947-1, Annex N		
Endurance of contactor • mechanical	Operat- ing cycles	30 million		--
• Electrical	Operat- ing cycles	Up to 10 million; depending on the current load (see manual ⁵⁾)		--
Permissible switching frequency	Depending on the current load, motor starting time, and relative ON period (see manual ⁵⁾)			
Operating times at 0.85 ... 1.1 x U_e • Closing delay • Opening delay	ms	11 ... 50		--
	ms	5 ... 45		--

1) DS direct-on-line starter
RS reversing starter
DSS .. direct soft starter
RSS .. reversing starter
e electronic motor protection
te full motor protection (thermal + electronic)
s electronic switching with semiconductor

2) **Note:**
If the soft starter control function is deactivated, the permissible rated operational current is reduced to 9 A up to CLASS 10.

3) If parameterized as electronic starter max. 4 kW.

4) 8-hour operation.

5) <http://support.automation.siemens.com/WWW/view/en/22332388>

Overview

The functionality, device functions, and technical specifications of the Standard motor starter are described in "ET 200pro motor starters, general data" ([see from page 9/296](#)).

Selection and ordering data

Version

Order No.

Standard motor starters, mechanical
Motor protection: thermal model

DSe Standard

DSe direct-on-line starters¹⁾

- Without brake output
- With brake output 400 V AC

3RK1 304-5□S40-4AA0
3RK1 304-5□S40-4AA3

RSe reversing starters¹⁾

- Without brake output
- With brake output 400 V AC

3RK1 304-5□S40-5AA0
3RK1 304-5□S40-5AA3

Setting range
Rated operational current

- 0.15 ... 2.0 A
- 1.5 ... 12.0 A

K
L

¹⁾ Only functions when used together with the backplane bus module and the wide module rack. The backplane bus module and the wide module rack must be ordered separately ([see "Accessories for ET 200pro motor starters" on page 9/310](#)).

SIMATIC ET 200 distributed I/O

ET 200pro

ET 200pro motor starters High Feature motor starters

Overview

The functionality, device functions, and technical specifications of the High Feature motor starter are described in "ET 200pro motor starters, general data" (see from page 9/296).

The High Feature motor starter differs from the Standard motor starter in having more parameters, and four integrated, freely-parameterizable digital inputs.

Selection and ordering data

Version

Order No.

High Feature motor starters, mechanical Motor protection: thermal model



RSe High Feature

DSe direct-on-line starters¹⁾

- Without brake output and with 4 inputs
- With brake output 400 V AC and 4 inputs

3RK1 304-5□S40-2AA0
3RK1 304-5□S40-2AA3

RSe reversing starters¹⁾

- Without brake output and with 4 inputs
- With brake output 400 V AC and 4 inputs

3RK1 304-5□S40-3AA0
3RK1 304-5□S40-3AA3

Setting range
Rated operational current

- 0.15 ... 2.0 A
- 1.5 ... 12.0 A

K
L

High Feature motor starters²⁾, electronic Full motor protection, comprising thermal motor protection and thermistor motor protection



sRSSe High Feature

sDSSe/sDSte direct-on-line starters¹⁾²⁾

- Without brake output and with 4 inputs
- With brake output 400 V AC and 4 inputs

3RK1 304-5□S70-2AA0
3RK1 304-5□S70-2AA3

sRSSe/sRSte reversing starters¹⁾²⁾

- Without brake output and with 4 inputs
- With brake output 400 V AC and 4 inputs

3RK1 304-5□S70-3AA0
3RK1 304-5□S70-3AA3

Setting range
Rated operational current

- 0.15 ... 2.0 A
- 1.5 ... 12.0 A

K
L

¹⁾ Only functions when used together with the backplane bus module and the wide module rack. The backplane bus module and the wide module rack must be ordered separately (see "Accessories for ET 200pro motor starters" on page 9/310).

²⁾ The electronic motor starters can be used not only as electronic motor starters with a high level of switching frequency but also as fully fledged soft starters for soft starting and smooth ramp-down. The changeover from motor starter to soft starter takes place through reparameterization in HW Config. Depending on the setting, this results in the following current ranges:
- Parameterization as electronic motor starter: 0.15 to 2 A and 1.5 to 9 A (4 kW)
- Parameterization as soft starter: 0.15 to 2 A and 1.5 to 12 A (5.5 kW).

Overview

The isolator module with integrated group fusing function (i.e. additional group short-circuit protection for all subsequently supplied motor starters) and switch disconnecter function is used for safe disconnection of the 400 V operational voltage in the plant.

Depending on the power distribution concept, all stations can be equipped with an isolator module as an option.

The following properties apply to the isolator module:

- Increase of plant availability through fast replacement of units (easy mounting and plug-in technology)
- Cabinet-free construction thanks to high degree of protection IP65

The isolator module is available in addition in a safety version (see page 9/302 "Safety local isolator module").

Technical specifications

Type	Isolator module	
General data		
Mounting dimensions (W x H x D)		
• Direct-on-line starters and reversing starters	mm	110 x 230 x 170
Permissible ambient temperature		
• During operation	°C	-25 ... +55
• During storage	°C	-40 ... +70
Permissible mounting position	Any	
Vibration resistance acc. to IEC 60068 parts 2-6	g	2
Shock resistance acc. to IEC 60068, parts 2-27	g/ms	Half-wave 15/11
Current consumption		
• From auxiliary circuit L+/M (U1)	mA	approx. 20
• From auxiliary circuit A1/A2 (U2)	--	--
Rated operational current for power bus I_e	A	25
Rated operational voltage U_e	V	400
Approvals according to		
• DIN VDE 0106, part 101	V	Up to 500
• CSA and UL	V	Up to 600
Conductor cross-sections		
• Incoming energy supply	mm ²	max. 6 x 4

Type	Isolator module	
Degree of protection	IP65	
Touch protection	Safe from finger-touch	
Degree of pollution	3, IEC 60664 (IEC 61131)	
Rated impulse withstand voltage U_{imp}	kV	6
Rated insulation voltage U_i	V	400
Rated operational current for starters I_e		
• AC-1/2/3 at 40 °C		
- At 400 V	A	25
- At 500 V	A	25
Rated short-circuit breaking capacity	kA	50 at 400 V
Type of coordination according to IEC 60947-4-1	2	
Protective separation between main and auxiliary circuits	V	400, according to DIN VDE 0106, part 101
Device functions		
• Group diagnostics	Yes, parameterizable	
Device displays		
• Group error	SF LED (red)	

Selection and ordering data

Version	Order No.
---------	-----------

ET 200pro isolator module, mechanical



3RK1 304-0HS00-6AA0

Isolator module¹⁾
Rated operational current 25 A

3RK1 304-0HS00-6AA0

¹⁾ Only functions when used together with the related 110 mm backplane bus module and the wide module rack. The backplane bus module and the wide module rack must be ordered separately (see page 9/310 "Accessories for ET 200pro motor starters").

SIMATIC ET 200 distributed I/O

ET 200pro

ET 200pro Safety motor starter Solutions local/PROFIsafe – Safety local modules

Overview

Safety Solution local

With the safety local modules

- Safety local isolator module and
 - 400 V disconnecting module
- safety levels SIL 3 (according to IEC 62061) and PL e (according to ISO 13849-1) can be achieved with an appropriate connection.



ET 200pro motor starters (Safety Solution local): Safety local isolator module, disconnecting module, Standard starter and High Feature starter mounted on a wide module rack

Safety local isolator module

The Safety local isolator module is a maintenance switch with integrated safety evaluation functions that can be parameterized using DIP switches.

It is used for

- Connection of a 1 or 2-channel EMERGENCY-STOP circuit up to SIL 3 / PL e (protective door or EMERGENCY-STOP push-buttons) and parameterizable start behavior
- Control of the 400 V disconnecting module by means of a safety rail signal

400 V disconnecting module

The 400 V disconnecting module enables the safe disconnection of an operational voltage of 400 V up to SIL 3 / PL e. For operation in a Safety Solution local application, it functions only in combination with the Safety local isolator module.

For operation in a Safety PROFIsafe application, it functions only in combination with the F-Switch.

Functionality

Safety local isolator module

The Safety local isolator module features the same functions as a standard isolator module with an additional local safety function.

The Safety local isolator module contains a 3TK28 41 module and is equipped with M12 terminals for the connection of external safety components.

Terminals 1 and 2 can be used to connect either 1-channel or 2-channel EMERGENCY-STOP circuits or protective door circuits (IN 1, IN 2).

For monitored starts, an external START switch can be connected to terminal 3.

The required safety functions can be set using 2 slide switches located under the left M12 opening.

In the event of an EMERGENCY-STOP, the Safety local isolator module trips the downstream 400 V disconnecting module. This safely separates the 400 V circuit up to SIL 3 / PL e.

In combination with the 400 V disconnecting module, the Safety local isolator module can be used for safety applications up to SIL 3 a/ PL e.

400 V disconnecting module

The 400 V disconnecting module can be used together with the Safety local isolator module for local safety applications, and together with the F-Switch for PROFIsafe safety applications.

It contains two contactors connected in series for safety-oriented disconnection of the main circuit.

The auxiliary circuit supply of the device is over a safety power rail in the backplane bus module.

The 400 V disconnecting module can be used in conjunction with the Safety local isolator module or with the F-Switch for safety applications up to SIL 3 / PL e.

Technical specifications



Type		Safety local isolator module	400 V disconnecting module
General data			
Mounting dimensions (W x H x D) in mm			
• Direct-on-line starters and reversing starters	mm	110 x 230 x 170	110 x 230 x 150
Permissible ambient temperature			
• During operation	°C	-25 ... +55	
• During storage	°C	-40 ... +70	
Permissible mounting position		Any	
Vibration resistance acc. to IEC 60068, parts 2-6		2 g	
Shock resistance acc. to IEC 60068, parts 2-27		Half-wave 15 g/11 ms	
Current consumption			
• From auxiliary circuit L+/M (U1)	mA	approx. 20	
• From auxiliary circuit A1/A2 (U2)		--	
Rated operational current for power bus I_e	A	25	
Rated operational voltage U_e	V	400 (50/60 Hz)	
Approval DIN VDE 0106, part 101	V	Up to 500	
CSA and UL approval	V	Up to 600	
Conductor cross-sections			
Incoming energy supply	mm ²	max. 6 x 4	
Degree of protection		IP65	
Touch protection		Safe from finger-touch	
Degree of pollution		3, IEC 60664 (IEC 61131)	
Rated impulse withstand voltage U_{imp}	kV	6	
Rated insulation voltage U_i	V	400	
Rated operational current for starters I_e			
• AC-1/2/3 at 40 °C			
- At 400 V	A	16	25
- At 500 V	A	16	25
Rated short-circuit breaking capacity	kA	50 at 400 V	
Type of coordination according to IEC 60947-4-1		2	
Protective separation between main and auxiliary circuits	V	400, according to DIN VDE 0106, part 101	
Operating times at 0.85 ... 1.1 x U_e			
• Closing delay	ms	--	25 ... 100
• Opening delay	ms	--	7 ... 10
Device functions			
• Group diagnostics		Yes, parameterizable	
Device displays			
• Group error		SF LED (red)	

SIMATIC ET 200 distributed I/O

ET 200pro

ET 200pro Safety motor starter Solutions local/PROFIsafe – Safety local modules

Selection and ordering data

Version	Order No.
Safety local modules	
 <p>3RK1 304-0HS00-7AA0</p>	<p>Safety local isolator module¹⁾²⁾ Rated operational current 16 A</p> <p>3RK1 304-0HS00-7AA0</p>
 <p>3RK1 304-0HS00-8AA0</p>	<p>400 V disconnecting module³⁾⁴⁾ Rated operational current 25 A</p> <p>3RK1 304-0HS00-8AA0</p>

- 1) The Safety local isolator module only functions when used together with the 400 V disconnecting module.
- 2) Only in combination with the special backplane bus module for the Safety local isolator module (see page 9/310 "Accessories for ET 200pro motor starters").
- 3) The 400 V disconnecting module only functions when used together with the Safety local isolator module or with the F-Switch.
- 4) The 400 V disconnecting module only functions when used together with the backplane bus module and the wide module rack. The backplane bus module and the wide module rack must be ordered separately (see page 9/310 "Accessories for ET 200pro motor starters").

Overview

Safety Solution PROFIsafe

With the Safety PROFIsafe modules

- F-Switch and
 - 400 V disconnecting module
- safety levels SIL 3 (according to IEC 62061) and PL e (according to ISO 13849-1) can be achieved with an appropriate connection.

F-Switch PROFIsafe

Fail-safe digital inputs/outputs in degrees of protection IP65 to IP67 for cabinet-free use close to the machine.

Fail-safe digital inputs

- For the fail-safe reading in of sensor information (1-/2-channel)
- Including integrated discrepancy evaluation for 2v2 signals
- Internal sensor supplies (incl. testing) available

Fail-safe digital outputs

- 3 fail-safe PP-switching outputs for safe switching of the backplane busbars

The F-Switch is certified up to SIL 3 / PL e and has detailed diagnostics.

It supports PROFIsafe in PROFIBUS configurations as well as in PROFINET configurations.

Note:

Safety characteristics see IC 10 · 2013, Chapter 16 "Appendix" → "Standards and Approvals" → "Overview".



400 V disconnecting module

See "Safety local modules", Overview page 9/302 and Technical specifications page 9/303.

Functionality

The PROFIsafe F-Switch is a fail-safe electronic module for PROFIsafe safety applications. It has two fail-safe inputs and outputs for safe switching of the 24 V supply over backplane busbars. In combination with the 400 V disconnecting module, the fail-safe disconnection of ET 200pro motor starters is possible in PROFIsafe applications up to SIL 3 / PL e.

Selection and ordering data

Version	Order No.
ET 200pro Safety modules	
 3RK1 304-0HS00-8AA0	400 V disconnecting module¹⁾²⁾ Rated operational current 25 A 3RK1 304-0HS00-8AA0
 6ES7 148-1FS00-0AB0	F-Switch PROFIsafe 24 V DC, including bus module Connection module to be ordered separately. 6ES7 148-4FS00-0AB0
	Connection module for F-Switch 24 V DC 6ES7 194-4DA00-0AA0

¹⁾ The 400 V disconnecting module only functions when used together with the Safety local isolator module or with the F-Switch.

²⁾ The 400 V disconnecting module only functions when used together with the backplane bus module and the wide module rack. The backplane bus module and the wide module rack must be ordered separately (see page 9/310 "Accessories for ET 200pro motor starters").

SIMATIC ET 200 distributed I/O

ET 200pro

Accessories for ET 200pro motor starters

Overview

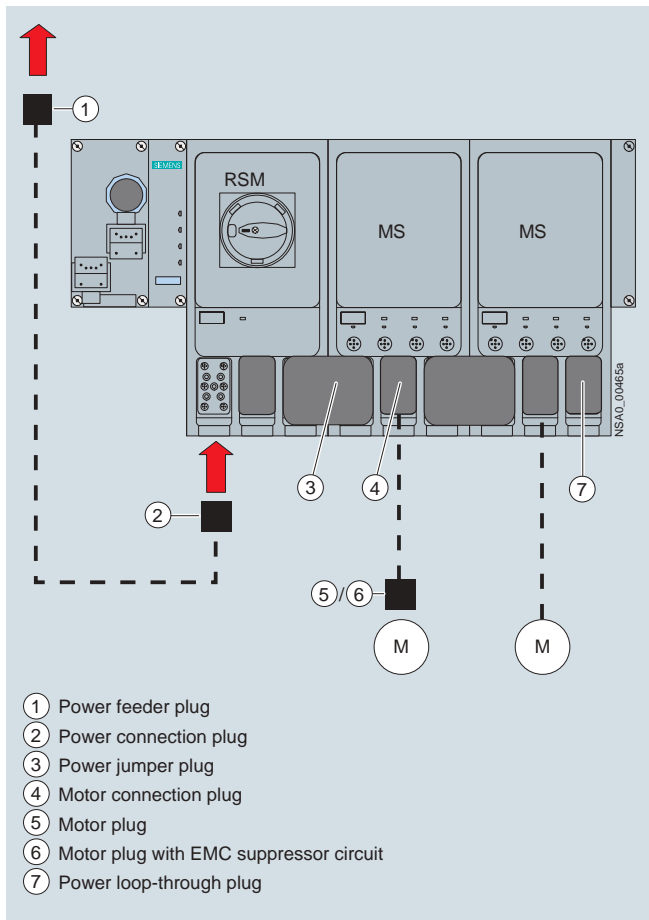

Basic structure of an ET 200pro version with (from the left) connection module for IM, interface module for communication (IM), RSM isolator module, two ET 200pro motor starters (MS), and connections for energy

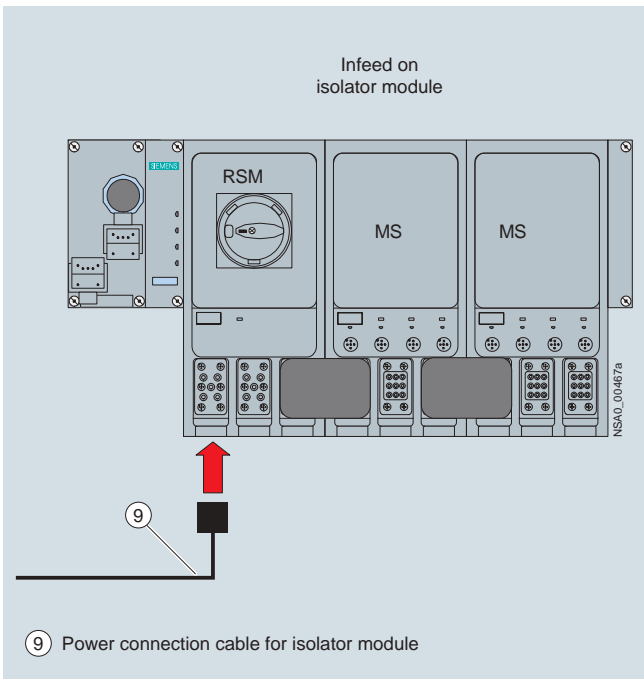

Infeed on the RSM isolator module

- Legend:**
- ① Power feeder plug (see page 9/308)
 - ② Power connection plug (see page 9/308)
 - ③ Power jumper plug (see page 9/308)
 - ④ Motor connection plug (see page 9/308)
 - ⑤ Motor plug (see page 9/308)
 - ⑥ Motor plug with EMC suppressor circuit (see page 9/308)
 - ⑦ Power loop-through plug (see page 9/308)
 - ⑧ Power connection cable (see page 9/308)
 - ⑨ Power connection cable for isolator module (see page 9/308)
 - ⑩ Motor cable (see page 9/309)

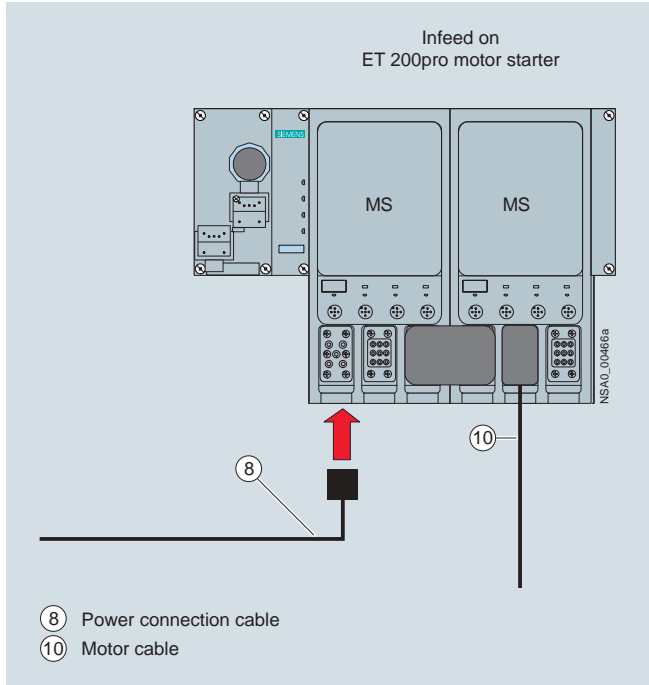

Infeed on the ET 200pro motor starter

9

Power bus

The power supply to the field devices (ET 200pro motor starters, M200D motor starters) is provided via the power bus, in which the power T terminal connectors or power double-T terminal connectors are connected by power bus cables.

Feeders

From the terminal connectors, spur lines with Han Q4/2 plugs lead to the field devices, from which the motors are supplied with power via motor connection cables.

Interruption-free thanks to power terminal connectors

In finger-safe connection technology, the power T clamp connectors and power TT clamp connectors connect the components of a feeder to the power bus. They ensure interruption-free operation, i. e. when the components are plugged in the power bus is not interrupted.

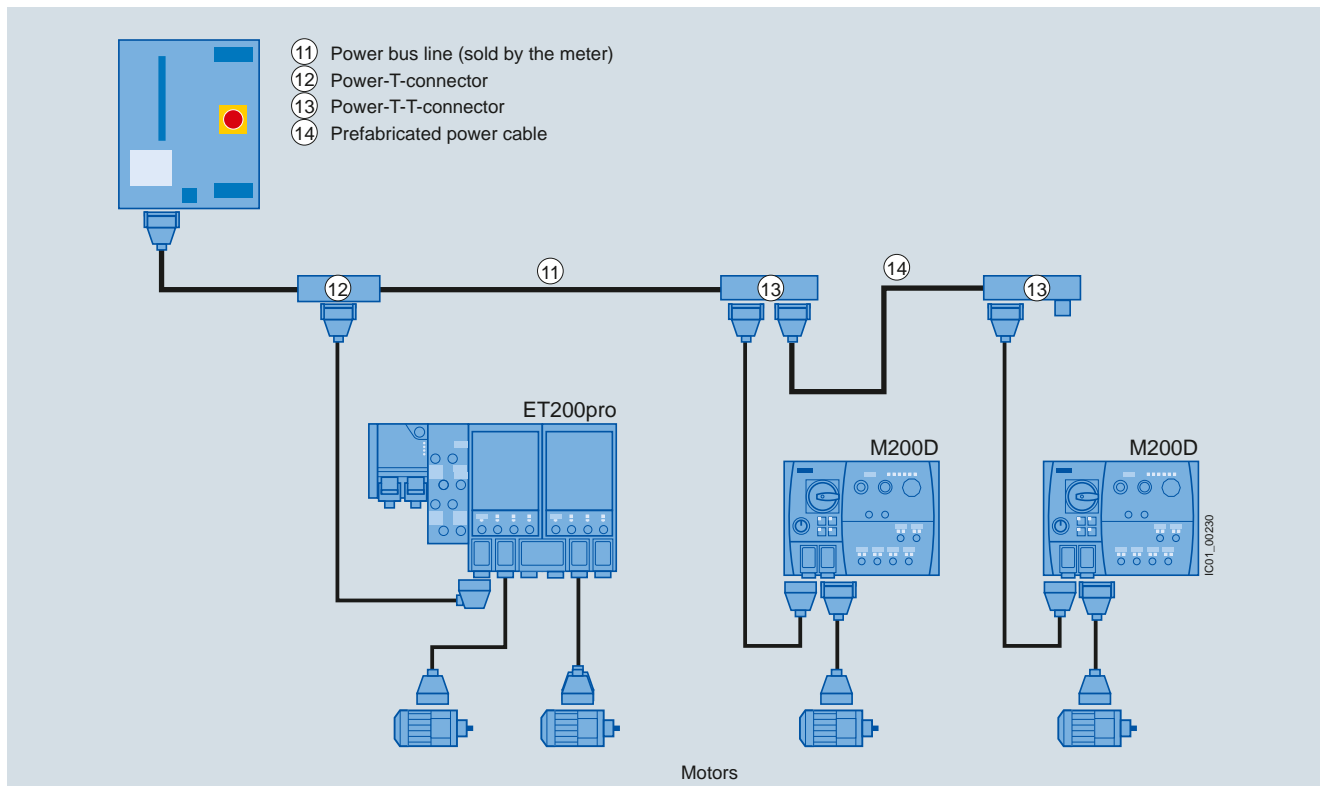

Power supply to the motors via the power bus with power T and TT clamp connectors linked by power bus cables, spur lines to the field devices (motor starters), and power loop-through to the motors via motor connection cables

Motor control via PROFIBUS

The interface modules (IM) for PROFIBUS can be combined with three different connection modules for connecting PROFIBUS DP and the power supply:

- Direct connection with cable glands
- ECOFAST connection with hybrid fieldbus cables (with two copper cores for data transfer with PROFIBUS DP, and four copper cores for the power supply), and ECOFAST connectors (HanBrid)
- M12, 7/8" connection
 - with M12 connecting cable and M12 plugs for data transfer with PROFIBUS DP
 - with 7/8" connecting cable and 7/8" plugs for the power supply

The connection modules with the relevant accessories can be found among the accessories for the ET 200pro interface modules IM 154-1 and IM 154-2.

Motor control via PROFINET

The connection modules with the relevant accessories can be found among the accessories for the ET 200pro interface module IM 154-4 PN.

Motor control via Industrial Wireless LAN

As well as wired solutions, communication can also be made via Industrial Wireless LAN (see interface module IM 154-6 PN IWLAN).



SIMATIC ET 200 distributed I/O

ET 200pro

Accessories for ET 200pro motor starters

Selection and ordering data

Version	Order No.
Incoming energy supply	
① Power feeder plug Connector set for energy supply, e.g. for connecting to T clamp connectors, comprising a coupling enclosure, straight outgoing feeder (with bracket), pin insert for HAN Q4/2, incl. gland <ul style="list-style-type: none"> • 5 male contacts 2.5 mm² • 5 male contacts 4 mm² • 5 male contacts 6 mm² 	3RK1 911-2BS60 3RK1 911-2BS20 3RK1 911-2BS40
② Power connection plugs Connector set for energy supply for connection to ET 200pro motor starter/ ET 200pro isolator module, comprising a cable-end connector hood, angled outgoing feeder, female insert for HAN Q4/2, incl. gland <ul style="list-style-type: none"> • 5 socket contacts 2.5 mm² • 5 socket contacts 4 mm² • 5 socket contacts 6 mm² 	3RK1 911-2BE50 3RK1 911-2BE10 3RK1 911-2BE30
④ Power connection cable, assembled at one end Power connection cable for ET 200pro motor starters, open at one end, for HAN Q4/2, angled, insert turned at isolator module end, 4 x 4 mm ² <ul style="list-style-type: none"> • Length 1.5 m • Length 5.0 m 	3RK1 911-0DB13 3RK1 911-0DB33
⑤ Power connection cable for isolator module, assembled at one end Power connection cable for ET 200pro isolator modules, open at one end, for HAN Q4/2, angled, insert turned at isolator module end, 4 x 4 mm ² <ul style="list-style-type: none"> • Length 1.5 m • Length 5.0 m 	3RK1 911-0DF13 3RK1 911-0DF33
Power loop-through on the field device	
③ Power jumper plug	3RK1 922-2BQ00
⑦ Power loop-through plug Connector set for power loop-through for connection to ET 200pro motor starters/ ET 200pro isolator module, comprising a cable-end connector hood, angled outgoing feeder, pin insert for HAN Q4/2, incl. gland <ul style="list-style-type: none"> • 4 male contacts 2.5 mm² • 4 male contacts 4 mm² 	3RK1 911-2BF50 3RK1 911-2BF10
Motor cable	
④ Motor connection plug Connector set for motor cable for connection to ET 200pro motor starters, comprising a cable-end connector hood, angular outgoing feeder, pin insert for HAN Q8/0, incl. gland <ul style="list-style-type: none"> • 8 male contacts 1.5 mm² • 6 male contacts 2.5 mm² 	3RK1 902-0CE00 3RK1 902-0CC00
⑤ Motor plug Connector set for motor cable for connection to motors, comprising a cable-end connector hood, straight outgoing feeder, female insert for HAN 10e, incl. star jumper, incl. gland <ul style="list-style-type: none"> • 7 socket contacts 1.5 mm² • 7 socket contacts 2.5 mm² 	3RK1 911-2BM21 3RK1 911-2BM22
⑥ Motor plugs with EMC suppressor circuit Connector set for motor cable for connection to motors, comprising a cable-end connector hood, straight outgoing feeder, female insert for HAN 10e with EMC suppressor circuit, incl. star jumper, incl. gland <ul style="list-style-type: none"> • 7 socket contacts 1.5 mm² • 7 socket contacts 2.5 mm² 	3RK1 911-2BL21 3RK1 911-2BL22



Version	Order No.
Motor cable (continued)	
<p>⑩ Motor cable, assembled at one end Open at one end, HAN Q8, angled, length 5 m</p> <ul style="list-style-type: none"> • Motor cable for motor without brake, for ET 200pro, 4 x 1.5 mm² • Motor cable for motor with brake for ET 200pro, 6 x 1.5 mm² 	<p>3RK1 911-0EB31</p> <p>3RK1 911-0ED31</p>
Power bus	
<p>⑫ Power T clamp connectors For 400 V AC, for connection of feeders (e.g. motor starters) by means of standard round cable at any point of the power bus, by insulation displacement connection, used with pre-assembled bus segments</p> <ul style="list-style-type: none"> • 2.5 mm² / 4 mm² • 4 mm² / 6 mm² 	<p>3RK1 911-2BF01</p> <p>3RK1 911-2BF02</p>
<p>⑬ Power double-T clamp connectors For 400 V AC, for connection of feeders (e.g. motor starters) by means of standard round cable at any point of the power bus, by insulation displacement connection, used with pre-assembled bus segments, connection of two motor starters possible</p> <ul style="list-style-type: none"> • 4 mm² / 6 mm² 	<p>3RK1 911-2BG02</p>
<p>Sealing set (comprising 2 seals) For power T / power double T clamp connector</p> <ul style="list-style-type: none"> • For power cables with Ø 10 ... 13 mm • For power cables with Ø 13 ... 16 mm • For power cables with Ø 16 ... 19 mm • For power cables with Ø 19 ... 22 mm • Blanking plug 	<p>3RK1 911-5BA00</p> <p>3RK1 911-5BA10</p> <p>3RK1 911-5BA20</p> <p>3RK1 911-5BA30</p> <p>3RK1 911-5BA50</p>
<p>Selection module for 400 V AC, 50 Hz, for selective shutdown of feeders on the power bus, with lockable repair switch, for line protection on cross sectional transitions on the power bus, for increasing the size of the power bus segments, with feedback contact via M12 plug, generally with 6 mm² wiring</p> <p>Connected load for rated current:</p> <ul style="list-style-type: none"> • 8 A • 16 A • 25 A 	<p>3RK1 911-4AB08</p> <p>3RK1 911-4AB16</p> <p>3RK1 911-4AB25</p>
 <p>3RK1 911-4AB16</p>	
Other accessories for power connection system	
 <p>3RK1 902-0AH00</p>	<p>Crimping tool suitable for D and E contacts (male and female contacts)</p> <ul style="list-style-type: none"> • HAN D contact: 0.5 ... 1.5 mm² for HAN Q4/2 • HAN E contact: 0.5 ... 2.5 mm² for HAN 8/0
 <p>3RK1 902-0CW00</p>	<p>Crimping tools for male/female contacts 4 mm² and 6 mm²</p>
	<p>Disassembly tool</p> <ul style="list-style-type: none"> • For male and female contacts for 9-pole HAN Q4/2 inserts • For male and female contacts for 9-pole inserts (e.g. HAN Q8)
	<p>Sealing cap for power socket connectors</p> <ul style="list-style-type: none"> • 1 unit per pack • Ten units per pack
	<p>3RK1 902-0AB00</p> <p>3RK1 902-0AJ00</p> <p>3RK1 902-0CK00</p> <p>3RK1 902-0CJ00</p>

More connection technology products can be found at our "Siemens Solution Partners Automation" under "Distributed Field Installation System" technology:
www.siemens.com/automation/partnerfinder

SIMATIC ET 200 distributed I/O

ET 200pro

Accessories for ET 200pro motor starters

Version	Order No.
Further accessories	
Module racks, wide¹⁾ <ul style="list-style-type: none"> • Length 500 mm • Length 1 000 mm • Length 2 000 mm 	6ES7 194-4GB00-0AA0 6ES7 194-4GB60-0AA0 6ES7 194-4GB20-0AA0
Module racks, wide, compact¹⁾ <ul style="list-style-type: none"> • Length 500 mm • Length 1 000 mm • Length 2 000 mm 	6ES7 194-4GD00-0AA0 6ES7 194-4GD10-0AA0 6ES7 194-4GD20-0AA0
Backplane bus modules 110 mm²⁾	3RK1 922-2BA00
Backplane bus modules for Safety local isolator modules	3RK1 922-2BA01
Hand-held devices for ET 200pro motor starters (or for ET 200S High Feature and M200D motor starters) for local operation. The motor-starter-specific serial interface cables must be ordered separately. The RS 232 interface cable 3RK1 922-2BP00 is used for the MS ET 200pro.	3RK1 922-3BA00
 3RK1 922-3BA00	RS 232 interface cable Serial data connection between ET 200pro (or M200D) motor starters and the RS232 interface of a PC/PG/laptop (with the Motor Starter ES software) or the hand-held device 3RK1 922-3BA00.
	3RK1 922-2BP00
USB interface cable, 2.5 m Serial data connection between ET 200pro (or M200D) motor starters and the USB interface of a PC/PG/laptop (with the Motor Starter ES software).	6SL3 555-0PA00-2AA0
 3RK1 901-1KA00	Sealing cap M12 For sealing unused M12 input and output sockets (one set contains 10 sealing caps)
	3RK1 901-1KA00
Documentation	
Manual³⁾ SIMATIC ET 200pro Motor Starters <ul style="list-style-type: none"> • German • English • French 	

¹⁾ The wide module rack can accommodate all ET 200pro motor starters and any optional modules (isolator module, Safety local isolator module and 400 V disconnecting module).

²⁾ The backplane bus module is a prerequisite for operation of the ET 200pro motor starters and the optional modules.

³⁾ <http://support.automation.siemens.com/WWW/view/en/22332388>

Overview

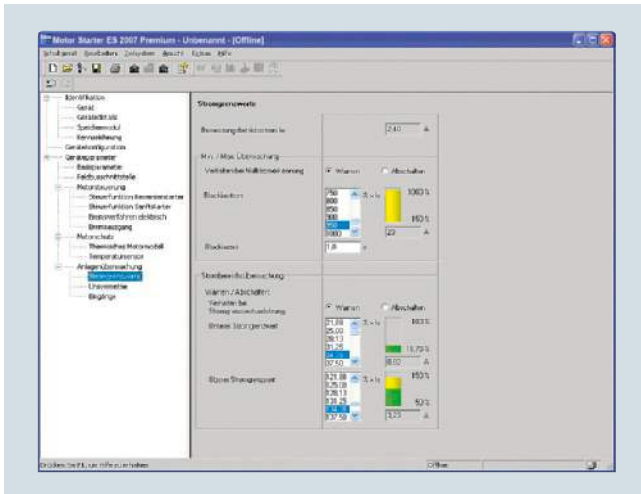

Motor Starter ES for parameterization, monitoring, diagnostics and testing of motor starters

Motor Starter ES is used for commissioning, parameterization, diagnostics, documentation, and the preventative maintenance of the motor starters in the SIMATIC ET 200S, ET 200pro, ECOFAST, and M200D product families.

Note:

For more information, see page 9/180 to 9/183.

SIMATIC ET 200 distributed I/O

ET 200eco PN

ET 200eco PN

Overview



- Compact block I/O for processing digital, analog and IO-Link signals for connecting to the PROFINET bus system
- Cabinet-free design with degree of protection IP65/66/67 with M12 connections
- Very rugged and resistant metal enclosure and encapsulated

- Compact module in two types of enclosures:
 - 30 mm x 200 mm x 37 mm (W x H x D, long and narrow enclosure), with 4 x M12 for digital signals
 - 60 mm x 175 mm x 37 mm (W x H x D, short and wide enclosure), with 8 x M12 for digital signals and IO-Link
 - 60 mm x 175 mm x 37 mm (W x H x D, short and wide enclosure) with 4 x M12 or 8 x M12 for analog signals
- PROFINET connection: 2 x M12 and automatic PROFINET address assignment
- Data transmission rate 100 Mbit/s
- LLDP proximity detection without PG and Fast Startup (boot up within approx 0.5 seconds)
- Supply and load voltage connection: 2 x M12
- Module variance:
 - 8 DI
 - 16 DI
 - 8 DO (2 A)
 - 8 DO (1.3 A)
 - 8 DO (0.5 A)
 - 16 DO (1.3 A)
 - 8 DI/DO (1.3 A),
 - 8 AI (U, I, TC, RTD)
 - 8 AI (TC, RTD)
 - 4 AO (U, I)
 - 4 IO-Link + 8 DI + 4 DO (1.3 A)
- Channel-specific diagnostics
- Ambient temperature range -40 °C to 60 °C

Technical specifications

	6ES7 141-6BF00-0AB0	6ES7 141-6BG00-0AB0	6ES7 141-6BH00-0AB0
General information			
Vendor identification (VendorID)	002AH	002AH	002AH
Device identifier (DeviceID)	0306H	0306H	0306H
Supply voltage			
24 V DC	Yes	Yes	Yes
permissible range, lower limit (DC)	20.4 V	20.4 V	20.4 V
permissible range, upper limit (DC)	28.8 V	28.8 V	28.8 V
Reverse polarity protection	Yes	Yes	Yes
Input current			
Current consumption, typ.	100 mA	100 mA	100 mA
Encoder supply			
Number of outputs	4	8	8
Output current, rated value	100 mA; per output	100 mA; per output	100 mA; per output
24 V encoder supply			
• Short-circuit protection	Yes	Yes	Yes
Power losses			
Power loss, typ.	5.5 W	4.5 W	6.5 W
Digital inputs			
Number/binary inputs	8	8	16
• In groups of	2	1	2
Input characteristic curve acc. to IEC 61131, Type 3	Yes	Yes	Yes
Number of simultaneously controllable inputs			
• all mounting positions			
- up to 60 °C, max.	8	8	16
Input voltage			
• Type of input voltage	DC	DC	DC
• Rated value, DC	24 V	24 V	24 V
• for signal "0"	-3 to +5 V	-3 to +5 V	-3 to +5 V
• for signal "1"	11 to 30 V	11 to 30 V	11 to 30 V

Technical specifications (continued)

	6ES7 141-6BF00-0AB0	6ES7 141-6BG00-0AB0	6ES7 141-6BH00-0AB0
Input current			
• for signal "0", max. (permissible quiescent current)	1.5 mA	1.5 mA	1.5 mA
• for signal "1", typ.	7 mA	7 mA	7 mA
Input delay (for rated value of input voltage)			
• for standard inputs			
- at "0" to "1", max.	typically 3 ms	typically 3 ms	typically 3 ms
- at "1" to "0", max.	typically 3 ms	typically 3 ms	typically 3 ms
Cable length			
• Cable length unshielded, max.	30 m	30 m	30 m
Interfaces			
Transmission procedure	100BASE-TX	100BASE-TX	100BASE-TX
Transmission rate, max.	100 Mbit/s	100 Mbit/s	100 Mbit/s
Supports protocol for PROFINET IO			
• Number of PROFINET interfaces	2	2	2
• Autocrossing	Yes	Yes	Yes
• Automatic detection of transmission speed	Yes	Yes	Yes
• Integrated switch	Yes	Yes	Yes
• PROFINET IO Device			
- IRT with the option "high flexibility" supported	Yes	Yes	Yes
- Prioritized startup supported	Yes	Yes	Yes
Protocols			
Supports protocol for PROFINET IO	Yes	Yes	Yes
PROFINET CBA	No	No	No
Protocols (Ethernet)			
• SNMP	Yes	Yes	Yes
• DCP	Yes	Yes	Yes
• LLDP	Yes	Yes	Yes
• ping	Yes	Yes	Yes
• arp	Yes	Yes	Yes
Interrupts/diagnostics/ status information			
Status indicator	Yes; Green LED	Yes; Green LED	Yes; Green LED
Alarms			
• Diagnostic alarm	Yes	Yes	Yes
Diagnostic messages			
• Diagnostic functions	Yes	Yes	Yes
• Diagnostic information readable	Yes	Yes	Yes
• Monitoring the supply voltage	Yes; Green "ON" LED	Yes; Green "ON" LED	Yes; Green "ON" LED
• Wire break in signal transmitter cable	Yes	Yes	Yes
• Short circuit encoder supply	Yes; Per channel group	Yes; Per channel group	Yes; Per channel group
• Group error	Yes; Red/yellow "SF/MT" LED	Yes; Red/yellow "SF/MT" LED	Yes; Red/yellow "SF/MT" LED
Galvanic isolation			
between the load voltages	Yes	Yes	Yes
between load voltage and all other switching components	No	No	No
between Ethernet and electronics	Yes	Yes	Yes
Galvanic isolation digital inputs			
• between the channels	No	No	No
Permissible potential difference			
between different circuits	75 VDC / 60 VAC	75 VDC / 60 VAC	75 VDC / 60 VAC
Isolation			
tested with			
• 24 V DC circuits	500 V	500 V	500 V
• Interface	1 500 V; According to IEEE 802.3	1 500 V; According to IEEE 802.3	1 500 V; According to IEEE 802.3
Degree and class of protection			
IP65	Yes	Yes	Yes
IP66	Yes	Yes	Yes
IP67	Yes	Yes	Yes

SIMATIC ET 200 distributed I/O

ET 200eco PN

ET 200eco PN

Technical specifications (continued)

	6ES7 141-6BF00-0AB0	6ES7 141-6BG00-0AB0	6ES7 141-6BH00-0AB0
Connection method			
M12	Yes	Yes	Yes
Dimensions			
Width	30 mm	60 mm	60 mm
Height	200 mm	175 mm	175 mm
Depth	49 mm	49 mm	49 mm
Weight			
Weight	550 g	910 g	910 g

	6ES7 142-6BF50-0AB0	6ES7 142-6BF00-0AB0	6ES7 142-6BG00-0AB0	6ES7 142-6BR00-0AB0	6ES7 142-6BH00-0AB0
General information					
Vendor identification (VendorID)	002AH	002AH	002AH	002AH	002AH
Device identifier (DeviceID)	0306H	0306H	0306H	0306H	0306H
Supply voltage					
Load voltage 1L+					
• Rated value (DC)	24 V	24 V	24 V	24 V	24 V
• permissible range, lower limit (DC)	20.4 V	20.4 V	20.4 V	20.4 V	20.4 V
• permissible range, upper limit (DC)	28.8 V	28.8 V	28.8 V	28.8 V	28.8 V
• Reverse polarity protection	Yes	Yes	Yes	Yes	Yes
Load voltage 2L+					
• Rated value (DC)	24 V	24 V	24 V	24 V	24 V
• permissible range, lower limit (DC)	20.4 V	20.4 V	20.4 V	20.4 V	20.4 V
• permissible range, upper limit (DC)	28.8 V	28.8 V	28.8 V	28.8 V	28.8 V
• Reverse polarity protection	Yes	Yes	Yes	Yes	Yes
Input current					
from load voltage 1L+ (unswitched voltage)	100 mA	4 A	4 A	4 A	4 A
from load voltage 2L+, max.	4 A	4 A	4 A	4 A	4 A
Power losses					
Power loss, typ.	3 W	5.5 W	5.5 W	5 W	5.5 W
Digital outputs					
Number/binary outputs	8	8	8	8	16
• In groups of	8	4	4	4	8
Functionality/short-circuit strength	Yes; Electronic	Yes; Electronic	Yes; Electronic	Yes; Electronic	Yes; Electronic
• Response threshold, typ.	0.7 A	1.8 A	1.8 A	2.8 A	1.8 A
Limitation of inductive shutdown voltage to	Typ. (L1+, L2+) -47 V	Typ. (L1+, L2+) -47 V	Typ. (L1+, L2+) -47 V	Typ. (L1+, L2+) -47 V	Typ. (L1+, L2+) -47 V
Controlling a digital input	Yes	Yes	Yes	Yes	Yes
Switching capacity of the outputs					
• on lamp load, max.	5 W	5 W	5 W	10 W	5 W
Output current					
• for signal "1" rated value	0.5 A	1.3 A; Maximum	1.3 A; Maximum	2 A	1.3 A; Maximum
• for signal "0" residual current, max.	1.5 mA	1.5 mA	1.5 mA	1.5 mA	1.5 mA
Parallel switching of 2 outputs					
• for increased power	No	No	No	No	No
• for redundant control of a load	Yes	Yes	Yes	Yes	Yes
Switching frequency					
• with resistive load, max.	100 Hz	100 Hz	100 Hz	100 Hz	100 Hz
• with inductive load, max.	0.5 Hz	0.5 Hz	0.5 Hz	0.5 Hz	0.5 Hz
• on lamp load, max.	1 Hz	1 Hz	1 Hz	1 Hz	1 Hz
Aggregate current of outputs (per group)					
• all mounting positions					
- up to 55 °C, max.		3.9 A			
- up to 60 °C, max.	4 A	2.6 A	3.9 A	3.9 A	3.9 A
Cable length					
• Cable length unshielded, max.	30 m	30 m	30 m	30 m	30 m

Technical specifications (continued)

	6ES7 142-6BF50-0AB0	6ES7 142-6BF00-0AB0	6ES7 142-6BG00-0AB0	6ES7 142-6BR00-0AB0	6ES7 142-6BH00-0AB0
Interfaces					
Transmission procedure	100BASE-TX	100BASE-TX	100BASE-TX	100BASE-TX	100BASE-TX
Transmission rate, max.	100 Mbit/s	100 Mbit/s	100 Mbit/s	100 Mbit/s	100 Mbit/s
Supports protocol for PROFINET IO					
• Number of PROFINET interfaces	2	2	2	2	2
• Autocrossing	Yes	Yes	Yes	Yes	Yes
• Automatic detection of transmission speed	Yes	Yes	Yes	Yes	Yes
• Integrated switch	Yes	Yes	Yes	Yes	Yes
• PROFINET IO Device					
- IRT with the option "high flexibility" supported	Yes	Yes	Yes	Yes	Yes
- Prioritized startup supported	Yes	Yes	Yes	Yes	Yes
Protocols					
Supports protocol for PROFINET IO	Yes	Yes	Yes	Yes	Yes
PROFINET CBA	No	No	No	No	No
Protocols (Ethernet)					
• SNMP	Yes	Yes	Yes	Yes	Yes
• DCP	Yes	Yes	Yes	Yes	Yes
• LLDP	Yes	Yes	Yes	Yes	Yes
• ping	Yes	Yes	Yes	Yes	Yes
• arp	Yes	Yes	Yes	Yes	Yes
Interrupts/diagnostics/status information					
Status indicator	Yes; Green LED	Yes; Green LED	Yes; Green LED	Yes; Green LED	Yes; Green LED
Alarms					
• Diagnostic alarm	Yes	Yes	Yes	Yes	Yes
Diagnostic messages					
• Diagnostic functions	Yes	Yes	Yes	Yes	Yes
• Diagnostic information readable	Yes	Yes	Yes	Yes	Yes
• Monitoring the supply voltage	Yes; Green "ON" LED	Yes; Green "ON" LED	Yes; Green "ON" LED	Yes; Green "ON" LED	Yes; Green "ON" LED
• Wire break in actuator cable	Yes	Yes	Yes	Yes	Yes
• Short circuit	Yes	Yes	Yes	Yes	Yes
• Group error	Yes; Red/yellow "SF/MT" LED	Yes; Red/yellow "SF/MT" LED	Yes; Red/yellow "SF/MT" LED	Yes; Red/yellow "SF/MT" LED	Yes; Red/yellow "SF/MT" LED
Galvanic isolation					
between the load voltages	Yes	Yes	Yes	Yes	Yes
between load voltage and all other switching components	No	No	No	No	No
between Ethernet and electronics	Yes	Yes	Yes	Yes	Yes
Galvanic isolation digital outputs					
• between the channels	No	No	No	No	No
Permissible potential difference					
between different circuits	75 VDC / 60 VAC	75 VDC / 60 VAC	75 VDC / 60 VAC	75 VDC / 60 VAC	75 VDC / 60 VAC
Isolation					
tested with					
• 24 V DC circuits	500 V	500 V	500 V	500 V	500 V
• Interface	1 500 V; According to IEEE 802.3	1 500 V; According to IEEE 802.3	1 500 V; According to IEEE 802.3	1 500 V; According to IEEE 802.3	1 500 V; According to IEEE 802.3
Degree and class of protection					
IP65	Yes	Yes	Yes	Yes	Yes
IP66	Yes	Yes	Yes	Yes	Yes
IP67	Yes	Yes	Yes	Yes	Yes
Connection method					
M12	Yes	Yes	Yes	Yes	Yes
Dimensions					
Width	30 mm	30 mm	60 mm	60 mm	60 mm
Height	200 mm	200 mm	175 mm	175 mm	175 mm
Depth	49 mm	49 mm	49 mm	49 mm	49 mm
Weight					
Weight	550 g	550 g	910 g	910 g	910 g

SIMATIC ET 200 distributed I/O

ET 200eco PN

ET 200eco PN

Technical specifications (continued)

6ES7 147-6BG00-0AB0	
General information	
Vendor identification (VendorID)	002AH
Device identifier (DeviceID)	0306H
Supply voltage	
24 V DC	Yes
permissible range, lower limit (DC)	20.4 V
permissible range, upper limit (DC)	28.8 V
Reverse polarity protection	Yes
Load voltage 2L+	
• Rated value (DC)	24 V
• permissible range, lower limit (DC)	20.4 V
• permissible range, upper limit (DC)	28.8 V
• Reverse polarity protection	Yes
Input current	
from load voltage 1L+ (unswitched voltage)	4 A
from load voltage 2L+, max.	4 A
Encoder supply	
Number of outputs	8
Output current, rated value	100 mA; per output
24 V encoder supply	
• Short-circuit protection	Yes
Power losses	
Power loss, typ.	6.5 W
Digital inputs	
Number/binary inputs	8
• In groups of	4
Input characteristic curve acc. to IEC 61131, Type 3	Yes
Number of simultaneously controllable inputs	
• all mounting positions	
- up to 60 °C, max.	8
Input voltage	
• Rated value, DC	24 V
• for signal "0"	-3 to +5 V
• for signal "1"	11 to 30 V
Input current	
• for signal "0", max. (permissible quiescent current)	1.5 mA
• for signal "1", typ.	7 mA
Input delay (for rated value of input voltage)	
• for standard inputs	
- at "0" to "1", max.	typically 3 ms
- at "1" to "0", max.	typically 3 ms
Cable length	
• Cable length unshielded, max.	30 m
Digital outputs	
Number/binary outputs	8
• In groups of	4
Functionality/short-circuit strength	Yes; Electronic
• Response threshold, typ.	1.8 A
Limitation of inductive shutdown voltage to	Typ. (L1+, L2+) -47 V
Controlling a digital input	Yes
Switching capacity of the outputs	
• on lamp load, max.	5 W

6ES7 147-6BG00-0AB0	
Output current	
• for signal "1" rated value	1.3 A; Maximum
• for signal "0" residual current, max.	1.5 mA
Parallel switching of 2 outputs	
• for increased power	No
• for redundant control of a load	Yes
Switching frequency	
• with resistive load, max.	100 Hz
• with inductive load, max.	0.5 Hz
• on lamp load, max.	1 Hz
Aggregate current of outputs (per group)	
• all mounting positions	
- up to 60 °C, max.	3.9 A
Cable length	
• Cable length unshielded, max.	30 m
Interfaces	
Transmission procedure	100BASE-TX
Transmission rate, max.	100 Mbit/s
Supports protocol for PROFINET IO	
• Number of PROFINET interfaces	2
• Autocrossing	Yes
• Automatic detection of transmission speed	Yes
• Integrated switch	Yes
• PROFINET IO Device	
- IRT with the option "high flexibility" supported	Yes
- Prioritized startup supported	Yes
Protocols	
Supports protocol for PROFINET IO	Yes
Protocols (Ethernet)	
• SNMP	Yes
• DCP	Yes
• LLDP	Yes
• ping	Yes
• arp	Yes
Interrupts/diagnostics/status information	
Status indicator	Yes; Green LED
Alarms	
• Diagnostic alarm	Yes
Diagnostic messages	
• Diagnostic functions	Yes
• Diagnostic information readable	Yes
• Monitoring the supply voltage	Yes; Green "ON" LED
• Wire break in actuator cable	Yes
• Wire break in signal transmitter cable	Yes
• Short circuit	Yes
• Short circuit encoder supply	Yes
• Group error	Yes; Red/yellow "SF/MT" LED
Galvanic isolation	
between the load voltages	Yes
between load voltage and all other switching components	No
between Ethernet and electronics	Yes
Galvanic isolation digital inputs	
• between the channels	No
Galvanic isolation digital outputs	
• between the channels	No
Permissible potential difference	
between different circuits	75 VDC / 60 VAC

Technical specifications (continued)

6ES7 147-6BG00-0AB0		6ES7 147-6BG00-0AB0	
Isolation tested with		Connection method M12	Yes
• 24 V DC circuits	500 V	Dimensions Width	60 mm
• Interface	1 500 V; According to IEEE 802.3	Height	175 mm
Degree and class of protection IP65	Yes	Depth	49 mm
IP66	Yes	Weight Weight	910 g
IP67	Yes		

6ES7 144-6KD00-0AB0		6ES7 144-6KD50-0AB0	
General information Vendor identification (VendorID)	002AH		002AH
Device identifier (DeviceID)	0306H		0306H
Supply voltage 24 V DC	Yes		Yes
permissible range, lower limit (DC)	20.4 V		20.4 V
permissible range, upper limit (DC)	28.8 V		28.8 V
Reverse polarity protection	Yes		Yes; against destruction
Input current Current consumption, typ.	110 mA		110 mA
Encoder supply Number of outputs	4		
24 V encoder supply			
• Short-circuit protection	Yes; Electronic at 1.4 A		
• Output current, max.	1 A		
Power losses Power loss, typ.	2.8 W		2.8 W
Analog inputs Number of analog inputs	8		8
Number of analog inputs for voltage/ current measurement	4		
Number of analog inputs for resistance/resistance thermometer measurement	4		8
permissible input voltage for voltage input (destruction limit), max.	28.8 V permanent, 35 V for max. 500 ms		
Input ranges (rated values), voltages			
• 0 to +10 V	Yes		
• 1 to 5 V	Yes		
• -10 V to +10 V	Yes		
• -80 mV to +80 mV	Yes		Yes
Input ranges (rated values), currents			
• 0 to 20 mA	Yes		
• -20 to +20 mA	Yes		
• 4 to 20 mA	Yes		
Input ranges (rated values), thermoelements			
• Type E	Yes		Yes
• Type J	Yes		Yes
• Type K	Yes		Yes
• Type N	Yes		Yes

SIMATIC ET 200 distributed I/O

ET 200eco PN

ET 200eco PN

Technical specifications (continued)

	6ES7 144-6KD00-0AB0	6ES7 144-6KD50-0AB0
Input ranges (rated values), resistance thermometers		
• Ni 100	Yes	Yes
• Ni 1000	Yes	Yes
• Ni 120	Yes	Yes
• Ni 200	Yes	Yes
• Ni 500	Yes	Yes
• Pt 100	Yes	Yes
• Pt 1000	Yes	Yes
• Pt 200	Yes	Yes
• Pt 500	Yes	Yes
Input ranges (rated values), resistors		
• 0 to 150 ohms	Yes	Yes
• 0 to 300 ohms	Yes	Yes
• 0 to 600 ohms	Yes	Yes
• 0 to 3000 ohms	Yes	Yes
Thermocouple (TC)		
• Temperature compensation		
- Parameterizable	Yes	Yes
- internal temperature compensation	Yes	Yes
- external temperature compensation with compensations socket	Yes	Yes
- external temperature compensation with Pt100		Yes
- dynamic reference temperature value		Yes
- for definable comparison point temperature		Yes
Cable length		
• Cable length, shielded, max.	30 m	30 m
Analog value creation		
Analog value display	SIMATIC S7 format	SIMATIC S7 format
Measurement principle	integrating	integrating
Integrations and conversion time/ resolution per channel		
• Resolution (incl. overrange)	15 bits + sign	15 bits + sign
• Integration time, parameterizable	Yes	Yes
• Integration time, ms	2/16.67/20/100 ms	2/16.67/20/100 ms
• Interference voltage suppression for interference frequency f1 in Hz	500 / 60 / 50 / 10 Hz	500 / 60 / 50 / 10 Hz
• Conversion time (per channel)	4/19/22/102 ms	4/19/22/102 ms
Smoothing of measured values		
• Parameterizable	Yes	Yes
• Step: None	Yes; 1 x cycle time	Yes; 1 x cycle time
• Step: low	Yes; 4 x cycle time	Yes; 4 x cycle time
• Step: Medium	Yes; 16 x cycle time	Yes; 16 x cycle time
• Step: High	Yes; 64 x cycle time	Yes; 64 x cycle time
Encoder		
Number of connectable encoders, max.	8	8
Connection of signal encoders		
• for voltage measurement	Yes	
• for current measurement as 2-wire transducer	Yes	
• for current measurement as 4-wire transducer	Yes	
• for resistance measurement with 2-conductor connection	Yes	Yes
• for resistance measurement with 3-conductor connection	Yes	Yes
• for resistance measurement with 4-conductor connection	Yes	Yes

Technical specifications (continued)

	6ES7 144-6KD00-0AB0	6ES7 144-6KD50-0AB0
Errors/accuracies		
Linearity error (relative to input area)	+/- 0,01 %	+/- 0,01 %
Temperature error (relative to input area)	U: 0.0035%/°C; I:0.006%/°C; RTD: 0.0005%/°C; TC: 0.0035%/°C	RTD: 0.0005%/°C; TC: 0.0035%/°C
Crosstalk between the inputs, min.	85 dB	-85 dB
Repeat accuracy in settled status at 25 °C (relative to input area)	+/- 0,008 %	+/- 0,008 %
Interference voltage suppression for $f = n \times (f_1 \pm 1\%)$, $f_1 =$ interference frequency		
• Series mode interference (peak value of interference < rated value of input range), min.	46 dB	46 dB
• Common mode interference, min.	70 dB	70 dB
Interfaces		
Transmission procedure	100BASE-TX	100BASE-TX
Transmission rate, max.	100 Mbit/s	100 Mbit/s
Supports protocol for PROFINET IO		
• Number of PROFINET interfaces	2	2
• Autocrossing	Yes	Yes
• Automatic detection of transmission speed	Yes	Yes
• Integrated switch	Yes	Yes
• PROFINET IO Device		
- IRT with the option "high flexibility" supported	Yes	
- Prioritized startup supported	Yes	Yes
Protocols		
Supports protocol for PROFINET IO	Yes	Yes
PROFINET CBA	Yes	
Supports protocol for PROFI-safe	No	
Protocols (Ethernet)		
• SNMP	Yes	Yes
• DCP	Yes	Yes
• LLDP	Yes	Yes
• ping	Yes	Yes
• arp	Yes	Yes
Interrupts/diagnostics/status information		
Alarms		
• Diagnostic alarm	Yes	Yes
Diagnostic messages		
• Diagnostic functions	Yes	Yes
• Diagnostic information readable	Yes	Yes
• Monitoring the supply voltage	Yes; Green "ON" LED	Yes; Green "ON" LED
• Short circuit encoder supply	Yes; per module	
• Group error	Yes; Red/yellow "SF/MT" LED	Yes; Red/yellow "SF/MT" LED
• Overflow/underflow	Yes	Yes
Galvanic isolation		
between the load voltages	Yes	Yes
between load voltage and all other switching components	No	No
between Ethernet and electronics	Yes	Yes
Galvanic isolation analog inputs		
• between the channels	No	No
Permissible potential difference		
between inputs and MANA (UCM)	10 Vpp AC	10 Vpp AC
Isolation		
tested with		
• 24 V DC circuits	500 V	500 V
• Interface	1 500 V; According to IEEE 802.3	1 500 V; According to IEEE 802.3
Degree and class of protection		
IP65	Yes	Yes
IP66	Yes	Yes
IP67	Yes	Yes

SIMATIC ET 200 distributed I/O

ET 200eco PN

ET 200eco PN

Technical specifications (continued)

	6ES7 144-6KD00-0AB0	6ES7 144-6KD50-0AB0
Connection method		
M12	Yes	Yes
Dimensions		
Width	60 mm	60 mm
Height	175 mm	175 mm
Depth	49 mm	49 mm
Weight		
Weight	930 g	930 g

	6ES7 145-6HD00-0AB0
General information	
Vendor identification (VendorID)	002AH
Device identifier (DeviceID)	0306H
Supply voltage	
24 V DC	Yes
permissible range, lower limit (DC)	20.4 V
permissible range, upper limit (DC)	28.8 V
Reverse polarity protection	Yes
Input current	
Current consumption, typ.	280 mA
Encoder supply	
Number of outputs	4
24 V encoder supply	
• Short-circuit protection	Yes; Electronic at 1.4 A
• Output current, max.	1 A
Power losses	
Power loss, typ.	5.5 W
Analog outputs	
Number of analog outputs	4
Voltage output, short-circuit protection	Yes
Voltage output, short-circuit current, max.	30 mA
Current output, no-load voltage, max.	20 V
Output ranges, voltage	
• 0 to 10 V	Yes
• 1 to 5 V	Yes
• -10 to +10 V	Yes
Output ranges, current	
• 0 to 20 mA	Yes
• -20 to +20 mA	Yes
• 4 to 20 mA	Yes
Connection of actuators	
• for voltage output 2-conductor connection	Yes
• for current output 2-conductor connection	Yes
Load impedance (in rated range of output)	
• with voltage outputs, min.	1 k Ω
• with voltage outputs, capacitive load, max.	1 μ F
• with current outputs, max.	600 Ω
• with current outputs, inductive load, max.	1 mH

	6ES7 145-6HD00-0AB0
Destruction limits against externally applied voltages and currents	
• Voltages at the outputs towards MANA	28.8 V permanent, 35 V for max. 500 ms
Cable length	
• Cable length, shielded, max.	30 m
Analog value creation	
Analog value display	SIMATIC S7 format
Measurement principle	Resistor network
Integrations and conversion time/ resolution per channel	
• Resolution (incl. overrange)	15 bits + sign
• Conversion time (per channel)	1 ms
Settling time	
• for resistive load	2 ms
• for capacitive load	1.8 ms
• for inductive load	2 ms
Errors/accuracies	
Output ripple (based on output area, bandwidth 0 to 50 kHz)	U: ± 0.6 mVrms; I: ± 0.4 nArms
Linearity error (relative to output area)	± 0.02 %
Temperature error (relative to output area)	U: 0.001%/°C; I: 0.0025%/°C
Crosstalk between the outputs, min.	70 dB
Repeat accuracy in settled status at 25 °C (relative to output area)	± 0.008 %
Interfaces	
Transmission procedure	100BASE-TX
Transmission rate, max.	100 Mbit/s
Supports protocol for PROFINET IO	
• Number of PROFINET interfaces	2
• Autocrossing	Yes
• Automatic detection of transmission speed	Yes
• Integrated switch	Yes
• PROFINET IO Device	
- IRT with the option "high flexibility" supported	Yes
- Prioritized startup supported	Yes

Technical specifications (continued)

6ES7 145-6HD00-0AB0	
Protocols	
Supports protocol for PROFINET IO	Yes
PROFINET CBA	Yes
Supports protocol for PROFIsafe	No
Protocols (Ethernet)	
• SNMP	Yes
• DCP	Yes
• LLDP	Yes
• ping	Yes
• arp	Yes
Interrupts/diagnostics/ status information	
Status indicator	Yes
Substitute values connectable	Yes
Alarms	
• Diagnostic alarm	Yes
Diagnostic messages	
• Diagnostic functions	Yes
• Diagnostic information readable	Yes
• Monitoring the supply voltage	Yes; Green "ON" LED
• Wire break	Yes; Channel-by-channel I with current output
• Short circuit	Yes; Channel-by-channel with voltage output
• Group error	Yes; Red/yellow "SF/MT" LED

6ES7 148-6JA00-0AB0	
General information	
Vendor identification (VendorID)	002AH
Device identifier (DeviceID)	0306H
Supply voltage	
24 V DC	Yes
permissible range, lower limit (DC)	20.4 V
permissible range, upper limit (DC)	28.8 V
Reverse polarity protection	Yes
Load voltage 2L+	
• Rated value (DC)	24 V
• permissible range, lower limit (DC)	20.4 V
• permissible range, upper limit (DC)	28.8 V
• Reverse polarity protection	Yes
Input current	
from load voltage 1L+ (unswitched voltage)	4 A
from load voltage 2L+, max.	4 A
Encoder supply	
Number of outputs	6
Output current, rated value	200 mA; 100 mA per output to X5-X6
24 V encoder supply	
• Short-circuit protection	Yes
Power losses	
Power loss, typ.	8 W

6ES7 145-6HD00-0AB0	
Galvanic isolation	
between the load voltages	Yes
between load voltage and all other switching components	No
between Ethernet and electronics	Yes
Galvanic isolation analog outputs	
• between the channels	No
Permissible potential difference	
between M internally and the outputs	10 Vpp AC
Degree and class of protection	
IP65	Yes
IP66	Yes
IP67	Yes
Connection method	
M12	Yes
Dimensions	
Width	60 mm
Height	175 mm
Depth	49 mm
Weight	
Weight	930 g

6ES7 148-6JA00-0AB0	
Digital inputs	
Number/binary inputs	8
Input characteristic curve acc. to IEC 61131, Type 3	Yes
Number of simultaneously controllable inputs	
• all mounting positions - up to 60 °C, max.	8
Input voltage	
• Rated value, DC	24 V
• for signal "0"	-3 to +5 V
• for signal "1"	11 to 30 V
Input current	
• for signal "0", max. (permissible quiescent current)	1.5 mA
• for signal "1", typ.	7 mA
Input delay (for rated value of input voltage)	
• for standard inputs - at "0" to "1", max. - at "1" to "0", max.	typically 3 ms typically 3 ms
Cable length	
• Cable length unshielded, max.	30 m

SIMATIC ET 200 distributed I/O

ET 200eco PN

ET 200eco PN

Technical specifications (continued)

6ES7 148-6JA00-0AB0	
Digital outputs	
Number/binary outputs	4
Functionality/short-circuit strength	Yes; Electronic
• Response threshold, typ.	1.8 A
Limitation of inductive shutdown voltage to	Typ. (L1+, L2+) -47 V
Controlling a digital input	Yes
Switching capacity of the outputs	
• on lamp load, max.	5 W
Output current	
• for signal "1" rated value	1.3 A; Maximum
• for signal "0" residual current, max.	1.5 mA
Parallel switching of 2 outputs	
• for increased power	No
• for redundant control of a load	Yes
Switching frequency	
• with resistive load, max.	100 Hz
• with inductive load, max.	0.5 Hz
• on lamp load, max.	1 Hz
Aggregate current of outputs (per group)	
• all mounting positions	
- up to 60 °C, max.	3.9 A
Cable length	
• Cable length unshielded, max.	30 m
IO-Link	
Number of ports	4
• of which simultaneously controllable	4
Transmission rate	4.8 kBd (COM1); 38.4 kBd (COM2)
Cable length unshielded, max.	20 m
Operating modes	
• IO-Link	Yes
• DI	Yes
• DO	Yes
Connection of IO-Link devices	
• via 3-wire connection	Yes
Interfaces	
Transmission procedure	100BASE-TX
Transmission rate, max.	100 Mbit/s
Supports protocol for PROFINET IO	
• Number of PROFINET interfaces	2
• Autocrossing	Yes
• Automatic detection of transmission speed	Yes
• Integrated switch	Yes
• PROFINET IO Device	
- IRT with the option "high flexibility" supported	Yes

6ES7 148-6JA00-0AB0	
Protocols	
Supports protocol for PROFINET IO	Yes
Protocols (Ethernet)	
• SNMP	Yes
• DCP	Yes
• LLDP	Yes
• ping	Yes
• arp	Yes
Interrupts/diagnostics/status information	
Status indicator	Yes; Green LED
Alarms	
• Diagnostic alarm	Yes
Diagnostic messages	
• Diagnostic functions	Yes
• Diagnostic information readable	Yes
• Monitoring the supply voltage	Yes; Green "ON" LED
• Wire break in actuator cable	Yes
• Wire break in signal transmitter cable	Yes
• Short circuit	Yes
• Short circuit encoder supply	Yes
• Group error	Yes; Red/yellow "SF/MT" LED
Galvanic isolation	
between the load voltages	Yes
between load voltage and all other switching components	No
between Ethernet and electronics	Yes
Galvanic isolation digital inputs	
• between the channels	No
Galvanic isolation digital outputs	
• between the channels	No
Permissible potential difference	
between different circuits	75 VDC / 60 VAC
Isolation	
tested with	
• 24 V DC circuits	500 V
• Interface	1 500 V; According to IEEE 802.3
Degree and class of protection	
IP65	Yes
IP66	Yes
IP67	Yes
Connection method	
M12	Yes
Dimensions	
Width	60 mm
Height	175 mm
Depth	49 mm
Weight	
Weight	910 g

Ordering data	Order No.	Order No.																		
ET 200eco PN digital input module <ul style="list-style-type: none"> • 8 DI 24 V DC; 4 x M12, dual assignment, degree of protection IP67 • 8 DI 24 V DC; 8 x M12, degree of protection IP67 • 16 DI 24 V DC; 8 x M12, dual assignment, degree of protection IP67 	6ES7 141-6BF00-0AB0 6ES7 141-6BG00-0AB0 6ES7 141-6BH00-0AB0	PROFINET M12 connector, for user assembly IE FC M12 connector PRO, for user assembly <ul style="list-style-type: none"> • 1 unit • 8 units 																		
ET 200eco PN digital output module <ul style="list-style-type: none"> • 8 DO 24 V DC/0.5 A; 4 x M12, dual assignment, 1 load voltage supply DO; degree of protection IP67 • 8 DO 24 V DC/1.3 A; 4 x M12, dual assignment, degree of protection IP67 • 8 DO 24 V DC/1.3 A; 8 x M12, degree of protection IP67 • 8 DO 24 V DC/2 A; 8 x M12, degree of protection IP67 • 16 DO 24 V DC/1.3 A; 8 x M12, dual assignment, degree of protection IP67 	6ES7 142-6BF50-0AB0 6ES7 142-6BF00-0AB0 6ES7 142-6BG00-0AB0 6ES7 142-6BR00-0AB0 6ES7 142-6BH00-0AB0	PROFINET M12 connecting cables Preassembled connecting cables with 2 M12 connectors (D-coded) in various lengths: <table border="0"> <tr><td>0.3 m</td><td>6XV1 870-8AE30</td></tr> <tr><td>0.5 m</td><td>6XV1 870-8AE50</td></tr> <tr><td>1.0 m</td><td>6XV1 870-8AH10</td></tr> <tr><td>1.5 m</td><td>6XV1 870-8AH15</td></tr> <tr><td>2.0 m</td><td>6XV1 870-8AH20</td></tr> <tr><td>3.0 m</td><td>6XV1 870-8AH30</td></tr> <tr><td>5.0 m</td><td>6XV1 870-8AH50</td></tr> <tr><td>10.0 m</td><td>6XV1 870-8AN10</td></tr> <tr><td>15.0 m</td><td>6XV1 870-8AN15</td></tr> </table>	0.3 m	6XV1 870-8AE30	0.5 m	6XV1 870-8AE50	1.0 m	6XV1 870-8AH10	1.5 m	6XV1 870-8AH15	2.0 m	6XV1 870-8AH20	3.0 m	6XV1 870-8AH30	5.0 m	6XV1 870-8AH50	10.0 m	6XV1 870-8AN10	15.0 m	6XV1 870-8AN15
0.3 m	6XV1 870-8AE30																			
0.5 m	6XV1 870-8AE50																			
1.0 m	6XV1 870-8AH10																			
1.5 m	6XV1 870-8AH15																			
2.0 m	6XV1 870-8AH20																			
3.0 m	6XV1 870-8AH30																			
5.0 m	6XV1 870-8AH50																			
10.0 m	6XV1 870-8AN10																			
15.0 m	6XV1 870-8AN15																			
ET 200eco PN digital input/output modules <ul style="list-style-type: none"> • 8 DI/DO 24 V DC/1.3 A; 8 x M12, degree of protection IP67 	6ES7 147-6BG00-0AB0	M12 connector for 24 V DC load power supply Connection socket for 24 V DC incoming supply; 4-pin, A-coded, 3 units Connector for loop-through of 24 V DC; 4-pin, A-coded, 3 units																		
ET 200eco PN analog input modules <ul style="list-style-type: none"> • 8 AI 4 U/I + 4 RTD/TC; 8 x M12, degree of protection IP67 • 8 AI RTD/TC; 8 x M12, degree of protection IP67 	6ES7 144-6KD00-0AB0 6ES7 144-6KD50-0AB0	M12 plug-in power cables Preassembled plug-in power cables, fitted at each end with M12 socket and plug 4 x 0.75 mm ² , in various lengths: <table border="0"> <tr><td>0.3 m</td><td>6XV1 801-5DE30</td></tr> <tr><td>0.5 m</td><td>6XV1 801-5DE50</td></tr> <tr><td>1.0 m</td><td>6XV1 801-5DH10</td></tr> <tr><td>1.5 m</td><td>6XV1 801-5DH15</td></tr> <tr><td>2.0 m</td><td>6XV1 801-5DH20</td></tr> <tr><td>3.0 m</td><td>6XV1 801-5DH30</td></tr> <tr><td>5.0 m</td><td>6XV1 801-5DH50</td></tr> <tr><td>10.0 m</td><td>6XV1 801-5DN10</td></tr> <tr><td>15.0 m</td><td>6XV1 801-5DN15</td></tr> </table>	0.3 m	6XV1 801-5DE30	0.5 m	6XV1 801-5DE50	1.0 m	6XV1 801-5DH10	1.5 m	6XV1 801-5DH15	2.0 m	6XV1 801-5DH20	3.0 m	6XV1 801-5DH30	5.0 m	6XV1 801-5DH50	10.0 m	6XV1 801-5DN10	15.0 m	6XV1 801-5DN15
0.3 m	6XV1 801-5DE30																			
0.5 m	6XV1 801-5DE50																			
1.0 m	6XV1 801-5DH10																			
1.5 m	6XV1 801-5DH15																			
2.0 m	6XV1 801-5DH20																			
3.0 m	6XV1 801-5DH30																			
5.0 m	6XV1 801-5DH50																			
10.0 m	6XV1 801-5DN10																			
15.0 m	6XV1 801-5DN15																			
ET 200eco PN analog output modules <ul style="list-style-type: none"> • 4 AO U/I; 4 x M12, degree of protection IP67 	6ES7 145-6HD00-0AB0	M12 coupler plug Can be assembled, for connecting actuators or sensors, 5-pin																		
ET 200eco PN IO-Link master module <ul style="list-style-type: none"> • 4 IO-L + 8 DI + 4 DO 24 V DC/1.3 A; 8 x M12, degree of protection IP67 	6ES7 148-6JA00-0AB0	Y cable M12 For double connection of I/O by means of single cable to ET 200, 5-pin																		
Accessories <ul style="list-style-type: none"> • PD voltage distributor, 24 V DC; 1 x 7/8", 4 x M12 • Terminal block for ET 200eco PN, 10 A insulation-piercing terminals • Spare fuses for terminal block, 10 units • Mounting rail 0.5 m • Profile screw for mounting rail, 50 units • Sealing cap M12 for IP67 modules, 10 units • Labels 10 x 7 mm, pastel turquoise, 816 units 	6ES7 148-6CB00-0AAA 6ES7 194-6CA00-0AAA 6ES7 194-6HB00-0AAA 6ES7 194-6GA00-0AAA 6ES7 194-6MA00-0AAA 3RX9 802-0AAA0 3RT1 900-1SB10																			

SIMATIC ET 200 distributed I/O

IO-Link master ET 200eco PN

IO-Link master ET 200eco PN

Overview



The IO-Link master module ET200eco PN is part of the compact block I/O range ET 200eco PN.

It is characterized by:

- Compact block I/O for processing digital and IO-Link signals for connection to the PROFINET bus system
- Cabinet-free installation to the IP67 degree of protection with M12 connection system
- Extremely rugged and resistant metal housing and casting
- Compact module in housing size 60 mm x 175 mm x 37 mm (W x H x D, short and wide) with 8 x M12 for digital signals and IO-Link
- PROFINET connection: 2 x M12 and automatic PROFINET address assignment
- 100 Mbit/s data transmission rate
- LLDP neighbor detection without the need for a programming device
- Supply and load voltage connection: 2 x M12
- Channel-specific diagnostics

Technical specifications

6ES7 148-6JA00-0AB0	
General information	
Vendor identification (VendorID)	002AH
Device identifier (DeviceID)	0306H
Supply voltage	
24 V DC	Yes
permissible range, lower limit (DC)	20.4 V
permissible range, upper limit (DC)	28.8 V
Reverse polarity protection	Yes
Load voltage 2L+	
• Rated value (DC)	24 V
• permissible range, lower limit (DC)	20.4 V
• permissible range, upper limit (DC)	28.8 V
• Reverse polarity protection	Yes
Input current	
from load voltage 1L+ (unswitched voltage)	4 A
from load voltage 2L+, max.	4 A
Encoder supply	
Number of outputs	6
Output current, rated value	200 mA; 100 mA per output to X5-X6
24 V encoder supply	
• Short-circuit protection	Yes
Power losses	
Power loss, typ.	8 W

6ES7 148-6JA00-0AB0	
Digital inputs	
Number/binary inputs	8
Input characteristic curve acc. to IEC 61131, Type 3	Yes
Number of simultaneously controllable inputs	
• all mounting positions - up to 60 °C, max.	8
Input voltage	
• Rated value, DC	24 V
• for signal "0"	-3 to +5 V
• for signal "1"	11 to 30 V
Input current	
• for signal "0", max. (permissible quiescent current)	1.5 mA
• for signal "1", typ.	7 mA
Input delay (for rated value of input voltage)	
• for standard inputs - at "0" to "1", max. - at "1" to "0", max.	typically 3 ms typically 3 ms
Cable length	
• Cable length unshielded, max.	30 m

SIMATIC ET 200 distributed I/O

IO-Link master ET 200eco PN

IO-Link master ET 200eco PN

Technical specifications (continued)

6ES7 148-6JA00-0AB0	
Digital outputs	
Number/binary outputs	4
Functionality/short-circuit strength	Yes; Electronic
• Response threshold, typ.	1.8 A
Limitation of inductive shutdown voltage to	Typ. (L1+, L2+) -47 V
Controlling a digital input	Yes
Switching capacity of the outputs	
• on lamp load, max.	5 W
Output current	
• for signal "1" rated value	1.3 A; Maximum
• for signal "0" residual current, max.	1.5 mA
Parallel switching of 2 outputs	
• for increased power	No
• for redundant control of a load	Yes
Switching frequency	
• with resistive load, max.	100 Hz
• with inductive load, max.	0.5 Hz
• on lamp load, max.	1 Hz
Aggregate current of outputs (per group)	
• all mounting positions	
- up to 60 °C, max.	3.9 A
Cable length	
• Cable length unshielded, max.	30 m
IO-Link	
Number of ports	4
• of which simultaneously controllable	4
Transmission rate	4.8 kBd (COM1); 38.4 kBd (COM2)
Cable length unshielded, max.	20 m
Operating modes	
• IO-Link	Yes
• DI	Yes
• DO	Yes
Connection of IO-Link devices	
• via 3-wire connection	Yes
Interfaces	
Transmission procedure	100BASE-TX
Transmission rate, max.	100 Mbit/s
Supports protocol for PROFINET IO	
• Number of PROFINET interfaces	2
• Autocrossing	Yes
• Automatic detection of transmission speed	Yes
• Integrated switch	Yes
• PROFINET IO Device	
- IRT with the option "high flexibility" supported	Yes

6ES7 148-6JA00-0AB0	
Protocols	
Supports protocol for PROFINET IO	Yes
Protocols (Ethernet)	
• SNMP	Yes
• DCP	Yes
• LLDP	Yes
• ping	Yes
• arp	Yes
Interrupts/diagnostics/status information	
Status indicator	Yes; Green LED
Alarms	
• Diagnostic alarm	Yes
Diagnostic messages	
• Diagnostic functions	Yes
• Diagnostic information readable	Yes
• Monitoring the supply voltage	Yes; Green "ON" LED
• Wire break in actuator cable	Yes
• Wire break in signal transmitter cable	Yes
• Short circuit	Yes
• Short circuit encoder supply	Yes
• Group error	Yes; Red/yellow "SF/MT" LED
Galvanic isolation	
between the load voltages	Yes
between load voltage and all other switching components	No
between Ethernet and electronics	Yes
Galvanic isolation digital inputs	
• between the channels	No
Galvanic isolation digital outputs	
• between the channels	No
Permissible potential difference	
between different circuits	75 VDC / 60 VAC
Isolation	
tested with	
• 24 V DC circuits	500 V
• Interface	1 500 V; According to IEEE 802.3
Degree and class of protection	
IP65	Yes
IP66	Yes
IP67	Yes
Connection method	
M12	Yes
Dimensions	
Width	60 mm
Height	175 mm
Depth	49 mm
Weight	
Weight	910 g

SIMATIC ET 200 distributed I/O

IO-Link master ET 200eco PN

IO-Link master ET 200eco PN

Ordering data	Order No.	Order No.
IO-Link Master ET 200eco PN • 4 IO-L + 8 DI + 4 DO 24 V DC/1.3 A; 8 x M12, degree of protection IP67	6ES7 148-6JA00-0AB0	
Accessories • PD voltage distributor, 24 V DC; 1 X 7/8", 4 X M12 • Terminal block for ET 200eco PN, 10 A insulation-piercing terminals • Spare fuses for terminal block, 10 units • Mounting rail 0.5 m • Profile screw for mounting rail, 50 units • Sealing cap M12 for IP67 modules, 10 units • Labels 10 x 7 mm, pastel turquoise, 816 units	6ES7 148-6CB00-0AA0 6ES7 194-6CA00-0AA0 6ES7 194-6HB00-0AA0 6ES7 194-6GA00-0AA0 6ES7 194-6MA00-0AA0 3RK1 901-1KA00 3RT1 900-1SB10	M12 connector for 24 V DC load power supply Connection socket for 24 V DC incoming supply; 4-pin, A-coded, 3 units Connector for loop-through of 24 V DC; 4-pin, A-coded, 3 units
PROFINET M12 connector, for user assembly IE FC M12 connector PRO, for user assembly • 1 unit • 8 units	6GK1 901-0DB20-6AA0 6GK1 901-0DB20-6AA8	M12 plug-in power cables Preassembled plug-in power cables, fitted at each end with M12 socket and plug 4 x 0.75 mm ² , in various lengths: 0.3 m 0.5 m 1.0 m 1.5 m 2.0 m 3.0 m 5.0 m 10.0 m 15.0 m
PROFINET M12 connecting cables Preassembled connecting cables with 2 M12 connectors (D-coded), in various lengths: 0.3 m 0.5 m 1.0 m 1.5 m 2.0 m 3.0 m 5.0 m 10.0 m 15.0 m	6XV1 870-8AE30 6XV1 870-8AE50 6XV1 870-8AH10 6XV1 870-8AH15 6XV1 870-8AH20 6XV1 870-8AH30 6XV1 870-8AH50 6XV1 870-8AN10 6XV1 870-8AN15	Y cable M12 For double connection of I/O by means of a single-cable on ET200, 5-pole
		6GK1 907-0DC10-6AA3 6GK1 907-0DB10-6AA3 6XV1 801-5DE30 6XV1 801-5DE50 6XV1 801-5DH10 6XV1 801-5DH15 6XV1 801-5DH20 6XV1 801-5DH30 6XV1 801-5DH50 6XV1 801-5DN10 6XV1 801-5DN15 6ES7 194-6KA00-0XA0

Overview



- Compact, cost-effective I/O devices for processing digital signals
- Design without control cabinet with degree of protection IP65/67 with flexible and fast connections
- Comprises a basic module and various connection blocks for application-specific implementation options:
 - ECOFAST: 2 x RS 485 hybrid fieldbus connection with identification plug for setting the PROFIBUS address
 - M12: 2 x M12 and 2 x 7/8" with 2 rotary coding switches for assigning the PROFIBUS address
- Connection block contains T-functionality for bus and power supply so that during commissioning and service, the modules can be disconnected from and reconnected to the PROFIBUS without interruption
- Module variance: 8DI, 16DI, 8DI/8DO (1.3 A), 8DI/8DO (2.0 A), 8DO (2.0 A), 16DO (0.5 A)
- Transmission rates up to 12 Mbit/s
- Failsafe DI modules 4/8 F-DI with safety-related signal processing according to PROFIsafe

Technical specifications

	6ES7 141-3BF00-0XA0	6ES7 141-3BH00-0XA0	6ES7 148-3FA00-0XB0
General information			
Vendor identification (VendorID)	80DBh	80DAh	
FH technology			
Module for failsafe applications			Yes
Supply voltage			
Rated value (DC)	24 V	24 V	24 V
Reverse polarity protection	Yes	Yes	No
Input current			
from supply voltage 1L+, max.	70 mA; typ.	70 mA; typ.	100 mA
Encoder supply			
Number of outputs	8	8	2
Output voltage	24 V DC	24 V DC	min. L+ (-1.5 V)
Output current, rated value	1 A; Aggregate current up to 55 °C	1 A; Aggregate current up to 55 °C	300 mA
Output current			
• Short-circuit protection	Yes; Electronic	Yes; Electronic	Yes
Power losses			
Power loss, typ.	2.4 W	3.6 W	3 W
Digital inputs			
Number/binary inputs	8	16	8; 8 single channel, 4 two-channel
Input characteristic curve acc. to IEC 61131, Type 1	Yes	Yes	Yes
Number of simultaneously controllable inputs	8; All mounting positions up to 55 °C	16; All mounting positions up to 55 °C	8; 8 single channel, 4 two-channel
Input voltage			
• Type of input voltage	DC	DC	DC
• Rated value, DC	24 V	24 V	24 V
• for signal "0"	-3 to +5 V	-3 to +5 V	-30 to +5 V
• for signal "1"	13 to 30 V	13 to 30 V	15 to 30 V
Input current			
• for signal "1", typ.	7 mA	7 mA	3.7 mA

SIMATIC ET 200 distributed I/O

ET 200eco

ET 200eco

Technical specifications (continued)

	6ES7 141-3BF00-0XA0	6ES7 141-3BH00-0XA0	6ES7 148-3FA00-0XB0
Input delay (for rated value of input voltage)			
• for standard inputs			
- at "0" to "1", max.	3 ms; typ.	3 ms; typ.	
- at "1" to "0", max.	3 ms; typ.	3 ms; typ.	
Cable length			
• Cable length unshielded, max.	30 m	30 m	30 m
Encoder			
Connectable encoders			
• 2-wire sensor	Yes	Yes	No
- Permissible quiescent current (2-wire sensor), max.	1.5 mA	1.5 mA	
Interfaces			
PROFIBUS DP			
• Transmission rate, max.	12 Mbit/s; 9.6 / 19.2 / 45.45 / 93.75 / 187.5 / 500 Kbit/s; 1.5 / 3 / 6 / 12 Mbit/s	12 Mbit/s; 9.6 / 19.2 / 45.45 / 93.75 / 187.5 / 500 Kbit/s; 1.5 / 3 / 6 / 12 Mbit/s	12 Mbit/s
Protocols			
PROFIBUS DP	Yes	Yes	Yes
Interrupts/diagnostics/ status information			
Status indicator	Yes	Yes	
Alarms			
• Alarms	No	No	
Diagnostic messages			
• Diagnostics	Yes; Diagnostic information readable	Yes; Diagnostic information readable	
Diagnostics indication LED			
• Group error SF (red)	Yes	Yes	Yes
• Status indicator digital input (green)	Yes	Yes	Yes
• Channel error indicator F (red)	No	No	No
Galvanic isolation			
between PROFIBUS DP and all other circuit components	Yes	Yes	Yes
Galvanic isolation digital inputs			
• between the channels	No	No	No
Permissible potential difference			
between different circuits	75 VDC / 60 VAC	75 VDC / 60 VAC	75 VDC / 60 VAC
Isolation			
Isolation checked with	500 V DC	500 V DC	500 V AC for 1 min.
Standards, approvals, certificates			
Highest safety class achievable in safety mode			
• acc. to IEC 61508			SIL 2 (single-channel), SIL 3 (two-channel)
Dimensions			
Width	60 mm	60 mm	60 mm
Height	210 mm	210 mm	210 mm
Depth	28 mm	28 mm	28 mm
Weight			
Weight, approx.	210 g	210 g	220 g

Technical specifications (continued)

	6ES7 142-3BF00-0XA0	6ES7 142-3BH00-0XA0
General information		
Vendor identification (VendorID)	80DDh	80FBh
Supply voltage		
Rated value (DC)	24 V	24 V
Reverse polarity protection	Yes	Yes
Load voltage 2L+		
• Rated value (DC)	24 V	24 V
• Reverse polarity protection	Yes	Yes
Input current		
from load voltage 2L+ (without load), max.	60 mA; typ.	80 mA; typ.
from supply voltage 1L+, max.	70 mA; typ.	70 mA; typ.
Power losses		
Power loss, typ.	4 W	4 W
Digital outputs		
Number/binary outputs	8	16
Functionality/short-circuit strength	Yes; Electronic	Yes; Electronic
• Response threshold, typ.	4 A per channel	1.4 A (per channel)
Limitation of inductive shutdown voltage to	2L+ (-44 V)	2L+ (-47 V)
Lamp load, max.	10 W	5 W
Controlling a digital input	Yes	Yes
Load resistance range		
• lower limit	12 Ω	12 Ω
• upper limit	4 kΩ	4 kΩ
Output voltage		
• for signal "1", min.	2L+ (-0.8 V)	2L+ (-0.8 V)
Output current		
• for signal "1" rated value	2 A	0.5 A
• for signal "1" permissible range for 0 to 55 °C, min.	5 mA	5 mA
• for signal "1" permissible range for 0 to 55 °C, max.	2.4 A	1 A
• for signal "0" residual current, max.	0.5 mA	0.1 mA
Parallel switching of 2 outputs		
• for increased power	No	No
• for redundant control of a load	Yes	Yes
Switching frequency		
• with resistive load, max.	100 Hz	100 Hz
• with inductive load, max.	0.5 Hz; to IEC 947-5-1, DC13	0.5 Hz; to IEC 947-5-1, DC13
• on lamp load, max.	1 Hz	1 Hz
Aggregate current of outputs (per group)		
• all mounting positions - up to 55 °C, max.	4 A; 4 A each for sockets X1, X3, X5, X7 and 4 A each for sockets X2, X4, X6, X8; note the current carrying capacity of the cable	4 A; Please note the current carrying capacity of the cable!
Cable length		
• Cable length unshielded, max.	30 m	30 m
Interfaces		
PROFIBUS DP		
• Transmission rate, max.	12 Mbit/s; 9.6 / 19.2 / 45.45 / 93.75 / 187.5 / 500 Kbit/s; 1.5 / 3 / 6 / 12 Mbit/s	12 Mbit/s; 9.6 / 19.2 / 45.45 / 93.75 / 187.5 / 500 Kbit/s; 1.5 / 3 / 6 / 12 Mbit/s
Protocols		
PROFIBUS DP	Yes	Yes

SIMATIC ET 200 distributed I/O

ET 200eco

ET 200eco

Technical specifications (continued)

	6ES7 142-3BF00-0XA0	6ES7 142-3BH00-0XA0
Interrupts/diagnostics/ status information		
Status indicator	Yes	Yes
Alarms		
• Alarms	No	No
Diagnostic messages		
• Diagnostics	Yes; Diagnostic information readable	Yes; Diagnostic information readable
Diagnosics indication LED		
• Group error SF (red)	Yes	Yes
• Status indicator digital output (green)	Yes	Yes
• Channel error indicator F (red)	No	No
Galvanic isolation		
between PROFIBUS DP and all other circuit components	Yes	Yes
Galvanic isolation digital outputs		
• between the channels	No	No
Permissible potential difference		
between different circuits	75 VDC / 60 VAC	75 VDC / 60 VAC
Isolation		
Isolation checked with	500 V DC	500 V DC
Dimensions		
Width	60 mm	60 mm
Height	210 mm	210 mm
Depth	28 mm	28 mm
Weight		
Weight, approx.	210 g	210 g

	6ES7 143-3BH00-0XA0	6ES7 143-3BH10-0XA0
General information		
Vendor identification (VendorID)	80DCh	80FCh
Supply voltage		
Rated value (DC)	24 V	24 V
Reverse polarity protection	No	Yes
Load voltage 2L+		
• Rated value (DC)	24 V	24 V
• Reverse polarity protection	No	Yes
Input current		
from load voltage 2L+ (without load), max.	60 mA; typ.	60 mA; typ.
from supply voltage 1L+, max.	70 mA; typ.	70 mA; typ.
Encoder supply		
Number of outputs	8	8
Output voltage	24 V DC	
Output current, rated value	0.75 A; up to 55°C max. 0.75 A (summation current)	1 A; Up to 55°C max. 1 A (summation current)
Output current		
• Short-circuit protection	Yes; Electronic	Yes; Electronic
Power losses		
Power loss, typ.	5 W	5 W

Technical specifications (continued)

	6ES7 143-3BH00-0XA0	6ES7 143-3BH10-0XA0
Digital inputs		
Number/binary inputs	8	8
Input characteristic curve acc. to IEC 61131, Type 1	Yes	Yes
Number of simultaneously controllable inputs	8; All mounting positions up to 55 °C	8; All mounting positions up to 55 °C
Input voltage		
• Type of input voltage	DC	DC
• Rated value, DC	24 V	24 V
• for signal "0"	-3 to +5 V	-3 to +5 V
• for signal "1"	13 to 30 V	13 to 30 V
Input current		
• for signal "1", typ.	7 mA	7 mA
Input delay (for rated value of input voltage)		
• for standard inputs		
- at "0" to "1", max.	3 ms; typ.	3 ms; typ.
- at "1" to "0", max.	3 ms; typ.	3 ms; typ.
Digital outputs		
Number/binary outputs	8	8
Functionality/short-circuit strength	Yes; Electronic	Yes; Electronic
• Response threshold, typ.	4 A per channel	4 A per channel
Limitation of inductive shutdown voltage to	2L+ (-44 V)	2L+ (-44 V)
Lamp load, max.	10 W	10 W
Controlling a digital input	Yes	Yes
Load resistance range		
• lower limit	12 Ω	12 Ω
• upper limit	4 kΩ	4 kΩ
Output voltage		
• for signal "1", min.	2L+ (-0.8 V)	2L+ (-1.2 V)
Output current		
• for signal "1" rated value	2 A	1.3 A
• for signal "1" permissible range for 0 to 55 °C, min.	5 mA	5 mA
• for signal "1" permissible range for 0 to 55 °C, max.	2.4 A	1.8 A
• for signal "0" residual current, max.	0.5 mA	0.5 mA
Parallel switching of 2 outputs		
• for increased power	No	No
• for redundant control of a load	Yes	Yes
Switching frequency		
• with resistive load, max.	100 Hz	100 Hz
• with inductive load, max.	0.5 Hz; to IEC 947-5-1, DC13	0.5 Hz; to IEC 947-5-1, DC13
• on lamp load, max.	1 Hz	1 Hz
Aggregate current of outputs (per group)		
• all mounting positions - up to 55 °C, max.	4 A; 4 A each for sockets X1, X3, X5, X7 and 4 A each for sockets X2, X4, X6, X8; note the current carrying capacity of the cable	5.2 A; Please note the current carrying capacity of the cable!
Cable length		
• Cable length unshielded, max.	30 m	30 m
Encoder		
Connectable encoders		
• 2-wire sensor	Yes	Yes
- Permissible quiescent current (2-wire sensor), max.	1.5 mA	1.5 mA

SIMATIC ET 200 distributed I/O

ET 200eco

ET 200eco

Technical specifications (continued)

	6ES7 143-3BH00-0XA0	6ES7 143-3BH10-0XA0
Interfaces		
PROFIBUS DP		
• Transmission rate, max.	12 Mbit/s; 9.6 / 19.2 / 45.45 / 93.75 / 187.5 / 500 Kbit/s; 1.5 / 3 / 6 / 12 Mbit/s	12 Mbit/s; 9.6 / 19.2 / 45.45 / 93.75 / 187.5 / 500 Kbit/s; 1.5 / 3 / 6 / 12 Mbit/s
Protocols		
PROFIBUS DP	Yes	Yes
Interrupts/diagnostics/ status information		
Status indicator	Yes	Yes
Alarms		
• Alarms	No	No
Diagnostic messages		
• Diagnostics	Yes; Diagnostic information readable	Yes; Diagnostic information readable
Diagnosics indication LED		
• Group error SF (red)	Yes	Yes
• Status indicator digital output (green)	Yes	Yes
• Status indicator digital input (green)	Yes	Yes
• Channel error indicator F (red)	No	No
Galvanic isolation		
between PROFIBUS DP and all other circuit components	Yes	Yes
Galvanic isolation digital inputs		
• between the channels	No	No
Galvanic isolation digital outputs		
• between the channels	No	No
Permissible potential difference		
between different circuits	75 VDC / 60 VAC	75 VDC / 60 VAC
Isolation		
Isolation checked with	500 V DC	500 V DC
Dimensions		
Width	60 mm	60 mm
Height	210 mm	210 mm
Depth	28 mm	28 mm
Weight		
Weight, approx.	210 g	210 g
6ES7 194-3AA00-0AA0		
6ES7 194-3AA00-0BA0		
Power losses		
Power loss, typ.	2 W; The power loss depends on the current that you loop through via the connection block.	2 W; The power loss depends on the current that you loop through via the connection block.
Dimensions		
Width	79 mm	79 mm
Height	60 mm	60 mm
Depth	30 mm	29 mm
Weight		
Weight, approx.	313 g	392 g

Ordering data	Order No.	Order No.
BM 141 ET 200eco basic modules <ul style="list-style-type: none"> 8 DI DC 24 V 8 x M12, individual assignment, IP65/67 connection block 6ES7194-3AA00-0.A0 to be ordered separately 16 DI DC 24 V 8 x M12, double assignment, IP65/67 connection block 6ES7194-3AA00-0.A0 to be ordered separately 	6ES7 141-3BF00-0XA0 6ES7 141-3BH00-0XA0	M12 connection block, 7/8" accessories PROFIBUS M12 cable connector 1 pack = 5 units <ul style="list-style-type: none"> Male insert Female insert
BM 142 ET 200eco basic module <ul style="list-style-type: none"> 8 DO DC 24 V/1.2 A 8 x M12, individual assignment, P65/67 connection block 6ES7194-3AA00-0.A0 to be ordered separately 16 DO DC 24 V/0.5 A 8 x M12, double assignment, IP65/67; connection block 6ES7 194-3AA00-0.A0 to be ordered separately 	6ES7 142-3BF00-0XA0 6ES7 142-3BH00-0XA0	PROFIBUS M12 connecting cable for PROFIBUS DP, 1 pack = 5 units <ul style="list-style-type: none"> Male insert
BM 143 ET 200eco basic modules <ul style="list-style-type: none"> 8 DI/8 DO, 2 A 8 x M12, IP65/67 connection block 6ES7194-3AA00-0.A0 to be ordered separately 8 DI/8 DO, 1.3 A 8 x M12, double assignment, IP65/67 connection block 6ES7 194-3AA00-0.A0 to be ordered separately 	6ES7 143-3BH00-0XA0 6ES7 143-3BH10-0XA0	PROFIBUS M12 connecting cable Preassembled 2-wire (inverse coded) with M12 connectors (straight) in various lengths: <ul style="list-style-type: none"> 0.3 m 0.5 m 1.0 m 1.5 m 2.0 m 3.0 m 5.0 m 10.0 m 15.0 m Other special lengths with 90° or 180° cable outlet
BM 148 ET 200eco basic modules <ul style="list-style-type: none"> 4/8 F-DI, 8 x M12, connection block 6ES7194-3AA00-0.A0 to be ordered separately 	6ES7 148-3FA00-0XB0	7/8" connector 1 pack = 5 units <ul style="list-style-type: none"> Male contact insert, straight Male contact insert, angled Female contact insert, straight Female contact insert, angled
ECOFAST connection block for ET 200eco, 2 x ECOFAST connection RS485 identification connector for PROFIBUS DP, address setting	6ES7 194-3AA00-0AA0	7/8" sealing caps 1 pack = 10 units
M12 connection block, 7/8" for ET 200eco, 2 x M12 and 2 x 7/8" 2 rotary coding switch for PROFIBUS DP, address setting	6ES7 194-3AA00-0BA0	SIMATIC NET energy cable 5-wire energy cable, stranded 5 x 1.5 mm ² , trailing-type <ul style="list-style-type: none"> Sold by the meter, minimum order quantity = 20 m
Accessory for ECOFAST connection block PROFIBUS ECOFAST hybrid plug <ul style="list-style-type: none"> Female contact insert, straight Female contact insert, angled Male contact insert, straight Male contact insert, angled 	6GK1 905-0CB00 6GK1 905-0CD00 6GK1 905-0CA00 6GK1 905-0CC00	7/8" connecting cable to power supply Preassembled 5-wire cable with 7/8" connectors (straight) in various lengths: <ul style="list-style-type: none"> 0.3 m 0.5 m 1.0 m 1.5 m 2.0 m 3.0 m 5.0 m 10.0 m 15.0 m
PROFIBUS ECOFAST terminating plug ECOFAST terminating resistor for PROFIBUS DP <ul style="list-style-type: none"> 1 pack = 1 unit 1 pack = 5 units 	6GK1 905-0DA10 6GK1 905-0DA00	Preassembled 5-wire cable with 7/8" connectors (straight) in various lengths: <ul style="list-style-type: none"> 3.0 m 5.0 m 10.0 m Other special lengths with 90° or 180° cable outlet
PROFIBUS ECOFAST Hybrid cable – Cu	See ECOFAST bus cables	6XV1 830-8AH10 6XV1 822-5BE30 6XV1 822-5BE50 6XV1 822-5BH10 6XV1 822-5BH15 6XV1 822-5BH20 6XV1 822-5BH30 6XV1 822-5BH50 6XV1 822-5BN10 6XV1 822-5BN15 3RK1 902-3NB30 3RK1 902-3NB50 3RK1 902-3NC10 see http://support.automation.siemens.com/WW/view/en/26999294

SIMATIC ET 200 distributed I/O

ET 200eco

ET 200eco

Ordering data	Order No.	Order No.
Other accessories		
Identification connector For setting the PROFIBUS station address	6ES7 194-1KB00-0XA0	
Y circular connector M12 For double connection of sensors via a single cable, 5-pole; cannot be used for F DI 4/8	6ES7 194-1KA01-0XA0	
Y cable M12 For double connection of sensors via a single cable, 5-pole; cannot be used for F DI 4/8	6ES7 194-6KA00-0XA0	
M12 coupler plug for connecting actuators or sensors, 5-pole	3RK1 902-4BA00-5AA0	
M12 covering caps for sealing of unused I/O sockets	3RX9 802-0AA00	
Labels	3RT1 900-1SB20	
S7 Distributed Safety V5.4 programming tool Task: Engineering tool for configuring fail-safe user programs for SIMATIC S7-300F, S7-400F, ET 200S Requirement: STEP 7 V5.3 SP3 and higher Floating license	6ES7 833-1FC02-0YA5	
Floating license for 1 user, license key download without software and documentation ¹⁾ ; email address required for delivery	6ES7 833-1FC02-0YH5	
S7 Distributed Safety Upgrade from V5.x to V5.4; Floating license for 1 user	6ES7 833-1FC02-0YE5	
		STEP 7 Safety Advanced V11 Task: Engineering tool for configuring fail-safe user programs for SIMATIC S7-300F, S7-400F, WinAC RTX F, ET 200S, ET 200M, ET 200iSP, ET 200pro, ET 200eco Requirement: STEP 7 Professional V11 SP1 Floating license for 1 user Floating license for 1 user, license key download without software and documentation ¹⁾ ; email address required for delivery
		6ES7 833-1FA11-0YA5 6ES7 833-1FA11-0YH5
		STEP 7 Safety Advanced Upgrade Distributed Safety V5.4 SP5 and STEP 7 Safety Advanced V11 for parallel use; incl. software on CD; Combo License for 1 user Distributed Safety V5.4 SP5 and STEP 7 Safety Advanced V11 for parallel use; incl. software on CD; Combo License for 1 user, license key download without software and documentation ¹⁾ ; email address required for delivery
		6ES7 833-1FA11-0YE5 6ES7 833-1FA11-0YK5
		S7 Manual Collection Electronic manuals on DVD, multi-language: S7-200, TD 200, S7-300, M7-300, C7, S7-400, M7-400, STEP 7, Engineering Tools, Runtime Software, SIMATIC DP (Distributed I/O), SIMATIC HMI (Human Machine Interface), SIMATIC NET (Industrial Communication)
		6ES7 998-8XC01-8YE0
		S7 Manual Collection update service for 1 year Scope of delivery: Current DVD "S7 Manual Collection" and the three subsequent updates
		6ES7 998-8XC01-8YE2

SIMATIC ET 200 distributed I/O

PROFIBUS components

Power Rail Booster

Overview



- The device for low-cost PROFIBUS DP transfer over contact conductors and slip rings to degree of protection IP20
- Permissible baud rates from 9600 bit/s to 500 kbit/s, self-optimizing
- Permissible busbar length:
From 25 m at 500 kbit/s to 1200 m at 9600 bit/s
- Configuring with PRB Checker software
- Up to 125 nodes per segment
- Transparent for data communication:
The power rail booster does not reserve DP addresses
- Easy to install due to connection without terminating resistor and filter element
- Diagnostics LED for power supply, bus activity and group errors
- Isolated electronic changeover contact for external group error display or diagnostic alarm
- Uninterruptible communication beyond segment limits using the "PRB segment controller"

Technical specifications

Degree of protection	IP20
Dimensions (W x H x D, with connector) in mm	90 x 132 x 75
Supply voltage	24 V DC
Power consumption	max. 20 W
Data transmission rate, max.	500 kbit/s, self-adjusting
Cable length (depends on baud rate), max.	1200 m
Shock-hazard protected voltage	Yes, to EN 61131-2
Stations per PRB segment, max.	125
Operation without terminating resistance	Yes
Operation without filter	Yes
Wiring options: Line / star	Yes / Yes

Ordering data

Order No.

Power Rail Booster

Signal amplifier for PROFIBUS DP transmission over contact cables, max. 500 kbit/s

6ES7 972-4AA02-0XA0

PRB segment controller

Automatic change-over switch between PRB segments

6ES7 972-4AA50-0XA0

SIMATIC ET 200 distributed I/O

PROFIBUS components

Diagnostic repeater for PROFIBUS DP

Overview



- RS 485 repeater with online line diagnostics for PROFIBUS DP
- DP standard PROFIBUS slave (DP-V1)
- Automatic determination of fault types and locations
- Data transmission rate 9.6 kbit/s to 12 Mbit/s
- Connection through FastConnect using the insulation displacement method

Technical specifications

6ES7 972-0AB01-0XA0	
Supply voltage	
24 V DC	Yes
permissible range, lower limit (DC)	20.4 V
permissible range, upper limit (DC)	28.8 V
Interfaces	
Bus cables	FastConnect insulation displacement, 10 clamping cycles possible
PROFIBUS DP	
• Transmission rate, max.	12 Mbit/s; 9.6 kbit/s to 12 Mbit/s
Degree and class of protection	
IP20	Yes
Ambient conditions	
Operating temperature	
• Min.	0 °C
• max.	60 °C
Storage/transport temperature	
• Min.	-40 °C
• max.	70 °C
Relative humidity	
• Operation, max.	95 %; at 25 °C
Connection method	
Power supply	Terminal block
Dimensions	
Width	80 mm
Height	125 mm
Depth	67.5 mm
Weight	
Weight, approx.	300 g

SIMATIC ET 200 distributed I/O PROFIBUS components

Diagnostic repeater for PROFIBUS DP

Ordering data	Order No.	Order No.
RS 485 Diagnostic Repeater For connection of 1 or 2 segments to PROFIBUS DP; with online diagnostics functions for monitoring the bus cables	6ES7 972-0AB01-0XA0	
Accessories RS 485 bus connector with 90° cable outlet With screw terminals Max. transfer rate 12 Mbit/s <ul style="list-style-type: none"> • Without PG interface • With PG interface 	6ES7 972-0BA12-0XA0 6ES7 972-0BB12-0XA0	PROFIBUS FastConnect RS 485 bus connector with angular cable outlet (35°) With insulation displacement terminals, max. transfer rate 12 Mbit/s <ul style="list-style-type: none"> • Without PG interface • With PG interface
PROFIBUS FastConnect bus connector RS 485 with 90° cable outlet With insulation displacement terminals Max. data transfer rate 12 Mbit/s <ul style="list-style-type: none"> • Without PG interface • 1 unit • 100 units With PG interface <ul style="list-style-type: none"> • 1 unit • 100 units Without PG interface, grounding via control cabinet cover <ul style="list-style-type: none"> • 1 unit With PG interface, grounding via control cabinet cover <ul style="list-style-type: none"> • 1 unit 	6ES7 972-0BA52-0XA0 6ES7 972-0BA52-0XB0 6ES7 972-0BB52-0XA0 6ES7 972-0BB52-0XB0 6ES7 972-0BA70-0XA0 6ES7 972-0BB70-0XA0	PROFIBUS FastConnect Stripping Tool Preadjusted stripping tool for fast stripping of PROFIBUS FastConnect bus cables
RS 485 bus connector with angled cable outlet (35°) With screw terminals, max. transfer rate 12 Mbit/s <ul style="list-style-type: none"> • Without PG interface • With PG interface 	6ES7 972-0BA42-0XA0 6ES7 972-0BB42-0XA0	PROFIBUS FC Standard Cable Standard type with special design for quick mounting, 2-core, shielded, sold by the meter, max. delivery unit 1000 m, minimum order quantity 20 m
		S7 Manual Collection Electronic manuals on DVD, multilingual: S7-200, TD 200, S7-300, M7-300, C7, S7-400, M7-400, STEP 7, Engineering Tools, Runtime Software, SIMATIC DP (Distributed I/O), SIMATIC HMI (Human Machine Interface), SIMATIC NET (Industrial Communication)
		S7 Manual Collection update service for 1 year Scope of delivery: Current DVD "S7 Manual Collection" and the three subsequent updates
		Connecting cable for PROFIBUS 12 Mbit/s, for PG connection to PROFIBUS DP, preassembled with 2 x 9-pin sub D connector, 3.0 m
		6ES7 972-0BA60-0XA0 6ES7 972-0BB60-0XA0 6GK1 905-6AA00 6XV1 830-0EH10 6ES7 998-8XC01-8YE0 6ES7 998-8XC01-8YE2 6ES7 901-4BD00-0XA0

SIMATIC ET 200 distributed I/O

PROFIBUS components

PROFIBUS DP ASICs

Overview

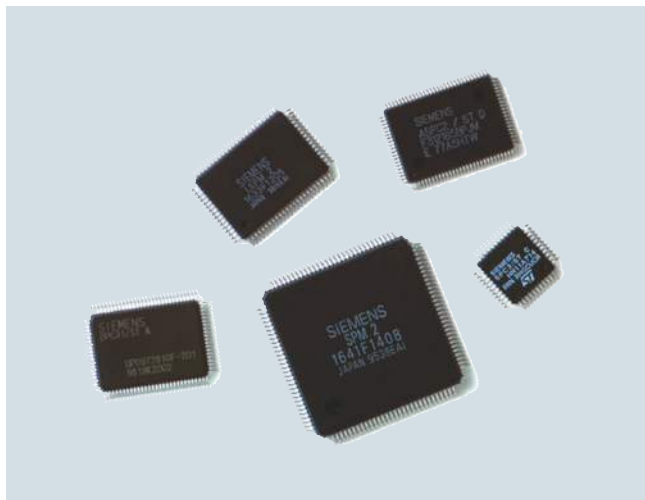

- Easy connection of field devices to PROFIBUS
- Integrated low power management
- Different ASICs for the different functional requirements and application areas

Technical specifications

	LSPM 2	SPC 3	SPC 3LV	DPC 31
Protocol	PROFIBUS DP	PROFIBUS DP	PROFIBUS DP	PROFIBUS DP, PROFIBUS PA
Application range	simple slave application	intelligent slave application	intelligent slave application	intelligent slave application
Transmission rate, max.	12 Mbit/s	12 Mbit/s	12 Mbit/s	12 Mbit/s
Bus access	in ASIC	in ASIC	in ASIC	in ASIC
Automatic determination of transmission rate	yes	yes	yes	yes
Microprocessor required	no	yes	yes	integrated
Scope of firmware	not required	6 to 24 KB	6 to 24 KB	approx. 38 KB
Message buffer	-	1.5 KB	1.5 KB	6 KB
Power supply	5 V DC	5 V DC	3.3 V DC	3.3 V DC
Power loss, max.	0.35 W	0.5 W	<0.5 W	0.2 W
Permissible ambient temperature	-40 °C ... +75 °C	-40 °C ... +85 °C	-40 °C ... +85 °C	-40 °C ... +85 °C
Housing	MQFP, 80-pin	PQFP, 44-pin	PQFP, 44-pin	PQFP, 100-pin
Frame size	4 cm ²	2 cm ²	2 cm ²	4 cm ²
Delivery quantities (pcs.)	6/66/330/4950	6/96/750/960/4800	5/160/800/1000/4800	STEP B: 6/60/300/5100 STEP C 1: 6/66/660/4620

	SPC 4-2	ASPC 2	SIM 1-2	FOC SI
Protocol	PROFIBUS DP PROFIBUS FMS PROFIBUS PA	PROFIBUS DP PROFIBUS FMS PROFIBUS PA	PROFIBUS PA	-
Application range	Intelligent slave application	Master application	Medium Attachment	Medium Management Unit
Transmission rate, max.	12 Mbit/s	12 Mbit/s	31.25 kbit/s	12 Mbit/s
Bus access	in ASIC	in ASIC	-	-
Automatic determination of transmission rate	yes	yes	-	-
Microprocessor required	yes	yes	-	-
Scope of firmware	3 ... 30 KB	80 KB	not required	not required
Message buffer	3 KB	1 MB (external)	-	-
Voltage supply	5 V DC, 3.3 V	5 V DC	via bus	3.3 V DC
Power loss, max.	0.6 W at 5V 0.01 W at 3.3 V	0.9 W	0.05 W	0.75 W
Permissible ambient temperature	-40 °C ... +85 °C	-40 °C ... +85 °C	-40 °C ... +85 °C	-40 °C ... +85 °C
Housing	TQFP, 44-pin	P-MQFP, 100-pin	MLPQ, 40-pin	TQFP, 44-pin
Frame size	2 cm ²	4 cm ²	36 mm ²	2 cm ²
Delivery quantities (pcs.)	5/160	6/66/660/4620	30/60/1000	40

SIMATIC ET 200 distributed I/O PROFIBUS components

PROFIBUS DP ASICs

Ordering data	Order No.	Order No.
ASIC ASPC 2 For constructing master interfaces (quantity discount) <ul style="list-style-type: none"> • 6 units (lead-free) • 66 units (lead-free) • 660 units (lead-free) • 4620 units (lead-free) 	6ES7 195-0AA05-0XA0 6ES7 195-0AA15-0XA0 6ES7 195-0AA25-0XA0 6ES7 195-0AA35-0XA0	ASIC DPC 31 STEP B For constructing intelligent DP slave interfaces (quantity discounts) <ul style="list-style-type: none"> • 6 units (lead-free) • 60 units (lead-free) • 300 units (lead-free) • 5100 units (lead-free)
ASIC LSPM 2 For constructing simple slave interfaces (quantity discount) <ul style="list-style-type: none"> • 6 units (lead-free) • 66 units (lead-free) • 330 units (lead-free) • 4950 units (lead-free) 	6ES7 195-0BA02-0XA0 6ES7 195-0BA12-0XA0 6ES7 195-0BA22-0XA0 6ES7 195-0BA32-0XA0	ASIC DPC 31 STEP C1 For constructing intelligent DP slave interfaces (quantity discounts) <ul style="list-style-type: none"> • 6 units (lead-free) • 66 units (lead-free) • 660 units (lead-free) • 4620 units (lead-free)
ASIC SPC 3 For constructing intelligent DP slave interfaces (quantity discounts) <ul style="list-style-type: none"> • 6 units (lead-free) • 96 units (lead-free) • 960 units (lead-free) • 4800 units (lead-free) • 750 units (lead-free) T&R 	6ES7 195-0BD04-0XA0 6ES7 195-0BD14-0XA0 6ES7 195-0BD24-0XA0 6ES7 195-0BD34-0XA0 6ES7 195-0BD44-0XA0	ASIC SPC 4-2 For constructing intelligent DP slave interfaces (quantity discounts) <ul style="list-style-type: none"> • 5 units for laboratory development (lead-free) • 160 units (lead-free, 1 tray)
ASIC SPC 3LV For constructing intelligent DP slave interfaces (quantity discounts) <ul style="list-style-type: none"> • 5 units (lead-free) • 160 units (lead-free) • 800 units (lead-free) • 4800 units (lead-free) • 1000 units (lead-free) T&R 	6ES7 195-0BG00-0XA0 6ES7 195-0BG10-0XA0 6ES7 195-0BG20-0XA0 6ES7 195-0BG30-0XA0 6ES7 195-0BG40-0XA0	ASIC SIM 1-2 For connection according to IEC H1 for PROFIBUS PA with a transmission rate of 31.25 kbit/s <ul style="list-style-type: none"> • 60 units (in tube) • 1000 units (tape & reel)
ASIC FOCSI Fiber Optic Controller from Siemens for conditioning signals for the optical PROFIBUS <ul style="list-style-type: none"> • 40 units (lead-free) 	6ES7 195-0EA20-0XA0	Accessories Firmware for Siemens ASIC SPC 3 <ul style="list-style-type: none"> • DP firmware • DPV1 firmware • DPV1 firmware upgrade
		Firmware for Siemens ASIC DPC 31 <ul style="list-style-type: none"> • DPV1 firmware

SIMATIC ET 200 distributed I/O

PROFIBUS components

Connections/interfaces

Overview

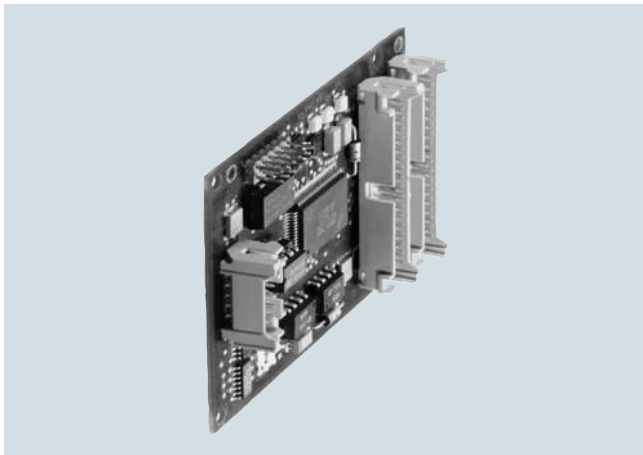

- PC slave board IM 182-1 for the connection of AT-compatible PCs as DP slaves

Technical specifications

6ES7 182-0AA01-0XA0	
General information	
Application area	Slave applications
Supply voltage	
5 V DC	Yes
Input current	
Current consumption, typ.	250 mA
Hardware components/ modules/ ASIC	
ASIC	SPC 3
Scope of firmware	4 to 24 KB (incl. test program)
Programming devices	
Microprocessor type	Processor of the PG/PC
Interfaces	
PROFIBUS DP	
• Transmission rate, max.	12 Mbit/s
Protocols	
PROFIBUS DP	Yes
Ambient conditions	
Operating temperature	
• Min.	0 °C
• max.	60 °C
Dimensions	
PCB size, width	168 mm
PCB size, height	105 mm

Ordering data

Order No.

SIMATIC S5/S7 IM 182-1 PC slave board	6ES7 182-0AA01-0XA0
For PROFIBUS DP, max. 12 Mbit/s	
Accessories	
Firmware for Siemens ASIC SPC 3 and IM 182-1	
• DP firmware	6ES7 195-2BA00-0XA0
• DPV1 firmware	6ES7 195-2BA01-0XA0
• DPV1 firmware upgrade	6ES7 195-2BA02-0XA0

SIMATIC ET 200 distributed I/O

SIPLUS PROFIBUS components for ET 200

SIPLUS diagnostic repeater for PROFIBUS

Overview



- RS-485 repeater with online line diagnostics for PROFIBUS DP
- PROFIBUS DP standard slaves (DP-V1)
- Automatic determination of fault type and location
- Transmission rate from 9.6 kbit/s to 12 Mbit/s
- Connection via Fast Connect IDC

Note:

SIPLUS extreme products are based on Siemens Industry standard products. The contents listed here were taken from the respective standard products. SIPLUS extreme specific information was added.

SIPLUS diagnostics repeater for PROFIBUS DP

Order No.	6AG1 972-0AB01-4XA0
Order No. based on	6ES7 972-0AB01-0AA0
Ambient temperature range	0 °C ... +60 °C
Conformal coating	Coating of the printed circuit boards and the electronic components
Technical data	The technical data of the standard product applies except for the environmental conditions.
Ambient conditions	
Relative humidity	100%, condensation/frost permissible. No commissioning if condensation present.
Biologically active substances, compliance with EN 60721-3-3	Class 3B2 mold and fungal spores (excluding fauna). The supplied plug covers must remain in place over the unused interfaces during operation!
Chemically active substances, compliance with EN 60721-3-3	Class 3C4 incl. salt spray in accordance with EN60068-2-52 (degree of severity 3). The supplied plug covers must remain in place over the unused interfaces during operation!
Mechanically active substances, compliance with EN 60721-3-3	Class 3S4 incl. sand, dust. The supplied plug covers must remain in place over the unused interfaces during operation!
Air pressure (depending on the highest positive temperature range specified)	1 080 ... 795 hPa (-1 000 ... +2 000m) see ambient temperature range 795 ... 658 hPa (+2 000 ... +3 500m) derating 10 K 658...540 hPa (+3 500 ... +5 000 m) derating 20 K

For technical documentation on SIPLUS, see:
<http://www.siemens.com/siplus-extreme>

Ordering data	Order No.
SIPLUS RS 485 diagnostics repeater (medial exposure) to connect up to 2 segments to PROFIBUS DP, with on-line diagnostics functions to monitor the bus lines	6AG1 972-0AB01-4XA0
Accessories	See SIMATIC RS 485 diagnostics repeater, page 9/337

SIMATIC ET 200 distributed I/O

PROFINET components

Enhanced Real-Time Ethernet Controller ERTEC

Overview

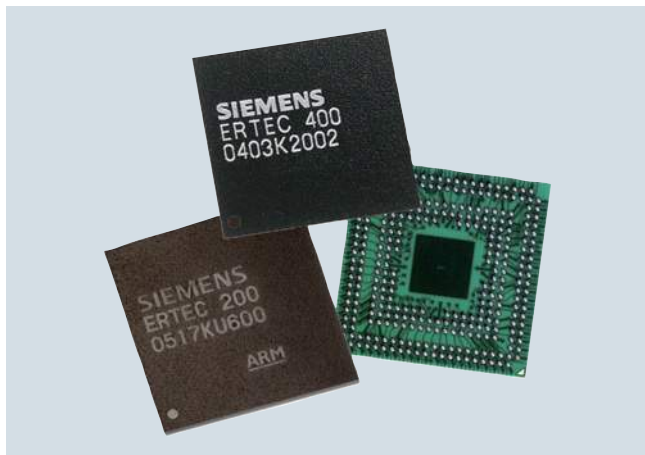

With the Industrial Ethernet ASICs of the ERTEC family (Enhanced Real-Time Ethernet Controller), devices and systems can be connected to PROFINET without great effort. The high-performance Ethernet controllers with 32-bit microprocessor as well as integral real-time switch for Real Time Ethernet have been specially developed for industrial use.

These Ethernet controllers handle all the data transmission for PROFINET with Real-Time (RT) and Isochronous Real-Time (IRT) and thus offload the application processor. Thanks to the integral 2-port switch (ERTEC 200) or 4-port switch (ERTEC 400), there are no costs for external switches. Flexible topologies such as star, tree and linear topologies can be implemented without any other external network components.

- ERTEC 200 with an integral 2-port switch for developing compact or modular PROFINET field devices. It also contains integral PHYs for linking the Ethernet controllers to the physical communication network.
- ERTEC 400 with 4 integral ports and one integral PCI interface for developing network components and field devices with high requirements regarding communication capabilities.

The DK-ERTEC 200 PN IO and DK-ERTEC 400 PN IO Development Kits enable the uncomplicated development of PROFINET field devices thanks to fast and simple integration of the PROFINET IO functionalities based on the ERTEC. The ERTEC 200 PN IO Starter Kit is especially suitable for low-cost introduction to PROFINET field device development.

Technical specifications

	ERTEC 400	ERTEC 200
Transmission rate	10/100 Mbit/s	10/100 Mbit/s
Interfaces		
• Ethernet / PHY interface	4 x PHY interface <ul style="list-style-type: none"> • Half/full duplex • Broadcast filter • IEEE 802.1 p Traffic Management • IEEE 802.1 q VLAN Tagging and Identification • IEEE 1588 Support for copper and fiber-optic cables; autosensing; autocrossover	2 x Ethernet interface (PHY integrated) or alternatively 2 x PHY interface (for connection of optical PHYs) <ul style="list-style-type: none"> • Half/full duplex • Broadcast filter • IEEE 802.1 p Traffic Management • IEEE 802.1 q VLAN Tagging and Identification • IEEE 1588 Support for copper and fiber-optic cables (PHY for copper integrated); autosensing; autocrossover
- In connection with the corresponding PHY types:		
• Local Bus Unit (LBU)	Local bus master interface for connecting an external host with access to internal areas of the ERTEC; 16 bit data bit width	Local bus master interface for connecting an external host with access to internal areas of the ERTEC; 16 bit data bit width
• PCI interface	32 bit, 33/66 MHz <ul style="list-style-type: none"> • Host functionality • 2 PCI interrupt outputs INTA_N and SERR_N • Power Management V1.1 • 3.3 V (5 V tolerance) • PCI master/target interface • PCI Core compatible PCI spec. 2.2 	–
• External memory interface (EMIF)		
- SDRAM controller	128 MB/16 bit or 256 MB/32 bit	64 MB/16 bit or 128 MB/32 bit
- SRAM controller	4 x 16 MB for asynchronous blocks (SRAM, flash, I/O 8/16/32 bit)	4 x 16 MB for asynchronous blocks (SRAM, flash, I/O 8/16/32 bit)
- Chip-select support	yes	yes
• IO interfaces	32 parameterizable I/O (GPIO); multifunctional outputs	45 parameterizable I/O (GPIO); multifunctional outputs

Technical specifications (continued)

	ERTEC 400	ERTEC 200
Function units		
<ul style="list-style-type: none"> Real-time Ethernet switch 	Integral 4-port Fast Ethernet/Real-Time Ethernet switch; 10/100 Mbit Ethernet full duplex 192 KB	Integral 2-port Fast Ethernet/Real-Time Ethernet switch; 10/100 Mbit Ethernet full duplex 64 KB
<ul style="list-style-type: none"> Communications RAM (SRAM on chip for message frame buffering) Intelligent switching and PROFINET IRT prioritization/timing 	yes	yes
<ul style="list-style-type: none"> Integral ARM946 processor Adjustable operating frequency Data cache Instruction cache D-TCM Memory Protection Unit (MPU) Trace functionality Interrupt controller 	32-bit ARM system 50/100/150 MHz 4 KB 8 KB 4 KB yes Debug capability due to embedded ICE (JTAG) For 16xIRQ/ 8xFIQ	32-bit ARM system 50/100/150 MHz 4 KB 8 KB 4 KB yes Debug capability due to embedded ICE (JTAG) For 16xIRQ/ 8xFIQ
<ul style="list-style-type: none"> Processor I/O SPI master interface Timer 32 bit down-counter F timer 32 bit down-counter Watchdog functions External interrupt inputs 	2 UART similar to the standard UART 16C550 yes 2 yes 2 yes	1 UART similar to the standard UART 16C550 yes 3 yes 3 yes
<ul style="list-style-type: none"> Internal bus structure 	32 bit (multi-layer AHB) with 50 MHz clock frequency; multi-layer architecture with parallel access structure of several multimasters to multislave	32 bit (multi-layer AHB) with 50 MHz clock frequency; multi-layer architecture with parallel access structure of several multimasters to multislave
<ul style="list-style-type: none"> SRAM-integral work memory on AHB Size Program/data memory Multiport RAM 	8 KB ARM 946 For ARM946, IRT and PCI	– – –
<ul style="list-style-type: none"> Clock cycle generation 	Internal through PLL for ARM 946ES, AHB, APB and IRT	Internal through PLL for ARM 946ES, AHB, APB and IRT
<ul style="list-style-type: none"> Boot ROM 	With opcode for software download from different download sources	With opcode for software download from different download sources
<ul style="list-style-type: none"> Test functions 	Boundary scan	Boundary scan
Supply voltage		
<ul style="list-style-type: none"> Core (VDD Core) I/Os (VDD IO) 	1.5 V +/- 10 % 3.3 V +/- 10 %	1.5 V +/- 10 % 3.3 V +/- 10 %
Current input		
<ul style="list-style-type: none"> IDD core IDD IO 	Typ. 270 mA Typ. 150 mA	Typ. 535 mA Typ. 175 mA
Power loss		
<ul style="list-style-type: none"> PDD core PDD IO 	Typ. 0.4 W Typ. 0.5 W	Typ. 0.8 W Typ. 0.57 W
Perm. ambient conditions		
<ul style="list-style-type: none"> Operating temperature Transport/storage temperature Relative humidity 	-40 °C to +85 °C -40 °C to +85 °C Max. 95 % at +25 °C	-40 °C to +85 °C -40 °C to +85 °C Max. 95 % at +25 °C
Constructional design		
<ul style="list-style-type: none"> Housing Pinning Ball Pitch 	Plastic FBGA 304 Pin 0.8 mm	Plastic FBGA 304 Pin 0.8 mm
Dimensions (W x H x D) in mm	19 x 1 x 19	19 x 1 x 19
- ERTEC		
Supported communications protocols		
<ul style="list-style-type: none"> General Ethernet protocols 	In accordance with the respective software implementation that uses the ERTEC as Ethernet controller	In accordance with the respective software implementation that uses the ERTEC as Ethernet controller
<ul style="list-style-type: none"> PROFINET in combination with a PROFINET Software Stack 	Real-Time communication (RT); Isochronous Real-Time communication (IRT)	Real-Time communication (RT); Isochronous Real-Time communication (IRT)

SIMATIC ET 200 distributed I/O

PROFINET components

Enhanced Real-Time Ethernet Controller ERTEC

Ordering data	Order No.	Ordering data	Order No.
ERTEC 400 (lead-free) ASIC ERTEC 400 for connection to switched Ethernet 10/100 Mbit/s, Ethernet controller with integrated 4-port switch, ARM 946 RISC and PCI interface (V2.2), data preparation for real-time and isochrone real-time for PROFINET IO <ul style="list-style-type: none"> • 70 units (individual tray), • 350 units (drypack, 5 trays), 	6GK1 184-0BB01-0AA1 6GK1 184-0BB01-0AA2	ERTEC 200 (lead-free) ASIC ERTEC 200 for connection to switched Ethernet 10/100 Mbit/s, Ethernet controller with integrated 2-port switch, ARM 946 processor and integrated PHYs real-time for PROFINET IO <ul style="list-style-type: none"> • 70 units (individual tray), • 350 units (drypack, 5 trays), • 3500 units (package, 10 drypacks) 	6GK1 182-0BB01-0AA1 6GK1 182-0BB01-0AA2 6GK1 182-0BB01-0AA3
Development kit DK-ERTEC 400 PN IO	6GK1 953-0CA00	Development Kit DK-ERTEC 200 PN IO	6GK1 953-0BA00
		ERTEC 200 PN IO Starter Kit	6ES7 195-3BD00-0YA0

SIMATIC ET 200 distributed I/O PROFINET components

Development kit for ERTEC

Overview



With the development packages for PROFINET, compact or modular PROFINET field devices can be developed quickly and with little effort. Depending on the application, different development packages are available.

The development packages for the ASICs of the ERTEC family (Enhanced Real-Time Ethernet Controller) are suitable for the development of field devices with an integrated IRT switch (Isochronous Real-Time). The demand for real-time capability, linear topology capability, and for IT integration is therefore met perfectly.

With the help of the development package for standard Ethernet controllers, PROFINET devices can be developed on the basis of a standard Ethernet controller. Devices with RT (Real-Time) can be implemented in the field device without special hardware.

The PROFIsafe StarterKit permits the implementation of fail-safe devices. In so doing, the PROFIsafe Stack applicatively builds on the PROFINET stack.

Ordering data

Order No.

ERTEC development kits

Development kit
DK-ERTEC 200 PN IO

6GK1 953-0BA00

Development kit
DK-ERTEC 400 PN IO

6GK1 953-0CA00

ERTEC 200 PN IO Starter Kit

6ES7 195-3BD00-0YA0

Development kit for standard
Ethernet controller

6ES7 195-3BC00-0YA0

PROFIsafe starter kit V3.4

6ES7 195-3BF02-0YA0

ERTEC ASICs

ERTEC 200

ASIC ERTEC 200 for connection to switched Ethernet 10/100 Mbit/s, Ethernet controller with integrated 2-port switch, ARM 946 processor and integrated PHYs real-time for PROFINET IO

- 70 units (individual trays),
- 350 units (drypack, 5 trays),
- 3500 units (package, 10 drypacks)

6GK1 182-0BB01-0AA1

6GK1 182-0BB01-0AA2

6GK1 182-0BB01-0AA3

ERTEC 400

ASIC ERTEC 400 for connection to switched Ethernet 10/100 Mbit/s, Ethernet controller with integrated 4-port switch, ARM 946 RISC and PCI (V2.2), data preparation for real-time and isochronous real-time for PROFINET IO

- 70 units (individual trays),
- 350 units (drypack, 5 trays),

6GK1 184-0BB01-0AA1

6GK1 184-0BB01-0AA2

Accessories

PROFINET IO product line license
for one product line

6ES7 195-3BC10-0YA0

SIMATIC ET 200 distributed I/O

Network components for PROFIBUS

Repeater RS 485 for PROFIBUS

Overview



- Automatic detection of transmission rates
- Transmission rates from 9.6 kbit/s to 12 Mbit/s are possible, incl. 45.45 kbit/s
- 24 V DC voltage display
- Indication of bus activity segment 1 and 2
- The separation of segment 1 and segment 2 by means of switches is possible
- Separation of the right segment with an inserted terminating resistor
- Decoupling of segment 1 and segment 2 in the case of static interference

Designed for Industry

- For increasing the expansion
- Electric isolation of segments
- Commissioning support
 - Switches for separation of segments
 - Bus activity display
 - Segment separation in the case of an incorrectly inserted terminating resistor

In this context, please also note the diagnostics repeater that provides extensive diagnostics functions for physical line diagnostics in addition to the normal repeater functionality. This is described in "Distributed I/O / diagnostics / diagnostics repeater for PROFIBUS DP".

Technical specifications

6ES7 972-0AA02-0XA0	
Supply voltage	
24 V DC	Yes
permissible range, lower limit (DC)	20.4 V
permissible range, upper limit (DC)	28.8 V
Input current	
Current consumption, max.	100 mA; (100 mA without loads at PG/OP socket; 130 mA load at PG/OP socket (5 V/90 mA); 200 mA load at PG/OP socket (24 V/100 mA))
Interfaces	
Bus cables	2 terminal blocks
PROFIBUS DP	
• Transmission rate, max.	12 Mbit/s; 9.6 kbit/s to 12 Mbit/s
Degree and class of protection	
IP20	Yes
Ambient conditions	
Operating temperature	
• Min.	0 °C
• max.	60 °C
Storage/transport temperature	
• Min.	-40 °C
• max.	70 °C
Relative humidity	
• Operation, max.	95 %; at 25 °C
Connection method	
Power supply	Terminal block
Dimensions	
Width	45 mm
Height	128 mm
Depth	67 mm
Weight	
Weight, approx.	350 g

Ordering data

RS 485 repeater for PROFIBUS
Transfer rate up to max. 12 Mbit/s,
24 V DC, enclosure IP20

Order No.

6ES7 972-0AA02-0XA0

SIMATIC ET 200 distributed I/O

Network components for PROFIBUS

Active RS 485 terminating element

Overview



- Terminates bus segments at data transmission rates of 9.6 kbit/s to 12 Mbit/s
- Power supply independent of bus stations.

Designed for Industry

- Terminal-independent bus termination through onboard power supply

Technical specifications

6ES7 972-0DA00-0AA0	
Supply voltage	Yes
24 V DC	
permissible range, lower limit (DC)	20.4 V
permissible range, upper limit (DC)	28.8 V
Input current	
Current consumption, typ.	30 mA
Interfaces	
Bus cables	Screw terminal block
PROFIBUS DP	
• Transmission rate, max.	12 Mbit/s; 9.6 kbit/s to 12 Mbit/s
Degree and class of protection	
IP20	Yes
Ambient conditions	
Operating temperature	
• Min.	0 °C
• max.	60 °C
Storage/transport temperature	
• Min.	-40 °C
• max.	70 °C
Relative humidity	
• Operation, max.	95 %; at +25 °C
Connection method	
Power supply	Screw terminal block
Dimensions	
Width	60 mm
Height	70 mm
Depth	43 mm
Weight	
Weight, approx.	95 g

Ordering data

Order No.

Active RS 485 terminating element for PROFIBUS

6ES7 972-0DA00-0AA0

to complete bus segments for transmission rates of 9.6 kbit/s to 12 Mbit/s

SIMATIC ET 200 distributed I/O

SIPLUS network components for PROFIBUS

SIPLUS RS 485 repeater

Overview



- Automatically detects transmission rate
- 45.45 kbit/s transmission rate is possible
- 24 V DC voltage display
- Bus activity segment 1 and 2 display
- The separation of segment 1 and segment 2 on switch is possible
- Separation of the right segment with an inserted terminator
- Decoupling of segment 1 and segment 2 with static interference

Designed for Industry

- To increase the number of participants and the extension
- Segment electric isolation
- Commissioning support
 - Segment separation switch
 - Bus activity display
 - Segment separation with an incorrectly inserted terminator

Please also note in this context the diagnostics repeater that provides extensive diagnostics functions for physical line diagnostics in addition to the normal repeater functionality. This is described in "Distributed I/O / diagnostics / diagnostics repeater for PROFIBUS DP".

Note:

SIPLUS extreme products are based on Siemens Industry standard products. The contents listed here were taken from the respective standard products. SIPLUS extreme-specific information was added.

SIPLUS RS 485 repeater for PROFIBUS

Order No.	6AG1 972-0AA02-7XA0
Order No. based on	6ES7 972-0AA02-0XA0
Ambient temperature range	-25 °C ... +70 °C
Conformal coating	Coating of the printed circuit boards and the electronic components
Technical data	The technical data of the standard product applies except for the ambient conditions.
Ambient conditions	
Relative humidity	100%, condensation/frost permissible. No commissioning if condensation present.
Biologically active substances, compliance with EN 60721-3-3	Class 3B2 mold spores, fungal spores (excluding fauna). The supplied plug covers must remain in place over the unused interfaces during operation!
Chemically active substances, compliance with EN 60721-3-3	Class 3C4 incl. salt spray in accordance with EN60068-2-52 (degree of severity 3). The supplied plug covers must remain in place over the unused interfaces during operation!
Mechanically active substances, compliance with EN 60721-3-3	Class 3S4 incl. sand, dust. The supplied plug covers must remain in place over the unused interfaces during operation!
Air pressure (depending on the highest positive temperature range specified)	1,080...795 hPa (-1,000 ... +2,000 m) See ambient temperature range 795...658 hPa (+2,000 ... +3,500 m) Derating 10 K 658...540 hPa (+3500 ... +5000m) Derating 20K

For further technical documentation on SIPLUS, see:
<http://www.siemens.com/siplus-extreme>

Ordering data

Order No.

SIPLUS RS 485 repeater for PROFIBUS

For temperature range -25 °C to +70 °C and use under medial exposure (e.g. sulfur chloride atmosphere)

Transfer rate up to max. 12 Mbit/s, 24 V DC, enclosure IP20

6AG1 972-0AA02-7XA0

SIMATIC ET 200 distributed I/O

SIPLUS network components for PROFIBUS

SIPLUS DP active RS485 terminating element

Overview



- Used to complete bus segments at rates of 9.6 kbit/s to 12 Mbit/s
- Power supply independent of the bus participants.

Designed for Industry

- End-device independent bus termination due to own power supply

Note:

SIPLUS extreme products are based on Siemens Industry standard products. The contents listed here were taken from the respective standard products. SIPLUS extreme specific information was added.

SIPLUS active RS-485 terminating element

Order No.	6AG1 972-0DA00-2AA0
Order No. based on	6ES7 972-0DA00-0AA0
Ambient temperature range	-25 °C ... +60 °C
Conformal coating	Coating of the printed circuit boards and the electronic components
Technical data	The technical data of the standard product applies except for the ambient conditions.
Ambient conditions	
Relative humidity	100%, condensation/frost permissible. No commissioning if condensation present.
Biologically active substances, compliance with EN 60721-3-3	Class 3B2 mold and fungal spores (excluding fauna). The supplied plug covers must remain in place over the unused interfaces during operation!
Chemically active substances, compliance with EN 60721-3-3	Class 3C4 incl. salt spray in accordance with EN60068-2-52 (degree of severity 3). The supplied plug covers must remain in place over the unused interfaces during operation!
Mechanically active substances, compliance with EN 60721-3-3	Class 3S4 incl. sand, dust. The supplied plug covers must remain in place over the unused interfaces during operation!
Air pressure (depending on the highest positive temperature range specified)	1,080...795 hPa (-1,000 ... +2,000 m) See ambient temperature range 795...658 hPa (+2,000 ... +3,500 m) Derating 10 K 658...540 hPa (+3 500 ... +5 000m) Derating 20K

For technical documentation on SIPLUS, see:
<http://www.siemens.com/siplus-extreme>

Ordering data

Order No.

SIPLUS active RS 485 terminating element for PROFIBUS

6AG1 972-0DA00-2AA0

(extended temperature range and medial exposure)

to complete bus segments for transmission rates of 9.6 kbit/s to 12 Mbit/s

SIMATIC ET 200 distributed I/O

Network transitions

PN/PN coupler

Overview



- Maximum data exchange of 256-byte input data and 256-byte output data between two PROFINET networks
- Maximum of 16 input/output ranges for the exchange of data
- Electrical isolation between the two PROFINET IO subnets
- Redundant power supply
- Supported Ethernet services
 - ping
 - arp
 - network diagnostics (SNMP/MIB-2)
- Diagnostic interrupts
- ReturnOfSubmodule interrupts

Ordering data

Order No.

PN/PN coupler

for connecting two PROFINET networks

6ES7158-3AD01-0XA0

Power supply connector

Spare part;
for connecting the 24 V DC supply voltage

- with push-in terminals
- with screw-type terminals

6ES7 193-4JB00-0AA0
6ES7 193-4JB50-0AA0

SIMATIC ET 200 distributed I/O

Network transitions

DP/DP coupler

Overview



- Interconnecting two PROFIBUS DP networks
- The interchange of data between both DP networks takes place by internal copying in the coupler.

Technical specifications

DP/DP transceiver	
PROFIBUS transmission rate	max. 12 Mbit/s
Interfaces	
• PROFIBUS DP	9-pin Sub-D connector
Supply voltage	24 V DC
Current consumption typ.	150 mA
Mounting	Upright (DIP switches above)
Perm. environmental conditions	
• Operating temperature	
- horizontal mounting	0°C ... +60°C
- all other mounting positions	0°C ... +40°C
• Transport/storage temperature	-40 °C ... +70 °C
• Relative humidity	10-95 % at +25 °C
Design	
• Dimensions (W x H x D) in mm	40 x 127 x 117
• Weight	approx. 250 g
Degree of protection	IP20

Ordering data

Order No.

DP/DP coupler

6ES7 158-0AD01-0XA0

Note:

The manual is available free on the Internet.

SIMATIC ET 200 distributed I/O

Notes

9

SIMATIC control systems



- 10/2 SIMATIC TDC multiprocessor control system**
- 10/2 UR5213 rack
- 10/3 CPU551 processor module
- 10/4 MC5xx program memory module
- 10/4 CP50M1 communications module
- 10/5 CP51M1 communications module
- 10/5 CP53M0 communications module
- 10/6 SM500 I/O Module
- 10/8 GlobalDataMemory
- 10/9 Accessories for SIMATIC TDC

SIMATIC Control Systems

SIMATIC TDC multiprocessor control system

UR5213 rack

Overview



The UR5213 rack is the basis for SIMATIC TDC. System power supply and system fan are integrated. A high-performance 64-bit backplane bus supports high-speed data exchange between the inserted modules.

SR51 slot cover

The slot cover SR51 is used for covering any slots that are not used in the rack. It is required to ensure the EMC properties and ventilation of the system.



SR51 slot cover

Technical specifications

Input voltage range	85 V - 264 V AC, 47 - 63 Hz 198 V - 253 V DC
Mains buffering	Min. 20 ms
Dimensions (W x H x D) in mm	482.6 x 354.9 x 343
Weight	Approx. 20 kg
Degree of protection	IP20
Rated input current	At 120 V AC: 4.45 A At 230 V AC: 2.3 A At 220 V DC: 2.38 A
Max. inrush current	<40 A
Output voltages	+3.3 V 44 A + 5 V 36 A + 12 V 4.6 A - 12 V 4 A
Operating temperature range	0 °C to +60 °C
Storage temperature range	-40 °C to +70 °C

Ordering data

Order No.

**UR5213 rack,
spare-part compatible successor
of 6DD1 682-0CH0**

6DD1 682-0CH2

Accessories

SR51 slot cover

for covering any slots that are not
used in the rack

6DD1 682-0DA1

Spare parts

Backup battery

6ES7 971-0BA00

SIMATIC Control Systems

SIMATIC TDC multiprocessor control system

CPU551 processor module

Overview

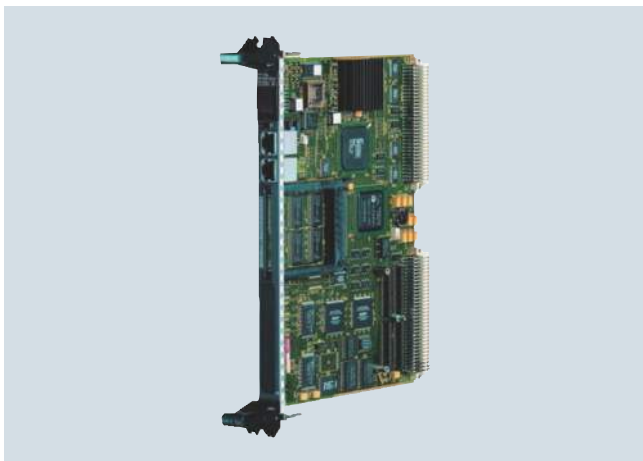

High-performance CPU module for open and closed-loop control and arithmetic tasks.

Technical specifications

CPU551	
Required space / width	1 slot
Weight	0.6 kg
Display	5x7 LED
Local service interface	Serial RS232 interface
Sampling intervals	from 100 µs
SDRAM	128 MB
Synchronous cache	8 MB
Clock frequency	500 MHz
CPU	64 Bit RISC CPU with floating point unit
SRAM	512 KB, battery buffered
Power supply	
Voltage / Power supply (at 250°C)	+3.3 V, 2.0 A typical +5 V, 1.5 A typical +12 V, 0.04 A typical -12 V, 0.04 A typical
Buffer battery	3.0 V, 3 µA typical
Power loss, typical	15 W
Digital inputs	
Number	8 inputs, 4 with alarm capability
Galvanic isolation	Only through optional interface modules
Input voltage	24 V
• Rated voltage	
• For 0-signal	-1 V ... +6 V
• For 1-signal	+13.5 V ... +33 V
Input power	
• At 0-signal	0 mA
• At 1-signal	3 mA
Delay time	100 µs
Real-time clock, resolution	0.1 ms

Ordering data

Order No.

CPU551 processor module	6DD1 600-0BA2
Accessories	
MC500 memory module 4 MB	6DD1 610-0AH4
MC510 memory module 8 MB	6DD1 610-0AH6
MC521 memory module 2 MB	6DD1 610-0AH3
SB10 interface module for connecting 8 digital I/O to FM 458-1 DP	6DD1 681-0AE2
SB60 interface module for connecting 8 digital inputs to FM 458-1 DP, input voltage 115/230 V DC/AC	6DD1 681-0AF4
SB61 interface module for connecting 8 digital I/O to FM 458-1 DP, input voltage 24/48 V DC	6DD1 681-0EB3
SU12 interface module for connecting 10 signals to FM 458-1 DP	6DD1 681-0AJ1
SC66 interface cable between the CPU551 and the SB10, SB60, SB61 or SU12 interface module, 2 m long	6DD1 684-0GG0
SC67 service cable between CPU551 and PG/PC, 7 m long	6DD1 684-0GH0

SIMATIC Control Systems

SIMATIC TDC multiprocessor control system

MC5xx program memory module
CP50M1 communications module

Overview MC5xx program memory module

Program memory module for the program designed with CFC.

Ordering data

Order No.

MC500 memory module (4 MB)	6DD1 610-0AH4
MC510 memory module (8 MB)	6DD1 610-0AH6
MC521 memory module (2 MB)	6DD1 610-0AH3

Overview CP50M1 communications module



The CP50M1 communications module provides two PROFIBUS DP/MPI interfaces and an 8 MB interprocessor memory for inter-CPU communication. The interfaces can be used as PROFIBUS DP master, slave, as master and slave simultaneously or as MPI node.

Technical specifications

Power supply

Voltage / Power supply	+5 V, 1.0 A typical
Power loss, typical	5 W
Required space / width	1 slot
Weight	0.34 kg

Ordering data

Order No.

CP50M1 communications module with 8 MB interprocessor memory, with up to 1 MPI interface and up to 2 PROFIBUS DP interfaces	6DD1 661-0AD1
---	----------------------

SIMATIC Control Systems

SIMATIC TDC multiprocessor control system

CP51M1 communications module
CP53M0 communications module

Overview CP51M1 communications module

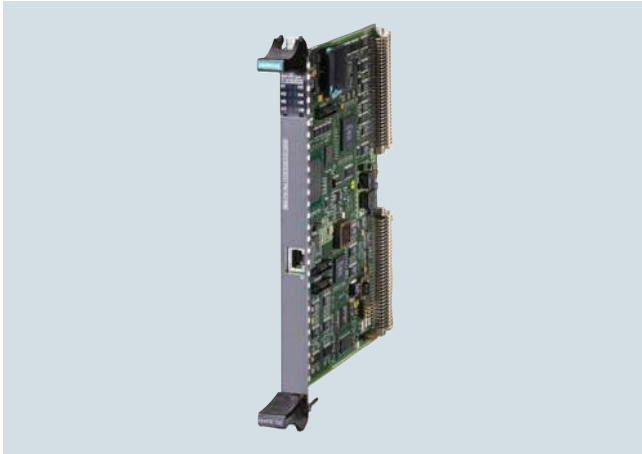

The CP51M1 communications module is an Industrial Ethernet interface for the SIMATIC TDC automation system.

Overview CP53M0 communications module



The CP53M0 communications module allows coupling of a SIMATIC TDC system to a SIMADYN D system for fast data exchange, e.g. when expanding existing SIMADYN D systems.

Technical specifications

Up-to-date technical specifications can be taken from the user documentation provided at the start of delivery

Required space / width	1 slot
Weight	
Connection for Industrial Ethernet	RJ45
Protocols	TCP/IP and/or UDP
Message frame lengths	also larger than 2 KB
Modes of transfer	Refresh, Handshake, Multiple and Select
Autosensing	for 10 Mbit or 100 Mbit network
Default router	adjustable
Power supply	
Voltage / power supply (max. values)	
Power loss, typical	

Ordering data

Ordering data	Order No.
CP51M1 communications module	6DD1 661-0AE1

Technical specifications

Memory	
Communication memory	SRAM, 128 KB
Communications buffer	SDRAM, 8 MB
FOC interface	
Number	2 (master mode) 1 (slave mode)
Data transfer rate	96 Mbit/s
Coding	5B/6B
Voltage, currents	
Voltages / currents	+5 V / 0.3 A 3.3 V / 0.5 A
Power loss	
Power loss, typical	3.1 W
Dimensions	
Number of slots required in rack	1
Dimensions W x H x D (in mm)	20 x 233 x 160
Weight	0.6 kg

Ordering data

Ordering data	Order No.
CP53M0 communications module For connection of a SIMATIC TDC system to a SIMADYN D system or to two further SIMATIC TDC racks	6DD1 660-0BJ0

SIMATIC Control Systems

SIMATIC TDC multiprocessor control system

SM500 I/O module

Overview

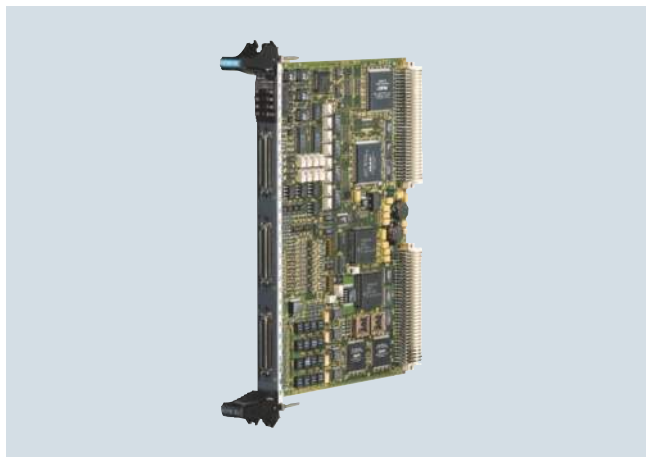

The SM500 I/O module provides analog and digital inputs/outputs as well as incremental and absolute value encoder connections.

Technical specifications

Power supply

Voltage/current supply (at 25°C)	+5 V typ. 1.0 A +3.3 V typ. 0.05 A +12 V typ. 0.3 A -12 V typ. 0.3 A
Typical power loss	12.5 W
Space requirement/width	1 slot
Weight	0.7 kg

Analog outputs

Number	8
Version	Output with associated ground
Electrical isolation	No
Output voltage range	-10 V to +10 V
Output current	± 10 mA
Resolution	12 bit
Typ. conversion time per channel	4 µs
Accuracy	
• Max. differential linearity error	± 1 LSB (monotony maintained)
• Max. gain error	± 0.3 %
• Max. offset error	± 24 LSB
Slewrate	Approx. 3.5 V/µs
Voltage output	
• Short-circuit protection to ground	Yes
• Short-circuit current	Appr. 100 mA

Analog inputs

Number	8
Version	Differential inputs
Electrical isolation	No
Input voltage range	-10 V to +10V
Resolution	12 bit
Max. conversion time per channel	Approx. 20 µs
Accuracy	
• Max. differential linearity error	± 1 LSB (no missing code)
• Max. gain error	± 0.3 %
• Max. offset error	± 5 LSB
Input resistance	20 kOhm
Input filter	34 kHz
Incorrect polarity protection	Yes, as differential inputs are used

Integrating analog inputs (V/Hz)

Number	4
Version	Differential inputs
Electrical isolation	No
Input voltage range	-10 V to +10 V
Resolution	Dependent on the integration time, e.g. 15 bits for a 4 ms integration time
Max. integration time per channel	Can be configured
Accuracy	
• Max. differential linearity error	0.05 %
• Max. gain error	1 %
• Max. offset error	± 2 LSB (software calibration)
Input resistance	470 kOhm
Input filter	2 kHz
Incorrect polarity protection	Yes, as differential inputs are used

Digital outputs

Number	16
Electrical isolation	Only by using the optional interface modules
External power supply voltage	
• Rated value	24 V
• Permissible range	20 to 30
• Briefly	35 V, for max. 0,5 s
• Max. current consumption (without load)	40 mA
Output voltage range	
• For a 0-signal, max.	3 V
• For a 1-signal, min.	Ext. power supply voltage. - 2.5 V
Output current	
• For a 0-signal, min.	- 20 µA
• For a 1-signal	
- Rated value	50 mA
- Permissible range, max.	100 mA
Delay time	100 µs
Max. switching frequency of the outputs for an ohmic load	6 kHz
Short-circuit protection to	
• Ground	Yes
• Ext. power supply	No
Max. short-circuit current	250 mA

Technical specifications (continued)

Summed current of the outputs (to 60 °C)	16 x 50 mA
Limiting of inductive switch-off voltages	External power supply voltage + 1 V
Digital inputs	
Number	16, non-floating
Electrical isolation	Only by using the optional interface modules
Input voltage	
• Rated voltage	24 V
• For a 0 – signal	-1 V to +6 V
• For a 1 – signal	+13.5 V to +33 V
Input current	
• For a 0 – signal	0 mA
• For a 1 – signal	3 mA
Delay time	0.1 ms
Incremental encoder	
Number of encoders	4
Types which can be connected	Incremental encoder with tracks offset through 90° degrees
Version	Differential inputs, can be changed-over between 15 V (HTL) and 5 V (TTL) encoder signals
Track signals	Track A, B with or without zero pulse N
Min. phase difference of the track signals	200 ns
Max. pulse frequency (track frequency)	1 MHz
Input voltage	
• 15 V encoder	
- Rated value	- 30 V to + 30 V
- For a 0-signal	- 30 V to + 4 V
- For a 1-signal	+ 8 V to +30 V
• 5 V encoder	
- Rated value	- 7 V to + 7 V
- For a 0-signal	- 7 V to - 0,7 V
- For a 1-signal	+ 1.5 V to + 7 V
Input current	
• For 15 V - encoder (typ.,abs.)	5,0 mA
• For 5 V - encoder (typ.,abs.)	1.5 mA

Monitoring output	Not available
Monitoring input	Specification, the same as for digital inputs
Interrupt reset output	
• Short-circuit protection to ground	Yes
- Ext. power supply	No
- Max. short-circuit current	20 mA
Interrupt input	
• Input voltage (permissible range)	0 V to 5 V
- 0-signal, max.	< 0,5 V
- 1-signal, min.	> 2.0 V
• Input current	
- 0-signal	- 2.8 mA
- 1-signal	1.6 mA
Power supply voltage for encoders	
Number	1
Electrical isolation	No
Typ. output voltage	13.5 V
Max. output current	150 mA, short-circuit proof to ground, short-circuit current, approx. 250 mA
Absolute value encoder inputs	
Number	4
Version	Differential inputs, RS 485 signal level
Signal voltage	5 V, RS485 level
Types which can be connected	Single or multi-turn Encoder
Protocols	SSI, EnDat
Data formats	Gray, binary
Data direction	
• Uni-directional	SSI
• Bi-directional	EnDat
Data bits	SSI: 13+Parity, 25+Parity EnDat: variable
Max. pulse frequency	2 MHz, dependant on the cable length
Input voltage	
• Permissible range	RS 485 signal level

Ordering data

	Order No.
SM500 I/O module	6DD1 640-0AH0
SB10 interface module	6DD1 681-0AE2
for connecting 8 digital I/O to FM 458-1 DP	
SB60 interface module	6DD1 681-0AF4
for connecting 8 digital inputs to FM 458-1 DP, input voltage 115/230 V DC/AC	
SB61 interface module	6DD1 681-0EB3
for connecting 8 digital I/O to FM 458-1 DP, input voltage 24/48 V DC	
SB70 interface module	6DD1 681-0AG2
8 digital outputs with relays	
SB71 interface module	6DD1 681-0DH1
8 digital outputs with transistors, 24/48 V DC	

	Order No.
SU12 interface modul	6DD1 681-0AJ1
for connecting 10 signals to FM 458-1 DP	
SU13 interface modul	6DD1 681-0GK0
with screw-plug-in terminal	
SC62 interface cable	6DD1 684-0GC0
between rack SM500 or EXM 438-1 and max. 5 SB10, SB60, SB70, SB 61, SB71 and/or SU12 interface modules, 2 m long	
SC63 interface cable	6DD1 684-0GD0
between rack SM500 or EXM 438-1 and SU13 interface module, 2 m long	

SIMATIC Control Systems

SIMATIC TDC multiprocessor control system

GlobalDataMemory

Overview



GlobalDataMemory

Data can be exchanged between all of the CPU modules in the system, over all of the networked subracks, using the memory in the GlobalDataMemory (GDM). Up to 44 subracks can be coupled in synchronism through the central memory. This means that a maximum of 836 CPU modules can be used.

Technical specifications

CP52M0	
Power supply	
Voltage/current supply (at 25 °C)	+5 V typ. 0.4 A +3.3 V typ. 0.7 A +12 V typ. 0.01 A -12 V typ. 0.01 A
Power loss, typical	4.5 W
Space requirement / width	1 slot
Weight	0.6 kg
Digital outputs	
Number	16
Electrical isolation	No
External power supply voltage	
• Rated value	24 V
• Permissible range	20 to 30
• Briefly	35 V, for max. 0.5 s
• Max. current drain (without load)	40 mA
Output voltage range	
• For a 0-signal, max.	3 V
• For a 1-signal min	External power supply -2.5 V

CP52M0	
Output current	
• For a 0-signal, min.	-20 µA
• For a 1-signal	
- Nominal value	50 mA
- Permissible range, max.	100 mA
Delay time	100 µs
Max. switching frequency of the outputs for an ohmic load	6 kHz
Short-circuit protection with respect to	
• Ground	Yes
• Ext. power supply	No
Max. short-circuit current	250 mA
Summed current of the outputs (up to 60 °C)	16 x 50 mA
Limiting, of inductive switch-off voltages	External power supply voltage + 1 V

CP52IO	
Power supply	
Voltage/current supply (at 25 °C)	+5 V typ. 3 A +3.3 V typ. 0.8 A
Power loss, typical	18 W
Space requirement / width	1 slot
Weight	0.6 kg

CP52A0	
Power supply	
Voltage/current supply (at 25 °C)	+5 V typ. 1.5 A +3.3 V typ. 0.4 A
Power loss, typical	9 W
Space requirement / width	1 slot
Weight	0.6 kg

Ordering data	Order No.
CP52M0 memory module with 2 MB SRAM storage	6DD1 660-0BF0
CP52IO interface module with 4 interfaces	6DD1 660-0BG0
CP52A0 access module for GlobalDataMemory	6DD1 660-0BH0

Overview SB60 interface module



Interface module for connecting 8 digital inputs with 120 V DC/AC to 24 V DC conversion.

Overview SC66 interface cable



Interface cable for the SIMATIC TDC CPU551 processor module and the SB10, SB60, SB61 and SU12 interface modules

Overview SB70 interface module



The interface module is used to connect 8 digital outputs with conversion of the 24 V DC voltage on the module side to a max. of 120 V DC/AC on the plant side using relays.

Overview SC67 service cable



Service cable for the SIMATIC TDC CPU551 module and a local configuration / service PC.

SIMATIC Control Systems

SIMATIC TDC multiprocessor control system

Accessories for SIMATIC TDC

Technical specifications

SB60 interface module	
Number of digital inputs for	8
• Input voltage	120 V DC/AC
Insulating voltage	<ul style="list-style-type: none"> • Safe isolation assured between inputs and outputs • Galvanic isolation assured between input circuits • 1125 V AC test voltage
Connectable conductor cross-section	1.5 mm ²
Dimensions (W x H x D) in mm	45 x 130 x 156
Weight	0.31 kg
SB70 interface module	
Number of digital outputs	8
• Output voltage, max.	120 V DC/AC
Relay switching current	
• at 120 V AC	2 A
• at 120 V DC	0.2 A
Galvanic isolation	via relay
Insulating voltage	<ul style="list-style-type: none"> • Safe isolation assured between inputs and outputs • Galvanic isolation assured between input circuits • 1125 V AC test voltage
Connectable conductor cross-section	1.5 mm ²
Dimensions (W x H x D) in mm	45 x 130 x 156
Weight	0.32 kg

Ordering data

Order No.

SB60 interface module	6DD1 681-0AF4
8 digital inputs, 120 V AC	
SB70 interface module	6DD1 681-0AG2
8 digital outputs with relays	
SC66 interface cable	6DD1 684-0GG0
between CPU551 and interface module SB10, SB60, SB61 or SU12, 2 m long	
SC67 service cable	6DD1 684-0GH0
between CPU551 and PG/PC, 7 m long	

Note:

For more information about SC62, SC63, SC64 interface cables and SB10, SB61, SB71, SU12 and SU13 interface modules see chapter 6, page 6/98.

Software for SIMATIC controllers



11/2	Introduction	11/50	Software for joint tasks in the documentation sector
11/2	Software for SIMATIC Controller	11/50	Technical product data for CAx applications
11/3	Information on software licensing	11/51	Software for joint tasks in the maintenance sector
11/3	Software Update Service	11/51	SIMATIC Maintenance Station
11/4	Controller Software inside TIA Portal	11/53	SIMATIC PDM
11/4	STEP 7 (TIA Portal)	11/57	Software for joint tasks in the administration sector
11/7	STEP 7 Safety (TIA Portal)	11/57	Version cross manager
11/8	STEP 7 programming software	11/58	Version Trail
11/8	STEP 7	11/59	ADDM - Data Management
11/10	STEP 7 Professional	11/60	Additional software
11/13	STEP 7 Micro/WIN	11/60	KNX/EIB2S7
11/14	S7-SCL		
11/16	S7-GRAPH		
11/18	S7-PLCSIM		
11/19	Options for programming and design		
11/19	CFC		
11/21	S7 Distributed Safety		
11/22	S7 F/FH Systems Introduction		
11/23	S7 F/FH Systems S7 F Systems		
11/24	S7 F/FH Systems SIMATIC Safety Matrix		
11/25	Software redundancy		
11/26	SIMATIC iMap		
11/28	DOCPRO		
11/29	Options for diagnostics and service		
11/29	S7-PDIAG		
11/30	TeleService		
11/33	PRODAVE		
11/34	Options for engineering and drive technology		
11/34	PID Professional V11		
11/35	Standard PID Control		
11/37	Modular PID Control		
11/40	PID Self-Tuner		
11/41	Fuzzy Control		
11/43	NeuroSystems		
11/45	S7-Technology		
11/46	Easy Motion Control		
11/48	D7-SYS		
11/49	Drive ES engineering software		

Brochures

For brochures serving as selection guides for SIMATIC products refer to:

www.siemens.com/simatic/printmaterial

Software for SIMATIC controllers

Introduction

Software for SIMATIC Controller

Overview



- System of seamlessly interconnected software tools for SIMATIC S7 and SIMATIC WinAC
- With user-friendly functions for all phases of an automation project
- Comprising:
 - Controller software in the TIA Portal
 - STEP 7 programming software
 - Options for programming and design
 - Options for diagnostics and service
 - Options for technology and drive systems

For brochures serving as selection guides for SIMATIC products refer to:

www.siemens.com/simatic/printmaterial

Overview Licensing

Siemens Industry Automation & Drive Technologies offers various types of software license.

For further information, see catalog section 15, page 15/30.

Overview Software Update Service

- Service for automatic dispatch of all new software versions during contract lifetime
- Reduced logistics effort thanks to automatic contract extension
- Reduced costs as updates are provided free of charge

Ordering

- The Software Update Service is ordered in the same way as any other product. The corresponding order number is given in the ordering information of the software product in question.
- You must own the current version of the software.
- One Software Update Service is ordered for each software license installed.
- The Software Update Service runs for 1 year from date of order.
- It is extended automatically by a further year in each case, as long as it is not canceled 3 months before it expires.
- An annual lump sum is invoiced per license.

Application

SIMATIC software is continuously enhanced and improved. The **Software Update Service** is the easiest way to regularly take advantage of these improvements. This service automatically sends new software updates when they are released so you always have the latest version.

The Software Update Service

- Saves time and effort:
Once it is ordered, the Software Update Service is automatically renewed every year.
- Lowers costs:
The service pays for itself after the first update as it costs less than an individually ordered update.
- Makes budgeting easier:
Software expenditures can be accounted for early in the budgeting process and they are easier to write off.

Design**Scope of delivery**

- All software versions released after ordering the Software Update Service (usually several consignments per year)
- SIMATIC Customer Support Knowledge Base CD-ROM with FAQs, tips & tricks and downloads (several issues per year)

Software for SIMATIC controllers

Controller Software inside TIA Portal

STEP 7 (TIA Portal)

Overview

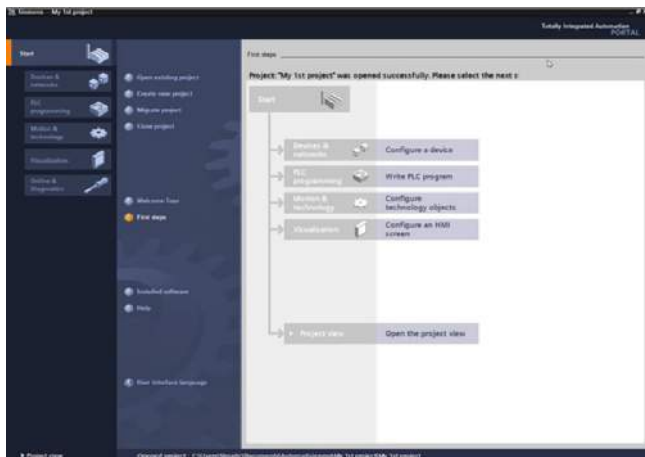

STEP 7 V12 (TIA Portal), portal view

Intuitive, efficient and future-oriented - the engineering software for programming the SIMATIC controllers

SIMATIC STEP 7 Professional V12 is the engineering system for the SIMATIC controllers S7-1200, S7-300, S7-400, WinAC, and also optimally supports the new SIMATIC S7-1500 controllers.

SIMATIC STEP 7 Basic V12 is the engineering system for the S7-1200.

STEP 7 V12 is based on the central engineering framework Totally Integrated Automation Portal (TIA Portal), which offers the user a uniform, efficient and intuitive solution to all automation tasks.

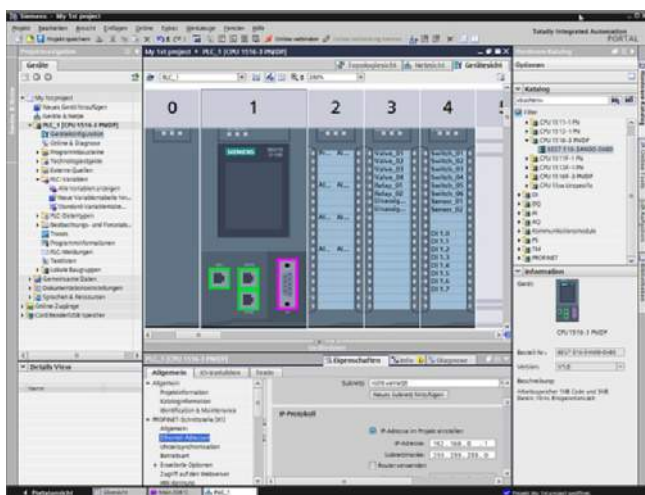

STEP 7 V12 (TIA Portal), device view: configuring and parameterizing in photographically realistic representation

Technical specifications

STEP 7 Professional / Basic V12 (TIA Portal)			
Type of license	Floating license		
Software class	A		
Current version	V12		
Target system	SIMATIC S7-1200, S7-1500, S7-300, S7-400, WinAC		
Operating system	Microsoft Windows XP Home SP3 (STEP 7 Basic only) Windows XP Professional SP3 (32 bit) Microsoft Windows 7 Home Premium SP1 (STEP 7 Basic only) Microsoft Windows 7 Professional SP1 (32/64 bit) Microsoft Windows 7 Enterprise SP1 (32/64 bit) Microsoft Windows 7 Ultimate SP1 (32/64 bit) Microsoft Server 2003 R2 Std. SP2 (32 bit) Microsoft Server 2008 Std. SP2 (32/64 bit)		
Recommended PG/PC hardware with 32 bit operating system	Processor: Core i5, 2.4 GHz or comparable	RAM: 3 GB	Graphics: 1280x1024
Recommended PG/PC hardware with 64 bit operating system	Processor: Core i5, 2.4 GHz or comparable	RAM: 8 GB	Graphics: 1280x1024
Note	Includes the IEC programming languages SCL, LAD, FBD, STL		

Compatibility with other SIMATIC products

STEP 7 Professional / Basic V12 (incl. WinCC Basic V12) can be installed on a PC in parallel with other versions of STEP 7 V11, V5.4 or V5.5, STEP 7 Micro/WIN, WinCC flexible (from 2008) and WinCC (V7.0 SP2 or higher).

Ordering data	Order No.	Order No.
STEP 7 Professional / Basic V12 Target system: SIMATIC S7-1200, S7-1500, S7-300, S7-400, WinAC Requirement: Windows XP Home SP3 (only STEP 7 Basic), Windows XP Professional SP3 (32 bit), Windows 7 Home Premium SP1 (only STEP 7 Basic), Windows 7 Professional SP1 (32/64 bit), Windows 7 Enterprise SP1 (32/64 bit), Windows 7 Ultimate SP1 (32/64 bit), Microsoft Server 2003 R2 Std. SP2 (32 bit), Microsoft Server 2008 Std. SP2 (32/64 bit) Delivery package: German, English, Chinese, Italian, French, Spanish		STEP 7 Professional V12, Trial License 6ES7 822-1AA02-0YA7
		STEP 7 Professional V12 promotional package Only valid if ordered together with a Software Update Service 6ES7 810-5CC04-0YE2 (STEP 7 Professional and STEP 7 Professional in TIA Portal). <ul style="list-style-type: none"> PowerPack & upgrade from STEP 7 V5.5 to STEP 7 Professional 2012/V12, Floating License. Prerequisite is an existing STEP 7 Software Update Service. PowerPack & upgrade from STEP 7 V5.4/V5.5, ... to STEP 7 Professional 2012/V12, Floating License. Prerequisite is an existing STEP 7 Standard/Professional installation.
STEP 7 Professional V12, Floating License	6ES7 822-1AA02-0YA5	6ES7 822-1AA02-0XC2
STEP 7 Professional V12, Floating License, software download incl. license key ¹⁾ E-mail address required for delivery	6ES7 822-1AE02-0YA5	6ES7 822-1AA02-0XC3
		Upgrade STEP 7 Professional V11 to STEP 7 Professional V12, Floating License 6ES7 822-1AA02-0YE5
		Upgrade from STEP 7 Prof. V11 to STEP 7 Professional V12, Floating License, software download incl. license key ¹⁾ E-mail address required for delivery
		6ES7 822-1AE02-0YE5

¹⁾ For up-to-date information and download availability, see: <http://www.siemens.com/tia-online-software-delivery>

Software for SIMATIC controllers

Controller Software inside TIA Portal

STEP 7 (TIA Portal)

Ordering data	Order No.	Order No.
Upgrade from STEP 7 Prof. 2006/2010 to STEP 7 Professional V12, Floating License	6ES7 822-1AA02-0XE5	
Upgrade from STEP 7 Prof. 2006/2010 to STEP 7 Professional V12, Floating License, software download incl. license key¹⁾ E-mail address required for delivery	6ES7 822-1AE02-0XE5	
PowerPack & upgrade from STEP 7 V5.4/V5.5 to STEP 7 Professional V12, Floating License	6ES7 822-1AA02-0XC5	
PowerPack & upgrade from STEP 7 V5.4/V5.5 to STEP 7 Professional V12, Floating License, software download incl. license key¹⁾ E-mail address required for delivery	6ES7 822-1AE02-0XC5	
Powerpack STEP 7 Basic V12 to STEP 7 Professional V12, Floating License	6ES7 822-1AA02-0YC5	
Powerpack STEP 7 Basic V12 to STEP 7 Professional V12, Floating License, software download incl. license key¹⁾ E-mail address required for delivery	6ES7 822-1AE02-0YC5	
STEP 7 Basic V12, Floating License	6ES7 822-0AA02-0YA5	
STEP 7 Basic V12, Floating License, software download incl. license key¹⁾ E-mail address required for delivery	6ES7 822-0AE02-0YA5	
STEP 7 Basic V12, Trial License	6ES7 822-0AA02-0YA7	
Upgrade from STEP 7 Basic V11 to STEP 7 Basic V12, Floating License	6ES7 822-0AA02-0YE5	
Upgrade from STEP 7 Basic V11 to STEP 7 Basic V12, Floating License, software download incl. license key¹⁾ E-mail address required for delivery	6ES7 822-0AE02-0YE5	
Upgrade STEP 7 Basic V10.5 to STEP 7 Basic V11, floating license	6ES7 822-0AA01-0YE0	
Upgrade from STEP 7 Basic V10.5 to STEP 7 Basic V11, Floating License, license key download without software or documentation²⁾ E-mail address required for delivery	6ES7 822-0AA01-0YK5	
		Software Update Service
		For a period of 12 months and for a fixed price, the customer is automatically provided with all upgrades and service packs for each installed software package. The contract is automatically extended by a further year unless canceled at least 12 weeks prior to expiration. Requires the current software version
		Software Update Service (Standard Edition)²⁾
		The delivery is implemented according to the number of ordered SUS products (e.g. 10 upgrade packages with 10 DVDs, 10 USB flash drives, etc.)
		<ul style="list-style-type: none"> • STEP 7 Professional V1x • STEP 7 Professional and STEP 7 Professional in the TIA Portal • STEP 7 Basic
		6ES7 822-1AA00-0YL5
		6ES7 810-5CC04-0YE2
		6ES7 822-0AA00-0YL0
		Software Update Service (Compact Edition)²⁾
		The delivery items are combined. For multiple contracts, only 1 package with 1 data medium set, 1 USB flash drive with the corresponding number of licenses and the corresponding number of COLs will be supplied.
		Delivery items to be combined must be ordered as one item.
		<ul style="list-style-type: none"> • STEP 7 Professional V1x • STEP 7 Professional and STEP 7 Professional in the TIA Portal • STEP 7 Basic
		6ES7 822-1AA00-0YM5
		6ES7 810-5CC00-0YM2
		6ES7 822-0AA00-0YM0

¹⁾ For up-to-date information and download availability, see: <http://www.siemens.com/tia-online-software-delivery>

²⁾ For more information on the Software Update Service, see page 11/3.

Software for SIMATIC controllers

Controller Software inside TIA Portal

STEP 7 Safety (TIA Portal)

Overview

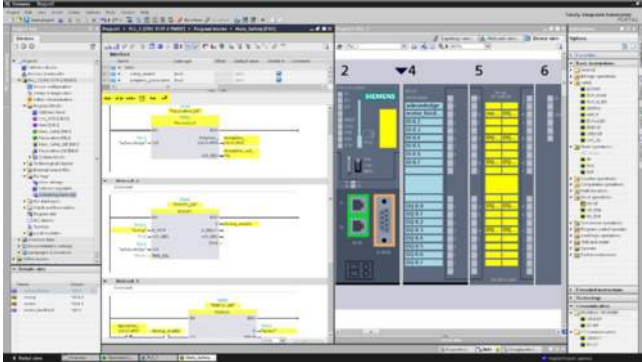

- For creating safety-related programs in the STEP 7 operator interface
- For seamless and easy to use integration of safety-related functions into the standard automation
- All the required configuration and programming tools are integrated into the STEP7 operator interface and utilize a common project structure

Ordering data

Order No.

STEP 7 Safety Advanced V11

Task:

Engineering tool for configuring fail-safe user programs for SIMATIC S7-300F, S7-400F, WinAC RTX F, ET 200S, ET 200M, ET 200iSP, ET 200pro, ET 200eco

Requirement:

STEP 7 Professional V11 SP1

Floating license for 1 user

6ES7 833-1FA11-0YA5

Floating license for 1 user, license key download without software and documentation²⁾;

6ES7 833-1FA11-0YH5

email address required for delivery

Software Update Service (Standard Edition)¹⁾

6ES7 833-1FC00-0YX2

The delivery is implemented according to the number of ordered SUS products (e.g. 10 upgrade packages with 10 DVDs, 10 USB flash drives, etc.) Requires the current software version.

Software Update Service (Compact Edition)¹⁾

6ES7 833-1FC00-0YM2

The delivery items are combined. For several contracts, only 1 package with 1 data medium set, 1 USB flash drive with the corresponding number of licenses and the corresponding number of COLs will be supplied.

The deliveries that are to be grouped together must be ordered as one item.

Requires the current software version.

Minimum order quantity: 5 units

STEP 7 Safety Advanced Upgrade

Distributed Safety V5.4 SP5 and STEP 7 Safety Advanced V11 for parallel use; incl. software on CD; Combo License for 1 user

6ES7 833-1FA11-0YE5

Distributed Safety V5.4 SP5 and STEP 7 Safety Advanced V11 for parallel use; includes software on CD; combo license for 1 user, license key download without software or documentation²⁾;

6ES7 833-1FA11-0YK5

¹⁾ For more information on the software update service, see page 11/3.

²⁾ For up-to-date information and download availability, see: <http://www.siemens.com/tia-online-software-delivery>

Software for SIMATIC controllers

STEP 7 programming software

STEP 7

Overview

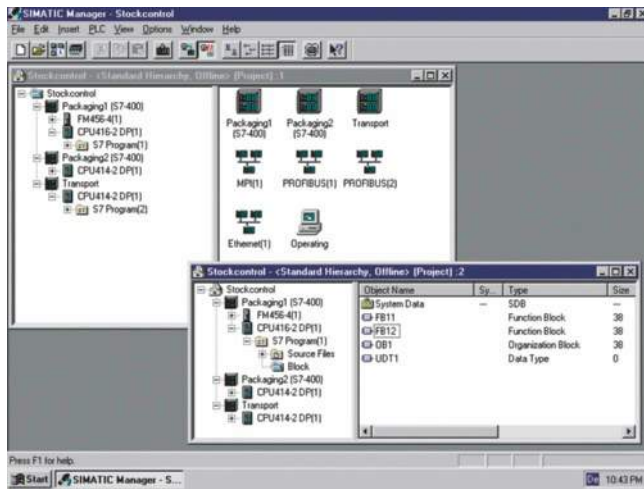

- STEP 7 basic software:
The standard tool for the SIMATIC S7, SIMATIC C7 and SIMATIC WinAC automation systems
- Makes use of the full performance capabilities of the systems
- User-friendly functions for all phases of an automation project:
 - Configuring and parameterizing the hardware
 - Definition of communication
 - Programming
 - Testing, commissioning and service
 - Documentation, archiving
 - Operating, diagnostics functions

Components for connecting a PC to MPI and PROFIBUS

The components described below are used to connect programming devices and PCs (incl. notebooks) to PROFIBUS and to the multipoint SIMATIC S7 MPI interface in conjunction with STEP 7.

PC adapter USB A2

- USB adapter to connect PCs/notebooks and SIMATIC PG/PC to the SIMATIC S7 automation system via the USB port
- For connection to USB 1.1, 2.0 and 3.0 interfaces
- Power supply via the USB port
- PROFIBUS connection with up to 12 Mbit/s
- Supports routing
- Automatic transmission rate and profile search
- Can be used under Windows XP SP2 or higher / Windows 7 or higher, including 64-bit systems
- Scope of delivery:
 - PC adapter USB A2.
 - CD with drivers for the PC adapter USB A2
 - USB cable
 - MPI cable, 0.3 m

CP5512

- For programming devices/ PCs/notebooks with PCMCIA slot
- PCMCIA slot Type II (32 bit cardbus)
- Incl. adapter with 9-pin sub-D socket for connection to PROFIBUS.

CP 5612/CP 5612-MPI

- For programming devices/PCs with PCI slot
- Short PCI card (32 bit)
- CP 5612-MPI including MPI cable

Components for connecting the PC to Industrial Ethernet

The PC modules described below are used to connect programming devices and AT-compatible PCs/notebooks to Industrial Ethernet in conjunction with STEP 7 and SOFTNET-PG (as of V6.0).

CP 1512

- For programming devices/ PCs/notebooks with PCMCIA slot
- PCMCIA slot Type II (32 bit cardbus); 10/100 Mbit/s
- Incl. adapter with RJ45 socket for connection to Industrial Ethernet

CP 1612

- For programming devices/PCs with PCI slot
- Short PCI card (32 bit); 10/100 Mbit/s
- Incl. RJ45 socket for connection to Industrial Ethernet

Please refer to the respective product catalog for technical information regarding product versions and supported operating systems.

You will find additional information about the online connection of PCs and SIMATIC S7/C7 controllers under "SIMATIC NET Communication Systems".

Technical specifications

Standard Tool	STEP 7
Type of license	Floating license
Software class	A
Current version	V 5.5
Target system	SIMATIC S7-300 SIMATIC S7-400
Operating system	Windows XP Professional, Windows 7 Professional, Windows 7 Ultimate
Main memory expansion in PG / PC, min.	Depends on Microsoft Windows operating system used. Recommendation: 1 to 2 GB
Hard drive requirement in PG / PC	Depending on scope of installation, 650 to 900 MB
Size of user program in the CPU	approx. factor 1.5 compared with STEP 5 with AWL (STL - instruction list), KOP (LAD - ladder diagram), FUP (FBD - function block diagram)
Comment	-

Ordering data	Order No.	Order No.
STEP 7 Version 5.5 Target system: SIMATIC S7-300/400, SIMATIC C7, SIMATIC WinAC Requirements: Windows XP Prof., Windows 7 Professional / Ultimate Delivery package: German, English, French, Spanish, Italian; incl. license key on USB stick, with electronic documentation Floating license on DVD Floating License, license key down- load without software and documentation ¹⁾ ; email address required for delivery Rental license for 50 hours Rental License for 50 hours, license key download without software and documentation ¹⁾ ; email address required for delivery Upgrade Floating License 3.x/4.x/5.x to V5.5; on DVD Trial License STEP 7 V5.5; on DVD, 14 day trial	6ES7 810-4CC10-0YA5 6ES7 810-4CE10-0YB5 6ES7 810-4CC10-0YA6 6ES7 810-4CE10-0YB6 6ES7 810-4CC10-0YE5 6ES7 810-4CC10-0YA7	STEP 7 reference manuals Consisting of STL, LAD and FBD manuals as well as a reference manual for standard and system functions for SIMATIC S7-300/400 German English French Spanish Italian SIMATIC Manual Collection Electronic manuals on DVD, multilingual: LOGO!, SIMADYN, SIMATIC bus components, SIMATIC C7, SIMATIC distributed I/O, SIMATIC HMI, SIMATIC Sensors, SIMATIC NET, SIMATIC PC Based Automation, SIMATIC PCS 7, SIMATIC PG/PC, SIMATIC S7, SIMATIC Software, SIMATIC TDC SIMATIC Manual Collection update service for 1 year Current "Manual Collection" DVD and the three subsequent updates EPROM programming device, USB prommer For programming SIMATIC memory cards and EPROM modules MPI cable For linking SIMATIC S7 and PG through MPI (5 m) Components for connecting a PC to MPI and PROFIBUS <i>For PCs with a free PCI slot:</i> CP 5612 CP 5612 MPI incl. MPI cable (5 m) <i>For PCs with a free PCMCIA slot:</i> CP 5512 For Windows XP Professional <i>For PCs without a free PCI slot:</i> USB A2 PC adapter for connecting a PG/PC or Notebook to PROFIBUS or MPI; USB cable included in scope of delivery Components for connecting the PC to Industrial Ethernet <i>For PCs with a free PCI slot:</i> Layer 2 Ethernet cards <i>For PCs with a free PCMCIA slot:</i> SOFTNET-IE RNA V7.1 (Win XP/Vista/Server2003) SOFTNET-IE RNA V8.1 (Win 7/server2008)
STEP 7 Version 5.5 Japanese Target system: SIMATIC S7-300/400, SIMATIC C7, SIMATIC WinAC Requirements: Windows XP Professional Japanese Delivery package: English, Japanese; incl. license key on USB stick, with electronic docu- mentation Floating License Japanese on DVD Upgrade Floating License Japanese 3.x/4.x/5.x to V5.5; on DVD	6ES7 810-4CC10-0JA5 6ES7 810-4CC10-0JE5	6ES7 792-0AA00-0XA0 6ES7 901-0BF00-0AA0
STEP 7 Version 5.5, Chinese Target system: SIMATIC S7-300/400, SIMATIC C7, SIMATIC WinAC Requirements: Windows XP Professional Chinese Delivery package: English, Chinese; incl. license key on USB stick, with electronic docu- mentation Floating License Chinese on DVD Upgrade Floating License Chinese 3.x/4.x/5.x to V5.5; on DVD	6ES7 810-4CC10-0KA5 6ES7 810-4CC10-0KE5	6GK1 561-2AA00 6GK1 561-2AM00 6GK1 551-2AA00 6GK1 571-0BA00-0AA0
Documentation package STEP 7 basic information Comprising Getting Started, hardware configuration manual, programming manual, migration manual German English French Spanish Italian	6ES7 810-4CA10-8AW0 6ES7 810-4CA10-8BW0 6ES7 810-4CA10-8CW0 6ES7 810-4CA10-8DW0 6ES7 810-4CA10-8EW0	6GK1 704-1PW71-3AA0 6GK1 704-1PW08-1AA0

¹⁾ For up-to-date information and download availability, see:
<http://www.siemens.com/tia-online-software-delivery>

Software for SIMATIC controllers

STEP 7 programming software

STEP 7 Professional

Overview



STEP 7 Professional supports all IEC languages.

In addition to the languages recognized by STEP 7

- LAD
- FBD
- IL

The following are also available:

- "Sequential Function Chart"
- "Structured Text"

An offline simulation of programs created with these languages is included. STEP 7 Professional thus replaces the combination of the individual packages STEP 7, S7-GRAPH, S7-SCL and S7-PLCSIM.

A POWERPACK is offered to customers who use STEP 7 already and wish to change. A valid STEP 7 license is required for purchasing the POWERPACK. A separate update service is available for STEP 7 Professional .

Technical specifications

Standard Tool	STEP 7 Professional
Type of license	Floating license
Software class	A
Current version	Edition 2010
Target system	SIMATIC S7-300 SIMATIC S7-400 SIMATIC C7
Operating system	Windows XP Professional, Windows 7 Professional, Windows 7 Ultimate
Main memory expansion in PG / PC, min.	Depends on Microsoft Windows operating system used. Recommendation: 1 to 2 GB
Hard drive requirement in PG / PC	Depending on scope of installation, 700 to 1000 MB
Size of user program in the CPU	approx. factor 1.5 compared with STEP 5 with AWL (STL - instruction list), KOP (LAD - ladder diagram), FUP (FBD - function block diagram)
Comment	Includes all 5 IEC programming languages KOP (LAD - ladder diagram), FUP (FBD - function block diagram), AWL (STL - instruction list), SCL (structured control language), GRAPH and the PLC simulation software S7-PLCSIM

Software for SIMATIC controllers

STEP 7 programming software

STEP 7 Professional

Ordering data	Order No.	Order No.
STEP 7 Professional 2010/V12 Target system: SIMATIC S7-300/400, SIMATIC C7, SIMATIC WinAC Requirements: Windows XP Prof. (32 bit), Windows 7 Professional / Ultimate (32/64 bit) Delivery package: German, English, French, Spanish, Italian; license key on USB stick, with electronic documentation		
Floating combo license on DVD	6ES7 810-5CC11-0YA5	
Floating License, license key download²⁾ without software and documenta- tion; email address required for delivery	6ES7 810-5CE11-0YB5	
Rental license for 50 hours	6ES7 810-5CC11-0YA6	
Rental License for 50 hours, license key download²⁾ without software and documenta- tion; email address required for delivery	6ES7 810-5CE11-0YB6	
Upgrade of Floating License to 2010 Edition; on DVD	6ES7 810-5CC11-0YE5	
Powerpack Floating License for upgrading from STEP 7 to STEP 7 Professional	6ES7 810-5CC11-0YC5	
Trial License STEP 7 Professional 2010; on DVD, runs for 14 days	6ES7 810-5CC11-0YA7	
Software Update Service For a period of 12 months and for a fixed price, the customer is automat- ically provided with all upgrades and service packs for each installed software package. The contract is automatically extended by a further year unless canceled up to 12 weeks prior to expiration. Requires the current software version		
Software Update Service (Standard Edition)¹⁾ The delivery is implemented according to the number of ordered SUS products (e.g. 10 upgrade packages with 10 DVDs, 10 USB flash drives, etc.) • STEP 7 Professional and STEP 7 Professional in the TIA Portal	6ES7 810-5CC04-0YE2	
Software Update Service (Compact Edition)¹⁾ The delivery items are combined. For several contracts, only 1 pack- age with 1 data medium set, 1 USB flash drive with the corresponding number of licenses and the corre- sponding number of COLs will be supplied. The delivery items to be combined must be ordered as one item. • STEP 7 Professional and STEP 7 Professional in the TIA Portal	6ES7 810-5CC00-0YM2	
		Documentation package STEP 7 basic information Comprising Getting Started, hardware configuration manual, programming manual, migration manual German 6ES7 810-4CA10-8AW0 English 6ES7 810-4CA10-8BW0 French 6ES7 810-4CA10-8CW0 Spanish 6ES7 810-4CA10-8DW0 Italian 6ES7 810-4CA10-8EW0
		STEP 7 reference manuals Consisting of STL, LAD and FBD manuals as well as a reference manual for standard and system functions for SIMATIC S7-300/400 German 6ES7 810-4CA10-8AW1 English 6ES7 810-4CA10-8BW1 French 6ES7 810-4CA10-8CW1 Spanish 6ES7 810-4CA10-8DW1 Italian 6ES7 810-4CA10-8EW1
		SIMATIC Manual Collection Electronic manuals on DVD, multilingual: LOGO!, SIMADYN, SIMATIC bus components, SIMATIC C7, SIMATIC distributed I/O, SIMATIC HMI, SIMATIC Sensors, SIMATIC NET, SIMATIC PC Based Automation, SIMATIC PCS 7, SIMATIC PG/PC, SIMATIC S7, SIMATIC Software, SIMATIC TDC 6ES7 998-8XC01-8YE0
		SIMATIC Manual Collection update service for 1 year Current "Manual Collection" DVD and the three subsequent updates 6ES7 998-8XC01-8YE2
		EPROM programming device, USB prommer For programming SIMATIC memory cards and EPROM modules 6ES7 792-0AA00-0XA0
		MPI cable For linking SIMATIC S7 and PG through MPI (5 m) 6ES7 901-0BF00-0AA0

¹⁾ For more information on the software update service, see page 11/3.

²⁾ For up-to-date information and download availability, see:
<http://www.siemens.com/tia-online-software-delivery>

Software for SIMATIC controllers

STEP 7 programming software

STEP 7 Professional

Ordering data	Order No.		Order No.
Components for connecting a PC to MPI and PROFIBUS <i>For PCs with a free PCI slot:</i> CP 5612 CP 5612 MPI incl. MPI cable (5 m)	6GK1 561-2AA00 6GK1 561-2AM00	Components for connecting the PC to Industrial Ethernet <i>For PCs with a free PCI slot:</i> Layer 2 Ethernet cards	
<i>For PCs with a free PCMCIA slot:</i> CP 5512 For Windows XP Professional	6GK1 551-2AA00	<i>For PCs with a free PCMCIA slot:</i> SOFTNET-IE RNA V7.1 (Win XP/Vista/Server2003)	6GK1 704-1PW71-3AA0
<i>For PCs without a free PCI slot:</i> USB A2 PC adapter for connecting a PG/PC or Notebook to PROFIBUS or MPI; USB cable included in scope of delivery	6GK1 571-0BA00-0AA0	SOFTNET-IE RNA V8.1 (Win 7/server2008)	6GK1 704-1PW08-1AA0

Software for SIMATIC controllers

STEP 7 programming software

STEP 7 Micro/WIN

Overview

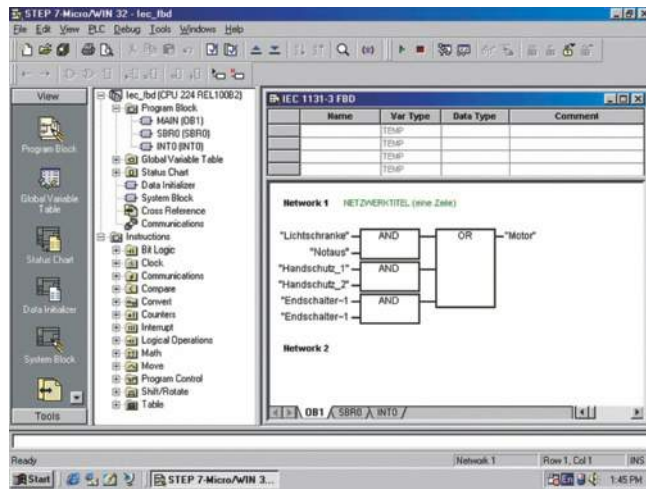

- The simple, easy to learn programming software under Windows 2000/XP for the SIMATIC S7-200
- A large number of wizards support the programming even of difficult automation tasks
- For fast startup and timesaving programming
- With large scope of functions
- Based on standard Windows software (user interface similar to standard applications, such as Microsoft Word, Outlook)
- With 3 standard editors STL, LAD and CSF; you can switch between these editors at any time
- Generation, exporting and importing of user-specific libraries (including standard commands and user-defined subroutines)
- Documentation CD with manuals, software tools and example programs as support

Technical specifications

Standard tool	STEP 7 Micro/WIN
Type of license	Single license
Software class	A
Current version	V 4.0
Target system	SIMATIC S7-200
Operating system	Windows XP SP3 (32-bit) Windows 7 (32/64-bit)
Main memory expansion in programming device / PC, min.	32 MB
Hard drive requirement in programming device / PC	50 MB
Size of user program in the CPU	approx. factor of 1.0 compared with STEP 5 for STL and LAD

Ordering data

Order No.

STEP 7-Micro/WIN V4 programming software

Target system:
All CPUs of the SIMATIC S7-200
Requirement:
Windows XP (32-bit), Windows 7 (32/64-bit); on PG or PC
Delivery package:
German, English, French, Spanish, Italian, Chinese; with online documentation

Single license

6ES7 810-2CC03-0YX0

Single license upgrade¹⁾

6ES7 810-2CC03-0YX3

To be ordered separately:

Intelligent RS 232/PPI multi-master cable

6ES7 901-3CB30-0XA0

For connecting devices with RS 232 interface to SIMATIC S7-200 or PPI network; master in multi-master PPI network

Intelligent USB/PPI multi-master cable

6ES7 901-3DB30-0XA0

for connecting devices with USB interface to SIMATIC S7-200 or PPI network; master in multi-master PPI network

Components for connecting a PC to MPI and PROFIBUS

For PCs with a free PCI slot:

CP 5612

6GK1 561-2AA00

CP 5612 MPI

6GK1 561-2AM00

incl. MPI cable (5 m)

For PCs with a free PCMCIA slot:

CP 5512

6GK1 551-2AA00

for Windows XP Professional

For PCs without a free PCI slot:

PC adapter USB A2

6GK1 571-0BA00-0AA0

for connecting a PG/PC or notebook to PROFIBUS or MPI, USB cable included in scope of supply

¹⁾ Upgrade for all previous STEP 7 Micro/WIN and STEP 7 Micro/DOS versions

Software for SIMATIC controllers

STEP 7 programming software

S7-SCL

Overview

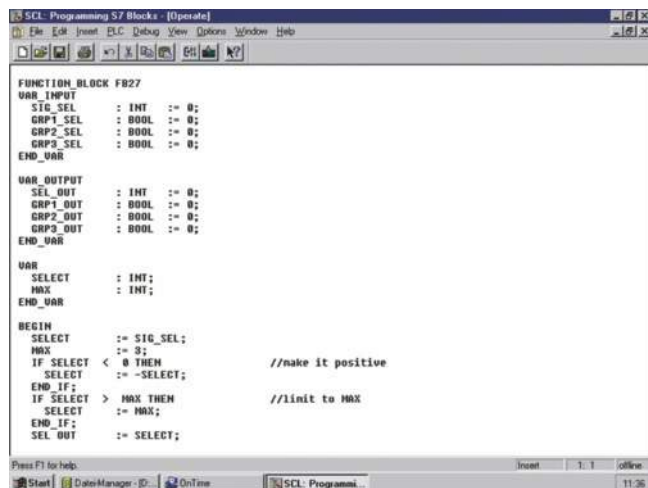

```

FUNCTION_BLOCK FB27
VAR_INPUT
  SIG_SEL      : INT := 0;
  GRP1_SEL    : BOOL := 0;
  GRP2_SEL    : BOOL := 0;
  GRP3_SEL    : BOOL := 0;
END_VAR

VAR_OUTPUT
  SEL_OUT     : INT := 0;
  GRP1_OUT    : BOOL := 0;
  GRP2_OUT    : BOOL := 0;
  GRP3_OUT    : BOOL := 0;
END_VAR

VAR
  SELECT      : INT;
  MAX         : INT;
END_VAR

BEGIN
  SELECT := SIG_SEL;
  MAX := 0;
  IF SELECT < 0 THEN           //make it positive
    SELECT := -SELECT;
  END_IF;
  IF SELECT > MAX THEN       //limit to MAX
    SELECT := MAX;
  END_IF;
  SEL_OUT := SELECT;

```

- PASCAL-type high-level language
- Optimized for programming programmable controllers
- With PLCopen Base Level certificate
- For use in SIMATIC S7-300 (recommended for CPU 314 and CPU 312C or higher), S7-400, C7 and WinAC



Technical specifications

Engineering Tool	S7-SCL
Current version	V5.3
Software class	A
Application areas	
Can be used for	Text-based high-level language programming of simple and complex calculations, CASE, loop, jump, and comparison functions
Marketing message	Programming of algorithms and calculations made easy!
Advantages	<ul style="list-style-type: none"> • Clear and easy-to-read programs • Functional, module-based programming • CASE instruction replaces a large number of jump and comparison functions • Easily understood by PLC programmers, as the programming philosophy of LAD/FBD/STL is retained • Easy switchover to PLC programming for PC programmers • Exchangeability (porting) of subroutines in accordance with IEC 61131-3 • Less time required for engineering compared to LAD/FBD/STL: Up to 20% for simple programs; at least 50% for demanding program structures
Sectors	<ul style="list-style-type: none"> • Labeling machines • Chemical plants (e.g. oxygen extraction, evaluation of measured values) • Rubber and plastics machines • Woodworking machines • Storage and logistics systems • Paper and printing machinery • Punching and cutting machines • Water industry • Coilers
Target systems	
Can be used in	S7-300 (CPU 313 or higher and CPU 312C or higher recommended) S7-400 C7 (C7-626 or higher recommended) WinAC
System prerequisites	
Operating system	Windows XP Professional Windows 7 Ultimate/Professional (S7-SCL V5.3 SP5 and higher)
Required hard drive memory in the PG/PC	50 MB
Required software	STEP 7 V5.4 or higher

Software for SIMATIC controllers

STEP 7 programming software

S7-SCL

Technical specifications (continued)		Ordering data	Order No.
Engineering Tool	S7-SCL	SIMATIC S7 SCL, Version 5.3	
Properties		Task: High-level language programming Target system: SIMATIC S7-300 (CPU 314 and higher), SIMATIC S7-400, SIMATIC C7, SIMATIC WinAC Requirement: STEP 7 V5.4 SP5 and higher Type of delivery: on CD; German, English, French, Spanish, Italian; incl. authorization diskette, with electronic documentation	
Monitoring tags	Yes	Floating License	6ES7 811-1CC05-0YA5
Controlling tags	Yes	Software Update Service (requires current software version) ¹⁾	6ES7 811-1CA01-0YX2
Single-step processing	Yes	Upgrade floating to V5.3	6ES7 811-1CC05-0YE5
Integration in CFC	Yes	SIMATIC Manual Collection	6ES7 998-8XC01-8YE0
Program runtimes		Electronic manuals on DVD, multilingual: LOGO!, SIMADYN, SIMATIC bus components, SIMATIC C7, SIMATIC distributed I/O, SIMATIC HMI, SIMATIC Sensors, SIMATIC NET, SIMATIC PC Based Automation, SIMATIC PCS 7, SIMATIC PG/PC, SIMATIC S7, SIMATIC Software, SIMATIC TDC	
with S7-300 (typical)	Similar to LAD/FBD/STL	SIMATIC Manual Collection update service for 1 year	6ES7 998-8XC01-8YE2
with S7-400 (typical)	Similar to LAD/FBD/STL	Current "Manual Collection" DVD and the three subsequent updates	
Diagnostics			
Integration of diagnostic data in ProAgent	-		
Integration of diagnostic data in ProTool/Pro	-		
Integration of diagnostic data in WinCC	-		
Supported standards			
IEC 61131-3	PLCopen certification • Base level ST available • Reusability Level ST available		
Available versions/licenses			
Floating license	CD-ROM with • Tool • Electronic manual • Getting Started guide • Examples License on USB stick Certificate of License Product information		
Upgrade (floating license)	CD-ROM with • Tool • Electronic manual • Getting Started guide • Examples License on USB stick Certificate of License Product information		
Software Update Service (SUS)			
Also a component part of			
STEP 7 Professional	Yes		
S7 Trainer Package	Yes		
PCS 7	Yes		
D7-SYS	-		

¹⁾ For more information on the software update service, see page 11/3.

Software for SIMATIC controllers

STEP 7 programming software

S7-GRAPH

Overview

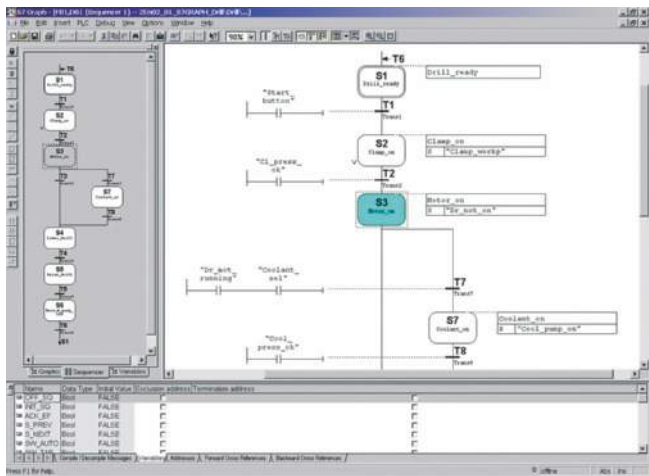

- For configuring and programming sequential processes using sequencers
- Standardized representation to DIN EN 1131-3
- Clearly comprehensible program thanks to structuring of the process into separate steps
- With extensive diagnostics functions, integrated into the SIMATIC diagnostics concept
- With PLCopen Base Level certificate
- For use in SIMATIC S7-300 (recommended for CPU 315 and CPU 312C or higher), S7-400, C7 and WinAC



Technical specifications

Engineering Tool	S7-GRAPH
Current version	V5.3
Software class	A
Application areas	
Can be used for	Graphical programming of sequential controllers and sequencers
Marketing message	Fast, elegant way to program sequential processes easily and transparently!
Advantages	<ul style="list-style-type: none"> • Can be used to optimum effect even during the design phase • Less configuration effort thanks to graphical structuring and programming • Quick and easy familiarization • Precise fault localization thanks to integrated diagnostics in combination with ProAgent for ProTool/Pro and WinCC • Less time required for engineering compared to LAD/FBD/STL: approx. 40 to 70%
Sectors	<ul style="list-style-type: none"> • Automotive industry (e.g. body-in-white, final assembly) • Electrical equipment manufacture • Rubber and plastics machines • Pick-and-place machines • Woodworking machines • Metalworking machines • Paper and printing machinery • Testing machines • Rolling mills • Coilers • Leisure and entertainment facilities
Target systems	
Can be used in	S7-300 (CPU 314 or higher and CPU 312C or higher recommended) S7-400 C7 (C7-626 or higher recommended) WinAC
System prerequisites	
Operating system	Windows XP Professional Windows 7 Professional Windows 7 Ultimate
Required hard drive memory in the PG/PC	50 MB
Required software	STEP 7 V5.4 with SP4 or SP5 or STEP 7 V5.5 with or without SP1

Software for SIMATIC controllers

STEP 7 programming software

S7-GRAPH

Technical specifications (continued)		Ordering data	Order No.
Engineering Tool	S7-GRAPH	SIMATIC S7 GRAPH, Version 5.3	
Properties		Task: Configuration and programming of sequences	
Monitoring tags	Yes	Target system: SIMATIC S7-300, SIMATIC S7-400, SIMATIC C7, SIMATIC WinAC	
Controlling tags	Yes	Requirement: STEP 7 V5.4 or higher with SP4/SP5 or STEP 7 V5.5 with or without SP1	
Single-step processing	Yes	Type of delivery: on CD; German, English, French, Spanish, Italian; including license key on USB stick, with electronic documentation	
Integration in CFC	-	Floating License	6ES7 811-0CC06-0YA5
Program runtimes		Software Update Service (requires current software version) ¹⁾	6ES7 811-0CA01-0YX2
with S7-300 (typical)	3 ms per block + 1 ms per active step	Floating license upgrade to V5.3	6ES7 811-0CC06-0YE5
with S7-400 (typical)	0.4 ms per block + 0.06 ms per active step	SIMATIC Manual Collection	6ES7 998-8XC01-8YE0
Diagnostics		Electronic manuals on DVD, multilingual: LOGO!, SIMADYN, SIMATIC bus components, SIMATIC C7, SIMATIC distributed I/O, SIMATIC HMI, SIMATIC Sensors, SIMATIC NET, SIMATIC PC Based Automation, SIMATIC PCS 7, SIMATIC PG/PC, SIMATIC S7, SIMATIC Software, SIMATIC TDC	
Integration of diagnostic data in ProAgent	Yes	SIMATIC Manual Collection update service for 1 year	6ES7 998-8XC01-8YE2
Integration of diagnostic data in ProTool/Pro	Via ProAgent	Current "Manual Collection" DVD and the three subsequent updates	
Integration of diagnostic data in WinCC	Via ProAgent		
Supported standards			
IEC 61131-3	PLCopen certification • Base Level SFC available		
Status of PLCopen activities	-		
Available versions/licenses			
Floating license	CD-ROM with • Tool • Electronic manual • Getting Started guide • Examples License key on USB stick Certificate of License Product information		
Upgrade (floating license)	CD-ROM with • Tool • Electronic manual • Getting Started guide • Examples License key on USB stick Certificate of License Product information		
Software Update Service (SUS)			
Also a component part of			
STEP 7 Professional	Yes		
S7 Trainer Package	Yes		
PCS 7	-		
D7-SYS	-		

¹⁾ For more information on the software update service, see page 11/3.

Software for SIMATIC controllers

STEP 7 programming software

S7-PLCSIM

Overview

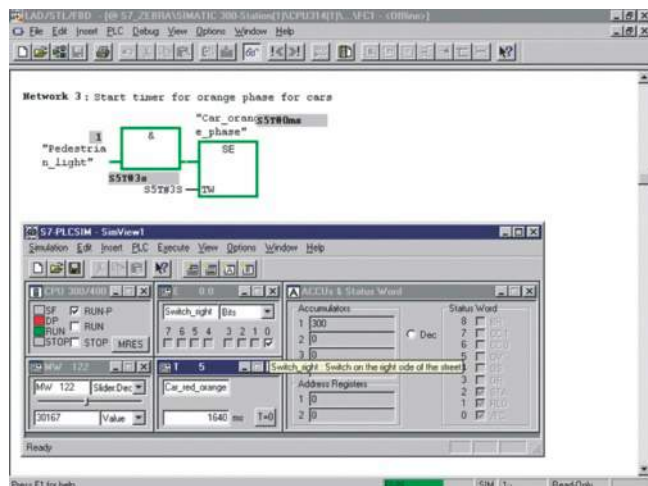

- For functional testing of the generated SIMATIC S7 user blocks on the PG/PC, independent of the availability of the target hardware
- To transfer detection and elimination of program faults to an early phase of program development
- Permits accelerated, cost-reduced initial commissioning, and an increase in program quality
- Can be used for LAD, FBD, STL, S7-GRAPH, S7-HiGraph, S7-SCL, CFC, S7-PDIAG, WinCC (local installation)

Technical specifications

Engineering Tool	S7-PLCSIM
Type of license	Floating license
Software class	A
Current version	V5.4
Target system (recommended)	SIMATIC S7-300 SIMATIC S7-400 SIMATIC C7
Operating system	Windows XP Professional Windows 7 Professional Windows 7 Ultimate
Required software packages	STEP 7 V5.4 with SP4 or SP5 or STEP 7 V5.5 with or without SP1
Disk space required in PG/PC	5 MB

Ordering data

Order No.

S7-PLCSIM, Version 5.4

Task:

Function testing of SIMATIC S7 application blocks on PG/PC

Target system:

SIMATIC S7-300, SIMATIC S7-400, SIMATIC C7

Requirement:

STEP 7 V5.4 or higher incl. SP4/SP5 or STEP 7 V5.5 with or without SP1

Type of delivery:

on CD; English, German, French, Spanish, Italian; license key on USB stick, with electronic documentation

Floating License

6ES7 841-0CC05-0YA5

Software Update Service (requires current software version)¹⁾

6ES7 841-0CA01-0YX2

Floating license upgrade to V5.4

6ES7 841-0CC05-0YE5

SIMATIC Manual Collection

6ES7 998-8XC01-8YE0

Electronic manuals on DVD, multilingual: LOGO!, SIMADYN, SIMATIC bus components, SIMATIC C7, SIMATIC distributed I/O, SIMATIC HMI, SIMATIC Sensors, SIMATIC NET, SIMATIC PC Based Automation, SIMATIC PCS 7, SIMATIC PG/PC, SIMATIC S7, SIMATIC Software, SIMATIC TDC

SIMATIC Manual Collection update service for 1 year

6ES7 998-8XC01-8YE2

Current "Manual Collection" DVD and the three subsequent updates

¹⁾ For more information on the software update service, see page 11/3.

Overview

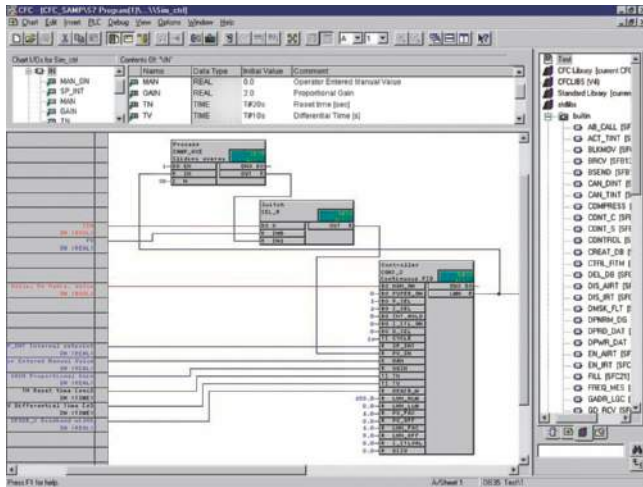

- For creating automation programs by drawing a function chart
- With extensive libraries of prefabricated function blocks to which function blocks created by the user can be added
- Reduced costs and fewer mistakes by simply interconnecting read-to-use function blocks
- Optimized integration in the world of automation, for example, through guaranteed compatibility with all STEP 7 tools
- Can be used for SIMATIC S7-300 (recommended for CPU 316 or CPU 314C or higher), SIMATIC S7-400, SIMATIC WinAC and D7-SYS

Technical specifications

EngineeringTool	CFC
Current version	V8.0
Software class	A
Application areas	
Can be used for	Graphical creation, interconnection and parameterization of (preconfigured) blocks and functions
Marketing message	Simply interconnect and configure instead of programming!
Advantages	<ul style="list-style-type: none"> • Can be used to optimum effect even during the design phase • Reduced configuration effort thanks to graphical interconnection • High degree of reusability of diagrams that have already been created • Quick and easy familiarization • Quick and transparent interconnection of ready-made functions • Technological creation of the program as a whole • Clear representation of control loop structures • Short commissioning time • High plant availability • Less time required for engineering compared to LAD/FBD/STL: up to 50%
Sectors	<ul style="list-style-type: none"> • Automotive industry (e.g. thermostats, tire production processes) • Chemicals • Power engineering and supply • Rubber and plastics machines • Metalworking machines • Food and beverage machines • Petrochemicals • Rolling mills • Water industry • Coilers
Target systems	
Can be used in	S7-300 S7-400 F/H systems WinAC
System prerequisites	
Operating system	MS Windows XP Professional SP3 MS Windows Server 2003 SP2 Standard MS Windows Server 2003 R2 SP2 MS Windows 7 Ultimate 32 Bit MS Windows 7 Ultimate 64 Bit MS Windows Server 2008 32 Bit MS Windows Server 2008 R2 64 Bit MS Windows 7 Professional 32 Bit MS Windows 7 Professional 64 Bit MS Windows Vista 32 Bit Ultimate MS Windows Vista 32 Bit Business
Required hard drive memory in the PG/PC	approx. 80 MB
Required software	STEP 7 V5.4 SP5 or higher

Software for SIMATIC controllers

Options for programming and design

CFC

Technical specifications (continued)

EngineeringTool	CFC
Properties	
Monitoring tags	Yes
Controlling tags	Yes
Single-step processing	-
Integration in CFC	Yes
Program runtimes	
with S7-300 (typical)	Depending on the interconnected blocks
with S7-400 (typical)	Depending on the interconnected blocks
Diagnostics	
Integration of diagnostic data in Pro-Agent	-
Integration of diagnostic data in Pro-Tool/Pro	-
Integration of diagnostic data in WinCC	-
Supported standards	
IEC 61131-3	based on the IEC standard
Status of PLCOpen activities	-
Available versions/licenses	
Floating license (S7-HiGraph) or single license (CFC)	CD-ROM with <ul style="list-style-type: none"> • Tool • Electronic manual • Getting Started guide • Examples License Key Disk Terms and Conditions Certificate of License
Floating license (S7-HiGraph) or single license (CFC)	CD-ROM with <ul style="list-style-type: none"> • Tool • Electronic manual • Getting Started guide • Examples License Key Disk Emergency Key Disk Certificate of License Terms and Conditions Product information
Software Update Service (SUS)	
Also a component part of	
STEP 7 Professional	-
S7 Trainer Package	-
PCS 7	Yes
D7-SYS	Yes

Ordering data

Order No.

SIMATIC CFC, Version 8.0 Task: Graphic configuring and programming of automation applications in the form of technology-oriented diagrams Target system: SIMATIC S7-300/400, SIMATIC WinAC, D7-SYS Requirements: STEP 7 V5.3 and higher Delivery form: Engineering software and electronic documentation on CD-ROM, License Key on USB stick, Certificate of License Floating License Floating License upgrade from V7.1 to V8.0 Software Update Service (requires current software version) ¹⁾ Software Update Service for multiple orders (requires current software version); the delivery items are combined. For several contracts, only 1 package (1 data medium set and the corresponding number of licenses) will be supplied. Can be ordered with 5 or more contracts ¹⁾ The delivery items to be combined must be ordered as one item.	6ES7 658-1EX08-0YA5 6ES7 658-1EX08-0YE5 6ES7 658-1EX00-2YL8 6ES7 658-1EX00-2YM8
SIMATIC Manual Collection Electronic manuals on DVD, multilingual: LOGO!, SIMADYN, SIMATIC bus components, SIMATIC C7, SIMATIC distributed I/O, SIMATIC HMI, SIMATIC Sensors, SIMATIC NET, SIMATIC PC Based Automation, SIMATIC PCS 7, SIMATIC PG/PC, SIMATIC S7, SIMATIC Software, SIMATIC TDC	6ES7 998-8XC01-8YE0
SIMATIC Manual Collection update service for 1 year Current "Manual Collection" DVD and the three subsequent updates	6ES7 998-8XC01-8YE2

¹⁾ For more information on the software update service, see page 11/3.

Software for SIMATIC controllers

Options for programming and design

S7 Distributed Safety

Overview

- For creating safety-oriented automation applications with SIMATIC S7 in LAD or FBD (STEP 7 required)
- Implementation of safety functions by making simple connections between function blocks
- With preconfigured function block library
- User-defined blocks can be created
- Optimum embedding in the automation world due to guaranteed integration with STEP 7 tools
- Scope of supply:
 - Distributed Safety editor
 - Code generator
 - Debugger
 - Libraries of standard blocks

Ordering data

Order No.

S7 Distributed Safety V5.4 programming tool

Task:

Configuration software for configuring fail-safe user programs for SIMATIC S7-300F, S7-400F, WinAC RTX F, ET 200S, ET 200M, ET 200iSP, ET 200pro, ET 200eco

Requirement:

STEP 7 V5.3 SP3 and higher

Floating license for 1 user

6ES7 833-1FC02-0YA5

Floating license for 1 user, license key download without software or documentation¹⁾; email address required for delivery

6ES7 833-1FC02-0YH5

S7 Distributed Safety upgrade

From V5.x to V5.4;

Floating license for 1 user

6ES7 833-1FC02-0YE5

¹⁾ For up-to-date information and download availability, see: <http://www.siemens.com/tia-online-software-delivery>

Software for SIMATIC controllers

Options for programming and design

S7 F/FH Systems Introduction

Overview

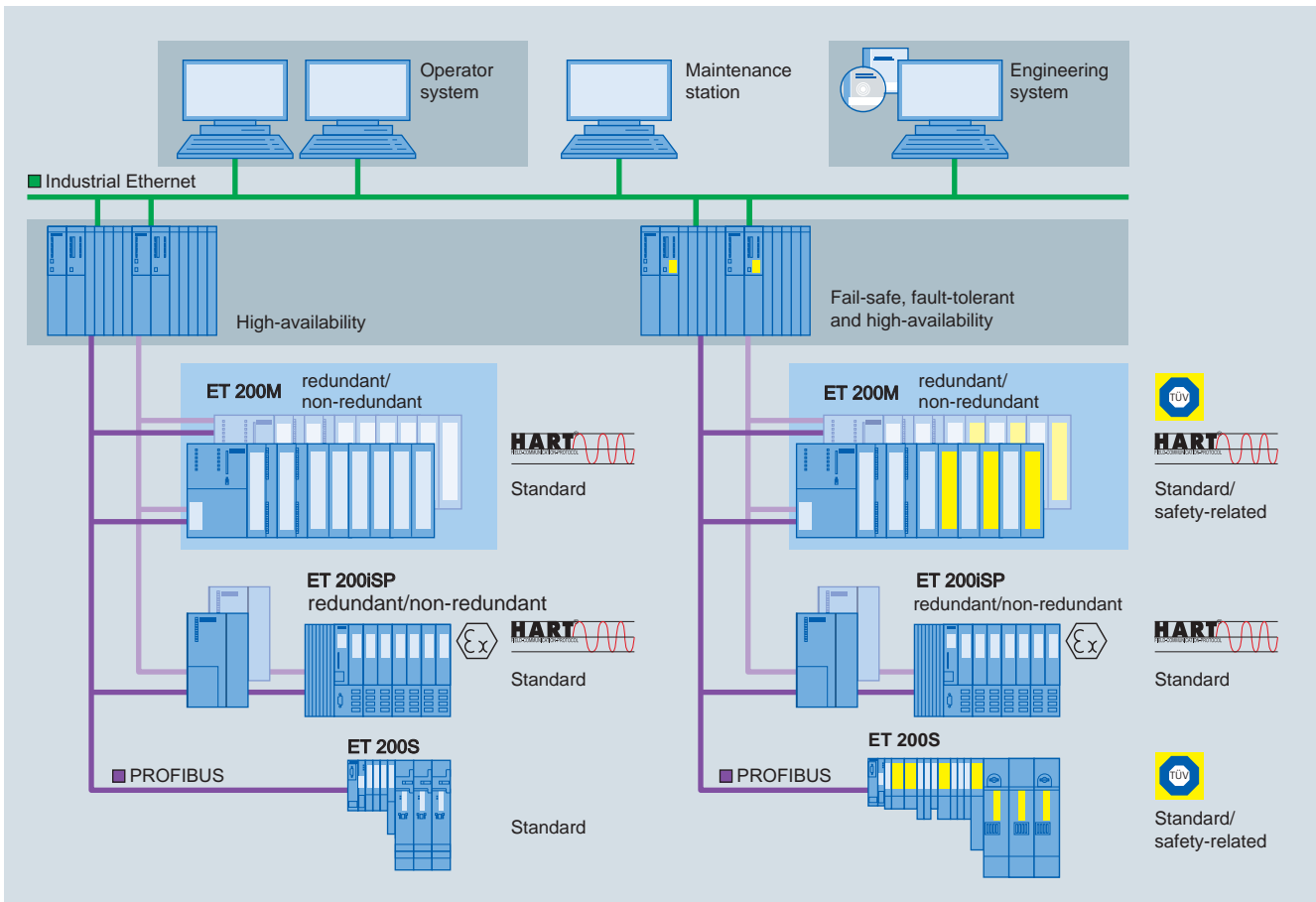

Common engineering system for basic process control system and safety instrumented system

The process industry frequently features complex technological sequences with high safety demands, and faults and failures in the process automation could have fatal consequences for personnel, machines, plants and the environment. Therefore process safety is of particular significance. The safety technology used must reliably detect errors in the process and also its own internal errors, and automatically set the plant/application to a safe state if an error is detected.

S7 F/FH Systems is the comprehensive range of products and services from Siemens for safe, fault-tolerant applications in the process industry. This is characterized by:

- Safe communication via PROFIBUS with PROFIsafe
- Safe communication also via PROFIBUS PA with PROFIsafe
- ET 200 distributed I/O systems with safety-related I/O modules
- User-friendly process visualization, including safety-relevant fault messages, via the optional operator system
- Engineering system with S7 F Systems software package and SIMATIC Safety Matrix

- AS 412F/FH, AS 414F/FH and AS 417F/FH safety-related automation systems
- The safety-related automation systems of the S7 F/FH-System are based on the hardware of the CPU 412H, CPU 414H or CPU 417H automation systems that are extended with the S7 F Systems software package to include safety functions. All F/FH systems listed are TÜV-certified and comply with the safety requirements up to SIL 3 according to IEC 61508. There are two design variants:
- Single-channel (with one CPU, safety-related)
 - High-availability (with redundant CPUs, safety-related and fault-tolerant)

Software for SIMATIC controllers

Options for programming and design

S7 F/FH Systems
S7 F Systems

Overview

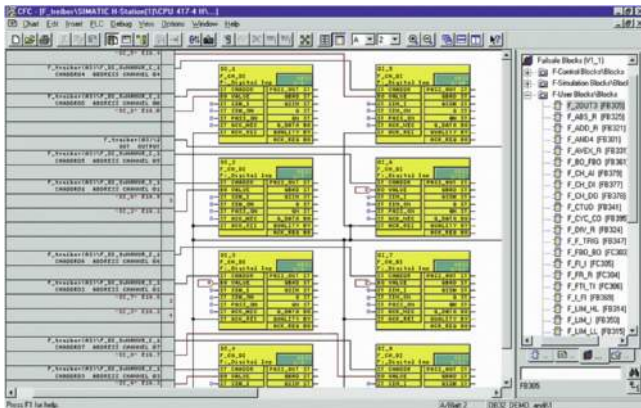

The S7 F Systems engineering tool integrated in the SIMATIC Manager can be used to configure an S7 F/FH System. With this tool you can:

- Parameterize CPU and F-signal modules
- Create safety-related applications in the CFC.

Predefined, TÜV-approved blocks are available for this purpose. The safety-related blocks save the user having to perform redundant programming for detecting and reacting to errors.

Ordering data

Order No.

S7 F Systems RT license

6ES7 833-1CC00-6YX0

For processing safety-related application programs, for one AS 412F/FH, AS 414F/FH or AS 417F/FH

S7 F Systems V6.1

6ES7 833-1CC02-0YA5

Programming and configuring environment for creating and operating safety-related STEP 7 programs for an S7 400H-based target system, floating license for 1 user, executable under Windows XP Prof SP2/SP3, Windows Server 2003 SP2, Windows 7, Windows Server 2008 R2

2 languages (German, English)

Type of supply:

Certificate of license as well as software and electronic documentation on CD

S7 F systems upgrade from V5.x/V6.0 to V6.1

6ES7 833-1CC02-0YE5

2 languages (German, English), floating license for 1 user

Type of supply:

Certificate of license as well as software and electronic documentation on CD

Note:

In the case of an S7 F Systems Upgrade from V5.x to V6.1, the type of S7 F Systems license changes from single license to floating license.

Software for SIMATIC controllers

Options for programming and design

S7 F/H Systems SIMATIC Safety Matrix

Overview

Input Tag	Func	Limit/Trip	Engl./Int	Cause Description	Sum	1	2	3	4	5	6	7	8	9	10	11	12	13	14
PS_100		FALSE		Feed Pump High Pressure Switch	1	N													
LSH_100		TRUE		Tank_100 Level switch high	2	S	S		R										
LSL_200		TRUE		Hopper_200 Level switch Low	3	N	N		2S										
PSH_200		TRUE		Hopper_200 High Pressure	4	N	N		V										
PT_100		H 35.00	PSIG	Feed pressure	5	S	S	S											
LT_100		H 50.00	Feet	Tank Level	6	S	N	N											
PT_101		H 25.00		Tank Pressure	7														
PT_102		D 3.0																	
PT_103	Vote																		
LT_200		H 50.00	ft	Hopper Level	8														
TS_101		FALSE																	
TS_102	AND	FALSE		Tank_100 High Temperature switch	9														
TS_103		FALSE																	

The SIMATIC Safety Matrix which can be used in addition to the CFC is an innovative safety lifecycle tool from Siemens that can be used not only for user-friendly configuration of safety applications, but also for their operation and service. The tool, which is based on the proven principle of a cause & effect matrix, is ideally suited to processes where defined statuses require specific safety reactions.

The SIMATIC Safety Matrix not only means that programming of the safety logic is significantly simpler and more convenient, but also much faster than in the conventional manner. During the risk analysis of a plant, the configuration engineer can assign exactly defined reactions (effects) to events (causes) which may occur during a process.

Ordering data

Order No.

SIMATIC Safety Matrix Tool V6.2

Creation, configuration, compilation, loading and online monitoring of the Safety Matrix in a SIMATIC PCS 7 environment

Including SIMATIC Safety Matrix Viewer for SIMATIC PCS 7, for operation and monitoring of the Safety Matrix in a SIMATIC PCS 7 environment with several operator control levels

1 language (English), executes with Windows XP Professional, Windows 7, Windows Server 2008 R2

Type of supply: Certificate of License and authorization diskette for Safety Matrix Tool and Safety Matrix Viewer; software and electronic documentation on CD

Floating License for 1 installation

6ES7 833-1SM02-0YA5

Floating License upgrade from V5.x/V6.x to V6.2

6ES7 833-1SM02-0YE5

SIMATIC Safety Matrix Editor V6.2

Creation and checking of the Safety Matrix logic on an external computer without a SIMATIC PCS 7 or STEP 7 environment

1 language (English), executes with Windows 2000 Professional or Windows XP Professional, Windows 7, Windows Server 2008 R2, single license for 1 installation

Type of supply: Certificate of License and authorization diskette; software and electronic documentation on CD

6ES7 833-1SM42-0YA5

SIMATIC Safety Matrix Viewer V6.2 for SIMATIC PCS 7

Operation and monitoring of the Safety Matrix in the SIMATIC PCS 7 environment with several operating levels

Bilingual (English/German), runs on Windows 2000 Professional or Windows XP Professional, Windows 2003 Server, Windows 7, Windows Server 2008 R2

Type of supply: Certificate of License and authorization diskette; software and electronic documentation on CD

Floating License for 1 installation

6ES7 833-1SM62-0YA5

Floating License upgrade from V6.x to V6.2

6ES7 833-1SM62-0YE5

Overview

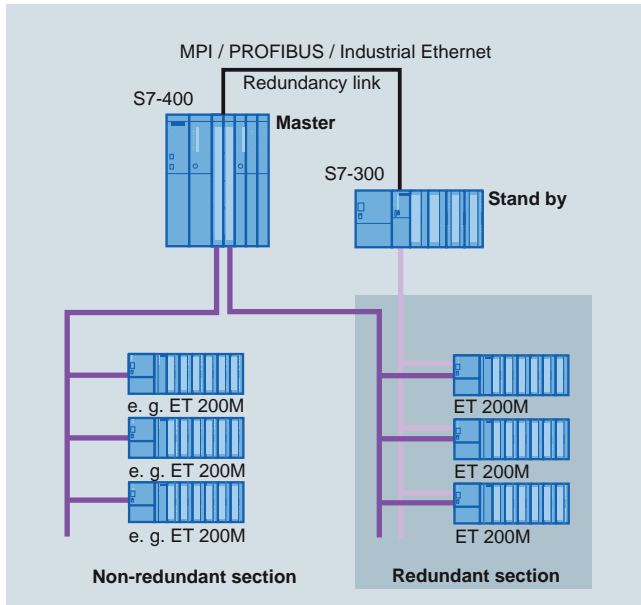

- Software package for assembling fault-tolerant control systems based on software
- Designed for control systems with single-channel distributed I/O
- For use in applications with low demands on changeover speed, such as the control of hydroelectric power plants, cooling circuits, traffic flows, level control, measured data acquisition
- Inexpensive thanks to the use of standard S7-300 and S7-400 components
- I/O linking with PROFIBUS DP in redundant configuration
- Optional control via WinCC operator station

Technical specifications

Hardware requirements	
CPU	S7-300: CPU 313C-2 DP, 314C-2 DP, 315-2 DP, 316-2 DP, 318-2 DP S7-400: all CPUs
Redundancy link of the CPUs	MPI, PROFIBUS, Industrial Ethernet; existing connections can also be used.
Suitable modules for ET 200M	IM 153-2; all DI/O, AI/O for ET 200M; FM 350-1 counter module CP 341
Software requirements	
Configuring/programming	STEP 7 V4.0
Communication configuration for redundant PROFIBUS DP	NCM S7 for PROFIBUS

Ordering data

Order No.

Program package software redundancy V1.2

Task:

Configuring a redundant control.
Target system: SIMATIC S7-300,
S7-400

Requirement:

STEP 7 V5.2, NCM S7 for
PROFIBUS

Delivery package:

incl. electronic documentation
(English, German, French, Spanish,
Italian), 4 application examples and
faceplate for WinCC on CD-ROM

Single license (for 2 CPUs)

6ES7 862-0AC01-0YA0

Single license, without software and
documentation

6ES7 862-0AC01-0YA1

SIMATIC Manual Collection

6ES7 998-8XC01-8YE0

Electronic manuals on DVD,
multilingual: LOGO!, SIMADYN,
SIMATIC bus components,
SIMATIC C7,
SIMATIC distributed I/O,
SIMATIC HMI,
SIMATIC Sensors,
SIMATIC NET,
SIMATIC PC Based Automation,
SIMATIC PCS 7,
SIMATIC PG/PC,
SIMATIC S7,
SIMATIC Software,
SIMATIC TDC

SIMATIC Manual Collection update service for 1 year

6ES7 998-8XC01-8YE2

Current "Manual Collection" DVD
and the three subsequent updates

Software for SIMATIC controllers

Options for programming and design

SIMATIC iMap

Overview

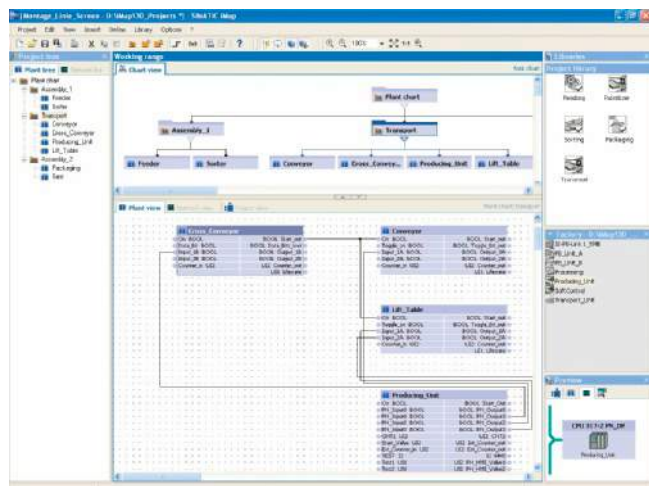

- Component-based software tool for configuring the communication in distributed automation solutions
- For easy graphical configuration of the communication between subsystems and machine-to-machine communication in the production line
- Based on the PROFINET standard
- Open for PROFINET devices from various manufacturers on Industrial Ethernet
- Runs under Windows XP Professional and Windows 7 Ultimate/Professional

Technical specifications

Engineering tool	SIMATIC iMap
Current version	V3.0
Software class	A
Application areas	
Keyword	SIMATIC iMap is an engineering tool for configuring communication between automation and field devices in distributed automation solutions.
Marketing message	"Time and cost savings in modular machine and plant construction with Component based Automation." "Modularization and machine-to-machine communication along the production line."
Advantages	<ul style="list-style-type: none"> • Open component-based engineering tool to the PROFINET standard. • Simple communication between intelligent automation and field devices on PROFIBUS DP and on Ethernet. • Graphical configuration of communication on PROFIBUS DP and on Ethernet • Extremely high reusability of software components (technology modules) • Graphical structuring of the plant using "chart-in-chart" function • Convenient navigation through the project tree • Easy creation and structuring of technology libraries • PROFIBUS and Ethernet in the overview of the network view • Fast start-up thanks to downloading and testing directly on Ethernet (also of PROFIBUS slaves) • Online display of values of the technology modules on the interfaces and in the variable table • Diagnosis of communication in the diagnostics window

Engineering tool	SIMATIC iMap
Sectors	<ul style="list-style-type: none"> • Automotive industry (especially in assembly, conveyor systems and in the paint shop) • Complex food and packaging machines • Conveyor systems based on PROFIBUS DP • Production lines with several interlinked machines
Target systems	<ul style="list-style-type: none"> • SIMATIC S7 CPU 31x-2 PN/DP and SIMATIC S7 CPU 319-3 PN/DP (with integrated PROFINET interface. This can be used as a proxy function for the devices of a complete PROFIBUS segment, one line only) • SIMATIC WinAC PN (can be used as a proxy function for the devices of a complete PROFIBUS segment, one line only) • SIMATIC NET IE/PB Link (can be used as a proxy function for the devices of a complete PROFIBUS segment) • SIMATIC NET CP 343-1 and CP 343-1 Advanced (for connecting SIMATIC S7-300 to Ethernet), CP443-1 Advanced (for connecting SIMATIC S7-400 to Ethernet) • Distributed I/O stations with separate CPU (all intelligent field devices on PROFIBUS such as SIMATIC CPU 313C-2DP, CPU 314C-2DP, CPU 315-2DP, CPU 316-2DP, ET 200 IM 151 CPU, ET 200S BM 147 CPU), • PROFINET CBA OPC Server (for access from PC applications to data in PROFINET devices) • Devices on Industrial Ethernet based on the PROFINET CBA standard • SIMATIC OPs (within the components) • SIMATIC ProTool/Pro, WinCC or any other visualization system with OPC client function

Software for SIMATIC controllers

Options for programming and design

SIMATIC iMap

Technical specifications (continued)		Ordering data	Order No.
Engineering tool	SIMATIC iMap	SIMATIC iMap V3.0	
System prerequisites		Target system: CPU 31x-2 PN/DP, CPU 319-3 PN/DP, SIMATIC WinAC PN, SIMATIC NET IE/PB Link, SIMATIC NET CP 343-1, SIMATIC NET CP 343-1 Advanced, SIMATIC NET CP 443-1 Advanced, distributed I/O devices with own CPU, PROFINET CBA OPC server, devices on the Industrial Ethernet based on the PROFINET CBA stan- dard, SIMATIC OPs, SIMATIC ProTool/Pro	
Operating system	Windows XP Prof. with Service Pack 2 or Windows 7 Ultimate/Professional; PC administration rights are required for installation	Requirements: Windows XP Prof. with Service Pack 2 or Windows 7 Ultimate/Professional; on PG or PC with Pentium processor, min. 1 GHz; STEP 7 V5.3 or higher with Service Pack 3, PN OPC Server V6.3 or higher	
PG/PC hardware	Pentium processor, 1 GHz or higher	Type of delivery: German, English, with electronic documentation	
Recommended expansion of main memory in PG/PC	RAM: 512 MB or more	Floating License	6ES7 820-0CC04-0YA5
Hard disk space required in PG/PC	Approx. 200 MB	Software Update Service (requires current software version) ¹⁾	6ES7 820-0CC01-0YX2
Software required	<ul style="list-style-type: none"> • STEP 7 V5.3 Service Pack 3 or higher • PN OPC-Server V6.3 or higher The following software must be installed before iMap (included in the iMap package): <ul style="list-style-type: none"> • MS Internet Explorer V6.0 Service Pack 1 and higher • Adobe Acrobat Reader V5.0 	Upgrade to V3.0, floating license	6ES7 820-0CC04-0YE5
Delivery format			
Languages	English, German, French, Italian and Spanish		
Single License (SL)	Yes		
Upgrade License (UL)	Yes, from V2.0 to V3.0		
Paper manuals	Electronically on CD		
Authorization/licenses			
Authorization	Yes		
Single License (SL)	Yes		
Upgrade License (UL)	Yes		
Software Update Service	Yes		
Unlock Copy License	No		

¹⁾ For more information on the software update service, see page 11/3.

Software for SIMATIC controllers

Options for programming and design

DOCPRO

Overview

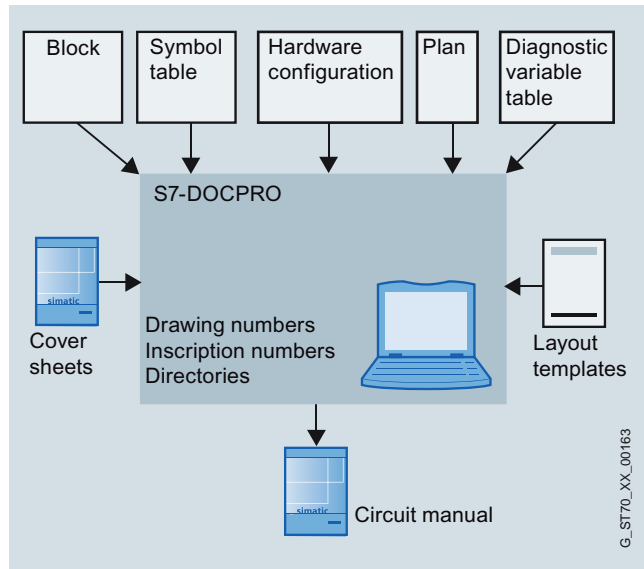

- For creating and managing plant documentation
- Permits structuring of project data, the preparation in the form of wiring manuals, and the printout in a unified print image.
- For use in SIMATIC S7-300, S7-400 and C7

Technical specifications

Engineering Tool	DOCPRO
Type of license	Floating license
Software class	A
Current version	V5.4
Target system (recommended)	SIMATIC S7-300/400 SIMATIC C7
Operating system	Windows XP Professional Windows 7 Ultimate/Professional from DOCPRO V5.4 SP1
Required software packages	STEP 7, V5.4 and higher; for operation under Windows 7 STEP 7, V5.5 and higher
Disk space required in PG/PC	5 MB

Ordering data

Order No.

DOCPRO, Version 5.4

Task:
Creation of circuit manuals for plant documentation management
Target system:
SIMATIC S7-300, SIMATIC S7-400, SIMATIC C7
Requirement:
from STEP 7 V5.4
Delivery package:
on CD; German, English, French, Spanish, Italian; incl. authorization diskette, with electronic documentation

Floating License

6ES7 803-0CC03-0YA5

Software Update Service (requires current software version)¹⁾

6ES7 803-0CA01-0YX2

Floating license upgrade to V5.4

6ES7 803-0CC03-0YE5

SIMATIC Manual Collection

6ES7 998-8XC01-8YE0

Electronic manuals on DVD, multilingual: LOGO!, SIMADYN, SIMATIC bus components, SIMATIC C7, SIMATIC distributed I/O, SIMATIC HMI, SIMATIC Sensors, SIMATIC NET, SIMATIC PC Based Automation, SIMATIC PCS 7, SIMATIC PG/PC, SIMATIC S7, SIMATIC Software, SIMATIC TDC

SIMATIC Manual Collection update service for 1 year

6ES7 998-8XC01-8YE2

Current "Manual Collection" DVD and the three subsequent updates

¹⁾ For more information on the software update service, see page 11/3.

Software for SIMATIC controllers

Options for diagnostics and service

S7-PDIAG

Overview

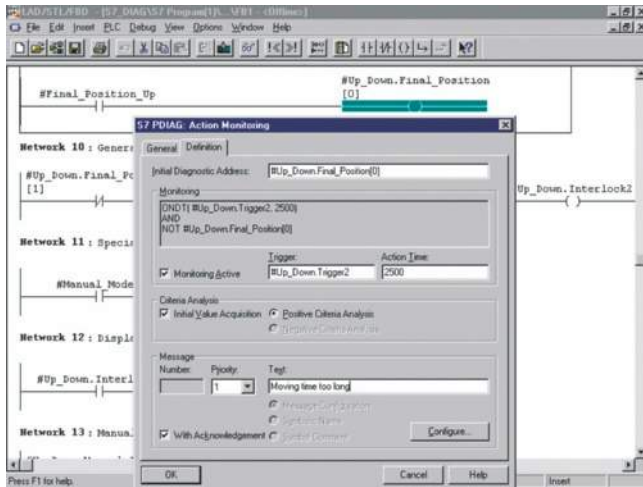

- For configuration of process diagnostics with SIMATIC S7
- Increases the availability of machines and production plants and supports with fault analysis and elimination on site
- For use on the SIMATIC S7-300, S7-400

Technical specifications

Engineering Tool	S7-PDIAG
Type of license	Floating license
Software class	A
Current version	V5.3
Target system (recommended)	SIMATIC S7-300 (CPU 314 or higher) SIMATIC S7-400
Operating system	Windows XP Professional Windows 7 Ultimate/Professional
Required software packages	STEP 7 V5.4 or higher
Disk space required in PG/PC	6 MB

Ordering data

Order No.

S7-PDIAG, Version 5.3

Task:
Configuring of process diagnostics for LAD/FBD/STL

Target system:
SIMATIC S7-300 (CPU 314 and higher); SIMATIC S7-400

Requirement:
STEP 7 V5.4 or higher

Type of delivery:
on CD; German, English, French, Spanish, Italian; incl. authorization diskette, with electronic documentation

Floating License

6ES7 840-0CC04-0YA5

Software Update Service (requires current software version)¹⁾

6ES7 840-0CA01-0YX2

Upgrade to V5.3

6ES7 840-0CC04-0YE5

SIMATIC Manual Collection

6ES7 998-8XC01-8YE0

Electronic manuals on DVD, multilingual: LOGO!, SIMADYN, SIMATIC bus components, SIMATIC C7, SIMATIC distributed I/O, SIMATIC HMI, SIMATIC Sensors, SIMATIC NET, SIMATIC PC Based Automation, SIMATIC PCS 7, SIMATIC PG/PC, SIMATIC S7, SIMATIC Software, SIMATIC TDC

SIMATIC Manual Collection update service for 1 year

6ES7 998-8XC01-8YE2

Current "Manual Collection" DVD and the three subsequent updates

¹⁾ For more information on the software update service, see page 11/3.

Software for SIMATIC controllers

Options for diagnostics and service

TeleService

Overview

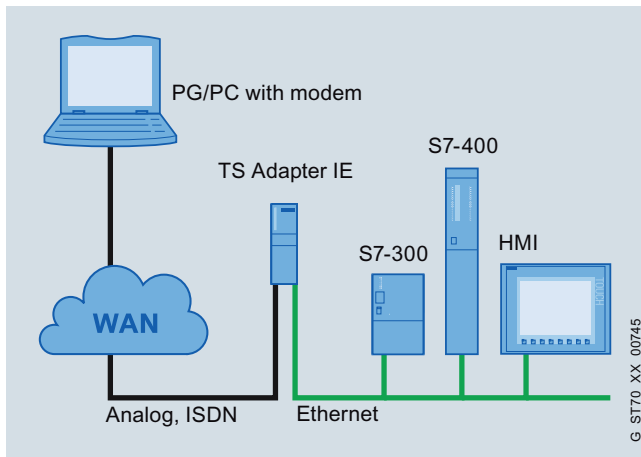

Teleservice with TS Adapter IE

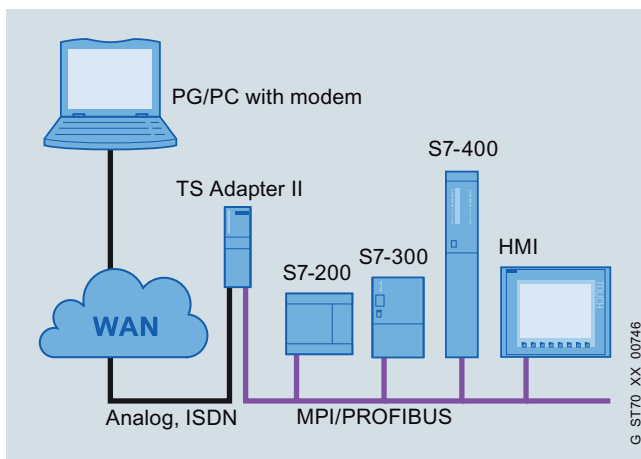

Teleservice with TS Adapter II

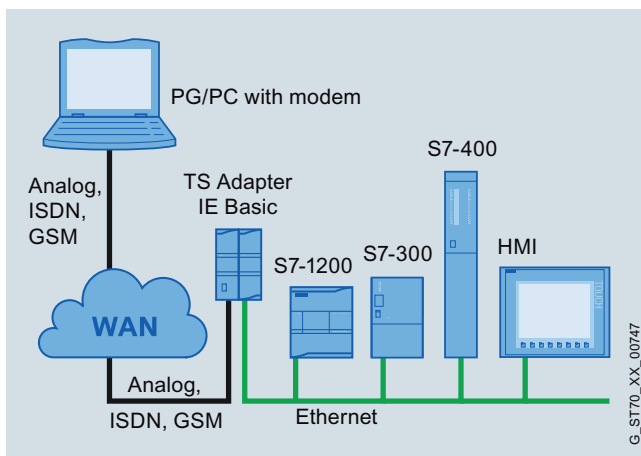

Teleservice with TS Adapter IE Basic

- For performing remote maintenance over the telephone network:
A PG/PC with an Engineering Tool installed, e.g. STEP 7, can access automation components (e.g. S7 CPUs) over the telephone network that are connected to the appropriate adapters over Industrial Ethernet or PROFIBUS.
- Comprising the TeleService software and different adapters:
 - TS Adapter II for connection to PPI, MPI or PROFIBUS DP
 - TS Adapter IE or TS Adapter IE Basic for connection to Industrial Ethernet
- Additional functions with TS Adapter II:
 - Establishing a connection from/to remote plants, e.g. for calling up process data from an automation system (*PG-to-AS remote coupling*).
 - Exchanging data between plants (*AS-to-AS remote coupling*):
Exchange of process data between two SIMATIC automation systems.
 - Sending a *text message*:
Sending a text message from a SIMATIC automation system via a GSM wireless modem.
- Additional functions with TS Adapter IE:
 - Remote operation of HMI devices:
Access to the HMI device via an Internet browser installed on the adapter
 - Sending e-mails:
Establishing a modem link to a dial-up server (e.g. to an Internet service provider): A SIMATIC CPU can send e-mails over an e-mail server that can be accessed in this manner.
 - Standard routing:
A modem link can be established to an Internet service provider for accessing data on the Internet.

Technical specifications

TS Adapter II	
Dimensions (W x H x D) in mm	125 x 110 x 40
Weight, approx.	250 g
Interfaces	<ul style="list-style-type: none"> to S7/C7 to the PC to an external modem to the analog telephone network to the ISDN telephone network
	RS 485 (up to 12 Mbit/s) USB 1.1 (12 Mbit/s) RS 232 (up to 115 kbaud) RJ12 RJ45
Supply voltage, external or via MPI interface	24 V DC
Current consumption	60 mA (typ.) / 120 mA (max.)
Switch-on current, max.	0.7 A; 8 µs
Degree of protection	IP20
Temperature	
• Operation	± 0 °C to +60 °C
• Storage/transport	-40 °C to +70 °C
TS Adapter IE	
Dimensions (W x H x D) in mm	125 x 110 x 40
Weight, approx.	approx. 370 g
Interfaces	<ul style="list-style-type: none"> Ethernet to an external modem to the analog telephone network to the ISDN telephone network
	RJ45 (10/100 Mbit/s) RS 232 (up to 115 kbaud) RJ12 RJ45
Supply voltage, external or via MPI interface	24 V DC
Current consumption of the TSA-IE ISDN	typ. 170 mA / max. 230 mA
Current consumption of the modem TSA IE	typ. 180 mA / max. 240 mA
Switch-on current, max.	0.7 A; 8 µs
Degree of protection	IP20
Temperature	
• Operation	± 0 °C to +60 °C
• Storage/transport	-40 °C to +70 °C
TS Adapter IE Basic (basic unit)	
Dimensions (W x H x D) in mm	30 x 100 x 75
Weight, approx.	100 g
Interfaces	<ul style="list-style-type: none"> Ethernet to the TS module
	RJ45 (10/100 Mbit/s) Proprietary (can only be used for TS modules)
Supply voltage, external	24 V DC
Current consumption	
• With TS module modem	Typ. 50 mA, max. 80 mA
• with TS module ISDN	Typ. 50 mA, max. 80 mA
• with TS module RS232	Typ. 40 mA, max. 60 mA
• with TS module GSM	Typ. 100 mA, max. 180 mA
Switch-on current, max.	240 mA
Degree of protection	IP20
Temperature	
• Operation	± 0 °C to +60 °C (horizontal installation) ± 0 °C to +40 °C (vertical installation)
• Storage	40 °C to +70 °C

TS module modem	
Dimensions (W x H x D) in mm, approximately	30 x 100 x 75
Weight, approx.	98 g
ITU transmission standards	<ul style="list-style-type: none"> V.21, V.22, V.22bis, V.23, V.32, V.32bis, V.34, V.34x, K56flex, V.90, V.92
Other features	<ul style="list-style-type: none"> Error correction and data compression a/b interface Hayes (AT) command set All data formats Dial procedures: dual-tone multiple-frequency (DTMF), pulse dialing
TS module ISDN	
Dimensions (W x H x D) in mm	30 x 100 x 75
Weight, approx.	92 g
Reports	
• D channel protocols	DSS1 (Euro-ISDN), 1TR6
• B channel protocols	V.110 (9600 bit/s, 19200 bit/s, 38400 bit/s) V.120 (64 Kbit/s) X.75 (64 Kbit/s)
Other features	<ul style="list-style-type: none"> Multiple subscriber number (MSN) AT command interpreter
TS module RS232	
Dimensions (W x H x D) in mm	30 x 100 x 75
Weight, approx.	100 g
Operating mode	Full duplex, asynchronous
Signals	TXD, RXD, DSR, CTS, RTS, DTR, DCD
Data transmission rate	2 400 ... 115 200 bit/s
Message frame	8 data bits (LSB first), no parity bit, 1 stop bit
Rule	according to RS232 standard
Connector	D-sub 9-pin, male (PC COMx)
TS module GSM	
Dimensions (W x H x D) in mm	30 x 100 x 75
Weight, approx.	118 g
Transmission rate	
• GPRS Multislot Class 10	
- Up to 2 uplinks	13.4 Kbit/s ... 27 Kbit/s upload gross
- Up to 4 downlinks	40 Kbit/s ... 54 Kbit/s download gross
Interfaces	
• SIM interface	3 V/1.8 V
• Antenna connection	1 x SMA antenna socket (50 Ohm)
Frequency ranges	Quad band: 850, 900, 1800, 1900 MHz
Transmitted output power	2 W at 850 MHz, 900 MHz 1 W at 1800 MHz, 1900 MHz

Software for SIMATIC controllers

Options for diagnostics and service

TeleService

Ordering data	Order No.	Order No.
TeleService, Version 6.1 Task: Remote maintenance by means of wired or radio network Target system: SIMATIC S7-200, SIMATIC S7-300, SIMATIC S7-400, SIMATIC C7 Requirement: TS Adapter (STEP 7 not required) Delivery package: on CD, German, English, French, Spanish, Italian; with electronic documentation Floating License Floating License Upgrade (from each previous version) Software Update Service (requires current software version) ¹⁾	6ES7 842-0CE00-0YE0 6ES7 842-0CE00-0YE4 6ES7 842-0CA01-0YX2	USB cable for parameterizing the TS Adapter II, it can also be used for programming the connected devices. 5 m long 6ES7 901-0AE00-0XA0
TS Adapter II modem With MPI connection and RS 232; 9-pin, male	6ES7 972-0CB35-0XA0	TS Adapter IE Basic Basic unit 6ES7 972-0EB00-0XA0
TS Adapter II ISDN With MPI connection and RS 232; 9-pin, male	6ES7 972-0CC35-0XA0	TS module modem 6ES7 972-0MM00-0XA0
TS Adapter IE modem With Ethernet connection RJ45 (10/100 Mbit/s) and RS 232; 9-pin, male	6ES7 972-0EM00-0XA0	TS module ISDN 6ES7 972-0MD00-0XA0
TS Adapter IE ISDN With Ethernet connection RJ45 (10/100 Mbit/s) and RS 232; 9-pin, male	6ES7 972-0ED00-0XA0	TS module RS232 6ES7 972-0MS00-0XA0
		TS module GSM 6GK7 972-0MG00-0XA0
		S7 mounting rail adapter For mounting the TS Adapter IE Basic on S7-300 mounting rail, width 60 mm 6ES7 972-0SE00-7AA0
		SIMATIC Manual Collection Electronic manuals on DVD, multilingual: LOGO!, SIMADYN, SIMATIC bus components, SIMATIC C7, SIMATIC distributed I/O, SIMATIC HMI, SIMATIC Sensors, SIMATIC NET, SIMATIC PC Based Automation, SIMATIC PCS 7, SIMATIC PG/PC, SIMATIC S7, SIMATIC Software, SIMATIC TDC 6ES7 998-8XC01-8YE0
		SIMATIC Manual Collection update service for 1 year Current "Manual Collection" DVD and the three subsequent updates 6ES7 998-8XC01-8YE2

¹⁾ For more information on the software update service, see page 11/3.

Software for SIMATIC controllers

Options for diagnostics and service

PRODAVE

Overview

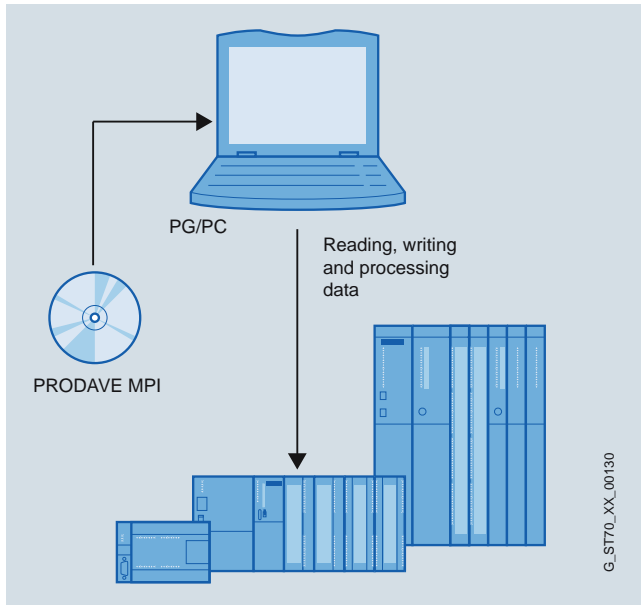

- The toolbox for exchange of process data between SIMATIC S7, SIMATIC C7 and a PG/PC
- For autonomous handling of data traffic over MPI/PPI, PROFIBUS and Industrial Ethernet

Technical specifications

Parameterization software	PRODAVE
Type of license	Simple license, copy license
Software class	A
Current version	V6.2
Target system	SIMATIC S7-200 SIMATIC S7-300 SIMATIC S7-400 SIMATIC C7
Operating system	Windows XP Professional, Windows 7 Professional and Ultimate (32 and 64-bit in each case)
Required software packages	-
Main memory configuration in target system	8 MB on PG/PC
Disk space required in PG/PC	2 MB
Standard FBs	
Required libraries	-

Ordering data

Order No.

PRODAVE MPI/IE V6.2 for Windows XP Professional, Windows 7 Professional and Ultimate (32 and 64-bit in each case)

Task:

Data link between PG/PC and SIMATIC S7/C7 via MPI (S7-200 via PPI) or Industrial Ethernet

Requirements:

Windows XP Professional, Windows 7 Professional and Ultimate (32 and 64-bit in each case); CP 5611, integrated MPI or PC adapter

Delivery package: CD incl. electr. documentation (German, English)

Single license

6ES7 807-4BA03-0YA0

Copy license, without software and documentation

6ES7 807-4BA03-0YA1

PRODAVE MPI Mini V6.0 for Windows 95/98/ME/NT 4.0/2000 Prof./XP Prof.

Task:

Data link between PG/PC and SIMATIC S7/C7 over MPI (S7-200 over PPI); with reduced functional scope)

Requirements:

Windows 95/98/ME/NT 4.0/2000 Prof./XP Prof.; CP 5611, integrated MPI or PC adapter

Delivery package:

CD incl. electr. documentation (German, English)

Single license

6ES7 807-3BA01-0YA0

Copy license, without software and documentation

6ES7 807-3BA01-0YA1

SIMATIC Manual Collection

Electronic manuals on DVD, multilingual: LOGO!, SIMADYN, SIMATIC bus components, SIMATIC C7, SIMATIC distributed I/O, SIMATIC HMI, SIMATIC Sensors, SIMATIC NET, SIMATIC PC Based Automation, SIMATIC PCS 7, SIMATIC PG/PC, SIMATIC S7, SIMATIC Software, SIMATIC TDC

6ES7 998-8XC01-8YE0

SIMATIC Manual Collection update service for 1 year

Current "Manual Collection" DVD and the three subsequent updates

6ES7 998-8XC01-8YE2

Software for SIMATIC controllers

Options for engineering and drive technology

PID Professional V11

Overview

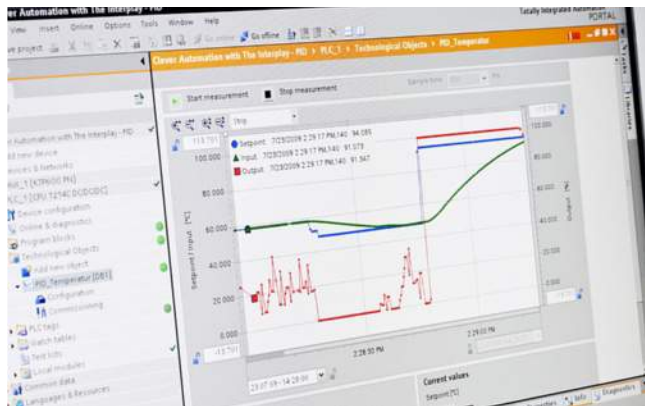

- PID Professional V11 combines the two option packages Modular PID Control and Standard PID Control in the TIA Portal.
- Permits the simple integration of continuous PID controllers, pulse controllers and step controllers in the application program
- Can be used for simple to complex closed-loop control tasks in SIMATIC S7-300 (CPU 313 or higher), S7-400, and WinAC.
- Tuning functionality by means of PID Self-Tuner (part of STEP 7 as of V11 SP1).
- Reduces engineering costs thanks to time-saving parameterization and optimization of the controller

Technical specifications

Parameterization software	PID Professional
Type of license	Single license
Software class	A
Current version	V11
Target system	SIMATIC S7-300 (CPU 313 or higher) SIMATIC S7-400 WinAC
Required software packages	STEP 7 V11 SP2 Update 2 or higher
RAM	1 GB
Disk space required in PG/PC	2 GB
Processor, at least	Pentium M, 1.6 GHz or comparable
Operating systems	<ul style="list-style-type: none"> • Windows XP Professional SP3 • Windows 2003 Server R2 StdE SP2 • Windows 7 (Professional, Enterprise, Ultimate, 32/64 bit) • Windows 2008 Server StdE SP2
Standard FBs in general	
Required libraries	PID Professional V11
Forms of license	Single license and 1 runtime license
Software class	A
Current version	V11
Main memory configuration in PG/PC	16 MB
Disk space required in PG/PC	1.85 MB

Ordering data

PID Professional V11

Task:

Start-up tool for PID controllers

Requirement:

STEP 7 as of V11 SP2 Update 2

Delivery package:

on CD

Floating license for the engineering and blocks

6ES7 860-1XA01-0XA5

Floating license for the engineering and blocks

6ES7 860-1XA01-0XH5

License Key Download without software and documentation²⁾ email address required for delivery

6ES7 860-1XA01-0YL0

Software Update Service (requires current software version)¹⁾

6ES7 860-1XA01-0XE5

Upgrade license from Standard PID Control or Modular PID Control V5.x to PID Professional V11

6ES7 860-1XA01-0XK5

Upgrade license from Standard PID Control or Modular PID Control V5.x to PID Professional V11

License Key Download without software and documentation²⁾ email address required for delivery

6ES7 860-1XA01-0XB0

Single license (certificate of license) for blocks; per CPU

¹⁾ For more information on the software update service, see page 11/3.

²⁾ For up-to-date information and download availability, see: <http://www.siemens.com/tia-online-software-delivery>.

Overview

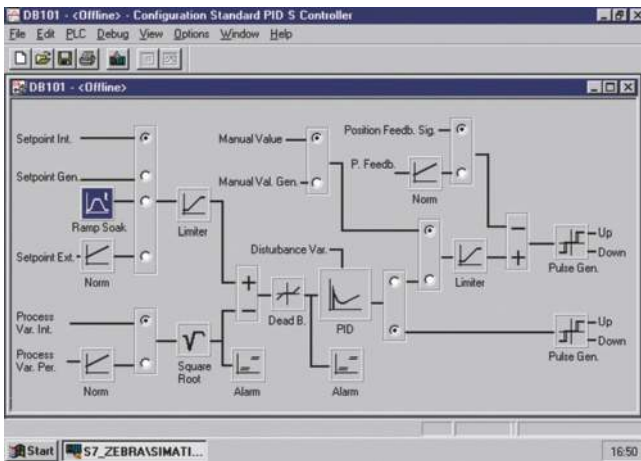

- For integrating continuous PID controllers, pulse controllers and step controllers in the application program
- Reduces engineering costs thanks to time-saving parameterization and optimization of the controller
- For use in SIMATIC S7-300 (CPU 313 or higher), S7-400 and WinAC

Technical specifications

Parameterization software	Standard PID Control					
Type of license	Single license					
Software class	A					
Current version	V 5.2					
Target system	SIMATIC S7-300 (CPU 313 or higher) SIMATIC S7-400 SIMATIC C7					
Required software packages	STEP 7 V5.3 SP2 or higher					
Main memory configuration in PG/PC	16 MB					
Disk space required in PG/PC	1.85 MB					
Standard function blocks	PID_CP (FB 1)		PID_ES (FB 2)		LP_SCHED (FC 1)	
Storage space requirements	Load memory	Work memory	Load memory	Work memory	Load memory	Work memory
• FB length in the memory	8956 bytes	7796 bytes	9104 bytes	7982 bytes	1064 bytes	976 bytes
• DB length in the memory	1168 bytes	510 bytes	1124 bytes	484 bytes	184 bytes ²⁾	100 bytes ²⁾
Runtimes						
• In S7-300 ¹⁾	0.18 - 4.4 ms		0.2 - 5.1 ms		0.03 - 0.3 ms	
• In S7-400 ¹⁾	0.13 - 0.35 ms		0.16 - 0.35 ms		0.03 - 0.08 ms	
Required libraries	Standard PID Control FBs					
Licensing forms	Simple license and 1 runtime license; 1 runtime license					
Software class	A					
Current version	V 5.2					
Target system	SIMATIC S7-300 (CPU 313 or higher) SIMATIC S7-400 SIMATIC C7					
Required software packages	STEP 7 V5.3 SP2 or higher					
Main memory configuration in PG/PC	16 MB					
Disk space required in PG/PC	1.85 MB					

¹⁾ Depending on the CPU

²⁾ With 5 control loops

Software for SIMATIC controllers

Options for engineering and drive technology

Standard PID Control

Ordering data	Order No.	Order No.
Standard PID Control parameterization tool, V5.2 Task: Parameterization tool for standard closed-loop controls Requirement: STEP 7, V5.3 SP2 or higher Delivery package: With electronic manual/Getting Started English, German; incl. authorization diskette Floating license Software Update Service (requires current software version) ¹⁾ Upgrade License from V5.x to V5.2	6ES7 830-2AA22-0YX0 6ES7 830-2AA00-0YX2 6ES7 830-2AA22-0YX4	SIMATIC Manual Collection Electronic manuals on DVD, multilingual: LOGO!, SIMADYN, SIMATIC bus components, SIMATIC C7, SIMATIC distributed I/O, SIMATIC HMI, SIMATIC Sensors, SIMATIC NET, SIMATIC PC Based Automation, SIMATIC PCS 7, SIMATIC PG/PC, SIMATIC S7, SIMATIC Software, SIMATIC TDC SIMATIC Manual Collection update service for 1 year Current "Manual Collection" DVD and the three subsequent updates
Standard function blocks for Standard PID Control, V5.2 Task: Standard FBs for standard closed-loop controls Target system: SIMATIC S7-300 (CPU 313 or higher), S7-400 Type of delivery: With electronic manual/Getting Started English, German Single license Single license without software and documentation	6ES7 860-2AA21-0YX0 6ES7 860-2AA21-0YX1	6ES7 998-8XC01-8YE0 6ES7 998-8XC01-8YE2

¹⁾ For more information on the software update service, see page 11/3.

Software for SIMATIC controllers

Options for engineering and drive technology

Modular PID Control

Overview

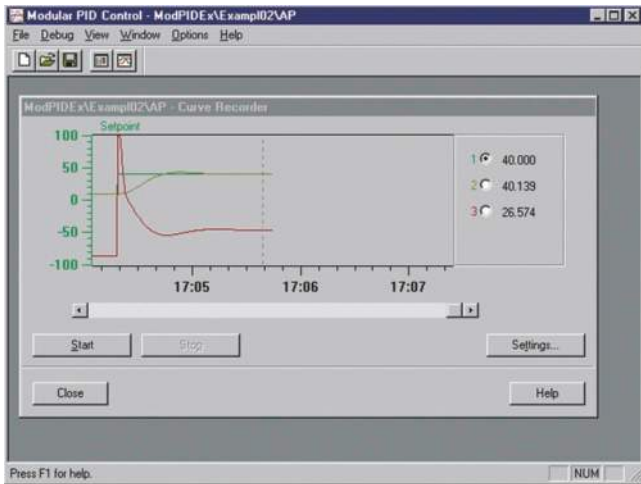

- For creating complex closed-loop control structures
- Preferred for implementation in closed-loop control equipment in mid-range and high-end applications and in process engineering
- For use in SIMATIC S7-300 (CPU 313 or higher), S7-400 and WinAC

Technical specifications

Parameterization software	Modular PID Control
Type of license	Single license
Software class	A
Current version	V 5.1
Target system	SIMATIC S7-300 (CPU 313 or higher) SIMATIC S7-400 SIMATIC C7

Parameterization software	Modular PID Control
Required software packages	STEP 7 V5.3 SP2 or higher
Main memory configuration in PG/PC	16 MB
Disk space required in PG/PC	1.85 MB
Processor, at least	486
Windows swap area, approx.	20 MB (max. possible)

Standard function blocks	A_DEAD_B		CRP_IN		CPR_OUT	
Storage space requirements	Load memory	Work memory	Load memory	Work memory	Load memory	Work memory
• FB length in the memory	898 bytes	692 bytes	182 bytes	70 bytes	206 bytes	96 bytes
• DB length in the memory	186 bytes	44 bytes	122 bytes	20 bytes	114 bytes	14 bytes
Runtimes in S7-300	0.13 to 0.17 ms		0.06 ms		0.18 to 0.22 ms	
Runtimes in S7-400	0.01 to 0.03 ms		0.01 to 0.02 m		0.01 to 0.04 ms	
Target system	SIMATIC S7-300 (CPU 313 and higher), S7-400, WinAC		SIMATIC S7-300 (CPU 313 and higher), S7-400, WinAC		SIMATIC S7-300 (CPU 313 and higher), S7-400, WinAC	

Standard function blocks	DEAD_T		DEAD_BAND		DIF	
Storage space requirements	Load memory	Work memory	Load memory	Work memory	Load memory	Work memory
• FB length in the memory	532 bytes	394 bytes	232 bytes	120 bytes	410 bytes	268 bytes
• DB length in the memory	142 bytes	22 bytes	114 bytes	16 bytes	158 bytes	30 bytes
Runtimes in S7-300	0.26 to 0.33 ms		0.16 to 0.21 ms		0.55 to 0.71 ms	
Runtimes in S7-400	0.02 to 0.06 m		0.01 to 0.03 ms		0.03 to 0.09 ms	
Target system	SIMATIC S7-300 (CPU 313 and higher), S7-400, WinAC		SIMATIC S7-300 (CPU 313 and higher), S7-400, WinAC		SIMATIC S7-300 (CPU 313 and higher), S7-400, WinAC	

Standard function blocks	ERR_MON		INTEG		LAG1ST	
Storage space requirements	Load memory	Work memory	Load memory	Work memory	Load memory	Work memory
• FB length in the memory	558 bytes	360 bytes	488 bytes	314 bytes	534 bytes	368 bytes
• DB length in the memory	206 bytes	52 bytes	168 bytes	36 bytes	156 bytes	30 bytes
Runtimes in S7-300	0.27 to 0.35 ms		0.40 to 0.51 ms		0.52 to 0.67 ms	
Runtimes in S7-400	0.01 to 0.05 ms		0.02 to 0.07 ms		0.03 to 0.09 ms	
Target system	SIMATIC S7-300 (CPU 313 and higher), S7-400, WinAC		SIMATIC S7-300 (CPU 313 and higher), S7-400, WinAC		SIMATIC S7-300 (CPU 313 and higher), S7-400, WinAC	

Software for SIMATIC controllers

Options for engineering and drive technology

Modular PID Control

Technical specifications (continued)

Standard function blocks	LAG2ND		LIMALARM		LIMITER	
Storage space requirements	Load memory	Work memory	Load memory	Work memory	Load memory	Work memory
• FB length in the memory	690 bytes	516 bytes	390 bytes	240 bytes	262 bytes	140 bytes
• DB length in the memory	190 bytes	46 bytes	152 bytes	28 bytes	124 bytes	20 bytes
Runtimes in S7-300	0.88 to 1.14 ms		0.47 to 0.61 ms		0.14 to 0.17 ms	
Runtimes in S7-400	0.04 to 0.16 ms		0.02 to 0.07 ms		0.03 to 0.01 ms	
Target system	SIMATIC S7-300 (CPU 313 and higher), S7-400, WinAC		SIMATIC S7-300 (CPU 313 and higher), S7-400, WinAC		SIMATIC S7-300 (CPU 313 and higher), S7-400, WinAC	

Standard function blocks	LMNGEN_C		LMNGEN_S		NONLIN	
Storage space requirements	Load memory	Work memory	Load memory	Work memory	Load memory	Work memory
• FB length in the memory	1576 bytes	1280 bytes	2578 bytes	2152 bytes	826 bytes	672 bytes
• DB length in the memory	276 bytes	80 bytes	360 bytes	110 bytes	138 bytes	18 bytes
Runtimes in S7-300	0.32 to 0.41 ms		1.16 to 1.47 ms		0.32 to 0.41 ms	
Runtimes in S7-400	0.02 to 0.06 ms		0.06 to 0.18 ms		0.02 to 0.07 ms	
Target system	SIMATIC S7-300 (CPU 313 and higher), S7-400, WinAC		SIMATIC S7-300 (CPU 313 and higher), S7-400, WinAC		SIMATIC S7-300 (CPU 313 and higher), S7-400, WinAC	

Standard function blocks	NORM		OVERRIDE		PARA_CTL	
Storage space requirements	Load memory	Work memory	Load memory	Work memory	Load memory	Work memory
• FB length in the memory	234 bytes	122 bytes	362 bytes	214 bytes	406 bytes	232 bytes
• DB length in the memory	130 bytes	24 bytes	146 bytes	28 bytes	234 bytes	82 bytes
Runtimes in S7-300	0.33 to 0.43 ms		0.15 to 0.18 ms		0.12 to 0.15 ms	
Runtimes in S7-400	0.02 to 0.07 ms		0.01 to 0.04 ms		0.01 to 0.03 ms	
Target system	SIMATIC S7-300 (CPU 313 and higher), S7-400, WinAC		SIMATIC S7-300 (CPU 313 and higher), S7-400, WinAC		SIMATIC S7-300 (CPU 313 and higher), S7-400, WinAC	

Standard function blocks	PID		PULSEGEN		RMP_SOAK	
Storage space requirements	Load memory	Work memory	Load memory	Work memory	Load memory	Work memory
• FB length in the memory	1560 bytes	1242 bytes	1110 bytes	872 bytes	1706 bytes	1500 bytes
• DB length in the memory	340 bytes	98 bytes	190 bytes	34 bytes	212 bytes	62 bytes
Runtimes in S7-300	1.15 to 1.46 ms		0.17 to 0.20 ms		0.16 to 0.20 ms	
Runtimes in S7-400	0.06 to 0.18 ms		0.01 to 0.05 ms		0.01 to 0.04 ms	
Target system	SIMATIC S7-300 (CPU 313 and higher), S7-400, WinAC		SIMATIC S7-300 (CPU 313 and higher), S7-400, WinAC		SIMATIC S7-300 (CPU 313 and higher), S7-400, WinAC	

Standard function blocks	ROC_LIM		SCALE		SP_GEN	
Storage space requirements	Load memory	Work memory	Load memory	Work memory	Load memory	Work memory
• FB length in the memory	1242 bytes	980 bytes	136 bytes	32 bytes	658 bytes	484 bytes
• DB length in the memory	222 bytes	50 bytes	114 bytes	16 bytes	164 bytes	40 bytes
Runtimes in S7-300	0.53 to 0.68 ms		0.10 to 0.13 ms		0.27 to 0.35 ms	
Runtimes in S7-400	0.02 to 0.09 ms		0.01 to 0.02 ms		0.02 to 0.06 ms	
Target system	SIMATIC S7-300 (CPU 313 and higher), S7-400, WinAC		SIMATIC S7-300 (CPU 313 and higher), S7-400, WinAC		SIMATIC S7-300 (CPU 313 and higher), S7-400, WinAC	

Technical specifications (continued)

Standard function blocks	SPLT_RAN		SWITCH		LP_SCHED	
Storage space requirements	Load memory	Work memory	Load memory	Work memory	Load memory	Work memory
• FB length in the memory	304 bytes	180 bytes	238 bytes	116 bytes	1104 bytes	972 bytes ¹⁾
• DB length in the memory	138 bytes	28 bytes	118 bytes	18 bytes	234 bytes	64 bytes ¹⁾
Runtimes in S7-300	0.09 to 0.11 ms		0.07 to 0.09 ms		0.28 to 0.34 ms	
Runtimes in S7-400	0.01 to 0.02 ms		0.01 to 0.03 ms		0.03 to 0.08 ms	
Target system	SIMATIC S7-300 (CPU 313 and higher), S7-400, WinAC		SIMATIC S7-300 (CPU 313 and higher), S7-400, WinAC		SIMATIC S7-300 (CPU 313 and higher), S7-400, WinAC	

¹⁾ With 5 control loops

Standard FBs in general		Standard FBs in general	
Required libraries	Modular PID Control FBs	Current version	V 5.1
Licensing forms	Simple license and 1 runtime license; 1 runtime license	Required software packages	STEP 7 V5.3 SP2 or higher
Software class	A	Main memory configuration in PG/PC	16 MB
		Disk space required in PG/PC	1.85 MB

Ordering data

Ordering data	Order No.	Ordering data	Order No.
Modular PID Control commissioning tool, V5.1 for SIMATIC S7 and WinAC Task: Start-up tool for modular PID controllers Requirement: STEP 7, V5.3 SP2 or higher Delivery package: With electronic manual, English, German; incl. authorization diskette Floating license	6ES7 830-1AA11-0YX0 6ES7 830-1AA00-0YX2 6ES7 830-1AA11-0YX4	SIMATIC Manual Collection Electronic manuals on DVD, multilingual: LOGO!, SIMADYN, SIMATIC bus components, SIMATIC C7, SIMATIC distributed I/O, SIMATIC HMI, SIMATIC Sensors, SIMATIC NET, SIMATIC PC Based Automation, SIMATIC PCS 7, SIMATIC PG/PC, SIMATIC S7, SIMATIC Software, SIMATIC TDC	6ES7 998-8XC01-8YE0 6ES7 998-8XC01-8YE2
Software Update Service (requires current software version) ¹⁾ Upgrade License from V5.0 to V5.1		SIMATIC Manual Collection update service for 1 year Current "Manual Collection" DVD and the three subsequent updates	
Standard function blocks for Modular PID Control, V5.1 Task: Standard FBs for modular PID controllers Target system: SIMATIC S7-300 (CPU 313 or higher), S7-400, WinAC Type of delivery: English, German; with electronic manual Single license	6ES7 860-1AA10-0YX0 6ES7 860-1AA10-0YX1		
Single license, without software and documentation			

¹⁾ For more information on the software update service, see page 11/3.

Software for SIMATIC controllers

Options for engineering and drive technology

PID Self-Tuner

Overview

- PID Self-Tuner: For expanding existing PID controllers to create self-tuning PI or PID controllers.
- Optimization of PI or PID controllers with 3-step action (HEATING – OFF – COOLING)
- Convenient online initial setting and online adaptation during operation
- Ideally applicable to temperature controllers, but also suitable for level and flow controllers
- Can be used with SIMATIC S7-300 (CPU 313 or higher), SIMATIC S7-400 and WinAC; in combination with PID control (integrated in STEP 7), Standard PID Control, Modular PID Control, FM 355, FM 455 as well as with any PID algorithm

Technical specifications

Parameterization software	PID Self-Tuner			
Type of license	-			
Software class	-			
Current version	-			
Target system	-			
Operating system	-			
Required software packages	-			
Main memory configuration in PG/PC	-			
Disk space required in PG/PC	-			
Standard FBs	-			
PID Self-Tuner	TUN_EC		TUN_ES	
Storage space requirements	Load memory	Work memory	Load memory	Work memory
• FB length in the memory	approx. 6542 bytes	approx. 5956 bytes	6332 bytes	5714 bytes
• DB length in the memory	644 bytes	294 bytes	638 bytes	288 bytes
Runtimes				
• In S7-300	1.0 ms to 1.5 ms ¹⁾		1.0 ms to 1.5 ms ¹⁾	
• In S7-400	0.06 ms to 0.19 ms ¹⁾		0.06 ms to 0.19 ms ¹⁾	
Required libraries	PID Self-Tuner FBs V5.0			
Licensing forms	-			
Software class	A			
Current version	V5.0			
Target system	SIMATIC S7-300 (CPU 313 or higher) SIMATIC S7-400 SIMATIC C7-620			
Required software packages	STEP 7 V3.2 or higher			
Main memory configuration in PG/PC	-			
Disk space required in PG/PC	-			

¹⁾ Depending on the CPU selected

Ordering data

PID Self Tuner V5.1

Task:
Online optimization for PID controller
PLC:
SIMATIC S7-300 (CPU 313 or higher), S7-400, WinAC
Type of delivery:
Standard function blocks, electronic manual and Getting Started (German/English);
Single license
Single license, without software and documentation

Order No.

6ES7 860-4AA01-0YX0

6ES7 860-4AA01-0YX1

SIMATIC Manual Collection

Electronic manuals on DVD, multilingual: LOGO!, SIMADYN, SIMATIC bus components, SIMATIC C7, SIMATIC distributed I/O, SIMATIC HMI, SIMATIC Sensors, SIMATIC NET, SIMATIC PC Based Automation, SIMATIC PCS 7, SIMATIC PG/PC, SIMATIC S7, SIMATIC Software, SIMATIC TDC

SIMATIC Manual Collection update service for 1 year

Current "Manual Collection" DVD and the three subsequent updates

Order No.

6ES7 998-8XC01-8YE0

6ES7 998-8XC01-8YE2

Overview

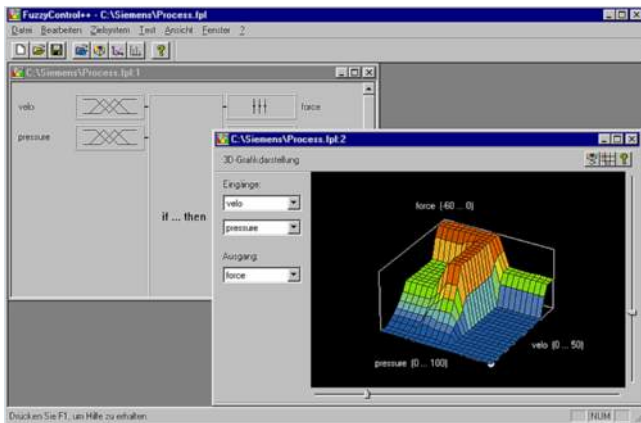

- For creating Fuzzy systems for SIMATIC S7 and SIMATIC WinCC
- For use at all levels of automation from the standalone controller through to plant optimization
- Can be combined with classical PID controllers to utilize the advantages of both systems for optimized closed-loop control

Technical specifications

Technical data for configuration tool	
Parameterization software	Fuzzy Control++
Type of license	Single license
Target system	SIMATIC S7-300 (CPU 314 or higher), SIMATIC S7-400
Processor	PC or PG with 80486 processor (or higher)

Technical data for configuration tool	
Main memory, min.	16 MB work memory (RAM)
Hard disk, min.	5 MB free memory on the hard disk
Operating system	Windows 95 or Windows NT 4.0

Technical data for standard function blocks			
	FUZZY_4K (FB 30)	FUZZY_20K (FB 31)	FUZZY_WinCC
Target system	SIMATIC S7-300 (CPU 314 or higher), SIMATIC S7-400	SIMATIC S7-400	SIMATIC WinCC
Communication PC/PG-S7	MPI bus, SOFTNET S7 for PROFIBUS	MPI bus, SOFTNET S7 for PROFIBUS	Not required
Runtimes	Depending on the number of rules, inputs and outputs: 13 up to 180 ms (S7-300), 1.8 up to 22 ms (S7-400)	Depending on the number of rules, inputs and outputs: 1.8 up to 150 ms (S7-400)	not measurable
Memory requirement	<ul style="list-style-type: none"> • FB 1524 bytes • DB 4228 bytes 	<ul style="list-style-type: none"> 1524 bytes 20612 bytes 	not measurable
Number of inputs	8 with max. 7 association functions each	8 with max. 7 association functions each	8 with max. 7 association functions each
Number of outputs	4 with max. 9 association functions each	4 with max. 9 association functions each	4 with max. 9 association functions each
Number of rules, max.	200	2000	2000
Required libraries	Fuzzy Control++ FBs		
Licensing forms	Single license		
Software class	A		
Current version	V 4.0		
Operating system	Windows 95/NT		
Main memory configuration in PG/PC	16 MB on PG/PC		
Disk space required in PG/PC	5 MB		

Software for SIMATIC controllers

Options for engineering and drive technology

Fuzzy Control

Ordering data	Order No.		Order No.
Fuzzy Control++ configuration tool Function blocks for S7-300/400 CPU 314 and higher incl. SmartObject for SIMATIC WinCC, manual; single license Basic license Copy license	2XV9 450-1WC10-0AA1 2XV9450-1WC11-4XA0	SIMATIC Manual Collection Electronic manuals on DVD, multilingual: LOGO!, SIMADYN, SIMATIC bus components, SIMATIC C7, SIMATIC distributed I/O, SIMATIC HMI, SIMATIC Sensors, SIMATIC NET, SIMATIC PC Based Automation, SIMATIC PCS 7, SIMATIC PG/PC, SIMATIC S7, SIMATIC Software, SIMATIC TDC	6ES7 998-8XC01-8YE0
		SIMATIC Manual Collection update service for 1 year Current "Manual Collection" DVD and the three subsequent updates	6ES7 998-8XC01-8YE2

Overview

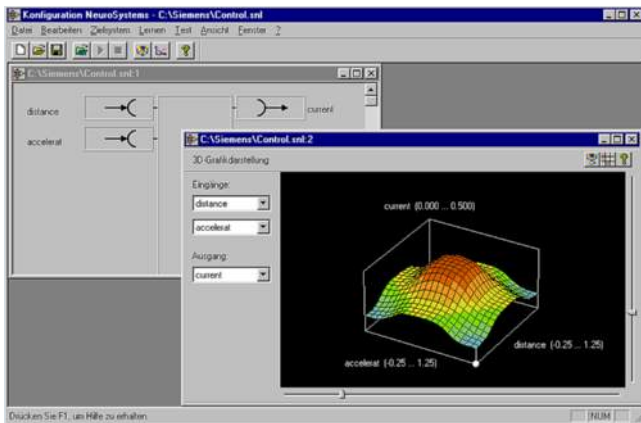

- For creating and teaching neuronal networks
- For use with problems whose structure and solution are only partially known
- Applications:
 - Data-based optimization
 - Identification of characteristics or processes
 - Filtering of data
 - Data evaluation and interpretation
 - Non-linear single and multiple-variable closed-loop control
 - Pattern recognition and diagnostics

Technical specifications

Technical data for configuration tool	
Parameterization software	Neuro systems
Type of license	Single license
Target system	SIMATIC S7-300 (CPU 314 or higher) SIMATIC S7-400
Processor	PC or PG with 80486 processor (or higher)

Technical data for configuration tool	
Main memory, min.	16 MB work memory (RAM)
Hard disk, min.	5 MB free memory on the hard disk
Operating system	Windows 95 or Windows NT 4.0

Technical data for standard function blocks			
	NEURO_4K (FB 100)	NEURO_20K (FB 101)	NEURO_WinCC
Target system	SIMATIC S7-300 (CPU 314 or higher), SIMATIC S7-400	SIMATIC S7-400	SIMATIC WinCC
Communication PC/PG-S7	MPI bus, SOFTNET S7 for PROFIBUS	MPI bus, SOFTNET S7 for PROFIBUS	Not required
Runtimes	Depending on the number of inputs, outputs and neurons: 6.5 up to 270 ms (S7-300) 3.3 up to 140 ms (S7-400)	Depending on the number of inputs, outputs and neurons: 3.3 up to 260 ms (S7-400)	not measurable
Memory requirement	• FB • DB		
	2246 bytes 4278 bytes	2210 bytes 20612 bytes	not measurable
Number of inputs, max.	4	100	10
Number of outputs, max.	4	10	10
Line supply types	MLP, RBF, neuro-fuzzy	MLP, RBF, neuro-fuzzy	MLP, RBF, neuro-fuzzy
Required libraries	Neuro systems FBs		
Licensing forms	Single license		
Operating system	Windows 95/NT		
Main memory configuration in PG/PC	16 MB on PG/PC		
Disk space required in PG/PC	5 MB		

Software for SIMATIC controllers

Options for engineering and drive technology

NeuroSystems

Ordering data	Order No.		Order No.
NeuroSystems configuration tool Function blocks for S7-300/400 CPU 314 and higher incl. SmartObject for SIMATIC single license Basic license Copy license	2XV9 450-1WC15-0AA0 2XV9 450-1WC16-4XA0	SIMATIC Manual Collection Electronic manuals on DVD, multilingual: LOGO!, SIMADYN, SIMATIC bus components, SIMATIC C7, SIMATIC distributed I/O, SIMATIC HMI, SIMATIC Sensors, SIMATIC NET, SIMATIC PC Based Automation, SIMATIC PCS 7, SIMATIC PG/PC, SIMATIC S7, SIMATIC Software, SIMATIC TDC	6ES7 998-8XC01-8YE0
		SIMATIC Manual Collection update service for 1 year Current "Manual Collection" DVD and the three subsequent updates	6ES7 998-8XC01-8YE2

Software for SIMATIC controllers

Options for engineering and drive technology

S7-Technology

Overview

- Option package for creating motion control tasks for CPU 31xT-2 DP and CPU 317TF-2 DP
- Optimal embedding in the automation world thanks to total integration in the STEP 7 tools
- Programming in the standard SIMATIC programming languages LAD, FBD and STL
- Additional Engineering Tools such as S7-SCL or S7-GRAPH can be used

Ordering data

Order No.

S7-Technology V4.2

Task:

Option package for configuring and programming technology tasks with SIMATIC S7 CPU 31xT-2 DP and the SIMATIC S7 CPU 317TF-2 DP

Requirement:

STEP 7 V5.5 SP2 or higher

Delivery package:

on DVD;
incl. documentation for
CPU 31xT-2 DP, CPU 317TF-2 DP
(included on DVD)

Floating license

6ES7 864-1CC42-0YA5

Upgrade to V4.2

6ES7 864-1CC42-0YE5

Trial License

6ES7 864-1CC42-0YA7

Software for SIMATIC controllers

Options for engineering and drive technology

Easy Motion Control

Overview

- Low-priced package for simple, controlled positioning and simple geared synchronous motion
- For use with any standard variable-speed drive, such as frequency converter or servo drive
- For incremental and absolute encoders

Technical specifications

Supported hardware:

Easy Motion Control is runnable on the following CPUs:

- S7-300.
- S7-400.
- WinAC.
- ET 200S.
- ET 200pro.

Supported modules for the measuring of actual values:

- CPU 314C (FW version 2.0 of the CPU or higher).
- ET 200S 1 Count 5V/500 kHz.
- ET 200S 1 Count 24V/100kHz.
- ET 200S 1SSI.
- SM 338.

- FM 350-1, FM 450-1.
- SIMODRIVE sensor with PROFIBUS DP.
- IM 174.
- Other modules for measuring actual values (using free driver).

Supported modules for setpoint output:

- ET 200S 2AO U.
- SM 332.
- SM 432.
- IM 174.
- Other modules for setpoint output (using free driver).

Supported drives using PROFIBUS DP:

- Micromaster 4.
- SINAMICS G120.
- SINAMICS S120.

Storage space requirements

Required main storage in byte		
Block	Required main storage per block	Additional main storage required per instance
MC_Init	1086	-
MC_MoveAbsolute	3924	112
MC_MoveRelative	2982	110
MC_MoveJog	3110	110
MC_Home	2886	104
MC_StopMotion	1114	70
MC_Control	1756	58
MC_Simulation	410	64
MC_GearIn	3476	128
Input driver	1416 ... 2654	76 ... 128
Output driver	384 ... 1242	52 ... 68
Axis data block	-	294

Technical specifications (continued)

Runtime load

Typical runtimes of the blocks in µs				
Block	CPU 416-2 DP 6ES7 416-2XK02-0AB0	CPU 314C 6ES7 314-6CF00-0AB0	CPU 315-2 DP 6ES7 315-2AF03-0AB0	WinLC RTX 3.1 on AMD, 1333 MHz
MC_Init	53	967	2203	21
MC_MoveAbsolute 1)	67	908	2138	18
MC_MoveRelative 1)	67	911	2143	18
MC_MoveJog 1)	48	605	1387	15
MC_Home 1)	49	592	1332	15
MC_StopMotion 1)	23	309	696	8
MC_Control	27	343	819	11
MC_Simulation	23	259	584	6
MC_GearIn	66	931	2130	21
Input driver	50	662	1323	44
Output driver	20	223	413	31

¹⁾ The highlighted travel blocks require more runtime once at the start of a trip. For more information please consult the manual.

Ordering data

Easy Motion Control V2.1

Task:
Controlled positioning with
standard variable-speed drives
Requirement:
STEP 7 V5.3 SP2
Delivery package:
incl. software and documentation
(German, English), on CD
Single license

Order No.

6ES7 864-0AC01-0YX0

Easy Motion Control V11

Task:
Controlled positioning with
standard variable-speed drives
Requirement:
STEP 7 V11 SP2
Delivery package:
incl. software and documentation
(German, English), on CD, license
key on USB stick
Single license
Single License, license key
download without software and
documentation ¹⁾;
E-mail address required for delivery

Order No.

6ES7 864-2XA01-0XA5
6ES7 864-2XA01-0XH5

Easy Motion Control without software and documentation

Type of delivery:
CoL for one runtime license
(valid for Easy Motion Control V2.x
and V11)
Single license, without software and
documentation

6ES7 864-0AF01-0YX0

¹⁾ For up-to-date information and download availability, see:
<http://www.siemens.com/tia-online-software-delivery>.

Software for SIMATIC controllers

Options for engineering and drive technology

D7-SYS

Overview

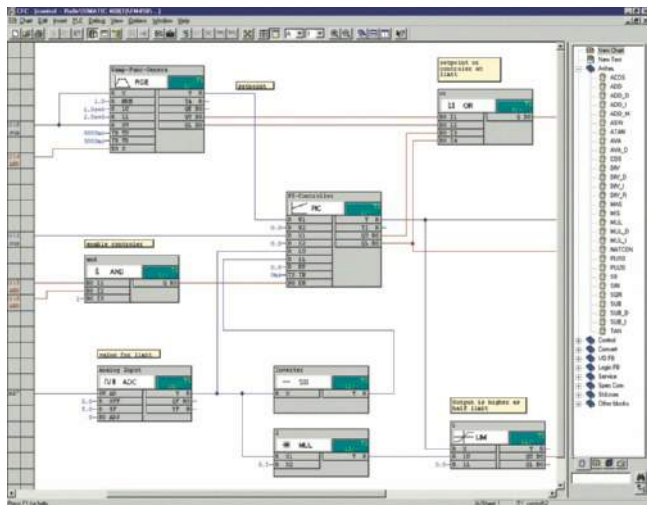

- Add-on for STEP 7/CFC/SFC for configuration of control and automation tasks with T400, FM 458, SIMADYN D or SIMATIC TDC
- Contains function blocks for every application
- Scope of delivery: Software packages D7-SYS, CFC, SFC, TH-PO
- Optional: D7-FB-Gen, function block generator for the creation of customized function blocks

Ordering data

Order No.

SIMATIC D7-SYS V8.0

Task:
Function block library for configuring closed-loop control and automation tasks

Target system:

SIMATIC S7-400/FM 458/
SIMATIC TDC/T400/SIMADYN

Requirement:

Windows XP, Windows 7 32/64-bit,
Windows Server 2003/2008

Type of delivery:

on CD, German, English,
with electronic documentation

Floating license

6ES7 852-0CC03-0YA5

Upgrade License V7.x and higher

6ES7 852-0CC03-0YE5

Software Update Service¹⁾

6ES7 852-0CC01-0YL5

SIMATIC D7 FB Gen V2.1

6DD1 805-5DA0

Function block generator

SIMATIC Manual Collection

6ES7 998-8XC01-8YE0

Electronic manuals on DVD,
multilingual: LOGO!, SIMADYN,
SIMATIC bus components,
SIMATIC C7,
SIMATIC distributed I/O,
SIMATIC HMI,
SIMATIC Sensors,
SIMATIC NET,
SIMATIC PC Based Automation,
SIMATIC PCS 7,
SIMATIC PG/PC,
SIMATIC S7,
SIMATIC Software,
SIMATIC TDC

SIMATIC Manual Collection update service for 1 year

6ES7 998-8XC01-8YE2

Current "Manual Collection" DVD
and the three subsequent updates

¹⁾ For more information on the software update service, see page 11/3.

Software for SIMATIC controllers

Options for engineering and drive technology

Drive ES engineering software

Overview

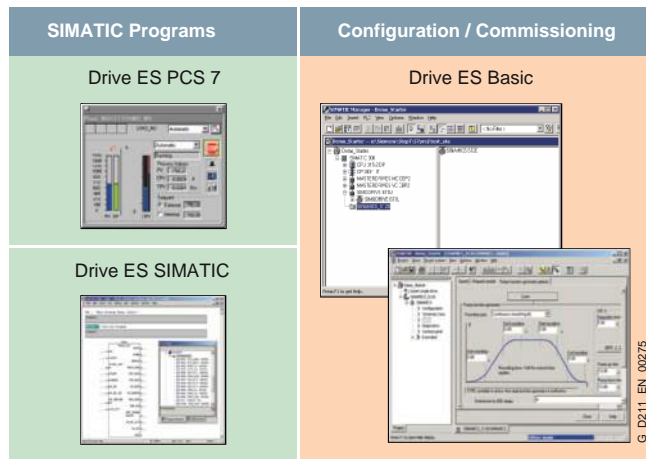

Drive ES is the engineering system used to integrate Siemens drive technology into the SIMATIC automation world easily, efficiently and cost-effectively in terms of communication, configuration and data management.

It is based on the operator interface of the STEP 7 Manager, the essential element when it comes to engineering.

Ordering data

Order No.

Drive ES PCS 7 V6.1 SPx ^{*)}

Function block library for PCS 7 for the integration of drives
Precondition: PCS 7 V6.1 and higher

Supplied as: CD-ROM
Languages: Eng, Fr, Ger, It, Sp with electronic documentation

- Single-user license incl. 1 runtime license
- Runtime license (without data carrier)
- Update service for single-user license

6SW1700-6JD00-1AA0

6SW1700-5JD00-1AC0

6SW1700-0JD00-0AB2

Drive ES PCS 7 V7.0 SPx ^{*)}

Function block library for PCS 7 for the integration of drives

Precondition: PCS 7 V7.0 and higher

Supplied as: CD-ROM
Languages: Eng, Fr, Ger, It, Sp with electronic documentation

- Single-user license incl. 1 runtime license
- Runtime license (without data carrier)
- Update service for single-user license
- Upgrade from V5.x to V7.0 SPx ^{*)}

6SW1700-7JD00-0AA0

6SW1700-5JD00-1AC0

6SW1700-0JD00-0AB2

6SW1700-7JD00-0AA4

Drive ES PCS 7 V7.1 SPx ^{*)}

Function block library for PCS 7 for the integration of drives

Precondition: PCS 7 V7.1 and higher

Supplied as: CD-ROM
Languages: Eng, Fr, Ger, It, Sp with electronic documentation

- Single-user license incl. 1 runtime license
- Runtime license (without data carrier)
- Update service for single-user license
- Upgrade from V6.x to V7.1 SPx ^{*)}

6SW1700-7JD00-1AA0

6SW1700-5JD00-1AC0

6SW1700-0JD00-0AB2

6SW1700-7JD00-1AA4

Drive ES PCS 7 V8.0 SPx ^{*)}

PCS 7 block library for drive integration in classic style (as predecessor)
Precondition: PCS 7 V8.0 and higher

Supplied as: CD-ROM
Languages: Eng, Fr, Ger, It, Sp with electronic documentation

- Single-user license incl. 1 runtime license
- Runtime License (without data carrier)
- Update service for single-user license
- Upgrade from V6.x to V8.0 SPx ^{*)}

6SW1700-8JD00-0AA0

6SW1700-5JD00-1AC0

6SW1700-0JD00-0AB2

6SW1700-8JD00-0AA4

Drive ES PCS 7 APL V8.0 SPx ^{*)}

PCS 7 block library for drive integration in APL style
Precondition: PCS 7 V8.0 and higher

Supplied as: CD-ROM
Languages: Eng, Fr, Ger, It, Sp with electronic documentation

- Single-user license incl. 1 runtime license
- Runtime License (without data carrier)
- Update service for single-user license

6SW1700-8JD01-0AA0

6SW1700-5JD00-1AC0

6SW1700-0JD00-0AB2

Ordering data

Order No.

Drive ES Basic V5.5 SPx ^{*)}

Configuration software for the integration of drives into TIA (Totally Integrated Automation)

Precondition: STEP 7 from V5.3, SP3 and higher

Supplied as: DVD
Languages: Eng, Fr, Ger, It, Sp with electronic documentation

- Floating license, 1 user
- Floating license (copy license), 60 users
- Update service for single-user license
- Update service for copy license, 60 users
- Upgrade from V5.x to V5.5 SPx ^{*)}

6SW1700-5JA00-5AA0

6SW1700-5JA00-5AA1

6SW1700-0JA00-0AB2

6SW1700-0JA00-1AB2

6SW1700-5JA00-5AA4

Drive ES SIMATIC V5.5 SPx ^{*)}

Function block library for SIMATIC for the parameterization of communication with the drives

Precondition: STEP 7 from V5.3, SP3 and higher

Supplied as: CD-ROM
Languages: Eng, Fr, Ger, It, Sp with electronic documentation

- Single-user license incl. 1 runtime license
- Runtime license (without data carrier)
- Upgrade from V5.x to V5.5 SPx ^{*)}

6SW1700-5JC00-5AA0

6SW1700-5JC00-1AC0

6SW1700-5JC00-5AA4

^{*)} Orders are always automatically supplied with the latest SP.

Software for SIMATIC controllers

Software for joint tasks in the documentation sector

Technical product data for CAx applications

Overview

The DVD "Technical Product Data for CAx Applications – Industrial Automation System" contains technical product data for ca. 1,400 products from the following families:

- S7-300 / S7-400
- C7
- Bus components
- ET 200M / S / iS / iSP / X / eco / ecoPN / pro / L
- Communication / Networks

Ordering data

Technical product data for CAx applications

Task:
Product data for use in CAD/CAE applications

One Off License

Order No.

6ES7 991-0CD01-0YX0

Software for SIMATIC controllers

Software for joint tasks in the maintenance sector

SIMATIC Maintenance Station

Overview

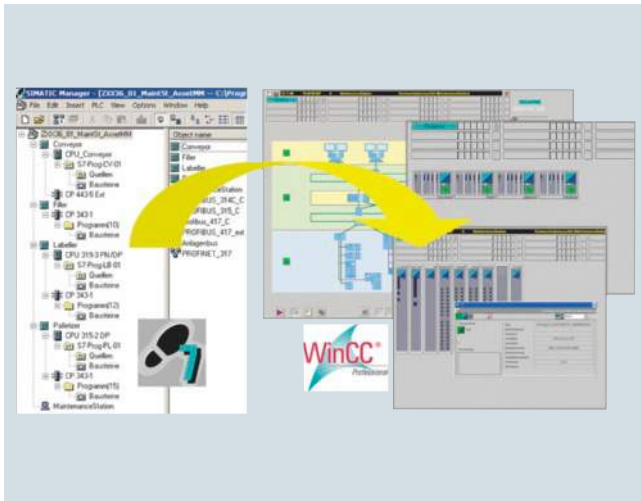

System-integrated plant asset management system

- Automatic generation of a maintenance view in WinCC from the STEP 7 hardware configuration
- Plant-wide visualization of all automation components from the management level to the field level in ready linked, hierarchically arranged WinCC displays
- Mapping of central and distributed SIMATIC S7 components, PROFIBUS and PROFINET networks as well as associated bus nodes
- Ethernet network components and industrial PCs can be integrated through SIMATIC NET SNMP OPC Server
- Display of device status with group status generation in overview and detail displays
- The device statuses "Maintenance required" and "Maintenance request" are supported for status-based maintenance
- Provision of uniform faceplates showing detailed information for all components displayed
- Display of the device identification data (electronic rating plate)
- Integrated display of the status of the request

Technical specifications

Hardware requirements

System	Clock frequency	Main memory	Free hard disk space
Engineering station	2.8 GHz	1 GB	15 GB
Maintenance Station Stand-alone / WinCC-Station "Single-user Workstation"	2.8 GHz	1 GB	15 GB
Maintenance Station Server / WinCC Server	2.8 GHz	1 GB	15 GB
Maintenance Station Client / WinCC Client	2.8 GHz	512 MB	3 GB

Software requirements

System	Operating system
Engineering station "ES"	Windows XP Professional SP2 Windows Server 2003 SP1
Maintenance Station Stand-alone / WinCC-Station "Single-user Workstation"	Windows XP Professional SP2 Windows Server 2003 SP1
ES with Maintenance Station Stand-alone	Windows XP Professional SP2 Windows Server 2003 SP1
Maintenance Station Server / WinCC Server	Windows Server 2003 SP1
Maintenance Station Client / WinCC Client	Windows XP Professional SP2 Windows Server 2003 SP1

Software for SIMATIC controllers

Software for joint tasks in the maintenance sector

SIMATIC Maintenance Station

Technical specifications (continued)

Requirements for the integration of devices

Type	Integration	Comment
SIMATIC S7 controllers / I/O <ul style="list-style-type: none"> • S7-300 ¹⁾ • S7-400 • WinAC 	Yes Yes Yes	
Distributed devices <ul style="list-style-type: none"> • ET 200 • PROFIBUS standard slaves • PROFINET standard devices 	Yes Yes Yes	PROFIBUS DP and PROFINET IO according to STEP 7 hardware catalog Integration using a GSD file Integration using a GSD file
Network components <ul style="list-style-type: none"> Ethernet network components PROFINET network components PROFIBUS diagnostic repeater 	Yes Yes Yes	SIMATIC NET SNMP OPC Server and MIB also required
Personal Computer <ul style="list-style-type: none"> PC/Industrial PC 	Yes	SIMATIC NET SNMP OPC Server also required
Drives <ul style="list-style-type: none"> Drives with PROFIBUS connection Drives with PROFINET connection 	Yes Yes	For integrating devices designed to the PROFIDRIVE profile, Drive ES SIMATIC (V5.4 SP1 or higher) is required For integrating devices designed to the PROFIDRIVE profile, Drive ES SIMATIC (V5.4 SP1 or higher) is required
Accessory devices <ul style="list-style-type: none"> Devices not configured in STEP 7 Hardware Config 	Yes	Integrated via function block (asset proxy)

¹⁾ With S7-300, PROFIBUS/PROFINET systems are supported if they are connected to the internal CPU interfaces

Ordering data

SIMATIC Maintenance Station 2009

Can be used with STEP 7 V5.4 or higher and WinCC V7

- Basic package with engineering software (Floating License) and Runtime License for 100 devices
- Powerpack 100 Runtime License for 100 additional devices

Order No.

6ES7 840-0WD01-0YA0

6ES7 840-0WD11-0YD0

Order No.

6ES7 840-0WD21-0YD0

6ES7 840-0WD31-0YD0

6ES7 840-0WD01-0YA7
6ES7 840-0WD01-0YE0

- Powerpack 500 Runtime License for 500 additional devices
- Powerpack 1000 Runtime License for 1000 additional devices
- Basic demo package 2009
- Upgrade from SIMATIC Maintenance Station 2007 to SIMATIC Maintenance Station 2009

Overview

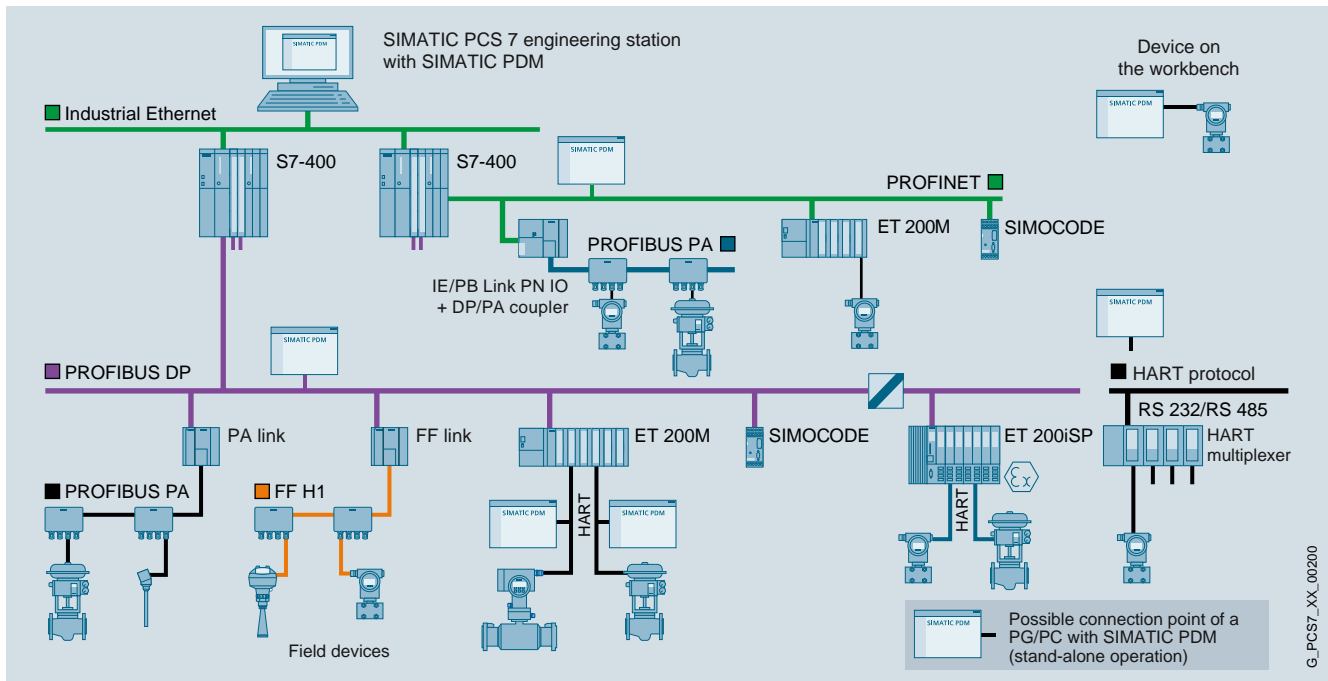

Configuration options with SIMATIC PDM

SIMATIC PDM (Process Device Manager) is a universal, vendor-independent tool for the configuration, parameter assignment, commissioning, diagnostics and servicing of intelligent field devices (sensors and actuators) and field components (remote I/Os, multiplexers, control-room devices, compact controllers), which in the following sections will be referred to simply as devices.

Using *one* software, SIMATIC PDM enables the processing of more than 2 500 devices from Siemens and over 200 vendors worldwide on *one* homogeneous user interface.

The user interface satisfies the requirements of the VDI/VDE GMA 2187 and IEC 65/349/CD directives. Parameters and functions for all supported devices are displayed in a consistent and uniform fashion independent of their communications interface. Even complex devices with several hundred parameters can be represented clearly and processed quickly. Using SIMATIC PDM it is very easy to navigate in highly complex stations such as remote I/Os and even connected field devices.

From the viewpoint of device integration, SIMATIC PDM is the most powerful open device manager available in the world. Devices which previously were not supported can be easily integrated in SIMATIC PDM at any time by importing their device descriptions (EDD). This provides security for your investment and saves you investment costs, training expenses and follow-up costs.

SIMATIC PDM supports the operative system management in particular through:

- Uniform presentation and operation of devices
- Indicators for preventive maintenance and servicing
- Detection of changes in the project and device
- Increasing the operational reliability
- Reducing the investment, operating and maintenance costs
- Graded user privileges including password protection

When used in SIMATIC PCS 7, SIMATIC PDM is integrated in the asset management of the process control system. You can change directly to the SIMATIC PDM views from the diagnostics faceplates in the Maintenance Station.

The Process Device Manager provides more detailed information for all devices described by means of an Electronic Device Description (EDD), e.g.:

- Detailed diagnostics information (manufacturer information, information on error diagnostics and troubleshooting, further documentation)
- Information on changes (audit trail report)
- Parameter information

Software for SIMATIC controllers

Software for joint tasks in the maintenance sector

SIMATIC PDM

Technical specifications

	SIMATIC PDM V6.1	SIMATIC PDM V8.0
Hardware	<ul style="list-style-type: none"> PG/PC/notebook with processor corresponding to operating system requirements 	<ul style="list-style-type: none"> PG/PC/notebook with processor corresponding to operating system requirements
Operating systems (alternative)	<ul style="list-style-type: none"> Microsoft Windows XP Professional SP3, 32-bit Microsoft Windows Server 2003 R2 SP2, Standard Edition 	<ul style="list-style-type: none"> Windows XP Ebedded Standard 2009 Windows XP Professional SP3 (32-bit) Windows Server 2003 SP2 Standard Edition (32-bit) Windows Server 2003 R2 SP2 Standard Edition (32-bit) Windows 7 Enterprise/Ultimate SP1 (32-bit/64-bit) Windows Server 2008 SP2 Standard Edition (32-bit) Windows Server 2008 R2 SP1 Standard Edition (64-bit)
Integration in STEP 7 / PCS 7	<ul style="list-style-type: none"> STEP 7 V5.3+SP2 STEP 7 V5.4+SP5 STEP 7 V5.5 or V5.5+SP1/SP2 SIMATIC PCS 7 V6.1+SP4 SIMATIC PCS 7 V7.1 or V7.1+SP1/SP2/SP3 SIMATIC PCS 7 V8.0 	<ul style="list-style-type: none"> SIMATIC PCS 7 V8.0 STEP 7 V5.5+SP2

Ordering data

Order No.

Order No.

Selection and order data for TIA applications with SIMATIC PDM V6.1

Product packages

Minimum configuration

SIMATIC PDM Single Point V6.1
for operation and configuration of one field device; communication via PROFIBUS DP/PA, HART modem or Modbus, including 1 TAG

cannot be expanded with respect to functions or with TAG option/Power-Pack

6 languages (German, English, French, Italian, Spanish, Chinese), software class A, runs with Windows XP Professional/ Server 2003, floating license for 1 user

Delivery package: License key memory stick, Certificate of License including Terms and Conditions; software SIMATIC PDM V6.1 and device library on CD/DVD

6ES7 658-3HX16-0YA5

Basic configuration for individual product packages

SIMATIC PDM Basic V6.1
Product package for operator input and configuration of field devices and components, communication via PROFIBUS DP/PA, HART (modem, RS 232, PROFIBUS), SIREC bus, SIPART DR, Modbus or Ethernet, including 4 TAGs

6 languages (German, English, French, Italian, Spanish, Chinese), software class A, runs with Windows XP Professional/ Server 2003, floating license for 1 user

Delivery package: License key memory stick, Certificate of License including Terms and Conditions; software SIMATIC PDM V6.1 and device library on CD/DVD

6ES7 658-3AX16-0YA5

Application-specific configurations

SIMATIC PDM Service V6.1

Product package for stand-alone users for servicing, with

- SIMATIC PDM Basic V6.1
- 128 TAGs

6 languages (German, English, French, Italian, Spanish, Chinese), software class A, runs with Windows XP Professional/ Server 2003, floating license for 1 user

Delivery package: License key memory stick, Certificate of License including Terms and Conditions; software SIMATIC PDM V6.1 and device library on CD/DVD

6ES7 658-3JX16-0YA5

SIMATIC PDM S7 V6.1

Product package for use in a SIMATIC S7 configuration environment, with

- SIMATIC PDM Basic V6.1
- Integration in STEP 7 / PCS 7
- 128 TAGs

6 languages (German, English, French, Italian, Spanish, Chinese), software class A, runs with Windows XP Professional/ Server 2003, floating license for 1 user

Delivery package: License key memory stick, Certificate of License including Terms and Conditions; software SIMATIC PDM V6.1 and device library on CD/DVD

6ES7 658-3KX16-0YA5

Software for SIMATIC controllers

Software for joint tasks in the maintenance sector

SIMATIC PDM

Ordering data	Order No.	Order No.	
Optional product components for SIMATIC PDM V6.1 Integration in STEP 7 / SIMATIC PCS 7 only required for integration of SIMATIC PDM into HW Config 6 languages (German, English, French, Italian, Spanish, Chinese), software class A, runs with Windows XP Professional/ Server 2003, floating license for 1 user Delivery package: License key memory stick, Certificate of License including Terms and Conditions	6ES7 658-3BX16-2YB5	Demonstration software SIMATIC PDM Demo V6.1 Without online communication and storage functionality 6 languages (German, English, French, Italian, Spanish, Chinese), software class A, runs with Windows XP Professional/ Server 2003 Delivery package: SIMATIC PDM V6.1 software and device library on CD/DVD	6ES7 658-3GX16-0YC8
Routing 6 languages (German, English, French, Italian, Spanish, Chinese), software class A, runs with Windows XP Professional/ Server 2003, floating license for 1 user Delivery package: License key memory stick, Certificate of License including Terms and Conditions	6ES7 658-3CX16-2YB5	Product packages SIMATIC PDM S7 V8.0 Product package for use in a SIMATIC S7 configuration environment, with <ul style="list-style-type: none"> • SIMATIC PDM Basic and Extended • Integration in STEP 7 / PCS 7 • 100 TAGs 5 languages (German, English, French, Italian, Spanish), software class A, runs with Windows XP Professional 32-bit, Windows 7 Ultimate 32/64-bit, Windows Server 2003 R2 Standard 32-bit or Windows Server 2008 R2 Standard 64-bit, floating license for 1 user Note: SIMATIC PDM S7 V8.0 requires the installation of STEP 7 V5.5+SP2. Delivery package: License key memory stick, certificate of license; SIMATIC PDM V8.0 software and device library on DVD	6ES7 658-3KX08-0YA5
Communication via standard HART multiplexer 6 languages (German, English, French, Italian, Spanish, Chinese), software class A, runs with Windows XP Professional/ Server 2003, floating license for 1 user Delivery package: License key memory stick, Certificate of License including Terms and Conditions	6ES7 658-3EX16-2YB5	Optional product components Routing V8.0 5 languages (German, English, French, Italian, Spanish), software class A, runs with Windows XP Professional 32-bit, Windows 7 Ultimate 32/64-bit, Windows Server 2003 R2 Standard 32-bit or Windows Server 2008 R2 Standard 64-bit, floating license for 1 user Delivery package: License key memory stick, certificate of license	6ES7 658-3CX08-2YB5
TAG options/PowerPacks for SIMATIC PDM V6.1 SIMATIC PDM TAG option for TAG expansion, additive to SIMATIC PDM Basic V6.1 Software class A, runs with Windows XP Professional/Server 2003, floating license for 1 user Delivery package: License key memory stick, Certificate of License including Terms and Conditions <ul style="list-style-type: none"> • Up to 128 TAGs • Up to 512 TAGs • Up to 1 024 TAGs • Up to 2 048 TAGs 	6ES7 658-3XA16-2YB5 6ES7 658-3XB16-2YB5 6ES7 658-3XC16-2YB5 6ES7 658-3XD16-2YB5	SIMATIC PDM Communication FOUNDATION Fieldbus V8.0 5 languages (German, English, French, Italian, Spanish), software class A, runs with Windows XP Professional 32-bit, Windows 7 Ultimate 32/64-bit, Windows Server 2003 R2 Standard 32-bit or Windows Server 2008 R2 Standard 64-bit, floating license for 1 user Delivery package: License key memory stick, certificate of license	6ES7 658-3QX08-2YB5
SIMATIC PDM PowerPack for TAG expansion, for any SIMATIC PDM V6.1 product packages Software class A, runs with Windows XP Professional/ Server 2003, floating license for 1 user Delivery package: License key memory stick, Certificate of License including Terms and Conditions <ul style="list-style-type: none"> • From 128 TAGs to 512 TAGs • From 512 TAGs to 1 024 TAGs • From 1 024 TAGs to 2 048 TAGs • From 2 048 TAGs to unlimited number of TAGs 	6ES7 658-3XB16-2YD5 6ES7 658-3XC16-2YD5 6ES7 658-3XD16-2YD5 6ES7 658-3XH16-2YD5		

Software for SIMATIC controllers

Software for joint tasks in the maintenance sector

SIMATIC PDM

Ordering data	Order No.	Ordering data	Order No.
<p>SIMATIC PDM TAGs for SIMATIC PDM V8.0</p> <p>SIMATIC PDM TAGs TAG licenses for expanding SIMATIC PDM product packages V7.0 or higher, can be accumulated, software class A, floating license for 1 user</p> <p>Delivery package: License key memory stick, certificate of license</p> <ul style="list-style-type: none"> • 10 TAGs • 100 TAGs • 1 000 TAGs 	<p>6ES7 658-3XC00-2YB5 6ES7 658-3XD00-2YB5 6ES7 658-3XE00-2YB5</p>	<p>Demonstration software</p> <p>SIMATIC PDM Demo V8.0 Without online communication and storage functionality</p> <p>6 languages (German, English, French, Italian, Spanish, Chinese), software class A, runs with Windows XP Professional 32-bit, Windows 7 Ultimate 32/64-bit, Windows Server 2003 R2 Standard 32-bit or Windows Server 2008 R2 Standard 64-bit</p> <p>Delivery package: SIMATIC PDM V8.0 software and device library on DVD</p>	<p>6ES7 658-3GX08-0YT8</p>

Software for SIMATIC controllers

Software for joint tasks in the administration sector

Version cross manager

Overview

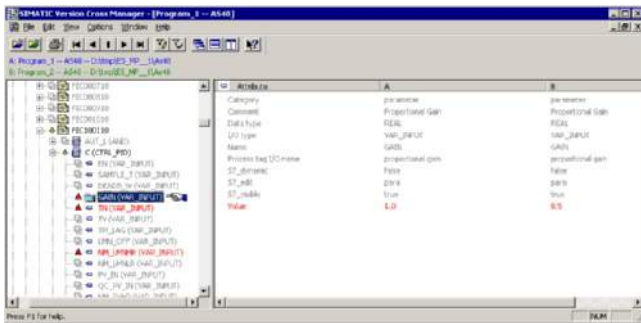

The SIMATIC Version Cross Manager is a user-friendly tool for determining the differences between various versions of individual projects or multi-projects by:

- tracing missing, additional or differing objects by comparing hardware configuration, communication, plant hierarchy, CFC/SFC plans, SFC details, block types, messages, global tags, signals and run sequences
- Graphic display of comparison results in a combination of tree and tabular formats
- Clear hierarchical structuring according to the technological hierarchy of the plant
- Color-coded identification of the differences

Ordering data

Order No.

SIMATIC Version Cross Manager V7.1

Can be used with SIMATIC PCS 7 V7.1 and V8.0
6 languages (English, German, French, Italian, Spanish, Chinese), software class A, runs with Windows XP Professional 32-bit, Windows 7 Ultimate 32/64-bit, Windows Server 2003 R2 Standard 32-bit or Windows Server 2008 R2 Standard 64-bit, floating license for 1 user

- Delivery package (without SIMATIC PCS 7 Software Media Package) License key on USB stick, Certificate of License as well as TIA Engineering Toolset CD

6ES7 658-1CX17-2YA5

- Delivery package (without SIMATIC PCS 7 Software Media Package) License key download, Certificate of License online
Note:
E-mail address required!

6ES7 658-1CX17-2YH5

Software for SIMATIC controllers

Software for joint tasks in the administration sector

Version Trail

Overview

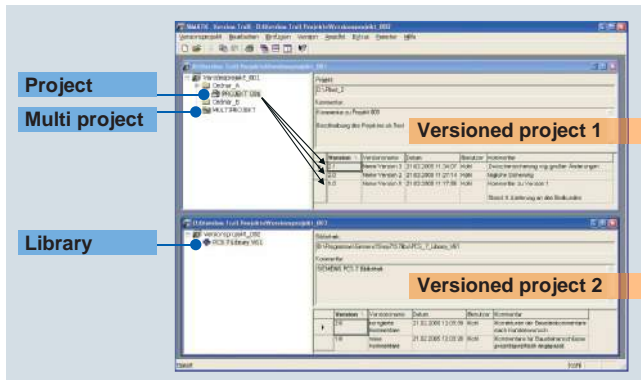

SIMATIC Version Trail is a software option for engineering which, together with the SIMATIC Logon central user administration, can assign a version history to libraries, projects and multi-projects.

Ordering data

Order No.

SIMATIC Version Trail V8.0

6 languages (English, German, French, Italian, Spanish, Chinese), software class A, runs with Windows XP Professional 32-bit, Windows 7 Ultimate 32/64-bit, Windows Server 2003 R2 Standard 32-bit, or Windows Server 2008 R2 Standard 64-bit, floating license for 1 user

- Delivery package (without SIMATIC PCS 7 Software Media Package)
License key on USB stick, Certificate of License as well as TIA Engineering Toolset CD

6ES7 658-1FX08-2YA5

- Delivery package (without SIMATIC PCS 7 Software Media Package) License key download, Certificate of License online

6ES7 658-1FX08-2YH5

Note:
E-mail address required!

Software for SIMATIC controllers

Software for joint tasks in the administration sector

ADDM - Data Management

Overview



With ADDM, you are completely in control of the SIMATIC and SINUMERIK controls – around the clock and with any program version. This tool is indispensable in a modern production area and ensures user-friendly backup, comparison and management of control data.

Ordering data

Order No.

ADDM

Software package
Languages: English, German

ADDM Single User

- For PC/PG with Windows XP
- Single license with CD-ROM of current software version
 - Single user upgrade

6BQ3 030-1AA30-3AD0

6BQ3 030-1AB13-3AD0

ADDM Client

- For PC/PG with Windows XP
- Single license with CD-ROM of current software version
 - Client upgrade from V5.x to V6.2 with CD-ROM

6BQ3 030-1AA10-0AD0

6BQ3 030-1AB11-3AD0

ADDM Server

For server PC with Windows XP and Windows 2003 Server

- Single license with CD-ROM of current software version
- Server upgrade from V5.x to V6.2 with CD-ROM

6BQ3 030-1AA00-3AD0

6BQ3 030-1AB10-3AD0

ADDM Agent

For SINUMERIK PCU with HMI-Advanced

- Single license without data carrier
- Single license with CD-ROM of current software version
- Agent upgrade from V1.x to V1.3 with CD-ROM

6BQ3 030-1AA00-1AB0

6BQ3 030-4AA00-0AD0

6BQ3 030-1AB12-3AD0

Software for SIMATIC controllers

Additional software

KNX/EIB2S7

Overview



- Software for SIMATIC S7 communication with components of a building automation unit
- For use of industry automation components in building automation
- Allows the integration of actuators/sensors on a KNX/EIB bus in automation solutions with SIMATIC S7
- For the use of information from building automation for the automation of a production plant

Ordering data

Order No.

KNX/EIB2S7 program package

6AV6 643-7AC10-0AA1

Task:

Software for connecting KNX/EIB building technology components to SIMATIC S7;

Type of delivery:

Editor, function blocks for SIMATIC S7, samples, documentation on CD; license for editor on USB flash memory

SIMATIC programming devices

**12/2 Programming devices**

12/2 Field PG M4

12/6 Accessories

12/6 External prommer

12/7 Communications software

12/7 SOFTNET for PROFIBUS

12/9 HARDNET-IE S7-REDCONNECT

12/11 SOFTNET for Industrial Ethernet

12/13 SOFTNET PN IO

12/15 OPC server for Industrial Ethernet

12/17 PN CBA OPC server

12/19 SNMP OPC server

Brochures

For brochures serving as selection guides for SIMATIC products refer to:

www.siemens.com/simatic/printmaterial

SIMATIC programming devices

Programming devices

Field PG M4

Overview



- The mobile, industry-standard programming device with a powerful, third-generation Intel® Core™ i processor
- Optimal for commissioning, service and maintenance of automation systems.
- Industrial notebook with wireless technology, large 15.6" widescreen display, long battery life, high-speed RAM, and integral data backup concept.
- Complete with all commonly used interfaces for industrial applications.

Technical specifications

SIMATIC Field PG M4	
General features	
Design	Notebook
Processor	<ul style="list-style-type: none"> • Intel Celeron 1020E processor, 2.2 GHz, 2 MB cache • Intel Core i5-3320M processor, up to 3.3 GHz, 3 MB cache • Intel Core i7-3520M processor, up to 3.6 GHz, 4 MB cache
RAM	Expandable up to 16 GB DDR3 SODIMM
Free slots for expansions	<ul style="list-style-type: none"> • 1 x PC Card (Type I, Type II) • 1 x Express Card (34 and 54 mm)
Graphics	Intel HD4000 graphics with a resolution of 2560 x 1600 pixels for i5 and i7 processors
Display	15.6" widescreen display, 16:9 format <ul style="list-style-type: none"> • 1366 x 768 (HD ready) • 1920 x 1080 (full HD)
Speakers	Built-in stereo speakers
Pointing device	Touchpad with 2 mouse buttons
Operating system	Windows XP Prof. SP3 Engl. MUI, 32-bit (Eng., Fr., Ger., Sp., It.; additional languages can be installed later) Windows 7 Ultimate SP 1, 64-bit (Eng., Fr., Ger., Sp., It.; additional languages can be installed later)
Power supply	Wide-range power supply unit 100-240 V AC, 50-60 Hz, high-power 8800 mAh lithium-ion battery (running time of more than 5 hours; discharge time of more than 5 months when not in use)
Warranty conditions	24 months for hardware components (6 months for battery ¹⁾)

SIMATIC Field PG M4	
Drives	
Hard disk	Easily swappable hard drive (250 or 500 GB HDD) or super-fast solid-state drive (300 GB SSD)
Optical drive	Multistandard DVD+-R/+-RW
Interfaces	
PROFIBUS DP/MPI	CP 5711-compatible, 9.6 Kbit/s to 12 Mbit/s, 9-pin sub D socket; can also be used in virtual operating systems
COM 1	V.24/TTY (for SIMATIC S5; TTY as optional version); over supplied adapter on 9-pin sub-D male connector
SIMATIC Memory Card	Programming interface for SIMATIC Memory Card and S5 memory module (S5 EPROM module as optional equipment variant)
SIMATIC Micro Memory Card	Interface for SIMATIC Micro Memory Card
Media Card Reader	Interface for SMC (SIMATIC Memory Card) SD/SHC xD-Picture Card MS Pro
Ethernet	2 x Gigabit Ethernet (RJ45)
USB	2 x USB 3.0, max. 1 high current (900 mA); under Windows XP as USB 2.0 2 x USB 2.0, for High Speed USB; max. 2 High Current (500 mA) or 1 A; of which 1 USB interface with charging function for mobile devices in power off mode

¹⁾ The capacity of the battery decreases for technological reasons with each charging/discharging operation and also as the result of being stored at excessively high or low temperatures. The running time per charge decreases therefore over the course of time. With normal use, the battery can be charged and discharged over a period of six months from when the Field PG is purchased. Capacity loss is not covered by the warranty. For the battery's operation we grant a warranty of six months. We recommend replacing the battery with an original Siemens battery at the end of these six months if there is a significant drop in performance.

Technical specifications (continued)

	SIMATIC Field PG M4
Interfaces (continued)	
PC Card (PCMCIA)/Express Card/54	<ul style="list-style-type: none"> • 1 x PC Card (Type I, Type II) • 1 x Express Card (34 and 54 mm)
DVI-I	1 interface for external monitor (VGA monitors can be operated with a DVI/VGA adapter)
DPP (Display Port)	Interface for external monitor, max. resolution: 2560 x 1600 pixels
WLAN ²⁾	Integrated, IEEE802.11 a, b, g, n
Headphones/microphone	Connection in each case for 3.5 mm stereo jack
Ambient conditions	
Degree of protection in accordance with IEC 60529	Front IP30 when covers closed
Vibrations	Tested in accordance with DIN IEC 60068-2-6
• Operation	10 to 58 Hz: Amplitude 0.0375 mm, 58 to 500 Hz: Acceleration 4.9 m/s ²
• Transport	5 to 9 Hz: Amplitude 3.5 mm; 9 to 500 Hz: Acceleration 9.8 m/s ²
Resistance to shock	Tested in accordance with IEC 60068-2-27, IEC 60068-2-29
• Operation	Half-sine 50 m/s ² , 30 ms, 100 shocks
• Storage/transport	Half-sine 250 m/s ² , 6 ms, 1000 shocks
Electromagnetic compatibility (EMC)	
• Radiated interference	EN 61000-6-3:2007, EN 61000-3-2 Class D and EN 61000-3-3
• Immunity to conducted interference on the supply lines	± 2 kV; (according to IEC 61000-4-4; burst) ± 1 kV; (according to IEC 61000-4-5; surge sym./line to line) ± 2 kV; (according to IEC 61000-4-5; surge sym./line to ground)
• Noise immunity on signal lines	± 1 kV; (according to IEC 61000-4-4; burst; length < 30 m) ± 2 kV; (according to IEC 61000-4-4; burst; length > 30 m) ± 2 kV; (according to IEC 61000-4-5; surge sym./line to ground; length > 30 m)
• Immunity to static discharge	± 4 kV discharge on contact (in accordance with IEC 61000-4-2: ESD) ± 8 kV discharge to air (in accordance with IEC 61000-4-2: ESD)
• Immunity to high frequency radio interference	10 V (with modem operation max. 3 V), with 80% amplitude modulation with 1 kHz, 10 kHz ... 80 MHz (in accordance with IEC 61000-4-6) 10 V/m (with modem operation max. 3 V/m), with 80% amplitude modulation with 1 kHz, 80 MHz ... 1000 MHz and 1.4 GHz ... 2 GHz (in accordance with IEC 61000-4-3) 1 V/m, with 80% amplitude modulation with 1 kHz, 2.0 GHz ... 2.7 GHz 1 V/m (in accordance with IEC 61000-4-3)
• Immunity to magnetic fields	100 A/m; 50/60 Hz (in accordance with IEC 61000-4-8)

	SIMATIC Field PG M4
Temperature	Tested in accordance with IEC 60068-2-1, IEC 60068-2-2 + 5 °C ... + 40 °C max. 10°C/h (no condensation)
• Operation ³⁾	
• Storage/transport	- 20 °C ... + 60 °C max. 20°C/h (no condensation)
Relative humidity	Tested according to IEC 60068-2-78, IEC 60068-2-30, IEC 60068-2-14
• Operation	5 % ... 80% at 25°C/h (no condensation)
• Storage/transport	5 % ... 95% at 25°C/h (no condensation)
Safety	
Safety class	Safety class II according to IEC 61140
Safety regulations	<ul style="list-style-type: none"> • According to VDE 0805 in conformance with IEC 60950-1:2006 • IEC 60950-1:2005 • EN 60950-1:2006 with change EN 60950-1:2006/A11:2009 • DIN EN 60950-1 (VDE0805-1):2006-11 with change DIN EN 60950-1/A11 (VDE0805-1/A11):2009-11 • UL 60950-1 Second Edition • CAN/CSA-C22.2 No. 60950-1-07 Second Edition
Dimensions and weights	
Dimensions (W x H x D) in mm	385 x 53 x 275
Weight, approx.	Without battery approx. 3 kg With battery approx. 3.4 kg

²⁾ Integral WLAN with antennas specially designed for the Field PG M4. The integral wireless LAN is approved for operation in Europe (CE), the USA (FCC) and Canada (IC), and is under application in Korea (KCC) and China (CCC).

For operation outside these countries, the relevant national regulations must be observed.

³⁾ Battery charging and CD/DVD writing is only possible at temperatures up to 35 °C

SIMATIC programming devices

Programming devices

Field PG M4

Ordering data

Order No.

Ordering data	Order No.
SIMATIC Field PG M4 Standard programming device Intel Celeron 1020E processor, 2 MB cache, 2.2 GHz, 250 GB HDD SATA hard disk, multistandard DVD+-R/+RW drive, Intel HD graphics; without SIMATIC S5 interface, without SIMATIC S5 EPROMMER	6ES7 716- 0 A A -0 1
Display <ul style="list-style-type: none"> 15.6" display, HD ready (1366 x 768) 0 15.6" display, full HD (1920 x 1080) 1 	
Keyboard and power cable (essential) <ul style="list-style-type: none"> Keyboard: QWERTY (& German); power supply cord: Germany, France, the Netherlands, Spain, Belgium, Austria, Sweden, Finland 0 Keyboard: QWERTY (& German); power supply cord: United Kingdom 1 Keyboard: QWERTY (& German); power supply cord: Switzerland 2 Keyboard: QWERTY (& German); power supply cord: USA 3 Keyboard: QWERTY (& German); power supply cord: Italy 4 Keyboard: AZERTY; power supply cord: Germany, France, The Netherlands, Spain, Belgium, Austria, Sweden, Finland 6 Keyboard: AZERTY; power supply cord: Switzerland 7 	
Operating system <ul style="list-style-type: none"> Windows 7 Ultimate, SP1, 64-bit (Eng., Fr., Ger., Sp., It., selectable); STEP 5 and STEP 7 Micro/Win not pre-installed. STEP 5 cannot run on Windows 7; installed main memory: 1 x 8 GB DDR3 RAM B Windows 7 Ultimate, SP1, 64-bit (Eng., Fr., Ger., Sp., It., selectable); STEP 5 and STEP 7 Micro/Win not pre-installed. STEP 5 cannot run on Windows 7; installed main memory: 2 x 8 GB DDR3 RAM C 	
SIMATIC software licenses <ul style="list-style-type: none"> Trial license: STEP 7 Prof. Combo (STEP 7 Prof. V12 and STEP 7 Prof. 2010), WinCC Adv. Combo (WinCC V12 and WinCC flexible 2008), STEP 7 Micro/Win V4.1 MPI cable not included A License: STEP 7 Prof. Combo (STEP 7 Prof. V12 and STEP 7 Prof. 2010), WinCC Adv. Combo (WinCC V12 and WinCC flexible 2008), STEP 7 Micro/Win V4.1 incl. MPI cable B 	

Order No.

Ordering data	Order No.
Programming device Field PG M4 Premium and Premium Plus Field PG M4 Premium: Intel Core i5 3320M processor, 3 MB cache, 2.6 GHz (max. 3.3 GHz with turbo boost technology), multistandard DVD+-R/+RW drive, Intel HD4000 graphics card Field PG M4 Premium Plus: Intel Core i7 3520M processor, 4 MB cache, 2.9 GHz (max. 3.6 GHz with turbo boost technology), multistandard DVD+-R/+RW drive, Intel HD4000 graphics card	6ES7 716- 1 2 -0 1
Hard disk <ul style="list-style-type: none"> 500 GB HDD SATA (for Field PG M4 Premium and Premium Plus) B 300 GB SSD SATA (for Field PG M4 Premium and Premium Plus) C 	
SIMATIC S5 interface <ul style="list-style-type: none"> Without S5 interface, without S5 EPROMMER A With S5 interface, with S5 EPROMMER incl. S5 PLC cable and EPROM adapter B 	
Display <ul style="list-style-type: none"> 15.6" display, HD ready (1366 x 768) 0 15.6" display, full HD (1920 x 1080) 1 	
Keyboard and power cable (essential) <ul style="list-style-type: none"> Keyboard: QWERTY (& German); power supply cord: Germany, France, The Netherlands, Spain, Belgium, Austria, Sweden, Finland 0 Keyboard: QWERTY (& German); power supply cord: United Kingdom 1 Keyboard: QWERTY (& German); power supply cord: Switzerland 2 Keyboard: QWERTY (& German); power supply cord: USA 3 Keyboard: QWERTY (& German); power supply cord: Italy 4 Keyboard: AZERTY; power supply cord: Germany, France, The Netherlands, Spain, Belgium, Austria, Sweden, Finland 6 Keyboard: AZERTY; power supply cord: Switzerland 7 	

Ordering data	Order No.	Order No.
Programming device Field PG M4 Premium and Premium Plus Operating system <ul style="list-style-type: none"> Windows XP Professional SP3 32-bit MUI (Eng., Ger., Fr., It., Sp.); installed RAM: 1 x 4 GB DDR3 RAM STEP 7 Professional V12 and WinCC Advanced V12 not pre-installed. Windows 7 Ultimate, SP1, 64-bit (Eng., Fr., Ger., Sp., It., selectable); STEP 5 and STEP 7 Micro/Win not pre-installed. STEP 5 cannot run on Windows 7; installed main memory: 1 x 8 GB DDR3 RAM Windows 7 Ultimate, SP1, 64-bit (Eng., Fr., Ger., Sp., It., selectable); STEP 5 and STEP 7 Micro/Win not pre-installed. STEP 5 cannot run on Windows 7; installed main memory: 2 x 8 GB DDR3 RAM 	6ES7 716- ■ ■ ■ ■ ■ -0 ■ ■ 1	
	A	
	B	
	C	
SIMATIC software licenses <ul style="list-style-type: none"> Trial license: STEP 7 Prof. Combo (STEP 7 Prof. V12 and STEP 7 Prof. 2010), WinCC Adv. Combo (WinCC V12 and WinCC flexible 2008), STEP 7 Micro/Win V4.1 MPI cable not included License: STEP 7 Prof. Combo (STEP 7 Prof. V12 and STEP 7 Prof. 2010), WinCC Adv. Combo (WinCC V12 and WinCC flexible 2008), STEP 7 Micro/Win V4.1 incl. MPI cable License: STEP 7 Prof. Combo (STEP 7 Prof. V12 and STEP 7 Prof. 2010), WinCC Adv. Combo (WinCC V12 and WinCC flexible 2008), STEP 7 Micro/Win V4.1, STEP 5; incl. MPI cable 		A
		B
		C
Accessories		
Memory expansion		
4 GB RAM	6ES7 648-2AH60-0KA0	
8 GB RAM	6ES7 648-2AH70-0KA0	
AC/DC external power supply unit	6ES7798-0GA03-0XA0	
For Field PG M4 only		
Power cord (length 3 m)		
For Field PG M2/M4 only		
For Germany, France, The Netherlands, Spain, Belgium, Austria, Sweden, Finland	6ES7 900-5AA00-0XA0	
For Great Britain	6ES7 900-5BA00-0XA0	
For Switzerland	6ES7 900-5CA00-0XA0	
For the USA	6ES7 900-5DA00-0XA0	
For Italy	6ES7 900-5EA00-0XA0	
		Spare battery (lithium ion, 8.8 Ah)¹⁾ For Field PG M4 only 6ES7 798-0AA07-0XA0
		MPI cable For connecting a PG and SIMATIC S7 via MPI; 5 m 6ES7 901-0BF00-0AA0
		S5 EPROM programming adapter For SIMATIC S5 EPROM programming using the Field PG 6ES7 798-0CA00-0XA0
		S5 PLC cable For connecting programming devices to SIMATIC S5 PLCs, 5 m 6ES5 734-2BF00
		Replaceable hard disk kit Replaceable hard disk 500 GB serial ATA; with protective pocket and Torx screwdriver; for Field PG M3/M4 only 6ES7 791-2BA01-0AA0
		Replaceable SSD kit Replaceable SSD 300 GB serial ATA; with protective pocket and Torx screwdriver; for Field PG M3/M4 only 6ES7 791-2BA20-0AA0
		Adapter serial ATA to USB 2.0 For using the replaceable hard disk contained in the hard disk kit as an external hard disk (for Field PG M/M2/M3/M4 only) 6ES7 790-1AA00-0AA0
		Adapter serial ATA to USB 3.0 For using the removable hard disk in the hard disk kit as an external hard disk (only for Field PG M4) 6ES7 790-1AA01-0AA0
		Backpack for Field PG M4 6ES7 798-0DA02-0XA0
		SIMATIC IPC Image & Partition Creator V3.3 Software tool for very easy preventive data backup and efficient partition management on SIMATIC IPCs 6ES7 648-6AA03-3YA0
		Software Update Service (Standard Edition)²⁾ The delivery is implemented according to the number of ordered SUS products (e.g. 10 upgrade packages with 10 DVDs, 10 USB flash drives, etc.) <ul style="list-style-type: none"> STEP 7 Professional and STEP 7 Professional in the TIA Portal WinCC Advanced 6ES7 810-5CC04-0YE2 6AV6 613-0AA00-0AL0

¹⁾ The capacity of the battery decreases for technological reasons with each charging/discharging operation and also as the result of being stored at excessively high or low temperatures. The running time per charge decreases therefore over the course of time. With normal use, the battery can be charged and discharged over a period of six months from when the Field PG is purchased. Capacity loss is not covered by the warranty. For the battery's operation we grant a warranty of six months. We recommend replacing the battery with an original Siemens battery at the end of these six months if there is a significant drop in performance.

²⁾ For more information on the Software Update Service, see chapter 11, page 11/3.

SIMATIC programming devices

Accessories

External prommer

Overview

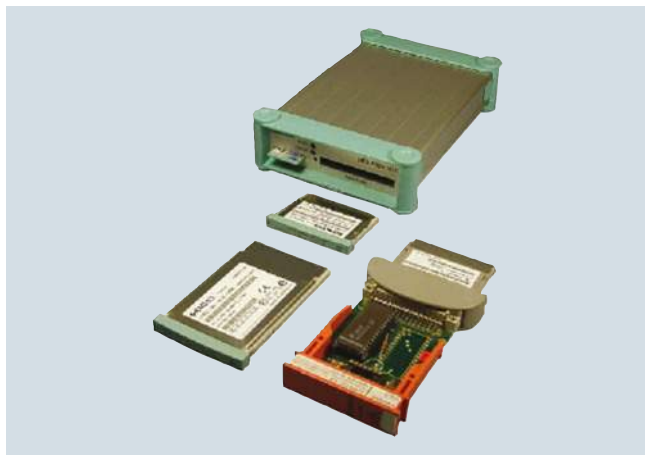

- External EPROM programming device
- For programming SIMATIC memory cards, SIMATIC micro memory cards as well as SIMATIC EPROM and EEPROM modules
- For connection to the PC via the USB interface

Technical specifications

6ES7 792-0AA00-0XA0	
Display	
Design of display	without
Ambient conditions	
Operating temperature	
• Min.	5 °C
• max.	40 °C
Storage/transport temperature	
• Min.	-20 °C
• max.	60 °C
Dimensions	
Width	172 mm
Height	40 mm
Depth	121 mm
Weight	
Weight, approx.	400 g

Ordering data

**EPROM programming device
USB-Prommer**
for programming SIMATIC memory
cards and EPROM modules

Order No.

6ES7 792-0AA00-0XA0

Overview

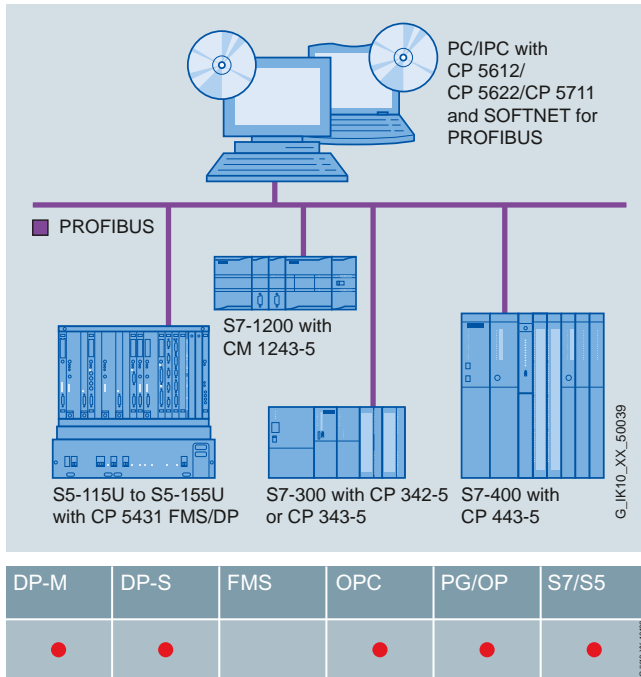

Technical specifications

Performance data	CP 5512/CP 5611 A2/CP 5612/CP 5621/CP 5622/CP 5711
<u>Mono protocol mode</u>	
Number of connectable DP slaves	max. 60
Number of FDL tasks waiting	max. 50
Number of PG/OP and S7 connections	max. 8
• DP master	DP-V0, DP-V1 with SOFTNET-PB DP
• DP slave	DP-V0, DP-V1 with SOFTNET-PB DP slave

- Software for connecting PCs/programming devices and notebooks to programmable controllers
- Communication services:
 - PROFIBUS DP master Class 1 and 2 with acyclic expansions
 - PROFIBUS DP slave
 - PG/OP communication
 - S7 communication
 - Open communication (SEND/RECEIVE) based on the FDL interface
- The corresponding OPC servers are included in the scope of supply of the respective communication software
- Can be used with:
 - CP 5512 (PC card, CardBus 32-bit)
 - CP 5611 A2 and CP 5612 (PCI, 32-bit)
 - CP 5612 (PCI, 32-bit)
 - CP 5621 and CP 5622 (PCIe x1)
 - CP 5622 (PCIe x1)
 - CP 5711 (USB V2.0)
 - Integrated PROFIBUS interfaces of SIMATIC PGs/PCs

SIMATIC programming devices

Communications software

SOFTNET for PROFIBUS

Ordering data	Order No.	Order No.
SOFTNET-PB S7 Software for S7 communication, incl. FDL protocol with OPC server and NCM PC, runtime software, software and electronic manual on CD-ROM, license key on USB flash drive, Class A; for CP 5611 A2, CP 5612 (Win 7 and higher), CP 5621, CP 5622 (Win 7 and higher), CP 5711;		SOFTNET-DP Edition 2008 (V7.1) for Windows XP Professional SP2/3; Windows 2003 Server R2, SP2; Windows Vista Business/Ultimate SP1; Windows 2008 Server; English/German • Single License for one installation 6GK1 704-5DW71-3AA0
SOFTNET-PB S7 V8.2 for 32/64-bit: Windows 7 Professional/Ultimate; for 64-bit: Windows 2008 Server R2 German/English • Single License for one installation	6GK1 704-5CW08-2AA0	Software Update Service For 1 year with automatic extension; requirement: current software version 6GK1 704-5DW00-3AL0
SOFTNET-S7 Edition 2008 (V7.1) for 32 Bit Windows XP Professional SP2/3; Windows 2003 Server R2, SP2; Windows Vista Business/Ultimate SP1; Windows 2008 Server; English/German • Single License for one installation	6GK1 704-5CW71-3AA0	Upgrade • From Edition 2006 to SOFTNET-DP Edition 2008 or V8.1 • From V6.0, V6.1, V6.2 or V6.3 to SOFTNET-DP Edition 2008 or V8.1 6GK1 704-5DW00-3AE0 6GK1 704-5DW00-3AE1
Software Update Service For 1 year with automatic extension; requirement: current software version	6GK1 704-5CW00-3AL0	SOFTNET-PB DP slave Software for DP slave, with DP OPC server and NCM PC, single license for one installation, runtime software, software and electronic manual on CD-ROM, license key on USB flash drive, Class A; for CP 5611 A2, CP 5612 (Win 7 and higher), CP 5621, CP 5622 (Win 7 and higher), CP 5711;
Upgrade • From Edition 2006 to SOFTNET-S7 Edition 2008 or V8.1 • From V6.0, V6.1, V6.2 or V6.3 to SOFTNET-S7 Edition 2008 or V8.1	6GK1 704-5CW00-3AE0 6GK1 704-5CW00-3AE1	SOFTNET-PB DP Slave V8.2 for 32/64-bit: Windows 7 Professional/Ultimate; for 64-bit: Windows 2008 Server R2 German/English • Single License for one installation 6GK1 704-5SW08-2AA0
SOFTNET-PB DP Software for DP protocol (master class 1 and 2), incl. FDL protocol with OPC server and NCM PC, runtime software, software and electronic manual on CD-ROM, license key on USB flash drive; for CP 5611 A2, CP 5612 (Win 7 and higher), CP 5621, CP 5622 (Win 7 and higher), CP 5711;		SOFTNET-DP Slave Edition 2008 (V7.1) for 32 Bit Windows XP Professional SP2/3; Windows 2003 Server R2, SP2; Windows Vista Business/Ultimate SP1; Windows 2008 Server; English/German • Single License for one installation 6GK1 704-5SW71-3AA0
SOFTNET-PB DP V8.2 for 32/64-bit: Windows 7 Professional/Ultimate; for 64-bit: Windows 2008 Server R2 German/English • Single License for one installation	6GK1 704-5DW08-2AA0	Software Update Service For 1 year with automatic extension; requirement: current software version 6GK1 704-5SW00-3AL0
		Upgrade • From Edition 2006 to SOFTNET-DP Slave Edition 2008 or V8.1 • From V6.0, V6.1, V6.2 or V6.3 to SOFTNET-DP Slave Edition 2008 or V8.1 6GK1 704-5SW00-3AE0 6GK1 704-5SW00-3AE1

Overview

- For connecting PCs over redundant Industrial Ethernet to the SIMATIC S7-400H
- Protected from communication failures arising from a fault in the double bus or in redundant rings
- For redundant Layer 2 or Layer 3 Industrial Ethernet
- Can also be implemented in non-redundant networks
- No additional programming overhead for the PC and in H systems
- The appropriate OPC server and configuration tools are included in the scope of supply of the respective communication software
- Enhanced redundancy over 4-way communication (STEP 7 V5.1 + SP4 and higher)

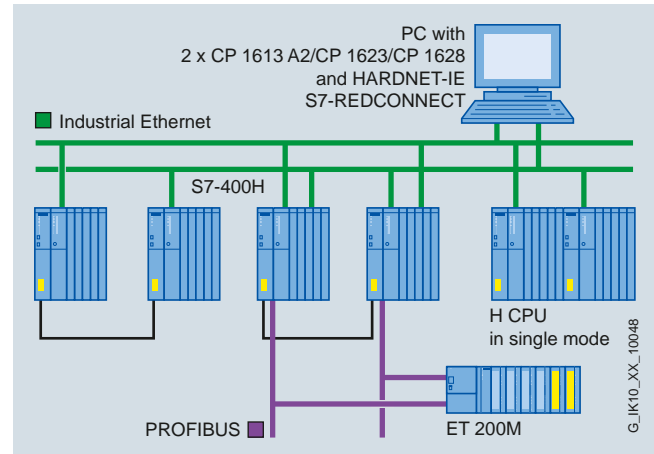

System configuration for S7-REDCONNECT

ISO	TCP/ UDP	PN	MRP	OPC	PG/OP	S7/S5	IT
●				●	●	●	

G_KDXX_0106

SIMATIC programming devices

Communications software

HARDNET-IE S7-REDCONNECT

Ordering data	Order No.	Ordering data	Order No.
HARDNET-IE S7-REDCONNECT Software for fail-safe S7 communication via redundant networks, incl. S7 OPC server, HARDNET-IE S7, runtime software, software and electronic manual on CD-ROM, license key on USB stick, Class A;		HARDNET-IE S7-REDCONNECT Power Pack For expansion from HARDNET-IE S7 to S7-REDCONNECT, single license for one installation, runtime software, software and electronic manual on CD-ROM, license key on USB stick, Class A;	
HARDNET-IE S7-REDCONNECT V8.2 for 32/64-bit: Windows 7 Professional/Ultimate; for 64-bit: Windows 2008 Server R2 German/English • Single License for one installation	6GK1 716-0HB08-2AA0	HARDNET-IE S7-REDCONNECT Power Pack V8.2 for 32/64-bit: Windows 7 Professional/Ultimate; for 64-bit: Windows 2008 Server R2; German/English;	6GK1 716-0HB08-2AC0
S7-REDCONNECT Edition 2008 (V7.1) for 32 Bit Windows XP Professional SP 2/3; Windows 2003 Server R2, SP2; Windows Vista Business/Ultimate SP1; Windows 2008 Server; English/German • Single License for one installation	6GK1 716-0HB71-3AA0	S7-REDCONNECT Power Pack Edition 2008 (V7.1) for 32 Bit Windows XP Professional SP 2/3; Windows 2003 Server R2, SP2; Windows Vista Business/Ultimate SP1; Windows 2008 Server; English/German	6GK1 716-0HB71-3AC0
Software Update Service For 1 year with automatic extension; requirement: current software version	6GK1 716-0HB00-3AL0	CP 1613 A2 communications processor PCI card (32-bit, 33 MHz/66 MHz; 3.3 V/5 V universal keyed) for connection to Industrial Ethernet (10/100 Mbit/s) with ITP and RJ45 connection over HARDNET-IE S7 and S7-REDCONNECT, for operating system support see SIMATIC NET Software	6GK1 161-3AA01
Upgrade • From Edition 2006 to S7-REDCONNECT Edition 2008 or V8.1 • From V6.0, V6.1, V6.2 or V6.3 to S7-REDCONNECT Edition 2008 or V8.1	6GK1 716-0HB00-3AE0 6GK1 716-0HB00-3AE1	CP 1623 communications processor PCI Express x1 card for connection to Industrial Ethernet (10/100/1000 Mbit/s), with 2-port switch (RJ45) via HARDNET-IE S7 and S7-REDCONNECT. For operating system support, see SIMATIC NET Software	6GK1 162-3AA00
		CP 1628 communications processor PCI Express x1 card for connection to Industrial Ethernet (10/100/1000 Mbit/s), with 2-port switch (RJ45) and integral security (firewall, VPN) via HARDNET-IE S7 and S7-REDCONNECT. For operating system support, see SIMATIC NET Software	6GK1 162-8AA00

Overview

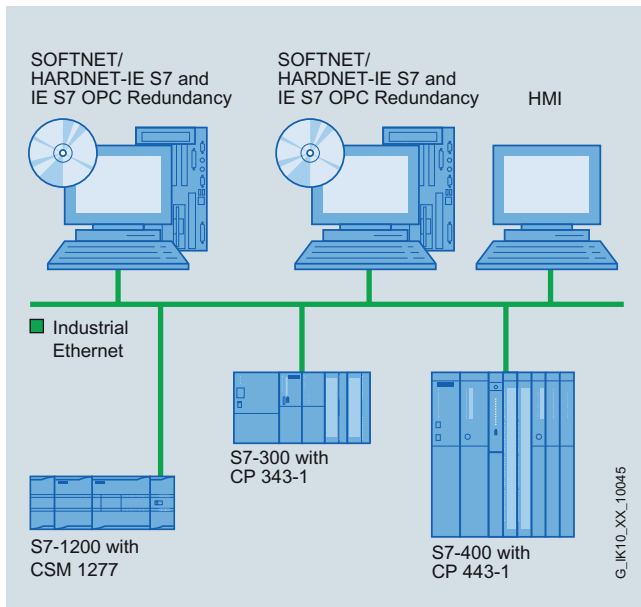

System configuration SOFTNET for Industrial Ethernet

ISO	TCP/UDP	PN	MRP	OPC	PG/OP	S7/S5	IT
●	●			●	●	●	

- Software for coupling programming devices/workstations to automation systems
- Communication services:
 - PG/OP communication
 - S7 communication
 - Open communication (SEND/RECEIVE)
- Can be used with
 - Layer 2 Ethernet card (PCI/PCIe)
 - Integrated Industrial Ethernet interface, e.g. CP 1612 A2
 - Modem (Remote Access Service RAS)
- Complete protocol stack as a software package
- Increased availability thanks to additional option packages such as OPC Server Redundancy

Technical specifications

Performance data

S7 and PG/OP communication (number of operable connections)

- SOFTNET-IE S7
- SOFTNET-IE S7 Lean

max. 64
max. 8

SIMATIC programming devices

Communications software

SOFTNET for Industrial Ethernet

Ordering data	Order No.	Order No.
SOFTNET S7 for Industrial Ethernet Software for S7 and open communication, incl. OPC server, PG/OP communication, and NCM PC, runtime software, software and electronic manual on CD-ROM, license key on a USB stick, Class A		SOFTNET-PG for Industrial Ethernet Software for PG/OP communication, runtime software, software and electronic manual on CD-ROM, license key on USB flash drive, Class A
SOFTNET-IE S7 V8.2 For 32/64-bit Windows 7 Professional/Ultimate; for 64-bit: Windows 2008 Server R2; German/English up to 64 connections • Single License for one installation	6GK1 704-1CW08-2AA0	SOFTNET-IE PG V8.2 For 32/64-bit: Windows 7 Professional/Ultimate; for 64-bit: Windows 2008 Server R2; German/English • Single License for one installation
SOFTNET-S7 Edition 2008 (V7.1) for Industrial Ethernet For 32 Bit Windows XP Professional SP2/3; Windows 2003 Server R2, SP2; Windows Vista Business/Ultimate SP1; Windows 2008 Server; English/German up to 64 connections • Single License for one installation	6GK1 704-1CW71-3AA0	SOFTNET-PG Edition 2008 (V7.1) for Industrial Ethernet For 32 Bit Windows XP Professional SP2/3; Windows 2003 Server R2, SP2; Windows Vista Business/Ultimate SP1; Windows 2008 Server; English/German • Single License for one installation
Software Update Service For 1 year with automatic extension; requirement: current software version	6GK1 704-1CW00-3AL0	Software update For 1 year with automatic extension; requirement: current software version
Upgrade • From Edition 2006 to Edition 2008 or V8.2 • From V6.0, V6.1, V6.2 or V6.3 to Edition 2008 or V8.1	6GK1 704-1CW00-3AE0 6GK1 704-1CW00-3AE1	Upgrade • From Edition 2006 to Edition 2008 or V8.1 • From V6.0, V6.1, V6.2 or V6.3 to Edition 2008 or V8.1
SOFTNET-IE S7 REDCONNECT VM V8.2 Software for fail-safe S7 communication via redundant networks, incl. S7 OPC server, HARDNET-IE S7, runtime software, software and electronic manual on CD-ROM, license key on USB stick, Class A for 32/64-bit: Windows 7 Professional/Ultimate; for 64-bit: Windows 2008 Server R2; German/English; • Single License for one installation	6GK1 704-0HB08-2AA0	IE S7 OPC Redundancy Software for redundant OPC servers in the environment of Industrial Ethernet software, S7 products, runtime software, software and electronic manual on CD-ROM, license key on USB flash drive, Class A
SOFTNET-IE S7 Lean Edition V8.2 Up to eight connections • Single License for one installation	6GK1 704-1LW08-2AA0	IE S7 OPC Redundancy V8.2 for 64-bit: Windows 2008 Server R2; German/English • Single License for one installation • Software Update Service for one year, with automatic extension; requirement: current software version
SOFTNET-S7 Lean Edition 2008 (V7.1) for Industrial Ethernet Up to eight connections • Single License for one installation	6GK1 704-1LW71-3AA0	
Software Update Service For 1 year with automatic extension; requirement: current software version	6GK1 704-1LW00-3AL0	
Upgrade • From Edition 2006 to Edition 2008 or V8.1 • From V6.0, V6.1, V6.2 or V6.3 to Edition 2008 or V8.1	6GK1 704-1LW00-3AE0 6GK1 704-1LW00-3AE1	

Overview

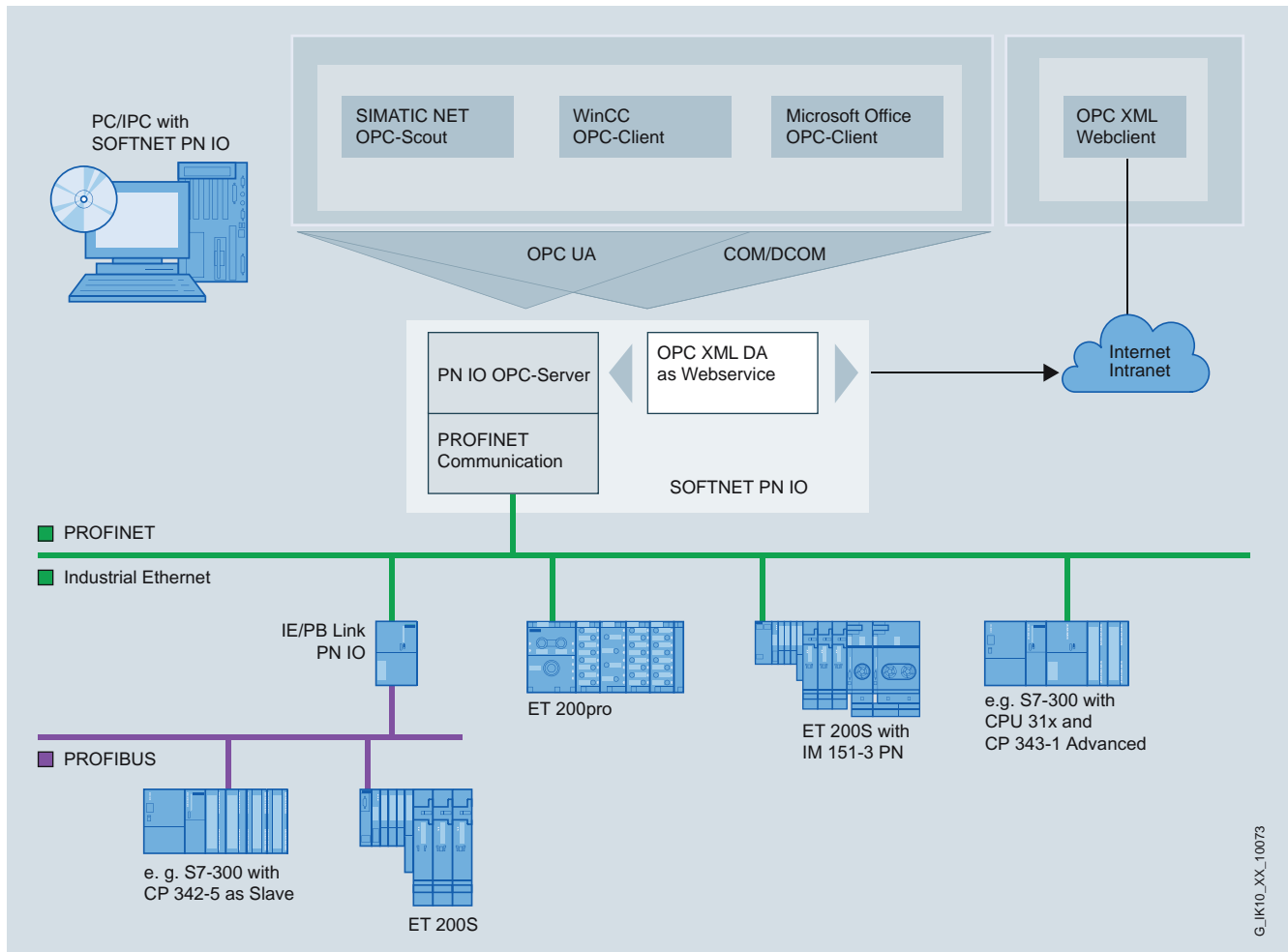

G_IK10_XX_10073

PC with SOFTNET PN IO as PROFINET IO Controller

ISO	TCP/UDP	PN	MRP	OPC	PG/OP	S7/S5	IT
	●	●		●			

- Software with PROFINET IO Controller function for coupling PG/PC and IPC with PROFINET IO Devices
- Possible applications:
 - PC-based control systems
 - HMI systems
 - Test applications
- Communication services:
 - PROFINET IO Controller
- Can be used with
 - Integrated interfaces of SIMATIC PG/PC
 - You can find more information about the environment of use at www.siemens.com/simatic-net/ik-info
- Cost-effective solution for the low-end performance range
- OPC server for I/O interfacing over PROFINET included in scope of supply

SIMATIC programming devices

Communications software

SOFTNET PN IO

Technical specifications

SOFTNET PN IO	
Performance data	
• Number of operable IO devices	Max. 64
• Number of external IO-lines in one central rack	Max. 1
• Size of IO data areas overall	
- I/O input area	Max. 2 KB
- I/O output area	Max. 2 KB
• Size of I/O data area per connected I/O device	
- I/O input range	Max. 1433 byte
- I/O output range	Max. 1433 byte

Ordering data

Order No.

SOFTNET PN IO Software for PROFINET IO Controller with OPC server and NCM PC, runtime software, software and electronic manual on CD-ROM, license key on USB flash drive, Class A,	
SOFTNET-IE PN IO V8.2 for 32/64-bit: Windows 7 Professional/Ultimate; for 64-bit: Windows 2008 Server R2 German/English • Single License for one installation	6GK1 704-1HW08-2AA0
SOFTNET PN IO Edition 2008 (V7.1) for 32-bit Windows XP Professional SP 2/3; Windows 2003 Server R2, SP2; Windows Vista Business/Ultimate SP1; Windows 2008 Server; German/English • Single License for one installation	6GK1 704-1HW71-3AA0
Software Update Service For 1 year with automatic extension; requirement: current software version	6GK1 704-1HW00-3AL0
Upgrade • From Edition 2006 to SOFTNET PN IO Edition 2008 or V8.1 • From V6.0, V6.1, V6.2 or V6.3 to SOFTNET PN IO Edition 2008 or V8.1	6GK1 704-1HW00-3AE0 6GK1 704-1HW00-3AE1

Overview

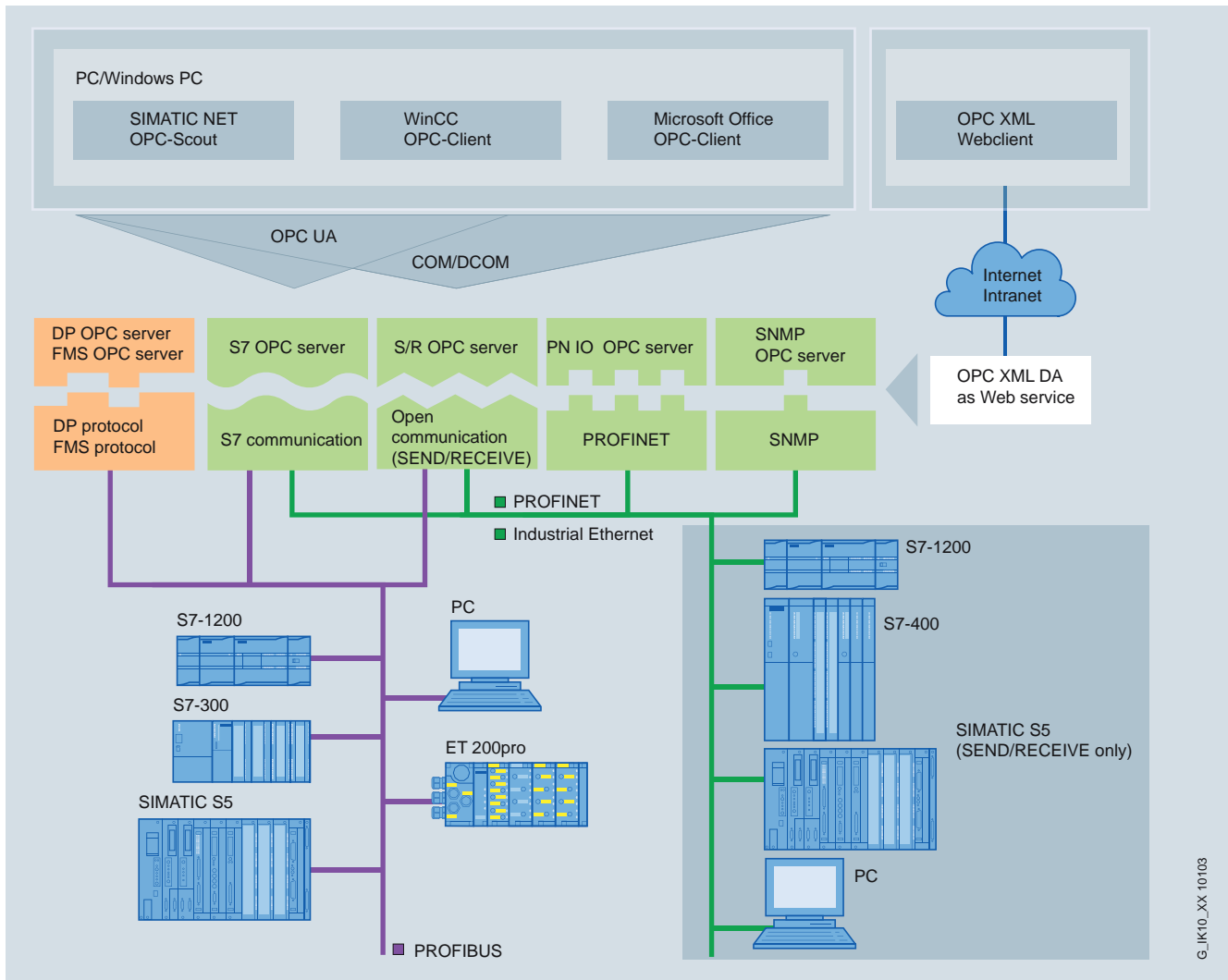

System integration with OPC server

OPC (**O**penness, **P**roductivity & **C**ollaboration) is a standardized, open, and vendor-independent interface that is widely used in automation.

A fundamental distinction is made between the classic OPC and its consistent further development OPC UA (**U**nified **A**rchi-**t**eecture). Smooth migration to the new OPC UA standard is easily possible; this offers further value added, such as security. The SIMATIC NET OPC servers offer the two interfaces OPC UA and classic OPC for SIMATIC S7 and PROFINET.

- The appropriate OPC servers are included in the scope of supply of the respective communication software
- Standardized, open multi-vendor interface
- It permits interfacing of OPC-capable Windows applications to S7-communication, open communication (SEND/RECEIVE), PROFINET and SNMP.
- Increased availability thanks to additional option packages such as OPC server redundancy
- OPC Scout with browser functionality as an OPC client and OCX Data Control/.NET Data Control for simple OPC client creation

SIMATIC programming devices

Communications software

OPC server for Industrial Ethernet

Technical specifications

Programming	<ul style="list-style-type: none"> • Synchronous and asynchronous reading and writing of variables • Monitoring of variables using the OPC server with a signal to the client when a change occurs • Use of quantity operations; so a large amount of data can be processed in a short time.
Interfaces	<ul style="list-style-type: none"> • Custom Interface (C++, NET) for high OPC performance • Automation Interface (VB, Excel, Access, Delphi, ...) for ease-of-use • Graphics with OCX or .NET Data Control; for configuring instead of programming • OPC XML-Interface for Data Access

Products

<p>Industrial Ethernet</p> <ul style="list-style-type: none"> • HARDNET-IE S7, SOFTNET-IE S7, SOFTNET-IE S7 Lean • SNMP OPC server • S7 OPC Redundancy 	<p>include OPC servers for:</p> <p>S7-OPC server for S7 communication, XML-DA</p> <p>S5-OPC server for open communication¹⁾ communication, XML-DA</p> <p>SNMP OPC server for SNMP protocol access; XML-DA</p> <p>Redundant S7-OPC server for S7 communication</p>
<p>PROFINET</p> <ul style="list-style-type: none"> • SOFTNET-IE PN IO 	<p>PN IO OPC server for PROFINET IO communication; XML-DA</p>
<p>PROFIBUS</p> <ul style="list-style-type: none"> • HARDNET-PB DP, SOFTNET-PB DP, SOFTNET-PB DP slave • FMS-5613 • HARDNET-PB S7, SOFTNET-PB S7 • S7 OPC Redundancy 	<p>DP-OPC server for PROFIBUS DP communication; XML-DA</p> <p>FMS-OPC server for PROFIBUS FMS communication; XML-DA</p> <p>S7-OPC server for S7 communication, XML-DA</p> <p>Redundant S7-OPC server for S7 communication</p>

¹⁾ also S5-compatible communication

Ordering data

SNMP OPC server

Status monitoring of SNMP-capable devices in any OPC client systems; e.g. SIMATIC WinCC/PCS 7

S7 OPC Redundancy

Software for redundant OPC servers in the environment of Industrial Ethernet software, S7 products, runtime software, software and electronic manual on CD-ROM, license key on USB flash drive, Class A

S7 OPC Redundancy V8.2

For 64-bit: Windows 2008 Server R2; German/English

- Single License for one installation

Software Update Service

For 1 year with automatic extension; requirement: current software version

Order No.

See SNMP OPC server

6GK1 706-1CW08-2AA0

6GK1 706-1CW00-3AL0

Overview

- Access to variables in PROFINET CBA components over the OPC interface
- Use of the objects and symbols defined using the PROFINET engineering tool SIMATIC iMap and STEP 7
- Adding PROFINET functionality to existing installations. This enables it to be used in parallel with other communication protocols such as S7 communication with SOFTNET-S7 for Industrial Ethernet.
- OPC Scout as an OPC client with browser functions for the variables of the PROFINET CBA components

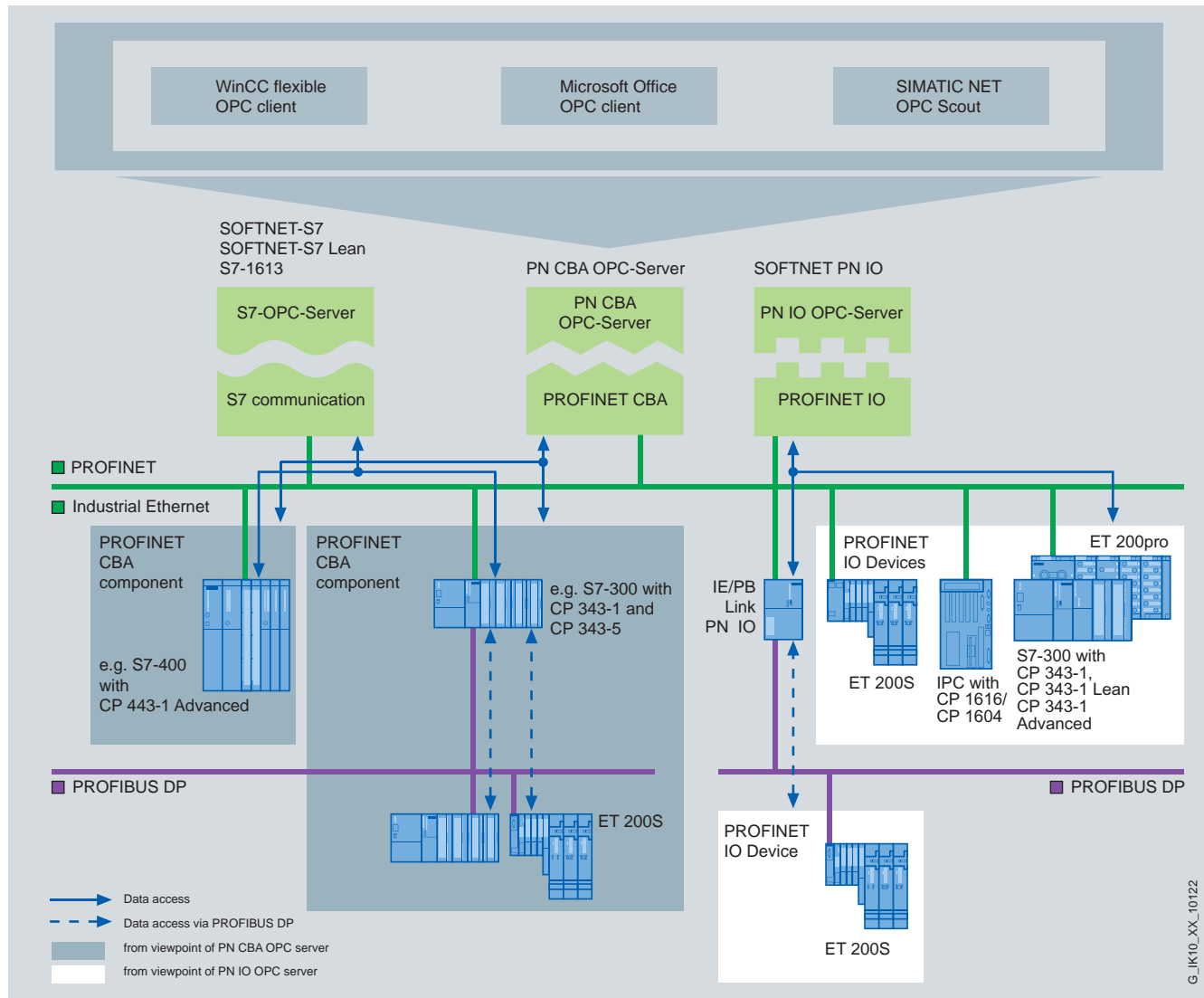

System integration with the PN CBA OPC server

SIMATIC programming devices

Communications software

PN CBA OPC server

Technical specifications		Ordering data	Order No.
	PN CBA OPC server	PN CBA OPC Server Edition 2008	
Programming	<ul style="list-style-type: none"> Open and standardized Synchronous and asynchronous reading and writing of variables Monitoring of variables by the OPC server with an alarm message to the client in the case of a change Use of batch operations, so a large volume of data can be processed in a short time 	PROFINET OPC server for CBA; runtime software, software and electronic manual on CD-ROM, license key on USB flash drive, Class A, for 32-bit Windows XP Professional SP 2/3; Windows 2003 Server R2, SP2; German/English	
Interfaces	<ul style="list-style-type: none"> Custom Interface (C++, .NET) Automation Interface (Visual Basic, Excel, Access,...) OPC Data Control OPC XML Interface for Data Access 	<ul style="list-style-type: none"> Single license for one installation Software Update Service for one year, with automatic extension; requirement: Current software version 	6GK1 706-0HB71-3AA0 6GK1 706-0HB00-3AL0
Protocols	<ul style="list-style-type: none"> DCOM protocol 	<ul style="list-style-type: none"> Upgrade from Edition 2006 and higher to Edition 2008, single license 	6GK1 706-0HB00-3AE0
Configuration	Configuring software for PROFINET SIMATIC iMap	<ul style="list-style-type: none"> Upgrade from V6.0, V6.1, V6.2 or V6.3 to Edition 2008, Single License 	6GK1 706-0HB00-3AE1
	PROFINET communication (CBA)	Software iMap V3.0	
<ul style="list-style-type: none"> Number of communication partners Number of connections 	max. 228 max. 10,000	for configuring PROFINET CBA Requirement: Windows 2000 Prof. with Service Pack 4 or later or Windows XP Prof. with Service Pack 1 or later or Windows 2003 Server with Service Pack 1 or later; on PG or PC with Pentium processor, min. 1 GHz; STEP 7 V5.3 or later with Service Pack 3, PN OPC Server V6.3 or later Type of supply: German, English with electronic documentation	6ES7 820-0CC04-0YA5 6ES7 820-0CC01-0YX2 6ES7 820-0CC04-0YE5
		<ul style="list-style-type: none"> Single license Software Update Service Upgrade to V3.0, single license 	

Overview

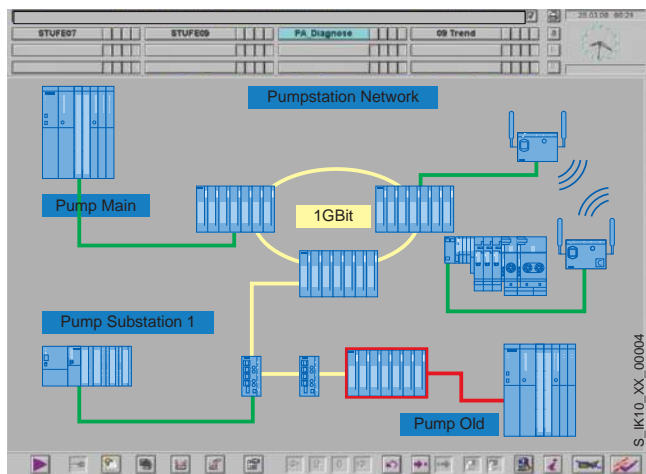

- Status monitoring of SNMP-capable devices in any OPC client systems; e.g. SIMATIC WinCC/PCS 7
- Easy access to SNMP-capable devices over the OPC interface
- Devices without SNMP agents can be monitored using the ping mechanism
- Configuring with STEP 7 or NCM PC
- Ready-to-use SNMP diagnostics profiles for Siemens devices, e.g. SCALANCE X/W
- Generation of any SNMP diagnostics profiles by means of the integral MIB compiler
- Easy setup of the monitored devices with the help of an autodiscovery function

Ordering data

SNMP OPC server

Including MIB compiler; single license for one installation of runtime software; software and electronic manual on CD-ROM; license key on USB stick, Class A;

SNMP OPC Server Basic

Administration of up to 20 IP addresses

- **Basic V8.2** for 32/64-bit: Windows 7 Professional/Ultimate; for 64-bit: Windows 2008 Server R2; Single license for one installation
- **Basic 2008 (V7.1)** for 32-bit Windows XP Professional SP2/3; Windows 2003 Server R2, SP2; Windows Vista Business/Ultimate SP1; Windows 2008 Server; Single license for one installation

Software Update Service SNMP OPC Server Basic

For 1 year with automatic extension; requirement: current software version

Upgrade SNMP OPC Server Basic

- From Edition 2006 to Edition 2008 or V8.1
- From V6.0, V6.1, V6.2 or V6.3 to Edition 2008 or V8.1

Order No.

6GK1 706-1NW08-2AA0

6GK1 706-1NW71-3AA0

6GK1 706-1NW00-3AL0

6GK1 706-1NW00-3AE0

6GK1 706-1NW00-3AE1

Order No.

SNMP OPC Server Extended

Administration of up to 200 IP addresses

- **Extended V8.2** for 32/64-bit: Windows 7 Professional/Ultimate; for 64-bit: Windows 2008 Server R2; Single license for one installation
- **Extended 2008 (V7.1)** for 32-bit Windows XP Professional SP2/3; Windows 2003 Server R2, SP2; Windows Vista Business/Ultimate SP1; Windows 2008 Server; Single license for one installation

Software Update Service SNMP OPC Server Extended

For 1 year with automatic extension; requirement: current software version

Upgrade SNMP OPC Server Extended

- From Edition 2006 to Edition 2008 or V8.1
- From V6.0, V6.1, V6.2 or V6.3 to Edition 2008 or V8.1

SNMP OPC Server Power Pack

For upgrade from SNM OPC Server Basic to SNM OPC Server Extended

Power Pack V8.2

Power Pack Edition 2008 (V7.1)

6GK1 706-1NX08-2AA0

6GK1 706-1NX71-3AA0

6GK1 706-1NX00-3AL0

6GK1 706-1NX00-3AE0

6GK1 706-1NX00-3AE1

6GK1 706-1NX08-2AC0

6GK1 706-1NX71-3AC0

SIMATIC programming devices

Notes

12

Overviews

**13/2** SIMATIC PCS 7**13/5** SIMATIC HMI**13/10** SIMATIC NET**13/11** SIMATIC Ident

Overview (continued)

Central engineering

SIMATIC PCS 7 convinces with graded functional diversity, consistent operator control philosophy, and uniformly structured engineering and management tools. A central engineering system with a coordinated range of tools for integrated system engineering and configuring of batch automation, safety functions, material transport or telecontrol systems creates value added over the entire life cycle. Reductions in configuring and training costs minimize the total cost of ownership (TCO) over the entire plant life cycle.

Functional diversity

Depending on the typical process automation or customer-specific requirements, SIMATIC PCS 7 can be functionally expanded for the following, for example:

- Batch process automation (SIMATIC BATCH)
- Route control for material transport (SIMATIC Route Control)
- Functional safety and protection functions (Safety Integrated for Process Automation)
- Telecontrol of remote units (SIMATIC PCS 7 TeleControl)
- Automation of electrical switchgear (SIMATIC PCS 7 Power-Control)

Further additional functions that are also integrated, or can be integrated, seamlessly into the control system make optimization of processes and reductions in operating costs possible. SIMATIC PCS 7 has, for example, tools for energy and asset management, and it offers higher quality closed-loop control functions, as well as industry-specific automation solutions and libraries.

Customized performance

Thanks to a unique scalable system architecture, SIMATIC PCS 7 creates the ideal basis for cost-effective implementation of individual automation solutions.

SIMATIC PCS 7 users derive sustained profit from a modular system platform based on standard SIMATIC components. Its uniformity enables flexible scaling of hardware and software, as well as perfect interaction both within the system and beyond system limits. The architecture of the SIMATIC PCS 7 process control system is designed in such a manner that instrumentation and control can be configured according to customer requirements and optimally adapted to the dimensions of the plant. The control system can be subsequently expanded or reconfigured at any time if there is an increase in capacity or a technological modification. When the plant grows, SIMATIC PCS 7 simply grows along with it – without the provision of expensive reserve capacities.

Performance in engineering

With regard to planning and engineering, performance can be equated with minimizing time and costs. For this purpose, SIMATIC PCS 7 together with COMOS offers an integrated planning workflow from the process description through to the automation program.

A standardized system interface, strictly object-oriented working, and centralized data management mean data consistency across all planning steps, including automatically updated system documentation.

Engineering using other planning tools is also mastered extremely efficiently by SIMATIC PCS 7 by means of the Advanced Engineering System (AdvES). This can be used to import plant data from CAD/CAE tools without problems. It additionally supports automatic generation of the AS configuration thanks to simple multiplication of process tag types and model solutions, as well as parameter processing.

Performance in operation

SIMATIC PCS 7 offers impressively high flexibility, plant availability, and security of investment.

With its excellent operator system, SIMATIC PCS 7 facilitates user-friendly and safe control of the process.

Effective Advanced Process Control (APC) functions, and well as the key performance indicators and product quality, imply additional potential for optimization.

Process control and maintenance

The operator system of SIMATIC PCS 7 is used to monitor process operation using various views, and permits interventions when necessary. Its architecture is flexible and scalable – from single-user systems up to multi-user systems with a redundant client/server architecture. The operator interface takes account of the current specifications of NAMUR (user association of automation technology in the process industries) and PI (Profibus International) and offers a high level of user-friendliness for simple, intuitive interaction with the plant. Ergonomic symbols, task-oriented faceplates, uniform representation of status information, and optimized alarm functions allow safe process control.

The alarm management function integrated in SIMATIC PCS 7 is able to focus on essential alarms and to specifically guide the operator in exceptional circumstances. In this way, it systematically reduces the workload of operating staff.

Preventive and predictive maintenance strategies reduce total cost of ownership. With the SIMATIC PCS 7 Maintenance Station, maintenance personnel always have a watchful eye on critical production equipment such as pumps, valves, distillation columns or motors, and can carry out the relevant maintenance measures in good time before servicing is required – independent of the maintenance plan and without the risk of an unscheduled plant standstill.

Overviews

SIMATIC PCS 7

Introduction

Overview (continued)

Process optimization

SIMATIC PCS 7 supports process optimization in various ways, including:

- Control Performance Monitoring
- Advanced Process Control
- Process Historian

The Control Performance Monitoring function monitors and signals the control quality of the closed-loop control block. If the performance declines, the controller can be optimized in good time or specific maintenance measures can be initiated.

The integrated I&C libraries of SIMATIC PCS 7 also provide higher quality closed-loop control functions with which cost-effective Advanced Process Control applications can be implemented: multi-variable control, predictive control, or override control. This enables profitability, product quality, safety, and environmental protection to be effectively improved in small and medium-sized plants.

Current and historic process data form the basis of all optimization. Secure and user-friendly real-time data storage and analysis is handled using the Process Historian. The process values, messages, and batch data managed in the database of the Process Historian can be called extremely rapidly. User-specific processing and visualization of this historic data are supported by the information server, which is a reporting system based on the Microsoft Reporting Services.

Additional functionality with add-on products

Modularity, flexibility, scalability, and the openness of SIMATIC PCS 7 offer optimal prerequisites for integrating supplemental components and solutions in the process control system in an applicative manner and thus extend and round off its functionality.

Many supplementary add-on products for SIMATIC PCS 7 have been developed by Siemens as well as by external partners (see Catalog "Add-ons for the SIMATIC PCS 7 Process Control System"). These software packages and hardware components authorized by the system manufacturer enable cost-effective implementation of SIMATIC PCS 7 for special automation tasks.

Migration

By the time the installed base is no longer competitive or the procurement of spare parts is becoming problematic, modernization is inevitable.

The migration from legacy systems from Siemens and from other suppliers is supported by a host of innovative products and solutions. Increasing use is being made of the universal, OPC-coupled SIMATIC PCS 7/Open OS, with which any systems can be integrated into the uniform operating concept of SIMATIC PCS 7.

The migration experts at Siemens have a wealth of experience and support migration projects worldwide with analyses, concepts, and powerful tools.

Overview

Gain transparency and lower costs: SIMATIC HMI operator control and monitoring systems

The interface between human and machine – the human machine interface or HMI for short – connects the world of automation with the individual requirements of the operator.

Human machine interfacing is about managing the process, optimizing machine and system operation, availability and productivity.

Everything from a single source

With SIMATIC HMI, Siemens Automation and Drives offers a complete range of innovative and low-cost products and systems for the multi-faceted tasks of operator control and monitoring: Ranging from operator panels and visualization software for operator control and monitoring at the machine through to SCADA systems for widely differing requirements in process visualization. For special requirements, optimally adapted products are offered such as especially rugged HMI devices with all-round protection for mounting on support arms/pedestals, or operator panels with stainless steel front for use in the food and beverages industry. Of course, individual, customer-specific requirements can also be implemented.

Perfectly equipped for integration in the world of automation

With their open, standardized interfaces in hardware and software, SIMATIC HMI products can be integrated at any time in the production and automation level as well as in the company management level. Connectability to almost every controller on the market as well as multiple language capability of the configuration and visualization software – including Asian ideographic languages, of course – facilitate operation worldwide.

Increased production transparency through Plant Intelligence

Plant Intelligence is based on the rational use of information to improve processes within the company. It is designed to lower plant costs, consolidate and improve quality, avoid wastage, make better use of production facilities, and ultimately ensure greater efficiency and cost effectiveness within the company. WinCC provides the best conditions for achieving this since WinCC features an integrated Historian for acquiring important production data. Using intelligent functions and tools, these process data can be edited into information necessary for making decisions and can be made available throughout the company whenever and wherever it is required – for operators as well as production managers or anyone else within the company.

Even the WinCC basic system provides a wealth of display and evaluation functions, such as the statistics function for the message and measured value logs. WinCC options for IT & business integration make additional "smart" tools available for optimizing production using Plant Intelligence.

Integrated into the World Wide Web

SIMATIC HMI transforms the Internet into a control desk – within a plant as well as in the worldwide network. Using the WinCC/Web Navigator, you can monitor and operate plants over the Internet or over the internal corporate intranet. Thin client solutions can be used to integrate rugged, local devices which simultaneously establish the connection between the automation level and the control center. And over a wireless LAN or cell phone connection, you can use mobile thin clients such as laptop computers, PDAs (personal digital assistants), or WebPads.

In this way, process, service or management information can be made individually available to users. At the machine level, many control units support remote operation, e.g. as a link between the automation level and the control room through to service and diagnostics over the Internet.

For operation and monitoring at the machine, concepts with so-called Sm@rtClients and servers facilitate plant-wide access to variables and graphics, distributed operator stations as well as remote operation and diagnostics via the Internet – also in conjunction with SIMATIC Panels.

Traceability and simple validation

SIMATIC HMI software with "FDA options" provides a high degree of support to machine and plant manufacturers who must fulfill high quality requirements, both with respect to the products to be manufactured as well as to the manufacturing processes themselves. These options simplify plant validation enormously and thus provide the most convincing and comprehensive solution for the requirements of these industries. They support the user in fulfilling high quality requirements as specified by the FDA (Food and Drug Administration) 21 CFR Part 11 for the food, beverages and pharmaceutical industries.

Increased plant availability

All operator panels and Panel PCs are designed for harsh industrial use. Redundant process visualization systems ensure a high degree of plant availability during normal operation.

Distributed operator control concepts

SIMATIC HMI offers different solutions for different requirements for operator control of large machines and plants spread over extensive areas. Thus, the Sm@rtAccess option of the SIMATIC WinCC flexible visualization software, for example, allows HMI devices such as panels, thin clients and PCs plant-wide access via PROFINET/Ethernet to current process values and the local screen images of all involved stations.

SIMATIC HMI software offers appropriate options for diagnostics, maintenance and telecontrol over the Internet from local operator stations.

As remote operator stations, SIMATIC Thin Clients make the functionality of machine-level panels available in the control room or in the office, thanks to their connection to PROFINET/Ethernet, and in the other direction, they bring SIMATIC WinCC, office or IT functionality straight to the machine.

In PC-based applications, the computing unit and the operating unit of a Panel PC 677B can be separated from each other by up to 30 m. When using PCs such as the SIMATIC Rack or Box PC, a SIMATIC Flat Panel monitor can also assume the function of the operating unit at a distance of up to 30 m.

Overviews

SIMATIC HMI

Introduction

Overview (continued)

More than just operator control and monitoring

The Multi Panels under Windows CE combine the advantages of two worlds: On the one hand, the ruggedness of an operator panel and on the other hand the flexibility typical of a PC. Apart from conventional operator control and monitoring, other automation functions such as control functions can execute simultaneously. And for PC-based Automation, the SIMATIC Panel PCs are available as a compact automation platform – the embedded versions being especially compact and rugged, as well as maintenance-free.

All the advantages of Totally Integrated Automation

With Totally Integrated Automation (TIA), Siemens is the only supplier who offers a system-wide, integrated product and system range for automating the complete production workflow. The distinguishing feature of TIA is that it is completely integrated. The reduced number of interfaces results in very clear structures. This reduces time and costs required for engineering the automation solution and increases the availability of the plant.

In conjunction with other SIMATIC components, SIMATIC HMI also supports system diagnostics and process diagnostics during normal operation. You can start STEP 7 diagnostics directly from WinCC for comprehensive error diagnostics from the circuit diagram through to the PLC program. The SIMATIC Maintenance Station visualizes the maintenance information for the automation technology of a system – from the controller and network components to switchgear, protective equipment and control devices and the drives. This gives a clear overview of the status of the automation at any time.

A competent partner for automation solutions

With SIMATIC HMI, you not only get excellent products to suit your requirements, but we will also support you in selecting a partner for your automation solution. Within our worldwide network of Siemens Automation Solution Partners, you will find competent contact partners in your area who are always up-to-date with SIMATIC HMI technology. The Siemens-internal WinCC Competence Centers implement technology-specific products as well as customer and industry-specific solutions on the basis of WinCC. WinCC specialists are external system integrators who combine their WinCC expertise with their industry and technology know-how to create tailor-made, cost-effective solutions. Numerous products from our partners that interact perfectly with WinCC are available as WinCC Add-ons.

Investment protection is included

Our many years of experience in the automation engineering sector are to your advantage. The same applies to our global service network with its expert support. Further services, such as a software update service, training, ordering over the Internet, etc. round off what we have to offer.

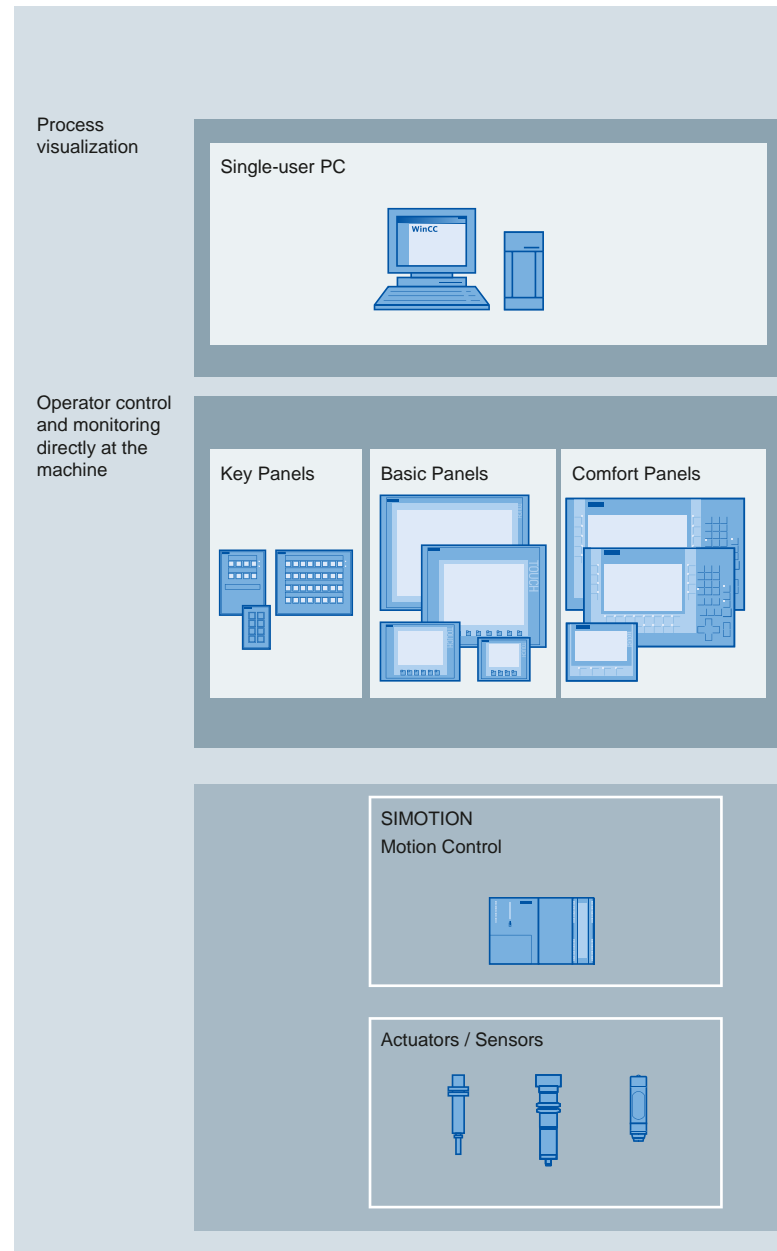

SIMATIC HMI – The whole world of human-machine interfacing

Overview (continued)

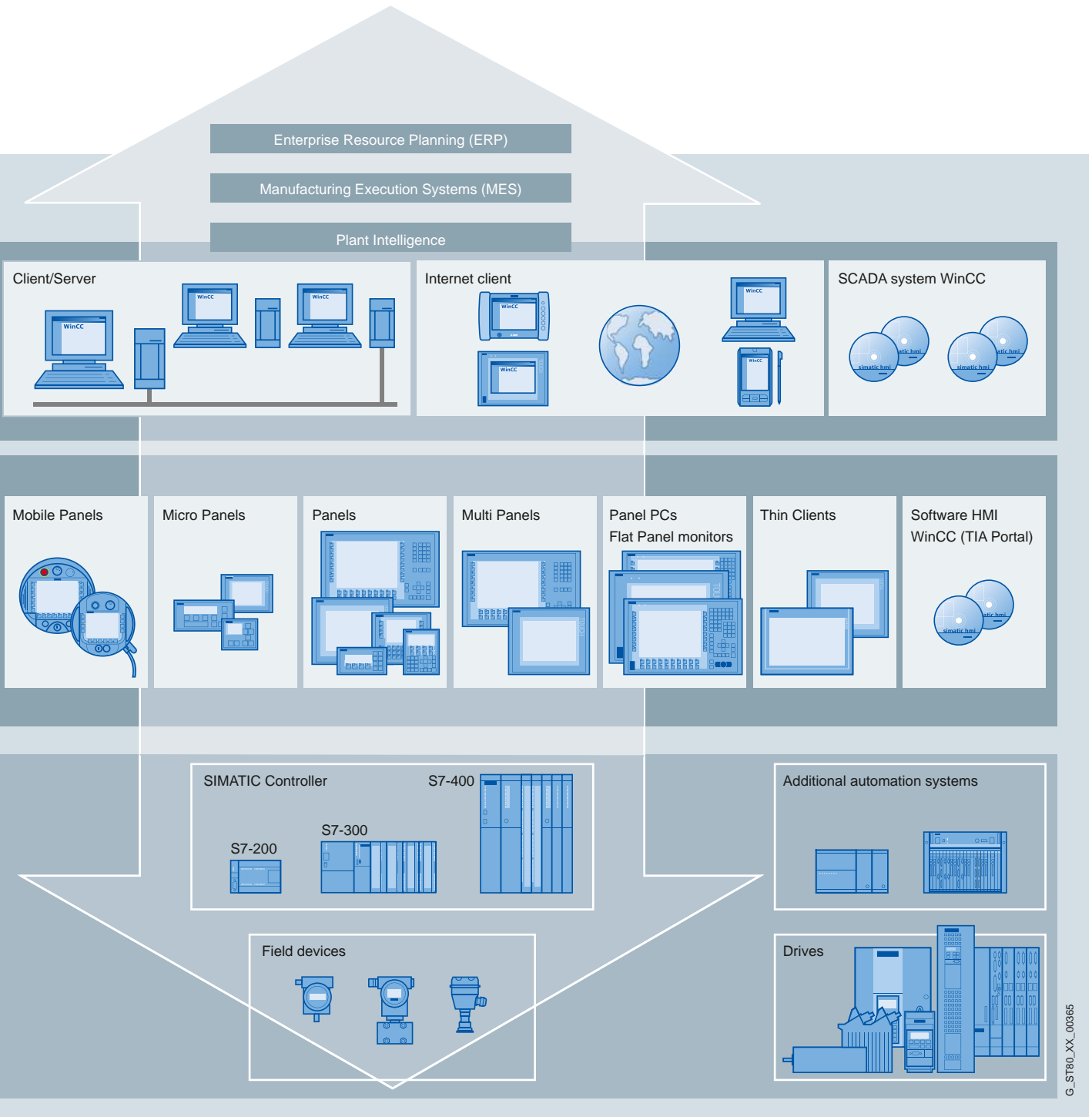

G_ST80_XX_00365

Overviews

SIMATIC HMI

Introduction

Overview (continued)

HMI devices

SIMATIC HMI Key Panels

Operator panels with bus capability for easy and direct operation of machines.

SIMATIC HMI Basic Panels

HMI devices with basic functionality for low-cost operator control and monitoring of simple applications.

SIMATIC HMI Comfort Panels

HMI devices with high-end functionality for demanding applications.

SIMATIC HMI Mobile Panels

Mobile HMI devices with or without cables for direct operator control of the plant and machine from any location.

HMI devices for special requirements

Fully enclosed HMI devices for SIMATIC

The fully enclosed SIMATIC HMI devices (MP 377 PRO, HMI IPC477C PRO, Flat Panel PRO and Thin Client PRO) are ideal for industrial applications in harsh environments due to their extremely robust design. They are, for example, specially designed for mounting on a support arm/stand.

Devices with stainless steel fronts

Panels and Panel PCs with touch screens and stainless steel fronts are designed for machine-level operator control and monitoring in the food, beverages and tobacco industry.

HMI devices for hazardous areas

Intrinsically safe Panel PCs and thin clients that were specifically developed for hazardous areas.

HMI software

Flexibility in any HMI application – from Basic Panels through to process visualization

SIMATIC WinCC in the Totally Integrated Automation Portal (TIA Portal) is part of a new, integrated engineering framework which offers a uniform engineering environment for programming and configuration of control, visualization and drive solutions.

WinCC in the TIA Portal is the software for all HMI applications ranging from the simplest operation solutions with Basic Panels to SCADA applications on PC-based multi-user systems. SIMATIC WinCC V7 remains available for extremely complex applications featuring Plant Intelligence solutions, integrated archive servers or redundant architectures, whereas WinCC Open Architecture addresses applications with demanding customization requirements, also on non-Windows platforms.

SIMATIC WinCC V7 remains available for extremely complex applications featuring Plant Intelligence solutions, integrated archive servers or redundant architectures, whereas WinCC Open Architecture addresses applications with demanding customization requirements, also on non-Windows platforms.

Overview (continued)

SIMATIC PC-based Automation

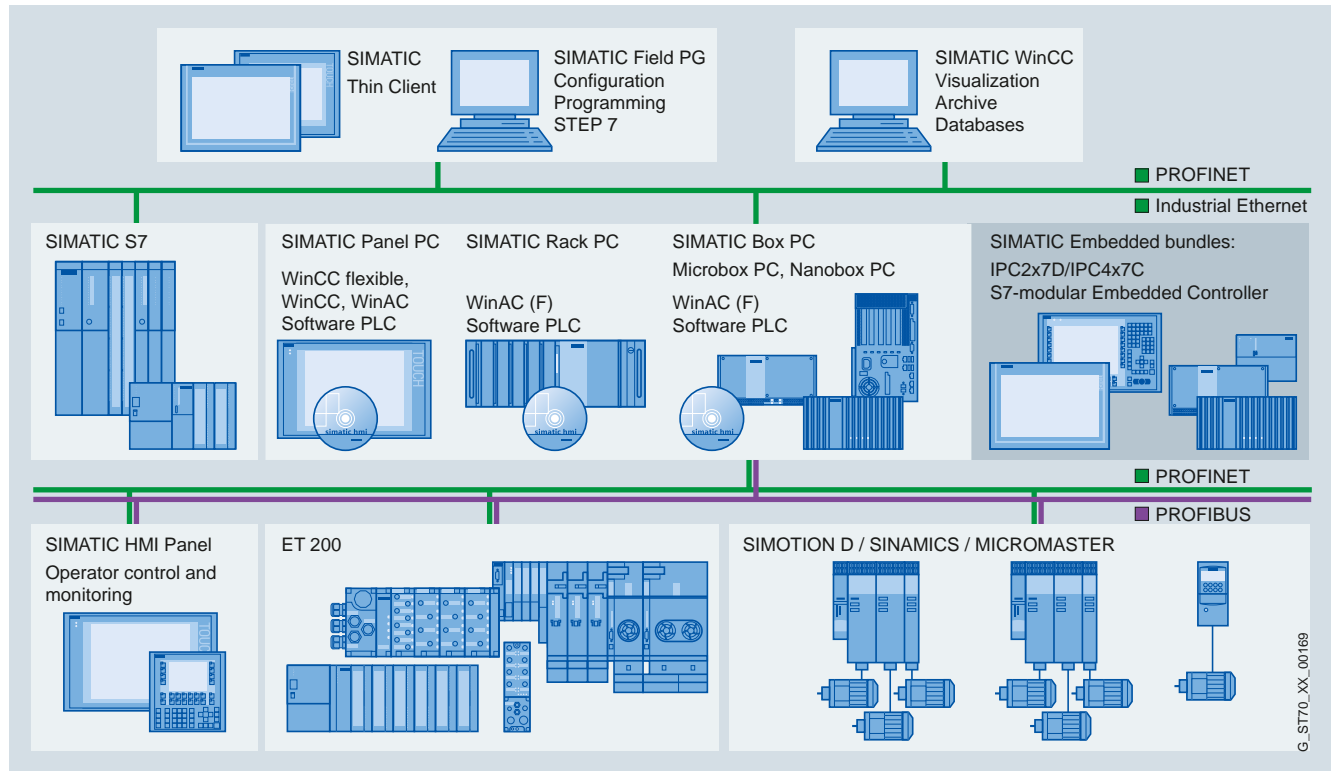

Industrial PCs

Our reliable and innovative industrial PCs are the optimal PC hardware platform for PC-based Automation from Siemens.

PC-based controllers

Siemens has developed a wide range of coordinated hardware and software components for PC-based Automation. Focal point: SIMATIC PC-based Control with SIMATIC WinAC, the open, flexible and reliable software controller for your PC-based automation solution, also approved by the German Technical Inspectorate and fail-safe.

Embedded controllers

SIMATIC S7-mEC is a modular controller in S7-300 design with the latest embedded PC technology. It comprises the EC31 (CPU) and optionally available expansion modules.

Embedded bundles with industrial PCs

Embedded bundles based on the embedded industrial PCs are extremely compact, robust, and maintenance-free systems for use at machine level. The functions of PC-based Control (also fail-safe) and/or visualization are already pre-installed and ready to use.

Software packages for SIMATIC IPC

SIMATIC industrial PCs are offered with low-cost software packages. For the runtime versions with the visualization software products SIMATIC WinCC V7 or WinCC Runtime Professional or WinCC Runtime Advanced, as well as the software controller SIMATIC WinAC RTX (F). The simultaneous purchase of industrial PC and software package results in the price advantage.

Industrial monitors and thin clients

Flexible distributed operating concepts can be implemented via Flat Panel monitors and thin clients. These are industry-standard LCD monitors with high-luminance displays that can be placed up to 30 m away from the PC, or high-performance industrial thin clients. SIMATIC ITC, for individual or even multiple operator stations, can be placed as far away as required via Industrial Ethernet.

Customized Automation

With Customized Automation, field-proven SIMATIC, SIMATIC IPC and SIMATIC HMI standards are converted into individual products and systems – tailored precisely to the customer's requirements. The portfolio covers the hardware and software range, as well as support and logistics.

Overviews

SIMATIC NET

Introduction

Overview

SIMATIC NET

Industrial communication – the backbone of automation

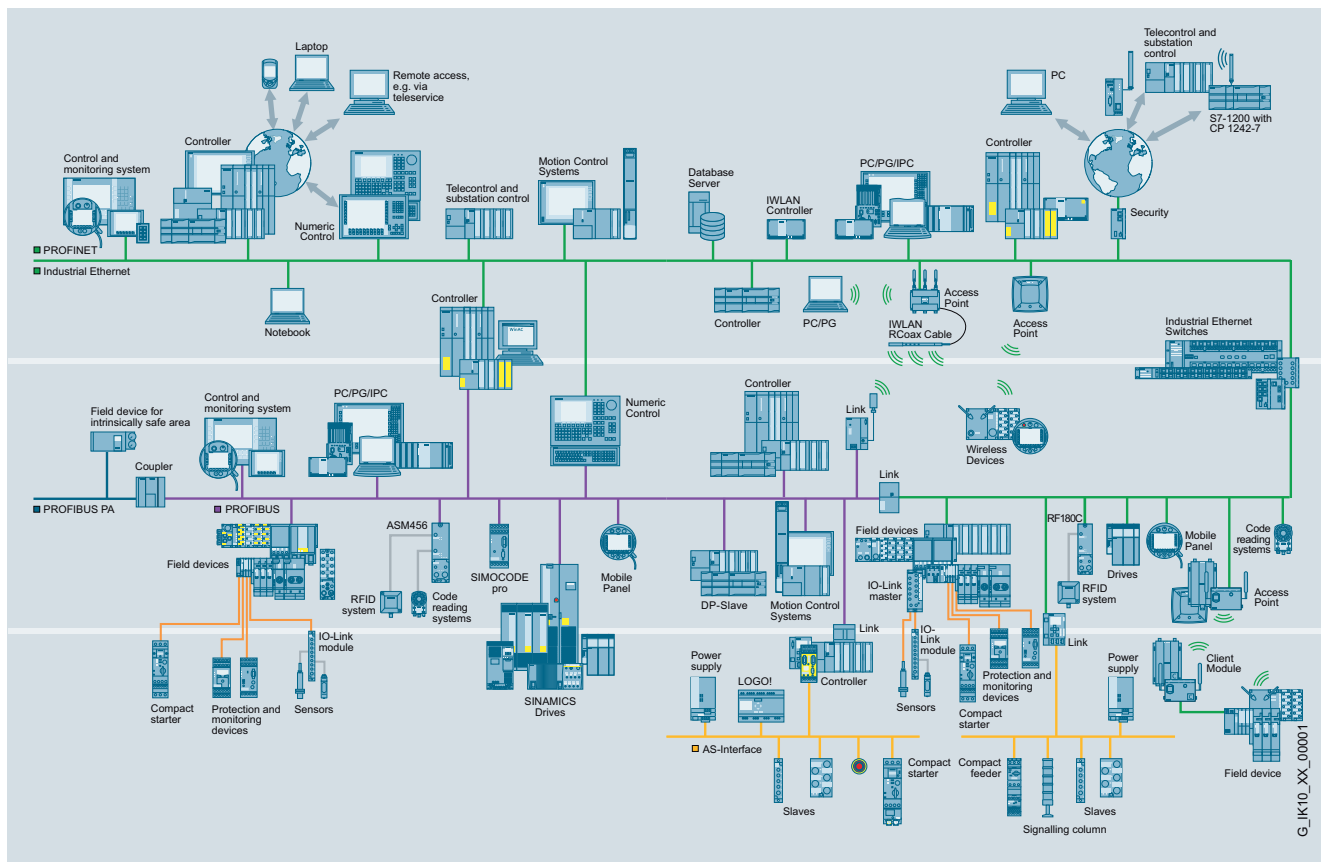

Powerful and open communication systems ensure trouble-free communication for automation systems, covering

- data communication or
- process or field communication.

Openness and flexibility of the individual communication systems in different topologies enable linking of a wide variety of systems and their subsequent expansions. By using standardized communication systems, it is possible to connect standardized components from different suppliers without any problems. This ensures maximum protection of investment, as existing networks can be extended without any adverse effects.

SIMATIC NET provides components for an integrated overall solution beyond network boundaries.

These include:

- Passive network components, e.g. FastConnect cabling systems
- Active network components, e.g. SCALANCE X Industrial Ethernet switches
- Interfaces for connecting programmable controllers to the communication systems:
 - Integrated interfaces
 - Communications processors
- Components for wireless networks, e.g. Industrial Wireless LAN, SCALANCE W Access Points, and Client Modules
- Components for industrial security
- Components for Industrial Remote Communication, worldwide access to outlying plants, distant machines, and for mobile applications such as TeleControl.
- Components for the connection to remote networks, e.g. SCALANCE M
- Routers, e.g. IE/PB Link PN IO
- Software for configuration, monitoring and diagnosis of the network, e.g. SINEMA Server

More information

- Catalog IK PI
- Catalog CA 01 on DVD
- Internet: www.siemens.com/industrial-communication

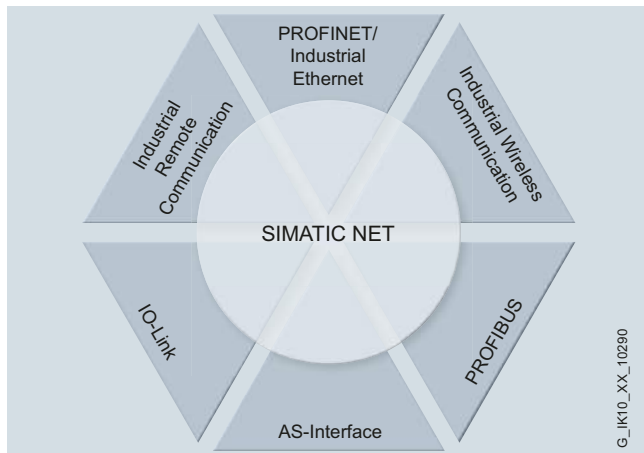

Overview

SIMATIC Ident – for more cost-effective production and logistics processes

Fiercer competition, stricter standards and legal regulations, shorter product lifecycles, more individual customer requirements, and the increasing globalization of the value-added chain: to stay ahead in ever more dynamic markets, companies must increase the efficiency of their value-added chain. And this applies to production control, asset management, tracking & tracing, as well as supply chain management. Through the use of innovative identification technology, companies can gain an important competitive edge.

But should RFID or optical code reading systems be used? Which technology is the right one for the respective application? Is an alternative or joint application appropriate, and how flexibly can you react to changing requirements? Siemens can help you to make the right decision. We offer SIMATIC Ident, a unique portfolio for industrial identification which can provide the perfect solution for your requirements while keeping your options flexible for the future.

The two technologies constitute a single system

The appropriate identification technology depends on factors such as recording distance, light conditions, single or repeated identification, and environmental influences such as temperature and contamination. Depending on the application, optical and RFID systems can also be used together as a hybrid solution in the same production line, e.g. DMC for direct marking on the product and RFID for pallets or workpiece holders.

In this case, seamless connection of the two technologies is essential. Our SIMATIC Ident portfolios can offer you the appropriate solution: using joint communication modules or function blocks, connection of optical and RFID systems to the SIMATIC PLC is simple. This ensures an integrated software architecture for you and saves considerable time and money on engineering, commissioning and maintenance.

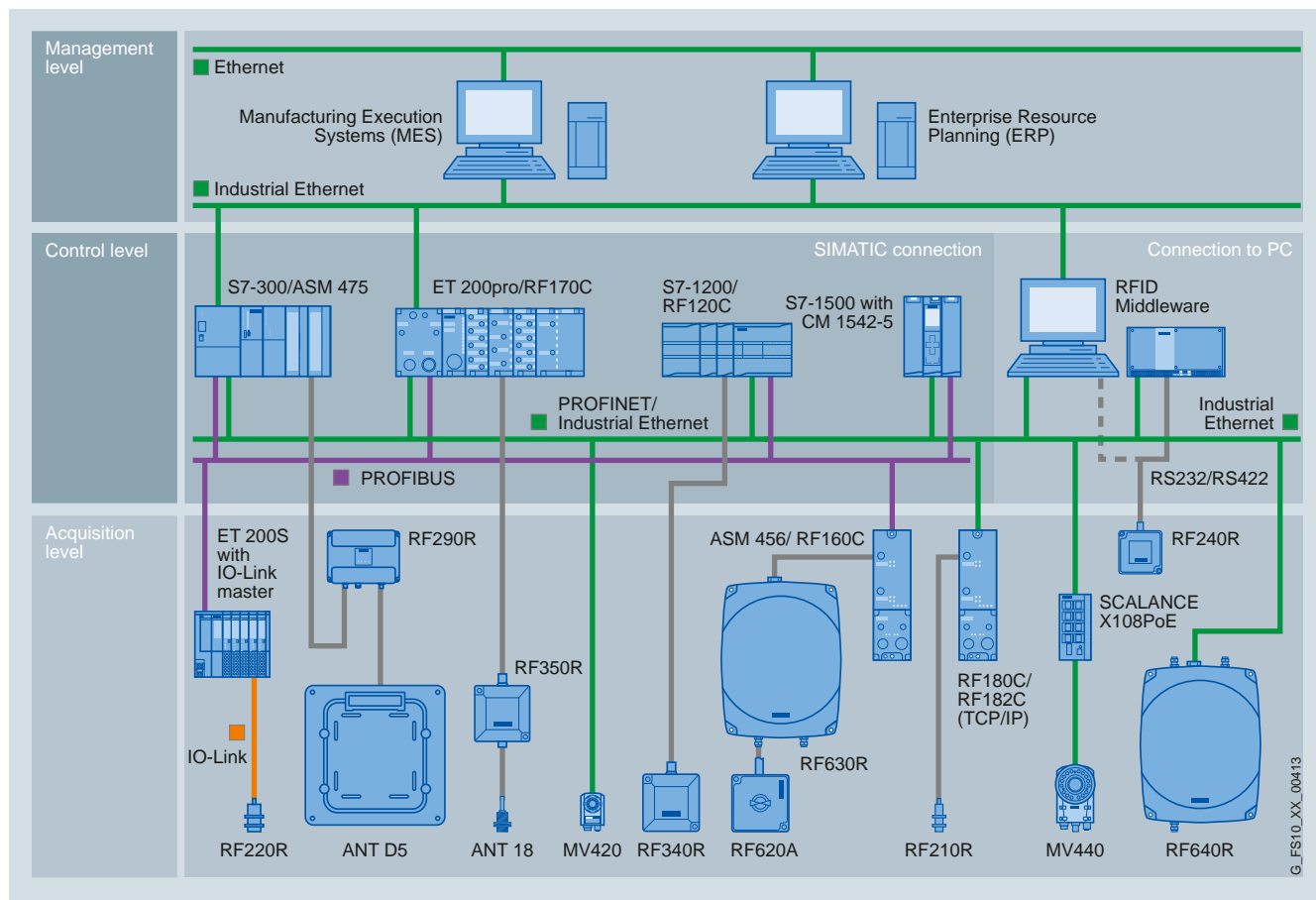

Overviews

SIMATIC Ident

Introduction

Overview (continued)

Identification systems: RFID and optical codes

Whether barcode, DMC, RFID or OCR: each technology has its specific strengths. Optical character recognition, for example, is used wherever information must also be read by people, such as the use-by dates on food products. 2D codes and RFID are renowned for their high level of data security and have proven their worth, even in the toughest industrial environments.

The decisive criterion for an identification system: your individual application.

Verification, identification: code reading systems



If increased performance is required, 2D codes are recommended as an alternative to a barcode, since they offer a higher storage capacity and a better read rate. They can be applied cheaply to products, e.g. together with dispatch labels. In addition, they enable direct part marking (DPM) of the products by means of lasers, printing or pinning, making them especially good at withstanding external influences. The recording of 2D codes is absolutely reliable even from acute viewing angles or under poor lighting conditions.

Our SIMATIC code reading systems provide the ideal solution for reading and verification of 1D and 2D codes and for optical character recognition (OCR), ensuring reliable traceability of production batches beyond the production plant.

Identification, mobile data storage:



If a line of sight does not exist between the recording unit and the code, if large data quantities or long distances are necessary, or if saved information has to be changed, this is a job for RFID. With this technology, the product or object is fitted with a memory chip that can be programmed and read wirelessly. With low-cost smart labels for the logistics, robust data memories for assembly lines and long-range transponders, RFID is ideal for a wide variety of applications.

Our intelligent SIMATIC RF system family offers you transparency without gaps. This makes data available at all times along the complete production and distribution route - thus allowing perfect control and optimization of material flows and logistics.

More information

- Catalog ID 10
- Catalog CA 01 on DVD
- Internet: www.siemens.com/simatic-ident

Supplementary components



14/2 14/2	Drive systems SINAMICS
14/6 14/6	Overvoltage protection SICROWBAR overvoltage protection
14/7 14/7	Timing, coupling and monitoring relays SIRIUS relays
14/9	Measuring systems
14/9 14/9 14/10	Automation systems SIMOTION Motion Control System SINUMERIK CNC automation systems
14/12 14/12	Time synchronization SICLOCK
14/13 14/13	System cabling MOTION-CONNECT connection systems

Supplementary components

Drive systems

SINAMICS

Overview



The SINAMICS family

- Uniform range of drives for every application and sector.
- Wide output range from 0.12 kW up to 120 MW.
- Wide range of functions from simple V/f control up to highly dynamic servo control.
- Designed for trouble-free interaction with other automation components from Siemens.
- Joint platform concept with uniform functionality, configuration, commissioning and operation as well as a standardized diagnostics concept and consistent communication mechanisms.

SINAMICS V20 – the versatile converter for basic applications



- Performance range: 0.12 – 15 kW
- Voltage:
1AC 230 V: 1AC 200 V ... 240 V (-10% ... +10%)
3AC 400 V: 3AC 380 V ... 480 V (-15% ... +10%)
- Can be arranged side by side to save space for wall or through-hole mounting.
- Integrated USS and Modbus RTU interfaces.
- Read out and clone parameters without voltage supply.
- Integrated connection and application macros.
- Energy-saving ECO mode for V/f and V²/f control.
- Integrated hibernation mode in idle state.

More information

- Internet:
www.siemens.com/sinamics-v20

SINAMICS G110D – the distributed single drive for simple solutions



- Stepless speed control for three-phase asynchronous motors
- Meets all of the requirements of conveying applications with frequency control
- Distributed layout – ideal for applications which cover large areas
- Integrated into TIA via AS-interface
- Wide output range from 0.75 to 7.5 kW

More information

- Catalog D 31
- Internet:
www.siemens.com/sinamics-g110d

SINAMICS G120P – the specialist for pumps, fans, and compressors



- SB interface, IOP operating unit
- Energy-efficient due to minimal apparent power loss, automatic adjustment of the motor current to the current load conditions with ECO mode
- Automatic switchover to mains operation at rated speed
- Hibernation (sleep mode) depending on the setpoint value, auto-ramping function for current limiting
- Communication: RS485, USS, Modbus RTU, BACnet MS/TP, PROFINET, PROFIBUS DP, CANopen

More information

- Catalog D 31
- Internet:
www.siemens.com/sinamics-g120p

Overview (continued)

SINAMICS G120D – the distributed single drive for high-performance solutions



- Positioning capability
- Performance range from 0.75 – 7.5 kW
- Energy-efficient thanks to regenerative feedback and minimal circuit feedback
- Safety Integrated: STO, SS1, SDI, SSM and SLS without encoder
- Thanks to modularity, minimal stocks of electronics have to be kept
- Replaceable MMC/SD memory card
- Communication via PROFIBUS DP, PROFINET, PROFIsafe
- Integrated in Totally Integrated Automation

More information

- Catalog D 31
- Internet:
www.siemens.com/sinamics-g120d

SINAMICS G120 C – the compact single drive with low output and matching functionality



- Compact unit
- Maximum power density in its class
- Performance range: 0.55 kW – 18.5 kW
- Easy commissioning and maintenance
- With operating unit BOP-2 or IOP
- Safety Integrated: STO
- Communication options: PROFIBUS DP, CANopen, USS, Modbus RTU, PROFINET

More information

- Catalog D 31
- Internet:
www.siemens.com/sinamics-g120c

SINAMICS G120 – the modular single drive for low to medium outputs



- Performance range: 0.37 – 250 kW
- Safety Integrated: STO, SS1, SLS, SDI and SSM certified in accordance with EN 954-1 Category 3 and IEC 61508 SIL 2, as well as ISO 13849-1 PL d.
- Communication via PROFIBUS, PROFINET, RS485, USS, Modbus RTU, CANopen, BACnet MS/TP
- Energy-efficient thanks to regenerative feedback and minimal circuit feedback
- Parameter copying function for series commissioning

More information

- Catalog D 31
- Internet:
www.siemens.com/sinamics-g120

Supplementary components

Drive systems

SINAMICS

Overview (continued)

SINAMICS G130 / SINAMICS G150 –
the universal frequency converters for single drives with a high output



- Available as standardized control cabinet or built-in module
- Easy to service, thanks to readily accessible device modules
- Communication via PROFIBUS DP, PROFINET, and other interfaces
- Energy-efficient due to variable-speed operation
- Safety Integrated
- 100% line voltage at motor without side effects
- If required, with integrated line harmonics filter and dV/dt filter

More information

- Catalog D 11
- Internet:
www.siemens.com/sinamics-g130
www.siemens.com/sinamics-g150

SINAMICS S110 –
the specialist for simple positioning tasks

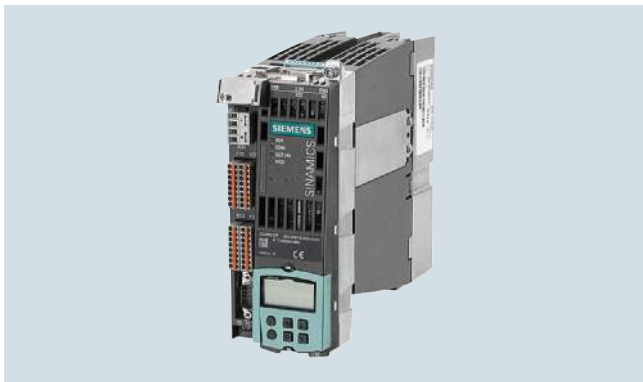

- Servo control
- Outputs of 0.12 ... 90 kW
- Safety Integrated
- Integrated positioning functions
- Straightforward system connection to higher-level controller (e.g. PLC) with PROFIBUS DP, PROFINET, CANopen

More information

- Catalog D 31
- Internet:
www.siemens.com/sinamics-s110

SINAMICS S120 –
The flexible, modular drive system for demanding single-axis and multi-axis applications from the lower to top performance ranges



- Specially for motion control and vector-regulated single-axis and multi-axis applications in all sectors of mechanical and plant engineering.
- Servo/vector regulation, V/f.
- Output range from 0.12 to 1200 kW, as cabinet modules up to 4500 kW
- Various designs with different focal applications.
- Highly flexible, e.g. as result of modular system architecture, different types of cooling, support for a wide range of motors/encoders, simple expandability.
- High degree of scalability with regard to performance, number of axes, functionality.
- Integrated safety functions.
- Comprehensive motion control functionality.
- High availability and efficiency even in unstable networks.
- Automatic parameterization and simple drive commissioning/optimization.

More information

- Catalogs PM 21, NC 61, NC 62, D 21.3
- Catalog CA 01
- Internet:
www.siemens.com/sinamics-s120
www.siemens.com/industrymall

Overview (continued)

SINAMICS S150 – The sophisticated drive solution for single drives in the medium to top performance ranges

- For applications with maximum demands on precision and dynamic response in the medium to top performance ranges such as test rig drives, elevator and crane systems, cross-cutters and shears, conveyor belts, presses, cable winders, and centrifuges.
- Ready-to-use control cabinet.
- Output range from 75 to 1200 kW.
- High availability and efficiency even in unstable networks.
- Efficient operation through standard energy recovery.
- Reactive power compensation possible.
- Equipped as standard with PROFIBUS DP interface for connection to higher-level controls.

More information

- Catalog D 21.3
- Internet:
www.siemens.com/sinamics-s150

SINAMICS GM150 – the universal drive solution for single drives in the medium-voltage range

- Single drive for applications with quadratic and constant load characteristic without regeneration.
- Space-saving, quick and easy commissioning.
- Ready-to-connect cabinet unit.
- Particularly suitable for economical use of pumps, fans, extruders, mixers, etc.
- Power unit with HV-IGBT technology for outputs up to 13 MVA, output voltage 2.3 to 4.16 kV, alternatively with air or water cooling.
- Power unit with IGCT technology for outputs from 10 MVA to 21 MVA, output voltage 3.3 kV, water cooling.
- Optimum interaction with SIMATIC.

More information

- Catalog D 12
- Internet:
www.siemens.com/sinamics-gm150

SINAMICS SM150 – the sophisticated drive solution for single and multi-motor drives in the medium-voltage range

- Single or multi-motor drives for regenerative, highly dynamic applications.
- Roller drives (cold, warm), hoisting drives, test rigs, belt systems.
- Power unit with HV-IGBT technology for outputs from 3.4 to 5.8 MVA, output voltage 3.3 and 4.16 kV, alternatively with air or water cooling.
- Power unit with IGCT technology for outputs from approx. 5 to 31.5 MVA, output voltage 3.3 kV, water cooling.
- Ideal for direct power exchange over the common DC bus with multi-motor drives with regenerative and motorized operation.
- Optimum interaction with SIMATIC.

More information

- Catalog D 12
- Internet:
www.siemens.com/sinamics-sm150

SINAMICS DCM – the scalable drive system for basic and sophisticated DC drive applications

- In the output range from 6 kW to 30 MW for industrial machines and plants (steel/aluminum, plastics, printing, paper, lifting gear, mining, oil & gas, excitation systems) in new plants and for retrofitting
- PROFIBUS DP as standard, PROFINET optional
- Control unit variance
- Field power supply in line with requirements
- Electronic power supply for connection to 24 V DC
- Power unit isolated with respect to ground (floating voltage detection)
- Free function blocks and Drive Control Chart (DCC)
- Expandable functionality using SINAMICS components
- Single-phase operation possible
- Coated modules and nickel-plated copper busbars
- Wide temperature range

More information

- Catalogs D 23.1, D 23.2
- Internet:
www.siemens.com/sinamics-dcm

Supplementary components

Overvoltage protection

SICROWBAR overvoltage protection

Overview

SICROWBAR AC overvoltage protection



SICROWBAR AC overvoltage protection is used to protect power semiconductors in converters (thyristors and diodes) against overvoltage that occurs between the phases of a three-phase network. The range of applications is not restricted to protecting DC drive converters, but also comprises infeed/regenerative feedback units of the AC drive technology that are equipped with thyristors.

Overvoltage that occurs on the AC side of converters is mainly caused by switching operations when disconnecting from the line supply at the transformer's primary side. This applies both to operational switching operations (shutdown at no-load) as well as in the case of a fault (shutdown under load).

The overvoltage protection is mainly used in the following configuration:

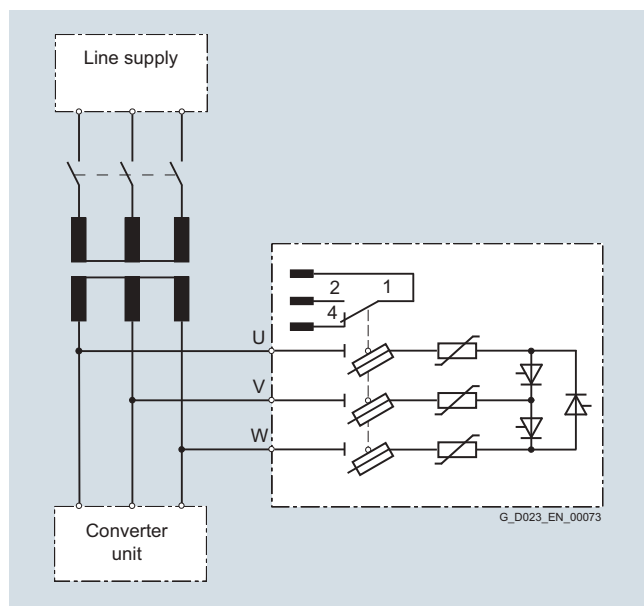

More information:

- Catalog D 23.1
- Internet:
www.siemens.com/sinamics-dcm

SICROWBAR DC overvoltage protection



SICROWBAR DC overvoltage protection protects coils and converters against overvoltage conditions when they are used to supply large inductances, for instance the excitation coils of synchronous machine motors, DC machine motors or hoisting solenoids.

As an option it is additionally possible to initiate high-speed de-excitation, triggered by a superimposed signal. A corresponding de-excitation/discharge resistor must be provided.

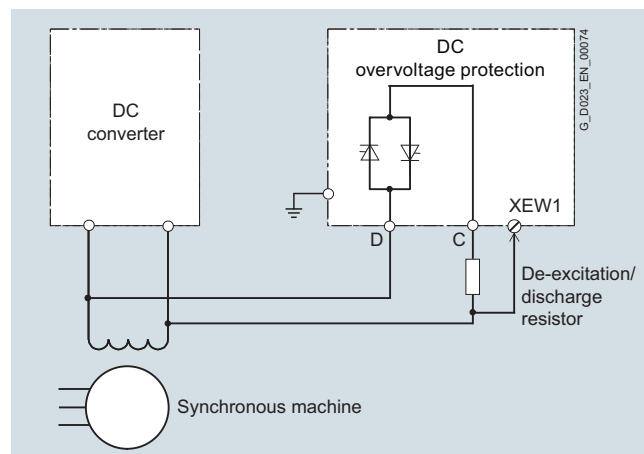

More information:

- Catalog D 23.1
- Internet:
www.siemens.com/sinamics-dcm

Overview



SIRIUS relays – one range for every application

Our range of SIRIUS relays offers you everything you need for a motor feeder application. Easy and convenient – and all from one source. Whether you require compact timing relays or reliable monitoring relays, particularly narrow coupling relays, plug-in relays, low-noise power relays or interface converters – it will not be easy to find a more complete and comprehensive range of relays anywhere. Quite simply, there is one for every possible need. What is more: all SIRIUS relays are particularly easy to use. So take a closer look at our range and convince yourself – you will be surprised.

SIRIUS 3UG, 3RR, 3RN, 3RS monitoring relays Reliable monitoring and protection

SIRIUS relays from Siemens offer maximum protection for machines and plants, and they now also communicate with the control level thanks to IO-Link. The new SIRIUS relays for IO-Link reliably monitor network quality, power values, voltages, speeds and temperatures and at the same time they open up an even wider field of applications for you.

3RS temperature monitoring relays operate autonomously or in parallel with a closed temperature control loop and serve to monitor a defined limit temperature in solid, liquid or gaseous media.

3UG monitoring relays are used to monitor electric and non-electric variables which cannot (or should not) be directly recorded by an automation system.

- Monitoring of networks for overvoltage or undervoltage, direction of rotation, or asymmetry.
- Monitoring of loads using Cos-phi or current measurement.
- Monitoring for insulation faults and fault currents.
- Monitoring of levels or speeds of rotation.

The 3RR current monitoring relays are suitable not only for monitoring motors or other loads, but are also well suited to monitoring multiphase currents of the entire plant or the driven process. In this way, for example, an idling pump or an overload is promptly detected and reported in good time. The 3RR2 monitoring relays can be set up individually or integrated directly into the load feeder.

3RN thermistor motor protection devices monitor the winding temperature of motors fitted with a PTC sensor.

- Compliance with the ATEX directive 94/9/EC through conformity with EN 60079-14 and EN 60947-8 standards.
- Fast fault diagnostics through display of open-circuit and short-circuit.
- Solid-state compatible output due to hard gold-plated contacts.

SIRIUS speaks IO-Link

With the SIRIUS monitoring relay for IO-Link you are opting for maximum flexibility: As well as the autonomous monitoring function that is still available, measured values and data can also be transferred directly to the controller via IO-Link. Parameters can also be assigned locally or via IO-Link. This means that the SIRIUS relays for IO-Link are fully integrated into Totally Integrated Automation, our open system architecture for integrated automation. You also profit from significantly simplified device replacement – thanks to data matching and automatic re-parameterization via a parameter server.

SIRIUS 3RP, 7PV timing relays

Electronic timing relays are used for all delayed switching operations in open-loop control, starting, protection and closed-loop control circuits.

Thanks to their sophisticated and compact design, the 3RP timing relays are ideal timer modules for control cabinet, switchgear and controller manufacturers from the industry. Due to their narrower design, the 7PV timing relays are particularly suitable for use in heating, ventilation and air-conditioning systems and compressors.

SIRIUS function modules and time-delayed auxiliary switches 3RA

The function modules permit the construction of starters and contactor combinations for direct and star-delta starting. They include the essential control functions that are needed for the respective feeder – e.g. timing and electrical interlocking functions. Function modules that function as timing relays can easily and quickly be fitted to SIRIUS contactors – without any significant wiring effort. They permit both ON-delay and OFF-delay switching on contactors.

The electronically delayed auxiliary switches that can be connected to contactors are designed for contactor coil voltages in the 24 to 240 V AC/DC range. Auxiliary switches for control and alarm signals are used specially for switching the smallest signals for electronics applications. They are used, for example, for allowing a pump or fan to run on, in a similar way to an OFF-delay relay or for the delayed activation of a gate drive. Simply by snapping and locking it into place, both the electrical and mechanical connection is made. To attenuate switching overvoltages of the contactor coil, a varistor is integrated in the time-delayed auxiliary switch.

Supplementary components

Timing, coupling and monitoring relays

SIRIUS relays

Overview (continued)

SIRIUS 3TX7, 3RS18, 3TG10 and LZS coupling relays

3TX7 coupling relays are available in two designs for making optimum use of space in the control cabinet. Firstly, the coupling relay with a width of just 6.2 mm, taking up the minimum of space on the DIN rail. Secondly, the low-profile coupling relay as a compact series, suitable for installation in a control cabinet with little space between rows, or in flatter control boxes.

The 3TX7 coupling relay is available in both conventional and semiconductor versions.

- Can be used for contact multiplication, adaptation of potential, or for EMC and overvoltage protection.
- Semiconductor versions for applications with high switching rate or for switching capacitive loads.
- Plug-in relays: At the end of its service life, a relay can be replaced without loosening the wiring.
- Wire inlet and connection screw are clearly accessible from the front.

The 3RS18 coupling relays set new standards: With a wide voltage range from 24 V to 240 V AC/DC they are the star attraction on the coupler market. In this series, we offer you devices in the field-proven 22.5 mm industrial enclosure with one, two or three changeover contacts – using screw-type or spring-type connections and for combination and wide-range voltage with hard gold-plated contacts for an especially high contact reliability – even at low current levels. Thanks to the well-proven industrial enclosure, you can enjoy the benefits of user-friendly connection systems with permanent wiring, just the same as with our timing relays. Two conductors can be connected at each terminal point.

3TG10 power relays prove their worth wherever small, low-noise relays or contactors are required at a reasonable price. This makes them ideal for simple controllers, especially for use in large-series manufactured devices and controllers. For applications that do not require an overload relay and need only one auxiliary switch – and which therefore need more switching power, higher switching voltage, and a longer service life.

LZS plug-in coupling relays are available as complete devices or as individual modules for self-assembly or spare parts requirements. This series is divided into three designs: RT, PT, and MT.

- Can be used for contact multiplication, adaptation of potential, or for switching small loads.
- Max. 4 changeover contacts in one device:
 - Wide-voltage versions with or without hard gold-plated contacts
 - with screw-type or push-in spring-loaded terminals

SIRIUS 3RS17 interface converter

3RS17 interface converters are used mainly for the electrical isolation and conversion of analog signals. Sensors/actuators and controllers usually have different power supply units and therefore require electrical isolation in the signal circuit. This is done either in the controller or by means of interface converters.

The conversion of one signal into another is required if e.g. a voltage signal has to be converted into a current signal for transmission over a longer distance, or if the output of a sensor and the input of a controller do not match.

A further application is presented by the implemented frequency outputs, where the input signal is converted to a proportional frequency. This means that analog signals can be processed with digital inputs.

This is important if a controller offers no possibility for an analog input or if all analog inputs are already occupied, e.g. in the case of retrofits.

More information:

- Catalog IC 10
- Product documentation for SIRIUS relays
- Internet: www.siemens.com/relays

Supplementary components

Measuring systems, automation systems

Measuring systems

Overview



- Measuring systems are encoders for recording distances, angles of rotation, and velocities.
- Can be used on machines in various sectors, e.g. production machines, manipulators, machine tools, and special machines.
- Can be connected to SIMATIC, SINAMICS, SINUMERIK, SIMOTION, SIMOVERT MASTERDRIVES and SIMODRIVE.

- Accessories available for measuring systems: couplings, mounting material, connectors, and completely pre-assembled signal cables.
- External encoders are available as incremental or absolute-value encoders.
- Incremental encoders:
 - Interfaces RS 422 (TTL), 1 V_{pp} and HTL.
 - Operating voltage 5 V DC or 10 V to 30 V DC.
- Absolute-value encoders:
 - All absolute-value encoders are available in singleturn and multiturn versions.
 - Interface SSI (synchronous serial interface) or connection for EnDat, PROFIBUS DP, PROFINET IO with RT/IRT and DRIVE-CLiQ.
 - Encoders with PROFIBUS DP support Class 1 ... 3 profiles as well as isochronous mode, internode communication, and application-specific supplementary functions. They are parameterizable.
 - Encoders with PROFINET IO support Class 1 ... 4 profiles.
- All measuring systems are available in synchro flange and supported flange joint versions. The absolute encoders are available in a hollow shaft version

More information:

- Catalogs NC 60, NC 61, NC 62, NC 82, PM 21, D 31
- Catalog CA 01
- Internet:
 - www.siemens.com/sensor-systems
 - www.siemens.com/industrymall

SIMOTION Motion Control System

Overview



SIMOTION system

- The SIMOTION system is primarily used for machines in which motion control with servo or hydraulic axes has priority. Main fields of application include packaging, printing and plastics machines, as well as the automation of machines in the textile, converter technology, timber, glass, ceramic, and stone industries.
- The system approach: amalgamation of motion control with logic and technology functions. In this case, all movements, logic functions at motion level, and technology functions such as temperature and hydraulic controls or cams, are executed in the same system.

- Benefits:
 - No time-critical interfaces between the components.
 - No programming requirements for these interfaces.
 - Uniform and transparent programming and diagnostics, as already known from PLC systems.
 - Free selection of hardware platform: Controller, PC or directly integrated in the drive.
 - Simple, graphic sequential programming using Motion Control Chart.
 - Integrated PLC functionality.
- Components of the SIMOTION system:
 - SCOUT engineering system:
 - The engineering system for complete automation of machines, including:
 - MCC (Motion Control Chart) for simple, graphic sequential programming;
 - LAD and FBD for programming of PLC tasks;
 - ST as text language for simple creation of functions and comprehensive calculations.
 - Runtime software modules:
 - Various motion control and technology functions for implementing simple axis positioning by means of synchronous operation and cam disks up to 3D path interpolation with transformations for various handling kinematics. Specific selection allows flexible adaptation of the system to the machine.

Supplementary components

Automation systems

SIMOTION Motion Control System

Overview (continued)

- Components of the SIMOTION system:
 - Hardware platforms:
 - Different platforms allow adaptation to the respective machine. Available for selection are the compact version direct in the drive, the modular version in S7-300 design, and the open version as a pure software solution on an industrial PC.

SIMOTION D – Compact and integrated in the drive

- The complete automation of machines with drive control, PLC, motion control, and technology functionalities in a compact unit in SINAMICS S120 design.
- Particularly fast response
- Versatile networking via PROFIBUS, PROFINET or Ethernet
- Scalable with several performance versions
- SIMOTION D is available in two designs:
 - As a single-axis SIMOTION D410-2 with multiple axis option (Blocksize design). The control units are available in the D410-2 DP and D410-2 DP/PN versions and are snapped onto the SINAMICS S120 PM340 power modules of the Blocksize design.
 - As a multiple axis system SIMOTION D4x5-2 in four performance variants for up to 128 axes (Booksize design).
- Ideally suited for:
 - Compact machines
 - Distributed automation concepts, e.g. for machines with multiple axes
 - Modular machines
 - Time-critical demands on axis couplings

SIMOTION C – Modularity and flexibility

- Controller in S7-300 design.
- Two versions, optionally with integrated drive interfaces for analog and stepper drives or with PROFINET interface.
- Onboard inputs/outputs expandable by I/O and function modules of the SIMATIC S7-300.
- With integrated isochronous PROFIBUS interfaces for distributed connection of drives or for communication with operator panels and higher-level controls.

- Ideally suited for:
 - Largest possible freedom in the choice of drives
 - Wide range of process signals
 - Retrofit applications through integral analog interfaces.

SIMOTION P – Open for other tasks

- PC-based, open motion control system available in two versions:
 - SIMOTION P320-3 for embedded PC solutions with the Windows Embedded Standard 2009 operating system
 - SIMOTION P350-3 for high-performance applications with the Windows XP operating system.
- Control, motion control, and HMI functions are executed together with standard PC applications on the same platform. User advantages:
 - Through utilization of the PC platform and the Microsoft Windows operating system – with a real-time expansion for SIMOTION – SIMOTION P combines the advantages of two worlds:
 - The openness of the Windows operating system
 - The real-time capability of the SIMOTION operating system
- Ideally suited for:
 - Applications requiring an open PC environment
 - Applications with particularly high-performance demands, e.g. hydraulic applications
 - Applications requiring control and visualization on one hardware platform
 - Comprehensive data storage, evaluation, and logging

More information:

- Catalog PM 21
- Catalog CA 01
- Internet:
 - www.siemens.com/simotion
 - www.siemens.com/industrymall

SINUMERIK CNC automation systems

Overview



SINUMERIK 840D with SIMODRIVE 611 digital

- The digital system for the toughest demands.
- For use in mold making and tool manufacture, for complex industrial scale manufacturing in the job shop, and for almost all technologies.
- With up to 10 CNC channels and 31 axes per NCU module. Thus also appropriate for use in the rotary indexing and cyclic machines sector (e.g. presses, packaging and printing machines).
- Scalable NCU software with 2/6/12/31 axes for several different NCU modules and correspondingly high CNC functionality.
- Coupling facility for up to 8 NCUs with max. 248 axes via NC link.

Overview (continued)

- Special technology functions (e.g. laser machining, handling) available using reloadable compile cycles. Optimum adaptation to the machines and the equipping of uniform machine series is thus possible.
- All NCUs with optional PROFIBUS DP interface (master/slave).

More information:

- Catalog NC 60
- Catalog CA 01
- Internet:
www.siemens.com/sinumerik
www.siemens.com/industrymall

SINUMERIK 828D BASIC T/BASIC M with SINAMICS S120 Combi



Compact, strong, straightforward – simply ingenious

The compact, operator-panel based SINUMERIK 828D BASIC T/BASIC M CNC controls offer maximum ruggedness and easy maintainability.

Powerful CNC functions coupled with a unique 80 bit NANO^{FP} accuracy result in maximum workpiece precision and minimum machining time. Thanks to a flexible CNC programming language and the exceptional ShopTurn/ShopMill machining step programming, both mass produced components and individual workpieces can be programmed and machined with the maximum possible efficiency. Pre-configured technology-specific system software and unique servicing functions reduce the costs for commissioning and servicing to an absolute minimum.

Tailored for standard turning machines ...

The SINUMERIK 828D BASIC T CNC control is perfectly tailored to the requirements of modern standard turning machines. With powerful kinematic transformers and a comprehensive selection of technology cycles, the SINUMERIK 828D BASIC T is also well-equipped for sophisticated machining with rotating tools.

Perfectly tailored and pre-configured for:

- Up to 5 axes/spindles in one machining channel
- Front side machining with rotating tools
- Lateral surface machining with rotating tools

... Standard milling machines

The SINUMERIK 828D BASIC M CNC control is perfectly tailored to the requirements of modern standard milling machines. With the integrated SINUMERIK MDynamics technology package including the new intelligent motion and velocity control Advanced Surface, the SINUMERIK 828D BASIC M is also well-equipped for the machining of mold making workpieces.

Perfectly tailored and pre-configured for:

- Up to 5 axes/spindles in one machining channel
- Lateral surface machining with A axis
- Machining and use in mold making

More information:

- Catalog NC 82
- Catalog CA 01
- Internet:
www.siemens.com/sinumerik
www.siemens.com/industrymall

SINUMERIK 840D sl



SINUMERIK 840D sl offers modularity, openness, flexibility and uniform structures for operation, programming, and visualization. It provides a system platform with trend-setting functions for almost all technologies.

Integrated into the SINAMICS S120 drive system and complemented by the SIMATIC S7-300 automation system, the SINUMERIK 840D sl forms a complete digital system that is optimally suited to the mid and upper performance range.

SINUMERIK 840D sl is characterized by:

- A high level of flexibility
- Maximum dynamics and precision
- Optimum integration into networks

Benefits

- Maximum performance and flexibility for medium to complex multi-axis systems, thanks to scalable hardware and software
- Consistent openness in the area of the user interface, the PLC, and the NC core for the integration of your specific know-how
- Integrated safety functions for man and machine: SINUMERIK Safety Integrated
- Comprehensive range of functions for the integration of machine tools into communication, engineering and production processes: SINUMERIK Integrate

Supplementary components

Automation systems, time synchronization

SINUMERIK CNC automation systems

Overview (continued)

Applications

The SINUMERIK 840D sl can be used globally in the following technologies:

- Turning
- Drilling
- Milling
- Grinding
- Laser cutting
- Nibbling
- Punching
- Toolmaking and moldmaking
- High-speed cutting applications
- Woodworking and glass processing
- Handling
- Transfer lines

- Rotary indexing machines
- Mass series production
- JobShop production

For use in countries requiring approval, there is the export version SINUMERIK 840DE sl.

More information:

- Catalog NC 62
- Catalog CA 01
- Internet:
 - www.siemens.com/sinumerik
 - www.siemens.com/industrymall

SICLOCK

Overview

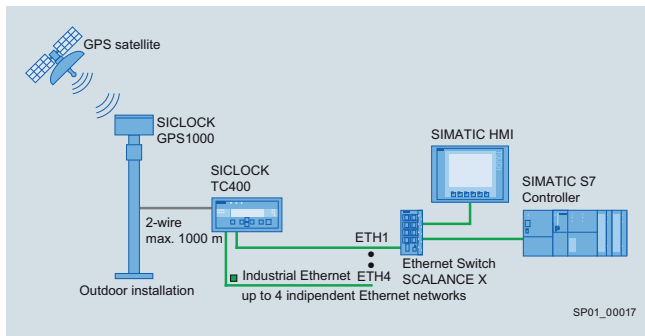

A time synchronization system typically consists of four elements:

- Time sources (e.g. GPS satellite)
- Wireless receivers
- Central plant clock
- The system to be synchronized

The Siclock series of products offers a wide range of wireless receivers, central plant clocks, pulse converters, and accessories for constructing reliable, low-maintenance time synchronization systems.

All Siclock components are designed for shared use with SIMATIC S7, SIMATIC NET, PCS7, and WinCC.

Function principle

The Siclock wireless receivers use GPS satellites or the DCF77 time signal transmitter as their time source and transmit time information via a 2-wire cable to the Siclock TC100/TC400 central plant clock.

The central plant clock converts this information into special Ethernet data packets (e.g. NTP) and makes it available to all nodes present in the network. The quartz oscillator integrated into the central plant clock ensures a reliable and smooth synchronization of the plant in the event of a break in reception or a fault in the time source.

More information:

- Email: siclock@siemens.com
- Internet:
 - www.siclock.com
 - www.siclock.de

In automation systems, the synchronization of industrial plants of any size is playing an increasingly important role. Only if all network nodes are synchronized cyclically from a central location with a reliable time frame can the optimum processing sequence be guaranteed.

Overview



MOTION-CONNECT cables are suitable for use with many different types of machine tools and production machinery.

The following variants of MOTION-CONNECT cable are available as fully-assembled power and signal cables or sold by the meter:

- MOTION-CONNECT 500
 - Cost-effective solution for predominantly fixed installation
 - Suitable for low mechanical loading
 - Tested for travel distances of up to 5 m
- MOTION-CONNECT 800PLUS
 - Meets requirements for use in cable carriers
 - Suitable for high mechanical loading
 - Oil resistance
 - Tested for travel distances of up to 50 m

Benefits

Pre-assembled MOTION-CONNECT cables provide high quality and perfect, system-tested functionality.

SPEED-CONNECT

Fast, stable and reliable connections can be made with the new, pre-assembled cables with SPEED-CONNECT connectors. With a short rotation as far as the stop, the cap nut of the connector secures the connection.

The cables with SPEED-CONNECT connectors supplement the previous offering of MOTION-CONNECT cables with fully-threaded connectors.

Applications

MOTION-CONNECT cables are intended for use in machines. They are not suitable for building technology applications or outdoor installation.

MOTION-CONNECT cables are tested in a cable carrier with horizontal travel distance and are also designed for cable carrier installation. They are not self-supporting.

The pre-assembled cables can be ordered in length units of 10 cm and can be extended, if necessary.

When cable lengths (basic cables and extensions) are determined for the systems and applications described in this catalog, the technically permissible maximum cable lengths (e.g. 25 m) specified in the catalog must be observed. Malfunctions can occur if longer cables are used.

Siemens AG assumes no liability for correct transmission of signals or power in this case.

Compatibility between SPEED-CONNECT and full-thread connectors:

Connector on motor with external thread	Connector with cap nut on cable	Compatibility
SPEED-CONNECT	SPEED-CONNECT	✓
SPEED-CONNECT	Full thread	✓
Full thread	Full thread	✓
Full thread	SPEED-CONNECT	-

More information:

- Catalogs NC 60, NC 61, NC 62, NC 82, PM 21, D 31
- Catalog CA 01
- Internet:
 - www.siemens.com/industrymall
 - www.siemens.com/motion-connect

Supplementary components

Notes

Appendix



15/2	Siemens Industry Training
15/3	Additional documentation
15/3	Specialist books for automation engineering
15/5	SIMATIC Manual Collection
15/6	Standards and approbations
15/6	CE marking
15/7	Certificates
15/7	Quality management
15/8	Partners at Industry Automation and Drive Technologies
15/8	Siemens contacts worldwide
15/9	Siemens Solution Partner Automation
15/10	Siemens Automation Cooperates with Education
15/10	Applicable practical know-how
15/12	Online Services
15/12	Information and Ordering in the Internet and on DVD
15/13	Information and Download Center, Social Media, Mobile Media
15/14	Industry Services
15/14	Your machines and plant can do more – with Industry Services.
15/15	Industry Services for the entire life cycle
15/19	Software Licenses
15/21	Index
15/25	Order No. index
15/29	Catalog improvement suggestions
15/32	Conditions of sale and delivery

Appendix

Siemens Industry Training

Faster and more applicable know-how: Hands-on training from the manufacturer

Siemens Industry Training provides you with comprehensive support in solving your tasks.

Training by the market leader in the industry enables you to make independent decisions with confidence. Especially where the optimum and efficient use of products and plants are concerned. You can eliminate deficiencies in existing plants, and exclude expensive faulty planning right from the beginning.



First-class know-how directly pays for itself: In shorter startup times, high-quality end products, faster troubleshooting and reduced downtimes. In other words, increased profits and lower costs.

Achieve more with Siemens Industry Training

- Shorter times for startup, maintenance and servicing
- Optimized production operations
- Reliable configuration and startup
- Minimization of plant downtimes
- Flexible plant adaptation to market requirements
- Compliance with quality standards in production
- Increased employee satisfaction and motivation
- Shorter familiarization times following changes in technology and staff

Contact

Visit our site on the Internet at:

www.siemens.com/sitrain

or let us advise you personally.

Siemens Industry Training Customer Support Germany:

Phone: +49 (911) 895-7575

Fax: +49 (911) 895-7576

E-Mail: info@sitrain.com

Highlights Siemens Industry Training

Top trainers

Our trainers are skilled teachers with direct practical experience. Course developers have close contact with product development, and directly pass on their knowledge to the trainers.

Practical experience

The practical experience of our trainers enables them to teach theory effectively. But since theory can be pretty drab, we attach great importance to practical exercises which can comprise up to half of the course time. You can therefore immediately implement your new knowledge in practice. We train you on state-of-the-art methodically/didactically designed training equipment. This training approach will give you all the confidence you need.

Wide variety

With a total of about 300 local attendance courses, we train the complete range of Siemens Industry products as well as interaction of the products in systems.

Tailor-made training

We are only a short distance away. You can find us at more than 50 locations in Germany, and in 62 countries worldwide. You wish to have individual training instead of one of our 300 courses? Our solution: We will provide a program tailored exactly to your personal requirements. Training can be carried out in our Training Centers or at your company.

The right mixture: Blended learning

"Blended learning" is a combination of various training media and sequences. For example, a local attendance course in a Training Center can be optimally supplemented by a teach-yourself program as preparation or follow-up. Additional effect: Reduced traveling costs and periods of absence.



Overview

Siemens specialist books provide you with a profound knowledge of the various fields of automation engineering. They help readers at various levels, from beginners to experts, to familiarize themselves with individual topics, to consolidate their knowledge and they act as reference manuals.

Ordering data	Order No.	Order No.
<p>Automation with SIMATIC</p> <p>The book is perfectly suited for all those with little advance experience and who wish to familiarize themselves quickly with the field of programmable controllers.</p> <p>German</p> <p>English</p>	<p>6ZB3 500-0AE01-0AA0</p> <p>6ZB3 500-0AE02-0AA0</p>	<p>Automating with SIMATIC S7-300 inside TIA Portal</p> <p>STEP 7 Professional V11 engineering software</p> <p>In this book you can find a comprehensive description of the configuration of devices and network for the S7-300 components inside the TIA Portal engineering framework. You learn how a control program is formulated and tested with the graphical programming languages LAD and FBD, as well as with the text-based programming languages STL and SCL. You are then introduced to configuring the distributed I/O with PROFIBUS DP and PROFINET IO using SIMATIC S7-300 and data exchange via Industrial Ethernet.</p> <p>German</p> <p>English</p>
<p>Automating with SIMATIC S7-1200</p> <p>The book introduces the hardware components of the S7-1200 automation system and describes their configuration and parameterization. A sound introduction to STEP 7 Basic V11 illustrates the fundamentals of programming and troubleshooting. Beginners learn the fundamentals of automation engineering with SIMATIC S7-1200, and those changing from S7-200 and S7-300 can find the knowledge required for this.</p> <p>German</p> <p>English</p>	<p>6ZB3 500-0BK01-0AA0</p> <p>6ZB3 500-0BL01-0AA0</p>	<p>Automating with SIMATIC S7-400 in the TIA Portal</p> <p>Configuration, programming and testing with STEP 7 Professional V11</p> <p>This book describes device and network configuration for the S7-400 components with the TIA Portal user interface. You learn how a control program is formulated and tested with the graphical programming languages LAD and FBD, as well as with the text-based programming languages STL and SCL. You are then introduced to configuring the distributed I/O with PROFIBUS DP and PROFINET IO using SIMATIC S7-400 and data exchange via Industrial Ethernet.</p> <p>German</p> <p>English</p>
<p>Automating with SIMATIC S7-1500</p> <p>With its numerous innovations, SIMATIC S7-1500 sets new standards in terms of performance and productivity in control engineering. With its unique system performance and PROFINET as the standard interface, the new controller guarantees short system response times and the highest quality control with maximum flexibility for the most demanding automation tasks. The book presents the new automation system in detail. You will learn how the standardized operating concept for controller, HMI and drives is implemented in the TIA portal with standardized data storage and how to exploit the advantages of the TIA portal efficiently.</p> <p>German</p> <p>English</p>	<p>6ZB3 500-0BS01-0AA0</p> <p>6ZB3 500-0BT01-0AA0</p>	<p>Automating with SIMATIC S7-400 in the TIA Portal</p> <p>Configuration, programming and testing with STEP 7 Professional V11</p> <p>This book describes device and network configuration for the S7-400 components with the TIA Portal user interface. You learn how a control program is formulated and tested with the graphical programming languages LAD and FBD, as well as with the text-based programming languages STL and SCL. You are then introduced to configuring the distributed I/O with PROFIBUS DP and PROFINET IO using SIMATIC S7-400 and data exchange via Industrial Ethernet.</p> <p>German</p> <p>English</p>
		<p>Automating with STEP 7 in STL and SCL</p> <p>The 7th Edition presents the STEP 7 engineering software (basic software) in the latest version of the service packs. It explains elements and applications of the text-oriented programming languages STL (Statement List) and SCL (Structured Control Language) for both SIMATIC S7-300 and SIMATIC S7-400, including new products for distributed I/O and for applications with Profinet and communication via Industrial Ethernet.</p> <p>German</p> <p>English</p>
		<p>6ZB3 500-0BM01-0AA0</p> <p>6ZB3 500-0BN01-0AA0</p> <p>6ZB3 500-0BP01-0AA0</p> <p>6ZB3 500-0BQ01-0AA0</p> <p>6ZB3 500-0AA01-0AA0</p> <p>6ZB3 500-0AA02-0AA0</p>

Appendix

Additional documentation

Specialist books for automation engineering

Ordering data	Order No.		Order No.
<p>Automation with STEP 7 in LAD and FBD</p> <p>Ladder diagram (LAD) and function block diagram (FBD) use graphic symbols for representing the control functions – similar to those in wiring diagrams or electronic circuits. The sixth edition of this book describes these graphic-oriented programming languages in conjunction with the STEP 7 V5.5 engineering software for the SIMATIC S7-300 and S7-400 automation systems. New functions of this STEP 7 version concern, in particular, the CPU web server and PROFINET IO, such as the application of I-devices, shared devices and isochronous mode.</p> <p>German</p> <p>English</p>	<p>6ZB3 500-0AB01-0AA0</p> <p>6ZB3 500-0AB02-0AA0</p>	<p>Fundamentals of Motion Control</p> <p>The book "Fundamentals of Motion Control" is intended for apprentices or students of engineering sciences as well as for anyone seeking basic information on motion control and the associated topics. The fundamentals of motion control are explained in a practice-oriented, easy to understand way.</p> <p>English</p>	<p>6ZB3 500-0BR01-0AA0</p>
<p>Controlling with SIMATIC</p> <p>This book describes control engineering in practical terms as a subset of open-loop control and automation engineering based on the SIMATIC S7 control system or the SIMATIC PCS 7 process control system within the scope of Totally Integrated Automation (TIA).</p> <p>German</p> <p>English</p>	<p>6ZB3 500-0AD01-0AA0</p> <p>6ZB3 500-0AD02-0AA0</p>	<p>Electrical drive technology</p> <p>This book deals with all aspects of modern electrical drive systems from a user viewpoint. It is aimed on the one hand at industrial users who want to understand, plan, use and maintain electrical drives and on the other hand at skilled operators, technicians, engineers and students who would like to acquire a comprehensive overview of electrical drive technology.</p> <p>German</p>	<p>6ZB3 500-0BD01-0AA0</p>
<p>Automating with PROFINET</p> <p>This book provides an introduction to the new PROFINET technology. Decision-makers, system designers and students get a compact overview of the concept, fundamentals, and current devices. Project engineers, start-up engineers and technicians obtain extensive knowledge that enables them to plan and solve their own PROFINET-based automation applications.</p> <p>deutsch</p> <p>englisch</p>	<p>6ZB3 500-0AP01-0AA0</p> <p>6ZB3 500-0AP02-0AA0</p>	<p>Industrial Ethernet in industrial automation</p> <p>This book provides plant planners and operators, programmers and commissioning engineers with the fundamental information and terminology for using Ethernet LAN technologies in industrial automation with SIMATIC.</p> <p>German</p>	<p>6ZB3 500-0AM01-0AA0</p>
		<p>Dictionary of electrical engineering, power engineering and automation</p> <p>This dictionary is a standard reference work for translators, engineers and technical writers who need a comprehensive and reliable collection of technical terms from the areas of power generation, transmission and distribution as well as drive and automation engineering, electrical installation engineering, power electronics, and measuring and test engineering.</p> <p>German-English</p> <p>English-German</p> <p>German-English/English-German, on CD-ROM</p>	<p>6ZB3 500-0AJ01-0AA0</p> <p>6ZB3 500-0AJ02-0AA0</p> <p>6ZB3 500-0AJ03-0AA0</p>

SIMATIC Manual Collection

Overview

The SIMATIC manual collection brings together the manuals of Totally Integrated Automation in the smallest possible package. It is eminently suitable for startup and service, replaces the space-consuming paper version in the office and provides fast access to the information.

The manual collection contains manuals in 5 languages for

- LOGO!
- SIMADYN
- SIMATIC bus components
- SIMATIC C7
- SIMATIC Distributed I/O
- SIMATIC HMI
- SIMATIC Sensors
- SIMATIC NET
- SIMATIC PC Based Automation
- SIMATIC PCS 7
- SIMATIC PG/PC
- SIMATIC S7
- SIMATIC Software
- SIMATIC TDC

Manuals that are not yet available in all 5 languages will at least be included in English and German.

There is an update contract for the SIMATIC Manual Collection that encompasses supply of the up-to-date collection and three subsequent updates which is valid for one year. If the update contract is not cancelled, it is automatically extended and the list price will be charged to the customer.

Ordering data	Order No.
SIMATIC Manual Collection Electronic manuals on DVD, multilingual: LOGO!, SIMADYN, SIMATIC Bus components, SIMATIC C7, SIMATIC Distributed IO, SIMATIC HMI, SIMATIC Sensors, SIMATIC NET, SIMATIC PC Based Automation, SIMATIC PCS 7, SIMATIC PG/PC, SIMATIC S7, SIMATIC Software, SIMATIC TDC	6ES7 998-8XC01-8YE0
SIMATIC Manual Collection update service for 1 year Current "Manual Collection" DVD and the three subsequent updates	6ES7 998-8XC01-8YE2

Appendix

Standards and approbations

CE marking

Overview

The electronic products described in this catalog comply with the requirements and protection objectives of the following EC directives insofar as they relate to the product concerned. They also comply with the corresponding harmonized European standards (EN) published for these products in the Official Journals of the European Community.

- Directive 2004/108/EC of the European Parliament and Council on the approximation of the laws of the Member States relating to electromagnetic compatibility (EMC Directive)
- Directive 2006/95/EC of the European Parliament and of the Council on the harmonization of the laws of Member States relating to electrical equipment designed for use within certain voltage limits (Low Voltage Directive)
- Directive 94/9/EC of the European Parliament and the Council on approximation of the laws of the Member States concerning equipment and protective systems intended for use in potentially explosive atmospheres (ATEX Directive).
- Directive 1999/5/EC of the European Parliament and of the Council on radio equipment and telecommunications terminal equipment and the mutual recognition of their conformity (RTTE Directive)

The originals of the declarations of conformity are kept available by us for the responsible supervisory authorities.

Note on the EMC Directive:

In terms of their interference emissions, SIMATIC products are designed for industrial applications.

If individual products deviate from this specification, it is noted in the catalog with the products.

The installation instructions in the manuals must be adhered to when installing and operating the products described in this catalog. These contain, for example, important information on installation in cabinets and on the use of shielded cables.

Notes for machine manufacturers

The SIMATIC automation system is not a machine within the context of the EU machine guidelines. Therefore a declaration of conformity with regard to the EU machine directive 89/392/EEC or 2006/42/EU (new edition, applicable from end of 2009) may not be provided for SIMATIC.

The EU machine directive regulates the requirements placed on a machine or a part thereof. A machine is understood for the purposes of this guideline to be a combination of interconnected parts or mechanisms (see also EN 292-1, Paragraph 3.1).

SIMATIC is part of the electrical equipment of a machine, and must therefore be integrated into the evaluation of the complete machine by the machine manufacturer.

As electrical equipment, SIMATIC is subject to the low-voltage directive which, as a "total safety directive", covers all dangers just like the machine directive.

The EN 60204-1 standard (safety of machines, general requirements for the electrical equipment of machines) is applicable to the electrical equipment of machines.

The following table will help you in the provision of your declaration of conformity, and shows which criteria according to EN 60204-1 (2006-06) apply to SIMATIC. You can obtain further information from the enclosed declaration of conformity according to the low-voltage and EMC directives (with list of included standards).

EN 60204-1	Topic/criterion	Notes
Paragraph 4	General requirements	The requirements are met when the equipment is assembled/installed in accordance with the installation guidelines. Please note the relevant information in the manuals.
Paragraph 11.2	Digital input/output interfaces	The requirements are met
Paragraph 12.3	Programmable equipment	The requirements are met when the equipment is installed in lockable cabinets to protect against alteration of the memory contents by unauthorized persons
Paragraph 20.4	Voltage tests	The requirements are met

Standards and approbations, quality management

Certificates, authorizations, approbations, declarations of conformity

An overview of the certificates available for SIMATIC products (CE, UL, CSA, FM, shipping authorizations) can be found in the internet at

www.siemens.com/simatic/certificates

The lists are continuously updated. The data for products which have not yet been included in the overview is continuously collected and prepared for the subsequent edition.

You can also find certificates, approbations, verification certificates or characteristic curves under Product support "Entry list"

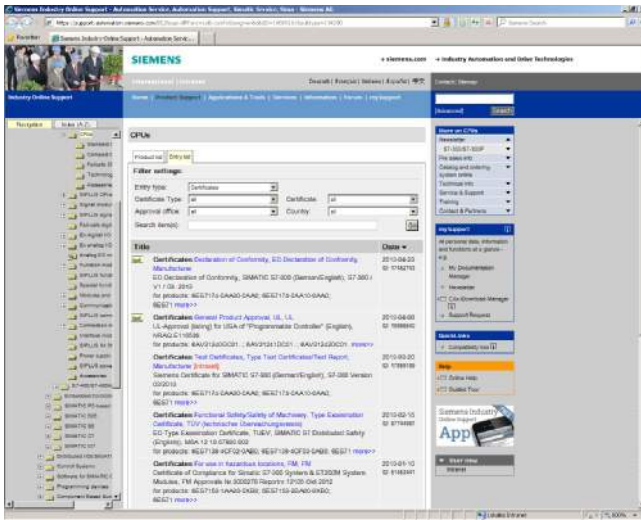

or by going directly to the Link Box:



Quality management

The quality management system of the Industry Sector, Industry Automation Division, complies with the international standard ISO 9001.

The products and systems described in this catalog are sold under application of a quality management system certified by DQS in accordance with DIN EN ISO 9001.

The DQS certificate is recognized in all EQ Net countries.

DQS Registered Certificate No.:

Siemens AG

- I IA AS Industrial Automation Systems
Reg. No.: 001323 QM08

Appendix

Partners at Industry Automation and Drive Technologies

Siemens contacts worldwide

Overview



At Siemens Industry Automation and Drive Technologies, more than 85 000 people are resolutely pursuing the same goal: long-term improvement of your competitive ability. We are committed to this goal. Thanks to our commitment, we continue to set new standards in automation and drive technology. In all industries – worldwide.

At your service locally, around the globe for consulting, sales, training, service, support, spare parts ... on the entire Industry Automation and Drive Technologies range.

Your personal contact can be found in our Contacts Database at: www.siemens.com/automation/partner

You start by selecting a

- Product group,
- Country,
- City,
- Service.

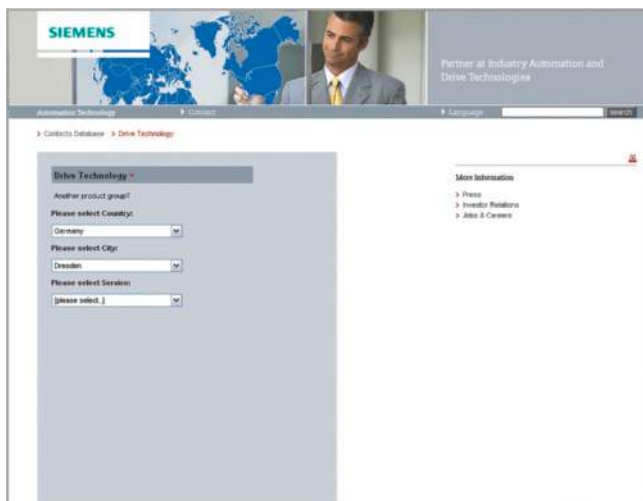

Overview

Siemens Solution Partner Automation

Solution Partner: Highest quality - guaranteed

The products and systems from Siemens Industry Automation and Drive Technologies offer the ideal platform for all automation applications.

Under the name of Siemens Solution Partner Automation, selected system integrators around the world act as uniformly qualified solution providers for the Siemens range of products and services in the fields of automation and drives. Day after day, they utilize their qualified product and system know-how as well as their excellent industry expertise to your advantage – for all requirements.

The partner emblem is the guarantee and indicator of proven quality. The basis for this are defined quality features that identify Solution Partners as reliable and competent solution providers:

- Solution quality
Always a good result with tried and tested solutions expertise.
- Expert quality
Certified technical competence ensures maximum efficiency.
- Project quality
With proven project experience straight to the target.
- Portfolio quality
Comprehensive portfolio for state-of-the-art solutions from a single source.

Solution Partner Finder

 The screenshot shows the Siemens Solution Partner Finder web interface. At the top, there's a navigation bar with 'Solution Partner', 'Language', and 'Contact'. Below that, the main heading is 'Solution Partner Finder'. The text asks if the user is looking for a qualified Solution Partner and provides instructions on how to use the search criteria. There are two tabs: 'Partner search' (selected) and 'References and Partner search'. The search form includes dropdown menus for Technology, Industry, Service (set to 'All'), Country (set to 'worldwide'), and Region (set to 'Please select a country first'). There is also a text input for 'Company/ZIP code' with a 'Search word' placeholder and a 'Zip code' input. A 'Find' button is at the bottom right. A note box on the right states: 'Note: Please note that the search criteria entered are linked with and.'

The Siemens Solution Partner Program helps you to find the optimum partner for your specific requirements.

Support is provided by the Solution Partner Finder, a comprehensive online platform that showcases the profiles of all our solution partners. You can convince yourself of the competence of the respective Solution Partner by means of the references provided. Various search criteria are available for this purpose.

Once you have located a partner, you are only one small step away from contacting them.

Find the right partner here for your specific task and convince yourself of the solution competence provided:

www.siemens.com/automation/partnerfinder

Additional information on the Siemens Solution Partner Program is available online at:

www.siemens.com/automation/solutionpartner

Appendix

Siemens Automation Cooperates with Education

Applicable practical know-how

Comprehensive teaching support for educational institutions

Cooperates
with Education

Automation

SIEMENS

Siemens Automation Cooperates with Education (SCE)

offers a global system for sustained support of technical skills. SCE supports educational institutions in their teaching assignment in the industrial automation sector and offers added value in the form of partnerships, technical expertise, and know-how. As the technological leader, our comprehensive range of services can support you in the knowledge transfer for Industry 4.0.

Our services at a glance

- Training curriculums for your lessons
- Trainer packages for hands-on learning
- Courses convey up-to-date, specialist knowledge
- Support for your projects/textbooks
- Complete didactic solutions from our partners
- Personal contact for individual support

Training curriculums for your lessons



Use our profound industrial know-how for practice-oriented and individual design of your course. We offer you more than 100 didactically prepared training curriculums on the topics of automation and drives technology free of charge. These materials are perfectly matched to your curricula and syllabuses, and optimally suited for use with our trainer packages. This takes into account all aspects of a modern industrial solution: installation, configuration, programming, and commissioning. All documents, including projects, can be individually matched to your specific requirements.

Particular highlights:

- With the new SIMATIC PCS 7 curriculums and trainer packages, you can pass on basic, practice-oriented PCS 7 knowledge at universities within about 60 hours (= 1 semester), using plant simulation.

- The new TIA Portal training materials for SIMATIC S7-1200 are available in English, German, French, Italian, Spanish and Chinese for download.

www.siemens.com/sce/documents

Trainer packages for hands-on learning



Our SCE trainer packages offer a specific combination of original industrial components which are perfectly matched to your requirements and can be conveniently used in your course. These price reduced bundles available exclusively to schools include innovative and flexible hardware and software packages. SCE can currently offer more than 90 SCE trainer packages including related equipment. These cover both the factory and process automation sectors. You can use them to impart the complete course contents on industrial automation at a very low cost.

Trainer packages are available for:

- Introduction to automation technology with LOGO! logic module and SIMATIC S7-1200 compact controller
- PLC engineering with SIMATIC S7 hardware and STEP 7 software (S7-300, S7-1500 and TIA Portal)
- Operator control and monitoring with SIMATIC HMI
- Industrial networking over bus systems with SIMATIC NET (PROFINET, PROFIBUS, IO-Link)
- Sensor systems with VISION, RFID and SIWAREX
- Process automation with SIMATIC PCS 7
- Power Monitoring Devices SENTRON PAC 4200
- Motor Management SIMOCODE
- Networked drive and motion technologies with SINAMICS/SIMOTION
- CNC programming with SinuTrain

Important ordering notes:

Only the following institutions are authorized to obtain trainer packages: vocational schools, Colleges and Universities, in-house vocational training departments, non commercial research institutions and non commercial training departments.

To purchase a trainer package, you require a specific end-use certificate, which you can obtain from your regional sales office.

www.siemens.com/sce/tp

Comprehensive teaching support for educational institutions (continued)

Courses convey up-to-date specialist knowledge

Profit from our excellent know-how as the leader in industrial technologies. We offer you specific courses for automation and drive technology worldwide. These support you in the practice-oriented transferring of product and system know-how, are in conformance with curriculums, and derived from the training fields. Compact technical courses especially for use at universities are also available.

Our range of courses comprises a wide variety of training modules based on the principle of Totally Integrated Automation (TIA). The focus is on the same subject areas as with the SCE trainer packages.

Every PLC and drive course is oriented on state-of-the-art technology. Your graduates can thus be prepared optimally for their future professional life.

In some countries we are offering classes based on our training curriculums. Please inquire with your SCE contact partner.

www.siemens.com/sce/contact

Support for your projects/textbooks

Automation and drive technology is characterized by continuous and rapid developments. Service and Support therefore play an important role.

We can provide you with consulting for selected projects and support from your personal SCE contact as well as our web based and regional Customer Support.

As a particular service, SCE supports technical authors with our know-how as well as with intensive technical consulting. Siemens library of special textbooks covering the industrial automation sector provides an additional resource for you and your students. These can be found at the SCE web site.

www.siemens.com/sce/contact
www.siemens.com/sce/books

Complete didactic solutions

Our partners for learning systems offer a wide range of training systems and solutions for use in your courses or laboratory.

These models have been designed based on our trainer packages and thus save you the time and cost of self-construction of individual components. The Partner systems provide you with simple and effective help in the fulfillment of your teaching assignment.

www.siemens.com/sce/partner

Contact for individual support

You can find your personal SCE contact on our Internet site. Your local SCE Promoter will answer all your questions concerning the complete SCE offering, and provide you with timely and competent information about innovations. When you encounter challenges, you can profit from our global team of excellence.

If a direct SCE contact is not listed for your country, please contact your local Siemens office.

www.siemens.com/sce/contact

SCE Support Finder for your Internet request

You are an educator and need support on the topic of industry automation? Send us your request:

www.siemens.com/sce/supportfinder

Scan the QR
code for further
information
(SCE homepage)



Appendix Online Services

Information and Ordering in the Internet and on DVD

Siemens Industry Automation and Drive Technologies in the WWW

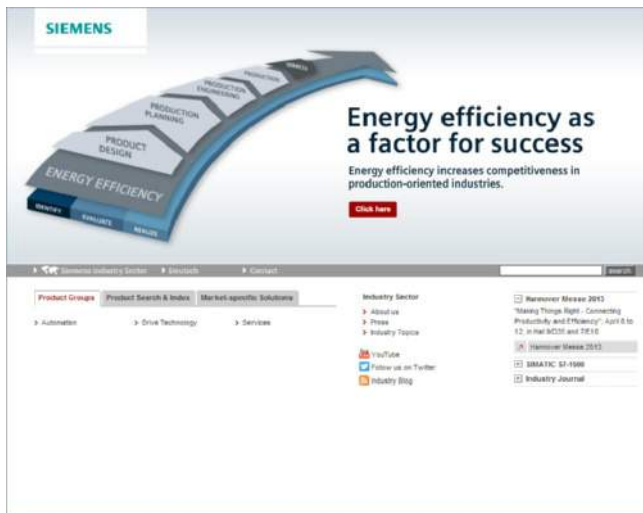

A detailed knowledge of the range of products and services available is essential when planning and configuring automation systems. It goes without saying that this information must always be fully up-to-date.

Siemens Industry Automation and Drive Technologies has therefore built up a comprehensive range of information in the World Wide Web, which offers quick and easy access to all data required.

Under the address

www.siemens.com/industry

you will find everything you need to know about products, systems and services.

Product Selection Using the Interactive Catalog CA 01 of Industry



Detailed information together with convenient interactive functions:

The interactive catalog CA 01 covers more than 80 000 products and thus provides a full summary of the Siemens Industry Automation and Drive Technologies product base.

Here you will find everything that you need to solve tasks in the fields of automation, switchgear, installation and drives. All information is linked into a user interface which is easy to work with and intuitive.

After selecting the product of your choice you can order at the press of a button, by fax or by online link.

Information on the interactive catalog CA 01 can be found in the Internet under

www.siemens.com/automation/ca01

or on DVD.

Easy Shopping with the Industry Mall

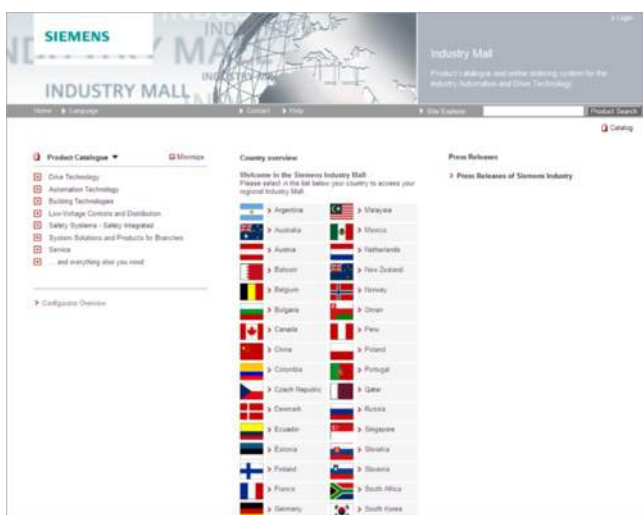

The Industry Mall is the virtual department store of Siemens AG on the Internet. Here you have access to a huge range of products presented in electronic catalogs in an informative and attractive way.

Data transfer via EDIFACT allows the whole procedure from selection through ordering to tracking of the order to be carried out online via the Internet.

Numerous functions are available to support you.

For example, powerful search functions make it easy to find the required products, which can be immediately checked for availability. Customer-specific discounts and preparation of quotes can be carried out online as well as order tracking and tracing.

Please visit the Industry Mall on the Internet under:

www.siemens.com/industrymall

Downloading Catalogs

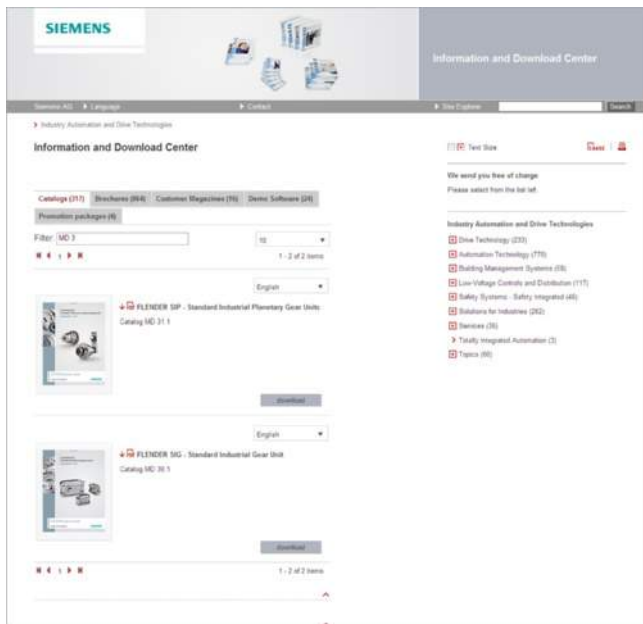

In addition to numerous other useful documents, you can also find the catalogs listed on the back inside cover of this catalog in the Information and Download Center. Without having to register, you can download these catalogs in PDF format or increasingly as digital page-turning e-books.

The filter dialog box above the first catalog displayed makes it possible to carry out targeted searches. If you enter "MD 3" for example, you will find both the MD 30.1 and MD 31.3 catalogs. If you enter "ST 70" both the ST 70 catalog and the associated news or add-ons are displayed.

Visit us on the web at:

www.siemens.com/industry/infocenter

Social Media

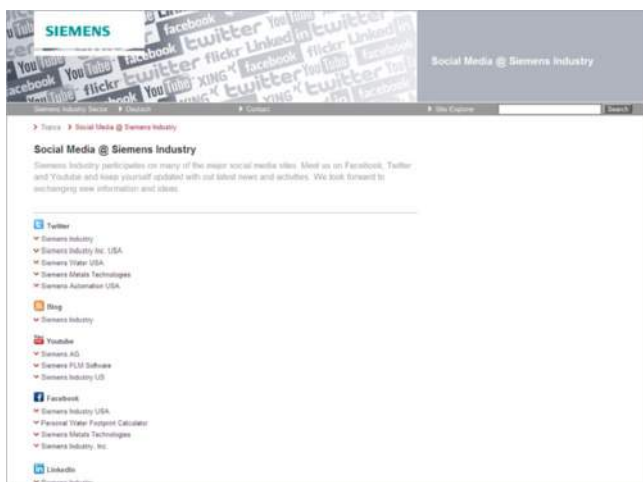

Connect with Siemens through social media: visit our social networking sites for a wealth of useful information, demos on products and services, the opportunity to provide feedback, to exchange information and ideas with customers and other Siemens employees, and much, much more. Stay in the know and follow us on the ever-expanding global network of social media.

Connect with Siemens Industry at our central access point:

www.siemens.com/industry/socialmedia

Or via our product pages at:

www.siemens.com/automation

or

www.siemens.com/drives

To find out more about Siemens' current social media activities visit us at:

www.siemens.com/socialmedia

Mobile Media



Discover the world of Siemens.

We are also constantly expanding our offering of cross-platform apps for smartphones and tablets. You will find the current Siemens apps at the app store (iOS) or at Google Play (Android).

The Siemens app, for example, tells you all about the history, latest developments and future plans of the company – with informative pictures, fascinating reports and the most recent press releases.

Appendix Industry Services

Your machines and plant can do more – with Industry Services



Whether it is production or process industry - in view of rising cost pressure, growing energy costs, and increasingly stringent environmental regulations, services for industry are a crucial competitive factor in manufacturing as well as in process industries.

All over the world Siemens supports its customers with product, system, and application-related services throughout the entire life cycle of a plant. Right from the earliest stages of planning, engineering, and building, all the way to operation and modernization. These services enable customers to benefit from the Siemens experts' unique technological and product knowledge and industry expertise.

Thus downtimes are reduced and the utilization of resources is optimized. The bottom line: increased plant productivity, flexibility, and efficiency, plus reduced overall costs.

Discover all advantages of our service portfolio:
www.siemens.com/industry-services

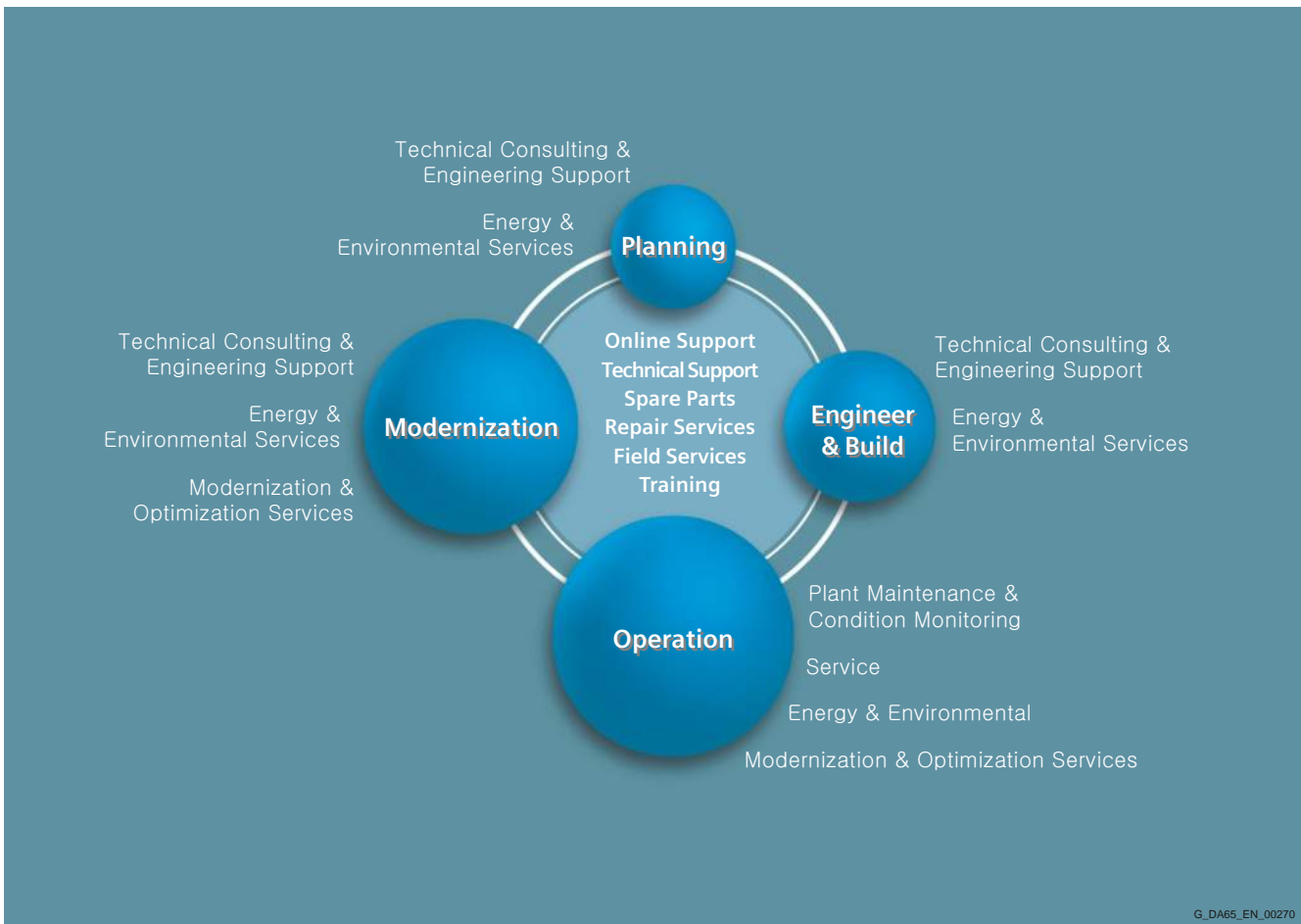

G_DA65_EN_00270

Siemens supports its clients with technology based Services across a plants entire life cycle.

Online Support

Online support is a comprehensive information system for all questions relating to products, systems, and solutions that Siemens has developed for industry over time. With more than 300,000 documents, examples and tools, it offers users of automation and drive technology a way to quickly find up-to-date information. The 24-hour service enables direct, central access to detailed product information as well as numerous solution examples for programming, configuration and application.

The content, in six languages, is increasingly multimediated – and now also available as a mobile app. Online support's "Technical Forum" offers users the opportunity to share information with each other. The "Support Request" option can be used to contact Siemens' technical support experts. The latest content, software updates, and news via newsletters and Twitter ensure that industry users are always up to date.



www.siemens.com/industry/onlinesupport

Online Support App



Using the Online Support app, you can access over 300,000 documents covering all Siemens industrial products - anywhere, any time. Regardless of whether you need help implementing your project, fault-finding, expanding your system or are planning a new machine.

You have access to FAQs, manuals, certificates, characteristics curves, application examples, product notices (e.g. announcements of new products) and information on successor products in the event that a product is discontinued.

Just scan the product code printed on the product directly using the camera of your mobile device to immediately see all technical information available on this product at a glance. The graphical CAx information (3D model, circuit diagrams or EPLAN macros) is also displayed. You can forward this information to your workplace using the e-mail function.

The search function retrieves product information and articles and supports you with a personalized suggestion list. You can find your favorite pages – articles you need frequently – under "mySupport". You also receive selected news on new functions, important articles or events in the News section.

Scan the QR code
for information on
our Online Support
app.



The app is available free of charge from the Apple App Store (iOS) or from Google Play (Android).

www.siemens.com/industry/onlinesupportapp

Technical Support

The ability to quickly analyze system and error messages and take appropriate action are key factors in ensuring that plants run safely and efficiently. Questions can arise at any time and in any industry, whether it's an individual product or a complete automation solution. Siemens technical support offers individual technical assistance in matters related to functionality, how to operate, applications, and fault clearance in industrial products and systems – at any time and globally, over the phone, by e-mail, or via remote access. Experienced experts from Siemens answer incoming questions promptly. Depending on the requirements, they first consult specialists in the areas of development, on-site services, and sales. Technical support is also available for discontinued products that are no longer available. Using the support request number, any inquiry can be clearly identified and systematically tracked.



Appendix

Industry Services

Industry Services for the entire life cycle

Spare Parts

Drive and automation systems must be available at all times. Even a single missing spare part can bring the entire plant to a standstill – and result in substantial financial losses for the operator. The spare parts services from Siemens protects against such losses – with the aid of quickly available, original spare parts that ensure smooth interaction with all other system components. Spare parts are kept on hand for up to ten years; defective parts can be returned. For many products and solutions, individual spare parts packages ensure a preventive stock of spare parts on-site. The spare parts services is available around the world and around the clock. Optimum supply chain logistics ensure that replacement components reach their destination as quickly as possible. Siemens' logistics experts take care of planning and management as well as procurement, transportation, customs handling, warehousing, and complete order management for spare parts.



Repair Services

Reliable electrical and electronic equipment is crucial for operating continuous processes. That is why it is essential that motors and converters always undergo highly specialized repair and maintenance. Siemens offers complete customer and repair services – on site and in repair centers – as well as technical emergency services worldwide. The repair services include all measures necessary to quickly restore the functionality of defective units. In addition, services such as spare parts logistics, spare parts storage and rapid manufacturing are available to plant operators in all verticals. With a global network of certified repair shops operated by Siemens as well as third parties, Siemens handles the maintenance and overhaul of motors, converters, and other devices as an authorized service partner.



Field Services

It's a top priority in all industries: the availability of plants and equipment. Siemens offers specialized maintenance services such as inspection and upkeep as well as rapid fault clearance in industrial plants – worldwide, continuously, and even with emergency services as needed. The services include startup as well as maintenance and fault clearance during operation. The startup service includes checking the installation, function tests, parameterization, integration tests for machines and plants, trial operation, final acceptance, and employee training. All services, including remote maintenance of drives, are also available as elements of customized service contracts.



Training

Increasingly, up-to-date knowledge is becoming a determining factor in success. One of the key resources of any company is well-trained staff that can make the right decision at the right moment and take full advantage of the potential. With SITRAIN – Training for Industry, Siemens offers comprehensive advanced training programs. The technical training courses convey expertise and practical knowledge directly from the manufacturer. SITRAIN covers Siemens' entire product and system portfolio in the field of automation and drives. Together with the customer, Siemens determines the company's individual training needs and then develops an advanced training program tailored to the desired requirements. Additional services guarantee that the knowledge of all Siemens partners and their employees is always up-to-date.



Technical Consulting & Engineering Support

The efficiency of plants and processes leads to sustainable economic success. Individual services from Siemens help save substantial time and money while also guaranteeing maximum safety. Technical consulting covers the selection of products and systems for efficient industrial plants. The services include planning, consulting, and conceptual design as well as product training, application support, and configuration verification – in all phases of a plant's lifecycle and in all questions related to product safety. Engineering support offers competent assistance throughout the entire project, from developing a precise structure for startup to product-specific preparation for implementation as well as support services in areas such as prototype development, testing and acceptance.



Energy & Environmental Services

Efficient energy use and resource conservation – these top sustainability concerns pay off – both for the environment and for companies. Siemens offers integrated solutions that unlock all technical and organizational potential for successful environmental management. Customized consulting services are aimed at sustainably lowering the cost of energy and environmental protection and thus increasing plant efficiency and availability. The experts provide support in the conceptual design and implementation of systematic solutions in energy and environmental management, enabling maximum energy efficiency and optimized water consumption throughout the entire company. Improved data transparency makes it possible to identify savings potential, reduce emissions, optimize production processes, and thereby noticeably cut costs.



Appendix

Industry Services

Industry Services for the entire life cycle

Modernization & Optimization Services

High machine availability, expanded functionality and selective energy savings – in all industries, these are decisive factors for increasing productivity and lowering costs. Whether a company wants to modernize individual machines, optimize drive systems, or upgrade entire plants, Siemens' experts support the projects from planning to commissioning.

Expert consulting and project management with solution responsibility lead to security and make it possible to specifically identify savings potential in production. This secures investments over the long term and increases economic efficiency in operation.



Plant Maintenance & Condition Monitoring

Modern industrial plants are complex and highly automated. They must operate efficiently in order to ensure the company's competitive strength. In addition, the steadily increasing networking of machines and plants require consistent security concepts. Maintenance and status monitoring as well as the implementation of integrated security concepts by Siemens' experts support optimum plant use and avoid downtime. The services include maintenance management as well as consulting on maintenance concepts, including the complete handling and execution of the necessary measures. Complete solutions also cover remote services, including analysis, remote diagnosis, and remote monitoring. These are based on the Siemens Remote Services platform with certified IT security.



Service Contracts

Making maintenance costs calculable, reducing interfaces, speeding up response times, and unburdening the company's resources – the reduced downtimes that these measures achieve increase the productivity of a plant. Service contracts from Siemens make maintenance and repairs more cost-effective and efficient. The service packages include local and remote maintenance for a system or product group in automation and drive technology. Whether you need extended service periods, defined response times, or special maintenance intervals, the services are compiled individually and according to need. They can be adjusted flexibly at any time and used independently of each other. The expertise of Siemens' specialists and the capabilities of remote maintenance thus ensure reliable and fast maintenance processes throughout a plant's entire lifecycle.



Overview

Software types

Software requiring a license is categorized into types. The following software types have been defined:

- Engineering software
- Runtime software

Engineering software

This includes all software products for creating (engineering) user software, e.g. for configuring, programming, parameterizing, testing, commissioning or servicing.

Data generated with engineering software and executable programs can be duplicated for your own use or for use by third-parties free-of-charge.

Runtime software

This includes all software products required for plant/machine operation, e.g. operating system, basic system, system expansions, drivers, etc.

The duplication of the runtime software and executable programs created with the runtime software for your own use or for use by third-parties is subject to a charge.

You can find information about license fees according to use in the ordering data (e.g. in the catalog). Examples of categories of use include per CPU, per installation, per channel, per instance, per axis, per control loop, per variable, etc.

Information about extended rights of use for parameterization/configuration tools supplied as integral components of the scope of delivery can be found in the readme file supplied with the relevant product(s).

License types

Siemens Industry Automation & Drive Technologies offers various types of software license:

- Floating license
- Single license
- Rental license
- Rental floating license
- Trial license
- Demo license
- Demo floating license

Floating license

The software may be installed for internal use on any number of devices by the licensee. Only the concurrent user is licensed. The concurrent user is the person using the program. Use begins when the software is started. A license is required for each concurrent user.

Single license

Unlike the floating license, a single license permits only one installation of the software per license.

The type of use licensed is specified in the ordering data and in the Certificate of License (CoL). Types of use include for example per instance, per axis, per channel, etc.

One single license is required for each type of use defined.

Rental license

A rental license supports the "sporadic use" of engineering software. Once the license key has been installed, the software can be used for a specific period of time (the operating hours do not have to be consecutive).

One license is required for each installation of the software.

Rental floating license

The rental floating license corresponds to the rental license, except that a license is not required for each installation of the software. Rather, one license is required per object (for example, user or device).

Trial license

A trial license supports "short-term use" of the software in a non-productive context, e.g. for testing and evaluation purposes. It can be transferred to another license.

Demo license

The demo license support the "sporadic use" of engineering software in a non-productive context, for example, use for testing and evaluation purposes. It can be transferred to another license. After the installation of the license key, the software can be operated for a specific period of time, whereby usage can be interrupted as often as required.

One license is required per installation of the software.

Demo floating license

The demo floating license corresponds to the demo license, except that a license is not required for each installation of the software. Rather, one license is required per object (for example, user or device).

Certificate of license (CoL)

The CoL is the licensee's proof that the use of the software has been licensed by Siemens. A CoL is required for every type of use and must be kept in a safe place.

Downgrading

The licensee is permitted to use the software or an earlier version/release of the software, provided that the licensee owns such a version/release and its use is technically feasible.

Delivery versions

Software is constantly being updated. The following delivery versions

- PowerPack
- Upgrade

can be used to access updates.

Existing bug fixes are supplied with the ServicePack version.

PowerPack

PowerPacks can be used to upgrade to more powerful software. The licensee receives a new license agreement and CoL (Certificate of License) with the PowerPack. This CoL, together with the CoL for the original product, proves that the new software is licensed.

A separate PowerPack must be purchased for each original license of the software to be replaced.

Upgrade

An upgrade permits the use of a new version of the software on the condition that a license for a previous version of the product is already held.

The licensee receives a new license agreement and CoL with the upgrade. This CoL, together with the CoL for the previous product, proves that the new version is licensed.

A separate upgrade must be purchased for each original license of the software to be upgraded.

Appendix

Software Licenses

Overview

ServicePack

ServicePacks are used to debug existing products. ServicePacks may be duplicated for use as prescribed according to the number of existing original licenses.

License key

Siemens Industry Automation & Drive Technologies supplies software products with and without license keys.

The license key serves as an electronic license stamp and is also the "switch" for activating the software (floating license, rental license, etc.).

The complete installation of software products requiring license keys includes the program to be licensed (the software) and the license key (which represents the license).

Software Update Service (SUS)

As part of the SUS contract, all software updates for the respective product are made available to you free of charge for a period of one year from the invoice date. The contract will automatically be extended for one year if it is not canceled three months before it expires.

The possession of the current version of the respective software is a basic condition for entering into an SUS contract.

You can download explanations concerning license conditions from www.siemens.com/automation/salesmaterial-as/catalog/en/terms_of_trade_en.pdf

A	
Accessories	4/53, 5/247, 6/149, 9/38, 12/6
Accessories for ET 200pro motor starters	9/306
Accessories for SIMATIC TDC	10/9
Active RS 485 terminating element	9/347
Additional documentation	15/3
Additional software	11/60
ADDM - Data Management	11/59
Add-on products for the ET 200S	9/184
Analog electronic modules	9/230
Analog modules	3/71, 4/19, 5/70, 6/64
Applicable practical know-how	15/10
AS-Interface connection for LOGO!	3/26
ASM 475	5/212, 9/215
Automation systems	14/9
B	
BaseUnits	9/32
Basic Panels – Standard	3/124
BB 1297 Battery Board	3/104
Bus adapters	9/37
C	
Catalog improvement suggestions	15/29
CB 1241 communication board RS485	3/107
CE marking	15/6
Central processing units	3/4, 4/4, 5/4, 6/4
Certificates	15/7
CFC	11/19
CM 1241 communication modules	3/105
CM 1242-5	3/108
CM 1243-2	3/110
CM 1243-5	3/111
CM 1542-5	4/34
CM IO-Link	9/30
CM PtP	4/31
CM PtP serial interface	9/28
Communication	3/105, 4/31, 5/159, 5/199, 5/201, 6/103, 7/11, 9/28, 9/214
Communications software	12/7
Compact CPUs	5/18
Conditions of sale and delivery	15/32
Connection methods	5/223, 6/128
Connection system	4/39, 4/40, 4/41, 4/47
Connections/interfaces	9/340
Controller Software inside TIA Portal	11/4, 11/7
CP 1242-7 GPRS module	3/115
CP 1543-1	4/36
CP 1604	7/15
CP 340	5/159
CP 341	5/161
CP 342-5	5/167
CP 342-5 FO	5/169
CP 343-1	5/176
CP 343-1 Advanced	5/179
CP 343-1 ERPC	5/185
CP 343-1 Lean	5/173
CP 343-2 P, CP 343-2	5/165
CP 343-5	5/171
CP 440	6/103
CP 441-1, CP 441-2	6/104
CP 443-1	6/112
CP 443-1 Advanced	6/115
CP 443-5 Basic	6/108
CP 443-5 Extended	6/110
CP 5603	7/11
CP51M1 communications module	10/5
CP53M0 communications module	10/5
CPU 1211C	3/4
CPU 1212C	3/8
CPU 1214C	3/12
CPU 1215C	3/16
CPU 1217C	3/20
CPU 412	6/4
CPU 412H	6/35
CPU 414	6/8
CPU 414F	6/26
CPU 414H	6/35
CPU 416	6/13
CPU 416F	6/30
CPU 416H	6/35
CPU 417	6/18
CPU 417H	6/35
CPU551 processor module	10/3
CSM 1277 unmanaged	3/113
CSM 377 unmanaged	5/188
D	
D7-SYS	11/48
Development kit for ERTEC	9/345
DeviceNet interface modul	9/185
Diagnostic repeater for PROFIBUS DP	9/336
Digital electronic modules	9/224
Digital modules	3/40, 4/10, 5/49, 6/56
Digital output modules	9/11
DM 370 dummy modules	5/158
DOCPRO	11/28
DP/DP coupler	9/351
Drive ES engineering software	11/49
Drive systems	14/2
E	
Easy Motion Control	11/46
EC31	7/2
Embedded bundles/ Software packages	7/18, 7/20, 7/23, 7/25, 7/31
Enhanced Real-Time Ethernet Controller ERTEC	9/342
ET 200eco	9/327
ET 200eco PN	9/312
ET 200iSP	9/218
ET 200iSP watchdog module	9/244
ET 200M	9/191
ET 200MP	9/186
ET 200pro	9/253
ET 200pro isolator module	9/301
ET 200pro motor starters	9/296
General data	9/296
High Feature motor starters	9/300
Standard motor starters	9/299
ET 200pro Safety motor starter Solutions local/PROFIsafe	9/302
Safety local modules	9/302
Safety PROFIsafe modules	9/305
ET 200S	9/39
ET 200SP	9/5
EtherNet/IP interface module	9/184
Ex analog input modules	5/104
Ex analog modules	5/104, 5/107
Ex analog output modules	5/107
Ex digital input modules	5/100
Ex digital modules	5/100, 5/102
Ex digital output modules	5/102
Expansion modules	7/10
External prommer	12/6
F	
F digital / analog modules	5/88
Fail-safe CPUs	5/33, 6/26
Fail-safe electronic modules	9/241
F analog input module	9/241
F digital input module	9/235
F digital output module	9/238
Fail-safe I/O modules	6/158, 9/133
F electronic module relays	9/140
F electronic modules	9/137
F terminal modules	9/142
Overview	9/133
PM-E F PROFIsafe F power module	9/134
SIPLUS F electronic modules	9/144
Fan subassembly	6/133
Field PG M4	12/2
Flexible connection	4/47, 6/130
FM 350-1 counter modules	5/109
FM 350-2 counter modules	5/111
FM 351 positioning modules	5/113
FM 352 cam controllers	5/115
FM 352-5 high-speed Boolean processor	5/117
FM 353 positioning modules	5/121
FM 354 positioning modules	5/123
FM 355 controller modules	5/127
FM 355-2 temperature controller modules	5/132
FM 357-2 positioning modules	5/125
FM 450-1 counter module	6/77
FM 451 positioning module	6/79
FM 452 cam controller	6/81
FM 453 positioning module	6/83
FM 455 controller module	6/85
FM 458-1 DP application module	6/90
EXM 448 universal communications expansion module	6/95
EXM 448-2 universal communications expansion module	6/96
Accessories	6/98
D7-SYS	6/97
EXM 438-1 input/output expansion	6/93
FM 458-1 DP basic module	6/91
Front connectors	4/39, 5/223, 6/128
Function modules	5/109, 6/77, 9/212
Fuzzy Control	11/41

Appendix

Index

G	
GlobalDataMemory	10/8
H	
HARDNET-IE S7-REDCONNECT	12/9
High-availability CPUs	6/35
I	
I/O modules	9/9, 9/69, 9/128, 9/190
Analog electronic modules	9/90
Analog expansion modules	9/279
Analog input module with HART	9/201
Analog input modules	9/18
Analog output module with HART	9/203
Analog output modules	9/22
Digital electronic modules	9/75
Digital expansion modules	9/273
Digital input modules	9/9
Digital/analog modules	9/200
ET 200pro pneumatic interface	9/290
Ex-analog input module with HART	9/205
Ex-analog output module with HART	9/207
Fail-safe digital expansion modules	9/286
PM-E power module	9/287
PM-O power module output	9/289
Potential isolation module	9/74
Power modules for	
PM-E electronic modules	9/69
SIMATIC RF170C	9/292
SIPLUS analog electronic modules	9/106
SIPLUS analog input module with HART	9/209
SIPLUS analog output module with HART	9/210
SIPLUS digital electronic modules	9/88
SIPLUS Ex analog input module with HART	9/211
SIPLUS power modules for PM-E electronic modules	9/71
SIPLUS terminal modules for power and electronic modules	9/130
Spare modules	9/73
Terminal modules for power modules and electronic modules	9/128
IM 152-1 interface module	9/220
IM 153-1/153-2	6/151
IM 174 PROFIBUS modules	5/139
IM 360/361/365 interface modules	5/233
IM 460-0	6/135
IM 460-1	6/137
IM 460-3	6/139
IM 461-0	6/136
IM 461-1	6/138
IM 461-3	6/140
IM 463-2	6/141
Index	15/21
Industry Services	15/14
Industry Services for the entire life cycle ..	15/15
Information and Download Center	15/13
Information and Ordering in the Internet and on DVD	15/12
Information on software licensing	11/3
Interface module with fail-safe CPU	9/51
IM 151-7 F-CPU	9/51
IM 151-8 F PN/DP CPU	9/53
Interface modules	5/233, 6/135
Interface modules with CPU	9/41
IM 151-7 CPU	9/41
IM 151-8 PN/DP CPU	9/44
Master interface module for IM 151 CPU	9/47
Interface modules without CPU	9/58
IM 151-1	9/58
IM 151-3 PN	9/64
IM 155-6PN Standard	9/6
Interface modules	9/192
IM 153-1/153-2	9/192
IM 153-4 PN	9/195
IM 154-1 and IM 154-2	9/254
IM 154-4 PN	9/258
IM 154-6 PN IWLAN	9/261
IM 154-8 F PN/DP CPU	9/268
IM 154-8 PN/DP CPU	9/264
IM 155-5 PN	9/187
PROFIBUS module IF-964 DP	6/54
SIPLUS IM 155-5 PN	9/189
IO-Link master ET 200eco PN	9/324
IO-Link master modules	9/145
4SI IO-Link electronic module	9/145
4SI SIRIUS electronic module	9/146
Isolation modules	5/96, 6/156
K	
KNX/EIB2S7	11/60
L	
Labeling sheets	4/53, 5/248, 6/149
Load power supplies	4/50
Loadable drivers for CP 441-2 and CP 341	5/163, 6/106
LOGO!	2/2
LOGO! CM EIB/KNX communication modules	2/23
LOGO! CSM unmanaged	2/24
LOGO! logic module	2/2
LOGO! modular	2/3
LOGO! modular basic variants	2/3
LOGO! modular expansion modules	2/14
LOGO! modular pure variants	2/9
LOGO! Software	2/41
LOGO!Contact	2/40
LOGO!Power	2/27
M	
MC5xx program memory module	10/4
MD741-1 EGPRS Router	5/204
Measuring systems	14/9
Measuring systems	14/9
Mobile Media	15/13
Modular PID Control	11/37
Modules for SIMATIC S7-400F/FH	6/151
MOTION-CONNECT connection systems	14/13
Motor starters and safety motor starters....	9/147
Accessories.....	9/175
ET 200S Failsafe motor starters	9/161
Failsafe terminal modules	9/163
General data	9/147
High Feature motor starters.....	9/156
High Feature terminal modules	9/158
Power module	9/159
Safety local and PROFIsafe modules....	9/164
Standard motor starters	9/153
Standard terminal modules	9/154
Terminal module for power module	9/160
Mounting rails	4/53, 5/247
N	
Network components for PROFIBUS	9/346, 9/347
Network transitions	9/350, 9/351
NeuroSystems	11/43
O	
Online Services	15/12
OPC server for Industrial Ethernet	12/15
Operator control and monitoring	3/124
Options for diagnostics and service	11/29
Options for engineering and drive technology	11/34
Options for programming and design	11/19
Order No. index	15/25
Overvoltage protection	14/6
P	
Partners at Industry Automation and Drive Technologies	15/8
PID Professional V11	11/34
PID Self-Tuner	11/40
PN CBA OPC server	12/17
PN/PN coupler	9/350
Power Rail Booster	9/335
Power supplies	3/121, 4/48, 4/50, 5/235, 6/144, 9/217
Power supply units	9/222
PRODAVE	11/33
PROFIBUS components	9/335, 9/336, 9/338, 9/340
PROFIBUS DP ASICs	9/338
PROFINET components	9/342, 9/345
Programming devices	12/2
PS 405/407 power supply	6/144
Q	
Quality management	15/7
R	
Racks	6/131, 6/133
Repeater RS 485 for PROFIBUS	9/346
Reserve module	9/245
RS 485-IS coupler	9/248

S		
S7 Distributed Safety	11/21	
S7 F/FH Systems	11/22	
Introduction	11/22	
S7 F Systems	11/23	
SIMATIC Safety Matrix	11/24	
S7-1200	3/2	
S7-1500	4/2	
S7-300/S7-300F	5/2	
S7-400/S7-400H/S7-400F/FH	6/2	
S7-GRAPH	11/16	
S7-PDIAG	11/29	
S7-PLCSIM	11/18	
S7-SCL	11/14	
S7-Technology	11/45	
SB 1221 digital input modules	3/43	
SB 1222 digital output modules	3/50	
SB 1223 digital input/output modules	3/58	
SB 1231 analog input modules	3/75	
SB 1231 RTD signal boards	3/93	
SB 1231 thermocouple signal boards	3/88	
SB 1232 analog output modules	3/80	
SCALANCE M87x UMTS router	5/207, 6/120	
SICLOCK	14/12	
SICROWBAR overvoltage protection	14/6	
Siemens Automation Cooperates with Education	15/10	
Siemens contacts worldwide	15/8	
Siemens Industry Training	15/2	
Siemens Solution Partner Automation	15/9	
SIFLOW FC070	5/150	
SIM 1274 simulator	3/103	
SIMATIC Controllers	2/9	
SIMATIC ET 200	2/13	
SIMATIC ET 200 Distributed IO	9/4	
SIMATIC ET200pro PS	9/294	
SIMATIC Field PG M4	2/10, 12/2	
SIMATIC HMI 2/14	13/5	
SIMATIC HMI IPC477C bundles	7/25	
SIMATIC Ident	13/11	
SIMATIC iMap	11/26	
SIMATIC IPC	2/11	
SIMATIC IPC227D bundles	7/18	
SIMATIC IPC277D bundles	7/23	
SIMATIC IPC427C bundles	7/20	
SIMATIC Maintenance Station	11/51	
SIMATIC Manual Collection	15/5	
SIMATIC Modular Controllers	2/3	
SIMATIC NET	2/16, 13/10	
SIMATIC PC-based controllers	8/2, 8/8, 8/14	
SIMATIC PCS 7	2/15, 13/2	
SIMATIC PDM	11/53	
SIMATIC programming devices	2/10	
SIMATIC S7-1200	2/3	
SIMATIC S7-1200 PM 1207	3/121	
SIMATIC S7-1500	2/4	
SIMATIC S7-300	2/5	
SIMATIC S7-400	2/7	
SIMATIC S7-modular Embedded Controller	7/2, 7/10	
SIMATIC software	2/12	
SIMATIC TDC multiprocessor control system	10/2	
SIMATIC TOP connect for SIMATIC S7-300 and ET 200M	5/224	
SIMATIC TOP connect for SIMATIC S7-400	6/129	
SIMATIC TOP connect for SIMATIC S7	4/40, 5/225	
Flexible connection	5/232	
Fully modular connection	4/41, 5/225	
SIMATIC TOP connect system cabling for SIMATIC S7-1500 and ET 200MP	4/40	
SIMATIC WinAC ODK	8/14	
SIMATIC WinAC RTX	8/2	
SIMATIC WinAC RTX (F) Embedded Bundles	2/9	
SIMATIC WinAC RTX F	8/8	
SIMOTION Motion Control System	14/9	
SINAMICS	14/2	
SINUMERIK CNC automation systems	14/10,	
SIPLUS analog input modules	9/24	
SIPLUS analog modules	3/95, 4/26, 5/83, 6/75	
SIPLUS analog output modules	9/26	
SIPLUS BaseUnits	9/34	
SIPLUS Basic Panels	3/134	
SIPLUS central processing units	3/23	
SIPLUS CM 1241 communication modules	3/117	
SIPLUS CM 1242-5 communication modules	3/119	
SIPLUS CM 1243-5 communication modules	3/120	
SIPLUS communication	3/117, 5/214, 6/125	
SIPLUS compact CPUs	5/28	
SIPLUS CP 340	5/214	
SIPLUS CP 341	5/215	
SIPLUS CP 343-1	5/217	
SIPLUS CP 343-1 Advanced	5/219	
SIPLUS CP 343-1 Lean	5/216	
SIPLUS CP 443-1	6/125	
SIPLUS CP 443-1 Advanced	6/126	
SIPLUS CPU 1211C	3/23	
SIPLUS CPU 1212C	3/27	
SIPLUS CPU 1214C	3/31	
SIPLUS CPU 1215C	3/36	
SIPLUS DCF 77 radio clock module	5/156, 6/102	
SIPLUS diagnostic repeater for PROFIBUS	9/341	
SIPLUS digital input modules	9/14	
SIPLUS digital modules	3/61, 4/17, 5/65, 6/62	
SIPLUS digital output modules	9/16	
SIPLUS DP active RS485 terminating element	9/349	
SIPLUS F digital/analog modules	5/97	
SIPLUS fail-safe CPUs	5/40	
SIPLUS FM 350-1 counter modules	5/153	
SIPLUS FM 350-2 counter modules	5/154	
SIPLUS FM 450-1 counter modules	6/101	
SIPLUS function modules	5/153, 6/101	
SIPLUS high-availability CPUs	6/45	
SIPLUS CPU 412H	6/45	
SIPLUS CPU 414H	6/47	
SIPLUS CPU 417H	6/49	
SIPLUS IM 153-1/153-2	6/154	
SIPLUS IM 365 interface modules	5/234	
SIPLUS IM 460-0	6/142	
SIPLUS IM 461-0	6/143	
SIPLUS interface modules	5/234, 6/143, 9/8	
SIPLUS interface modules with CPU	9/48	
SIPLUS IM151-7 CPU	9/48	
SIPLUS IM151-8 PN/DP CPU	9/49	
SIPLUS master interface modules for IM 151 CPU	9/50	
SIPLUS interface modules with fail-safe CPU	9/56	
SIPLUS IM 151-7 F-CPU	9/56	
SIPLUS IM 151-8 F PN/DP CPU	9/57	
SIPLUS interface modules without CPU	9/67	
SIPLUS IM 151-1	9/67	
SIPLUS IM 151-3PN	9/68	
SIPLUS interface modules	9/197	
SIPLUS IM 153-1/153-2	9/197	
SIPLUS IM 153-4 PN IO	9/199	
SIPLUS isolation modules	6/157	
SIPLUS LOGO! modular basic variants	2/7	
SIPLUS LOGO! modular expansion modules	2/19	
SIPLUS LOGO! modular pure variants	2/12	
SIPLUS LOGO!Power	2/39	
SIPLUS module racks	6/134	
SIPLUS network components for PROFIBUS	9/348	
SIPLUS operator control and monitoring	3/134	
SIPLUS PM 1207 power supplies	3/123	
SIPLUS power supplies	3/123, 4/52, 5/244, 6/148	
SIPLUS PROFIBUS components for ET 200	9/341	
SIPLUS PROFIBUS IF-964 DP module	6/55	
SIPLUS racks	6/134	
SIPLUS RS 485 repeater	9/348	
SIPLUS S7-300 PS 305	5/244	
SIPLUS S7-300 PS 307, 10 A	5/246	
SIPLUS S7-300 PS 307, 5 A	5/245	
SIPLUS SB 1223 digital input/output modules	3/69	
SIPLUS SB 1232 analog output modules	3/99	
SIPLUS SIWAREX U	5/155	
SIPLUS SM 1221 digital input modules	3/61	
SIPLUS SM 1222 digital output modules	3/63	
SIPLUS SM 1223 digital input/output modules	3/66	
SIPLUS SM 1232 analog output modules	3/97	
SIPLUS SM 1234 analog input/output modules	3/101	
SIPLUS SM 321 digital input modules	5/65	
SIPLUS SM 322 digital output modules	5/67	
SIPLUS SM 323 digital input/output modules	5/69	
SIPLUS SM 326 F digital input modules - Safety Integrated	5/97	
SIPLUS SM 326 F digital output modules - Safety Integrated	5/98	
SIPLUS SM 331 analog input modules	5/83	
SIPLUS SM 332 analog output modules	5/85	
SIPLUS SM 334 analog input/output modules	5/87	
SIPLUS SM 336 F analog input modules - Safety Integrated	5/99	
SIPLUS SM 421 digital input module	6/62	
SIPLUS SM 422 digital output module	6/63	
SIPLUS SM 431 analog input module	6/75	
SIPLUS SM 432 analog output module	6/76	
SIPLUS SM 521 digital modules	4/17	
SIPLUS SM 522 digital modules	4/18	

Appendix

Index

SIPLUS SM 531 analog modules	4/26	SM 421 digital input module	6/56	T	
SIPLUS SM 532 analog modules	4/27	SM 422 digital output module	6/59	Technical product data	
SIPLUS SM 1231 analog input modules	3/95	SM 431 analog input module	6/64	for CAX applications	11/50
SIPLUS Standard CPUs	5/15, 6/21	SM 432 analog output module	6/73	Technology CPUs	5/44
SIPLUS CPU 412	6/21	SM 521 digital input modules	4/10	Technology modules	4/28, 9/108
SIPLUS CPU 414	6/22	SM 522 digital output modules	4/13	1 COUNT	
SIPLUS CPU 416	6/23	SM 531 analog input modules	4/19	24 V/100 kHz counter module	9/115
SIPLUS CPU 417	6/25	SM 532 analog output modules	4/23	1 COUNT	
SIPLUS sync module		SM500 I/O Module	10/6	5 V/500 kHz counter module	9/118
for connecting the CPU 41xH	6/51	SNMP OPC server	12/19	1 POS U positioning module	9/113
SIPLUS system power supplies	4/52	Social Media	15/13	1SI interface module	9/121
SIPLUS TIM 3V-IE for WAN and Ethernet	5/221	SOFTNET for Industrial Ethernet	12/11	1STEP stepper module	9/112
SIPLUS TIM 4R-IE for WAN and Ethernet	5/222	SOFTNET for PROFIBUS	12/7	2 PULSE pulse generator	9/110
SIPLUS Y-Link for S7-400H	6/53	SOFTNET PN IO	12/13	SIPLUS 1 COUNT	
SIRIUS relays	14/7	Software	3/136	24V/100kHz counter module	9/117
SIWAREX FTA	5/144	Software for joint tasks		SIPLUS 1 SI interface module	9/123
SIWAREX FTC	5/147	in the administration sector	11/57	SIWAREX CF	9/126
SIWAREX U	5/141	Software for joint tasks		SIWAREX CS	9/124
SM 1221 digital input modules	3/40	in the documentation sector	11/50	SSI module	9/108
SM 1222 digital output modules	3/46	Software for joint tasks		TeleService	11/30
SM 1223 digital input/output modules	3/53	in the maintenance sector	11/51	Terminal modules	9/247
SM 1231 analog input modules	3/71	Software for SIMATIC Controller	11/2	Terminal modules f or	
SM 1231 RTD signal modules	3/90	Software Licenses	15/19	Safety local and PROFIsafe modules	9/173
SM 1231 thermocouple modules	3/85	Software packages for SIMATIC IPC		The S7-300 version	5/235
SM 1232 analog output modules	3/77	and S7-mEC	7/31	TIM 3V-IE Advanced	5/193
SM 1234 analog input/output modules	3/82	Software redundancy	11/25	TIM 3V-IE DNP3	5/199
SM 321 digital input modules	5/49	Software Motor Starter ES	9/180, 9/311	TIM 3V-IE for WAN and Ethernet	5/190
SM 322 digital output modules	5/55	Spare parts	4/54, 6/150	TIM 4R-IE DNP3	5/201
SM 323/SM 327		Special modules	3/103, 5/157, 9/214	TIM 4R-IE for WAN and Ethernet	5/196
digital input/output modules	5/61	Specialist books		Time synchronization	14/12
SM 326 F digital input modules -		for automation engineering	15/3	Timing, coupling and monitoring relays	14/7
Safety Integrated	5/88	Stainless steel wall enclosure	9/250	TM Count 2x24V counter modules	4/28
SM 326 F digital output modules -		Standard CPUs	4/4, 5/4, 6/4		
Safety Integrated	5/91	CPU 412	6/4	U	
SM 331 analog input modules	5/70	CPU 414	6/8	UR5213 rack	10/2
SM 332 analog output modules	5/77	CPU 416	6/13	V	
SM 334 analog input/output modules	5/80	CPU 417	6/18	Version cross manager	11/57
SM 336 F analog input modules -		Standard PID Control	11/35	Version Trail	11/58
Safety Integrated	5/94	Standards and approbations	15/6	Y	
SM 338 POS input modules	5/137	STEP 7	11/8	Y-link for S7-400H	6/42
SM 374 simulators	5/157	STEP 7 (TIA Portal)	11/4	Your machines and plant can do more –	
		STEP 7 Micro/WIN	11/13	with Industry Services	15/14
		STEP 7 Professional	11/10		
		STEP 7 programming software	11/8		
		STEP 7 Safety (TIA Portal)	11/7		
		Sync-module for coupling the CPU 41xH ...	6/41		
		System cabling	14/13		
		System power supplies	4/48		

2XV

2XV9 450- 9/202, 9/204, 9/206, 9/208,
..... 11/42, 11/44

3R

3RK1 005- 9/146
3RK1 301- 9/153, 9/157, 9/162
3RK1 304- 9/299, 9/300, 9/301, 9/304, 9/305
3RK1 400- 2/26
3RK1 901- 3/110, 9/278, 9/310, 9/326
3RK1 902- 9/266, 9/271, 9/295, 9/308,
..... 9/309, 9/323, 9/333, 9/334
3RK1 903- 9/155, 9/158, 9/159, 9/160,
..... 9/163, 9/172, 9/174, 9/176,
..... 9/177, 9/178, 9/179, 9/183
3RK1 911- 9/183, 9/295, 9/308, 9/309
3RK1 922- 9/177, 9/183, 9/308, 9/310
3RK7 243- 3/110
3RK7 271- 3/110
3RT1 900- 9/263, 9/278, 9/323, 9/326, 9/334
3RX9 802- 9/256, 9/259, 9/267, 9/272,
..... 9/278, 9/285, 9/286, 9/293,
..... 9/323, 9/334

3U

3UF7 946- 9/183

3Z

3ZS1 310- 9/182, 9/183
3ZX1 012- 9/146
3ZX10 12- 9/179
3ZX1012- 3/110

6AG1

6AG1 052- 2/8, 2/13
6AG1 053- 2/8, 2/13, 2/22
6AG1 055- 2/22
6AG1 057- 2/5, 2/11, 5/156, 6/102
6AG1 131- 9/15, 9/89
6AG1 132- 9/17, 9/89
6AG1 134- 9/25, 9/107
6AG1 135- 9/27, 9/107
6AG1 138- 9/50, 9/72, 9/117, 9/123, 9/144
6AG1 151- 9/48, 9/49, 9/56, 9/57, 9/67, 9/68
6AG1 153- 6/155, 9/198, 9/199
6AG1 155- 9/8, 9/189
6AG1 193- 9/15, 9/17, 9/25, 9/27,
..... 9/36, 9/48, 9/132
6AG1 195- 5/98, 6/155, 6/157, 9/198
6AG1 197- 6/53
6AG1 204- 6/22, 6/24
6AG1 211- 3/26
6AG1 212- 3/30
6AG1 214- 3/35
6AG1 215- 3/38, 3/39
6AG1 221- 3/62
6AG1 222- 3/65
6AG1 223- 3/26, 3/30, 3/35, 3/39, 3/68, 3/70

6AG1 231- 3/96
6AG1 232- 3/26, 3/30, 3/35, 3/39, 3/98, 3/100
6AG1 234- 3/102
6AG1 241- 3/118
6AG1 242- 3/119
6AG1 243- 3/120
6AG1 305- 5/244
6AG1 307- 5/243, 5/245, 5/246
6AG1 312- 5/28
6AG1 313- 5/29, 5/30
6AG1 314- 5/14, 5/31, 5/32
6AG1 315- 5/15, 5/16, 5/40, 5/41
6AG1 317- 5/17, 5/42, 5/43
6AG1 321- 5/66
6AG1 322- 5/68
6AG1 323- 5/69
6AG1 326- 5/97, 5/98
6AG1 331- 2/39, 5/84, 9/209, 9/211
6AG1 332- 3/123, 5/86, 9/210
6AG1 334- 5/87
6AG1 336- 5/99
6AG1 340- 5/214
6AG1 341- 5/215
6AG1 343- 5/216, 5/218, 5/220
6AG1 350- 5/153, 5/154
6AG1 365- 5/234
6AG1 400- 6/134
6AG1 405- 6/148
6AG1 407- 6/148
6AG1 412- 6/21, 6/46
6AG1 414- 6/22, 6/48
6AG1 416- 6/24
6AG1 417- 6/25, 6/50
6AG1 421- 6/62
6AG1 422- 6/63
6AG1 431- 6/75
6AG1 432- 6/76
6AG1 443- 6/125, 6/127
6AG1 450- 6/101
6AG1 460- 6/142
6AG1 461- 6/143
6AG1 500- 6/21, 6/22, 6/24
6AG1 505- 4/52
6AG1 521- 4/17
6AG1 522- 4/18
6AG1 531- 4/26
6AG1 532- 4/27
6AG1 647- 3/135
6AG1 654- 6/53
6AG1 800- 5/221, 5/222
6AG1 901- 6/22, 6/24
6AG1 950- 5/155
6AG1 952- 6/21, 6/22, 6/24, 6/25,
..... 6/46, 6/48, 6/50, 9/341,
..... 9/348, 9/349
6AG1 960- 6/52
6AG1 964- 6/22, 6/24, 6/55
6AG1 972- 6/21, 6/22, 6/24, 6/25,
..... 6/46, 6/48, 6/50, 9/341,
..... 9/348, 9/349

6AV

6AV2 114- 7/31
6AV2 115- 7/31
6AV2 124- 7/24
6AV6 382- 7/31
6AV6 613- 12/5
6AV6 623- 7/31
6AV6 643- 11/60
6AV6 647- 3/133
6AV6 651- 3/133
6AV6 671- 7/24
6AV6 691- 3/133
6AV7 671- 7/30
6AV7 672- 7/24, 7/30
6AV7 881- 7/23
6AV7 883- 7/28, 7/29, 7/32
6AV7 884- 7/28, 7/29, 7/32

6B

6BK1 700- 2/23
6BQ3 030- 11/59

6D

6DD1 600- 10/3
6DD1 607- 6/92, 6/94, 6/95, 6/96
6DD1 610- 10/3, 10/4
6DD1 640- 10/7
6DD1 660- 10/5, 10/8
6DD1 661- 10/4, 10/5
6DD1 681- 6/92, 6/94, 6/100,
..... 10/3, 10/7, 10/10
6DD1 682- 10/2
6DD1 684- 6/92, 6/94, 6/100,
..... 10/3, 10/7, 10/10
6DD1 805- 6/97, 11/48
6DL2 804- 9/250, 9/251, 9/252

6ED

6ED1 050- 2/5, 2/10, 2/18, 2/23
6ED1 052- 2/5, 2/10
6ED1 055- 2/5, 2/10, 2/18
6ED1 056- 2/5, 2/10, 2/11, 2/18
6ED1 057- 2/6, 2/18, 2/40, 9/177, 9/183
6ED1 058- 2/5, 2/11, 2/18, 2/41

6EP

6EP1 311- 2/37
6EP1 321- 2/37
6EP1 322- 2/37
6EP1 331- 2/37, 5/198, 5/203
6EP1 332- 2/37, 3/122, 4/8, 4/51, 9/188
6EP1 333- 9/188
6EP1 351- 2/37
6EP1 352- 2/37
6EP1 971- 5/243

6ES5

6ES5 710- 9/7, 9/43, 9/46, 9/52,
..... 9/55, 9/63, 9/66
6ES5 734- 12/5
6ES5 750- 5/116, 5/122

Appendix

Order No. index

6ES7 1

6ES7 131-.....	9/10, 9/87, 9/229
6ES7 132-.....	9/13, 9/87, 9/229
6ES7 133-.....	9/10, 9/21, 9/33, 9/38
6ES7 134-.....	9/21, 9/105, 9/234
6ES7 135-.....	9/23, 9/105, 9/234
6ES7 137-.....	9/29, 9/31
6ES7 138-.....	9/47, 9/70, 9/73, 9/74, 9/109, 9/111, 9/112, 9/114, 9/116, 9/120, 9/122, 9/136, 9/139, 9/141, 9/145, 9/223, 9/236, 9/239, 9/242, 9/244, 9/246
6ES7 141-.....	9/278, 9/323, 9/333
6ES7 142-.....	9/278, 9/323, 9/333
6ES7 143-.....	9/278, 9/333
6ES7 144-.....	9/285, 9/323
6ES7 145-.....	9/285, 9/323
6ES7 147-.....	9/323
6ES7 148-.....	9/286, 9/288, 9/289, 9/291, 9/295, 9/305, 9/323, 9/326, 9/333
6ES7 151-.....	9/43, 9/46, 9/52, 9/55, 9/62, 9/65, 9/136, 9/139, 9/141
6ES7 152-.....	9/221, 9/229, 9/234, 9/236, 9/239, 9/242, 9/244, 9/246
6ES7 153-.....	6/153, 9/194, 9/196
6ES7 154-.....	9/255, 9/259, 9/262, 9/265, 9/270, 9/286
6ES7 155-.....	9/7, 9/188
6ES7 158-.....	9/350, 9/351
6ES7 174-.....	5/140
6ES7 182-.....	9/340
6ES7 193-.....	4/8, 9/7, 9/10, 9/13, 9/21, 9/23, 9/29, 9/31, 9/33, 9/37, 9/38, 9/43, 9/46, 9/47, 9/52, 9/55, 9/62, 9/63, 9/66, 9/70, 9/74, 9/87, 9/105, 9/109, 9/111, 9/112, 9/116, 9/120, 9/122, 9/125, 9/127, 9/128, 9/129, 9/136, 9/142, 9/143, 9/145, 9/146, 9/188, 9/221, 9/223, 9/229, 9/234, 9/236, 9/239, 9/244, 9/246, 9/247, 9/350
6ES7 194-.....	9/255, 9/256, 9/257, 9/259, 9/260, 9/262, 9/263, 9/265, 9/266, 9/267, 9/270, 9/272, 9/278, 9/285, 9/286, 9/288, 9/289, 9/305, 9/310, 9/323, 9/326, 9/333, 9/334
6ES7 195-.....	5/90, 5/93, 5/95, 5/96, 5/170, 6/44, 6/153, 6/156, 9/63, 9/194, 9/196, 9/202, 9/204, 9/206, 9/208, 9/339, 9/340, 9/344, 9/345
6ES7 197-.....	6/44

6ES7 2

6ES7 211-.....	3/6
6ES7 212-.....	3/10
6ES7 214-.....	3/14
6ES7 215-.....	3/18
6ES7 217-.....	3/21

6ES7 221-.....	3/6, 3/10, 3/14, 3/18, 3/21, 3/42, 3/45
6ES7 222-.....	3/6, 3/10, 3/14, 3/18, 3/21, 3/49, 3/52
6ES7 223-.....	3/6, 3/10, 3/14, 3/18, 3/21, 3/57, 3/60
6ES7 231-.....	3/6, 3/10, 3/14, 3/18, 3/21, 3/74, 3/76, 3/87, 3/89, 3/92, 3/94
6ES7 232-.....	3/6, 3/10, 3/14, 3/18, 3/21, 3/79, 3/81
6ES7 234-.....	3/84
6ES7 241-.....	3/6, 3/10, 3/14, 3/18, 3/21, 3/106, 3/107
6ES7 274-.....	3/6, 3/10, 3/14, 3/18, 3/21, 3/103
6ES7 290-.....	3/6, 3/10, 3/11, 3/14, 3/15, 3/18, 3/19, 3/21, 3/42, 3/49, 3/57, 3/74, 3/84, 3/87, 3/92
6ES7 291-.....	3/6, 3/11, 3/15, 3/19, 3/42, 3/49, 3/57, 3/74, 3/79, 3/84, 3/87, 3/92, 3/106
6ES7 292-.....	3/6, 3/11, 3/14, 3/19, 3/21, 3/42, 3/45, 3/49, 3/52, 3/57, 3/60, 3/74, 3/76, 3/79, 3/81, 3/84, 3/87, 3/89, 3/92, 3/94, 3/107
6ES7 297-.....	3/18, 3/21, 3/104
6ES7 298-.....	3/6, 3/7, 3/11, 3/15, 3/19, 3/22, 3/42, 3/45, 3/49, 3/52, 3/57, 3/60, 3/74, 3/76, 3/79, 3/81, 3/84, 3/87, 3/89, 3/92, 3/94, 3/103, 3/106, 3/107

6ES7 3

6ES7 307-.....	5/90, 5/93, 5/95, 5/142, 5/145, 5/149, 5/152, 5/243
6ES7 312-.....	5/12, 5/26
6ES7 313-.....	5/26
6ES7 314-.....	5/12, 5/26
6ES7 315-.....	5/12, 5/38, 5/47
6ES7 317-.....	5/12, 5/38, 5/47
6ES7 318-.....	5/12, 5/38
6ES7 321-.....	5/54, 5/101
6ES7 322-.....	5/60, 5/103
6ES7 323-.....	5/64
6ES7 326-.....	5/90, 5/93
6ES7 327-.....	5/64
6ES7 328-.....	5/54, 5/60, 5/64, 5/76, 5/79, 5/82, 5/90, 5/93, 5/95, 5/101, 5/103, 5/106, 5/108, 5/138, 5/223
6ES7 331-.....	5/76, 5/106, 9/202, 9/206
6ES7 332-.....	5/79, 5/108, 9/204, 9/208
6ES7 334-.....	5/82
6ES7 336-.....	5/95
6ES7 338-.....	5/138
6ES7 340-.....	5/160
6ES7 341-.....	5/162

6ES7 350-.....	5/110, 5/112
6ES7 351-.....	5/114
6ES7 352-.....	5/116, 5/120
6ES7 353-.....	5/122
6ES7 354-.....	5/124
6ES7 355-.....	5/131, 5/136
6ES7 357-.....	5/126
6ES7 360-.....	5/233
6ES7 361-.....	5/233
6ES7 365-.....	5/233
6ES7 368-.....	5/233
6ES7 370-.....	5/158, 5/168, 5/172
6ES7 374-.....	5/157
6ES7 390-.....	4/45, 5/54, 5/60, 5/64, 5/76, 5/79, 5/82, 5/110, 5/112, 5/114, 5/116, 5/122, 5/124, 5/131, 5/136, 5/142, 5/145, 5/148, 5/152, 5/157, 5/158, 5/230, 5/243, 5/247, 6/153, 9/194, 9/196, 9/202, 9/204, 9/206, 9/208, 9/221, 9/229, 9/234, 9/244, 9/246, 9/249
6ES7 391-.....	5/12, 5/26, 5/38, 5/48
6ES7 392-.....	5/26, 5/27, 5/47, 5/48, 5/54, 5/60, 5/64, 5/76, 5/79, 5/82, 5/90, 5/93, 5/95, 5/101, 5/103, 5/106, 5/108, 5/110, 5/112, 5/114, 5/116, 5/120, 5/122, 5/124, 5/126, 5/131, 5/136, 5/138, 5/142, 5/145, 5/148, 5/152, 5/157, 5/158, 5/166, 5/213, 5/223, 5/248, 9/202, 9/204, 9/206, 9/208, 9/216
6ES7 393-.....	5/90, 5/93, 5/95, 5/101, 5/103, 5/106, 5/108, 9/202, 9/204, 9/206, 9/208
6ES7 398-.....	5/12, 5/26, 5/38, 5/47, 5/54, 5/60, 5/64, 5/76, 5/79, 5/82, 5/90, 5/93, 5/95, 5/138, 5/233

6ES7 4

6ES7 400-.....	6/39, 6/132
6ES7 401-.....	6/132
6ES7 403-.....	6/132
6ES7 405-.....	6/147
6ES7 407-.....	6/147
6ES7 408-.....	6/133, 6/150
6ES7 412-.....	6/7, 6/39
6ES7 414-.....	6/11, 6/28, 6/39
6ES7 416-.....	6/16, 6/33, 6/39
6ES7 417-.....	6/20, 6/39
6ES7 421-.....	6/58
6ES7 422-.....	6/61
6ES7 431-.....	6/72, 6/128
6ES7 432-.....	6/74
6ES7 440-.....	6/103
6ES7 441-.....	6/105

6ES7 450-.....	6/78
6ES7 451-.....	6/80
6ES7 452-.....	6/82
6ES7 453-.....	6/84
6ES7 455-.....	6/89
6ES7 460-.....	6/135, 6/137, 6/139
6ES7 461-.....	6/136, 6/138, 6/140
6ES7 463-.....	6/141
6ES7 468-.....	6/135, 6/136, 6/137, 6/138, 6/139, 6/140
6ES7 490-.....	6/128, 6/132, 6/147, 6/150
6ES7 492-.....	6/58, 6/61, 6/72, 6/74, 6/78, 6/80, 6/82, 6/84, 6/89, 6/128, 6/149, 6/150

6ES7 5

6ES7 505-.....	4/8, 4/49, 9/188
6ES7 507-.....	4/8, 4/49, 9/188
6ES7 511-.....	4/8, 4/9
6ES7 513-.....	4/8
6ES7 516-.....	4/8
6ES7 521-.....	4/12
6ES7 522-.....	4/16
6ES7 528-.....	4/12, 4/16, 4/22, 4/25, 4/30, 4/54, 9/188
6ES7 531-.....	4/22
6ES7 532-.....	4/25
6ES7 540-.....	4/33
6ES7 541-.....	4/33
6ES7 550-.....	4/30
6ES7 590-.....	4/8, 4/12, 4/16, 4/22, 4/25, 4/30, 4/49, 4/53, 4/54, 9/188
6ES7 591-.....	4/9
6ES7 592-.....	4/12, 4/16, 4/22, 4/25, 4/30, 4/39, 4/53

6ES7 6

6ES7 647-.....	7/18, 7/19
6ES7 648-.....	7/19, 7/22, 12/5
6ES7 658-.....	11/20, 11/54, 11/55, 11/56, 11/57, 11/58
6ES7 671-.....	7/31, 8/7, 8/13
6ES7 675-.....	7/20, 7/21, 7/22
6ES7 677-.....	7/9, 7/10

6ES7 7

6ES7 716-.....	12/4, 12/5
6ES7 790-.....	12/5
6ES7 791-.....	12/5
6ES7 792-.....	9/43, 9/46, 9/52, 9/55, 11/9, 11/11, 12/6
6ES7 798-.....	12/5

6ES7 8

6ES7 803-.....	11/28
6ES7 806-.....	8/14
6ES7 807-.....	11/33
6ES7 810-.....	11/6, 11/9, 11/11, 11/13, 12/5
6ES7 811-.....	11/15, 11/17

6ES7 820-.....	5/184, 6/119, 11/27, 12/18
6ES7 822-.....	3/7, 3/11, 3/15, 3/19, 3/22, 4/9, 4/35, 4/38, 11/5, 11/6
6ES7 830-.....	11/36, 11/39
6ES7 833-.....	5/38, 5/90, 5/93, 5/95, 6/28, 6/33, 6/40, 9/52, 9/55, 9/136, 9/139, 9/141, 9/236, 9/237, 9/239, 9/240, 9/242, 9/243, 9/270, 9/334, 11/7, 11/21, 11/23, 11/24
6ES7 840-.....	11/29, 11/52
6ES7 841-.....	11/18
6ES7 842-.....	11/32
6ES7 852-.....	6/97, 11/48
6ES7 860-.....	11/34, 11/36, 11/39, 11/40
6ES7 862-.....	11/25
6ES7 864-.....	5/47, 11/45, 11/47
6ES7 870-.....	5/162, 5/164, 6/105, 6/107

6ES7 9

6ES7 900-.....	12/5
6ES7 901-.....	5/12, 5/26, 5/38, 5/47, 6/7, 6/11, 6/16, 6/20, 6/28, 6/33, 6/40, 9/337, 11/9, 11/11, 11/13, 11/32, 12/5
6ES7 902-.....	4/33, 5/26, 5/160, 5/162, 6/103, 6/105
6ES7 910-.....	5/12
6ES7 912-.....	5/12, 5/26, 5/38, 5/47, 5/110, 5/112, 5/114, 5/116, 5/122, 5/124, 5/131, 5/136, 6/7, 6/11, 6/16, 6/20, 6/28, 6/33, 6/40
6ES7 921-.....	4/45, 5/229, 5/230
6ES7 922-.....	4/47, 5/232, 6/130
6ES7 923-.....	4/45, 5/230
6ES7 924-.....	4/45, 4/46, 5/230, 5/231
6ES7 928-.....	4/45, 4/46, 5/230, 5/231
6ES7 952-.....	6/7, 6/11, 6/16, 6/20, 6/28, 6/33, 6/39
6ES7 953-.....	5/12, 5/26, 5/38, 5/47, 5/120, 6/92, 9/43, 9/46, 9/52, 9/55, 9/66, 9/196, 9/263, 9/265, 9/270
6ES7 954-.....	3/6, 3/10, 3/14, 3/18, 3/21, 4/8
6ES7 960-.....	6/41
6ES7 963-.....	6/105
6ES7 964-.....	6/11, 6/16, 6/20, 6/28, 6/33, 6/54
6ES7 971-.....	5/126, 5/198, 5/203, 6/147, 10/2
6ES7 972-.....	3/109, 3/112, 4/8, 5/12, 5/27, 5/39, 5/48, 5/168, 5/172, 6/7, 6/11, 6/16, 6/20, 6/28, 6/29, 6/34, 6/40, 6/92, 6/109, 6/111, 6/153, 9/43, 9/47, 9/63, 9/221, 9/229, 9/234, 9/236, 9/239, 9/242, 9/244, 9/246, 9/249, 9/335, 9/337, 9/346, 9/347, 11/32
6ES7 973-.....	5/60
6ES7 974-.....	5/76, 5/110, 6/72, 6/150
6ES7 991-.....	9/257, 11/50
6ES7 998-.....	5/12, 5/26, 5/38, 5/47, 5/54, 5/60, 5/64, 5/76, 5/79, 5/82, 5/90, 5/93, 5/95, 5/101, 5/103, 5/106, 5/108, 5/138, 5/164, 5/233, 6/7, 6/11, 6/16, 6/20, 6/28, 6/33, 6/40, 6/58, 6/61, 6/72, 6/74, 6/97, 6/107, 6/128, 6/153, 9/7, 9/62, 9/66, 9/136, 9/139, 9/141, 9/194, 9/196, 9/204, 9/208, 9/257, 9/260, 9/263, 9/334, 9/337, 11/9, 11/11, 11/15, 11/17, 11/18, 11/20, 11/25, 11/28, 11/29, 11/32, 11/33, 11/36, 11/39, 11/40, 11/42, 11/44, 11/48, 15/5

6F

6FC5 263-.....	5/122, 5/124, 5/126
6FX2 001-.....	9/116, 9/120
6FX2 002-.....	5/140, 6/84
6FX5 002-.....	5/110, 5/112, 5/114, 5/116, 5/120, 5/124, 5/126, 5/138, 6/80, 6/82, 6/84, 9/109, 9/116, 9/120
6FX5 012-.....	5/114, 5/116, 5/124, 5/126, 6/80, 6/84
6FX5 042-.....	5/114, 5/116, 5/124, 5/126, 6/80, 6/84
6FX8 002-.....	5/122, 5/124
6FX8 012-.....	5/122, 5/124
6FX8 042-.....	5/122, 5/124

6GK1

6GK1 160-.....	7/17, 7/22, 8/7, 8/13
6GK1 161-.....	8/7, 8/13, 12/10
6GK1 162-.....	12/10
6GK1 182-.....	9/344, 9/345
6GK1 184-.....	9/344, 9/345
6GK1 500-.....	3/109, 3/112, 4/35, 5/12, 5/27, 5/39, 5/48, 5/168, 5/172, 6/7, 6/11, 6/16, 6/20, 6/28, 6/34, 6/40, 6/109, 6/111, 7/14
6GK1 551-.....	11/9, 11/12, 11/13
6GK1 560-.....	7/13, 7/22, 8/7, 8/13
6GK1 561-.....	7/13, 8/7, 8/13, 11/9, 11/12, 11/13
6GK1 562-.....	8/7, 8/13
6GK1 571-.....	5/12, 5/27, 5/38, 5/48, 11/9, 11/12, 11/13
6GK1 588-.....	9/339
6GK1 704-.....	5/175, 5/178, 5/183, 5/184, 5/187, 6/113, 6/114, 6/118, 11/9, 11/12, 12/8, 12/12, 12/14
6GK1 706-.....	12/12, 12/16, 12/18, 12/19
6GK1 713-.....	7/13, 7/14
6GK1 716-.....	12/10
6GK1 900-.....	5/178, 9/65, 9/260
6GK1 901-.....	2/25, 3/114, 4/9, 4/37, 4/38, 5/13, 5/27, 5/39, 5/170, 5/175, 5/178, 5/184, 5/187, 5/189, 5/192, 5/195, 5/198, 5/200, 5/203, 5/206, 5/211, 6/12, 6/17, 6/29, 6/34, 6/114, 6/118, 6/119, 6/124, 9/7, 9/37, 9/46, 9/55, 9/63, 9/65, 9/66, 9/188, 9/196, 9/260, 9/263, 9/265, 9/266, 9/271, 9/323, 9/326
6GK1 905-.....	3/109, 3/112, 4/8, 4/35, 5/170, 7/14, 9/256, 9/259, 9/262, 9/266, 9/267, 9/271, 9/272, 9/288, 9/333, 9/337
6GK1 907-.....	9/260, 9/288, 9/289, 9/323, 9/326
6GK1 953-.....	9/344, 9/345

Appendix

Order No. index

6GK5

6GK5 200-	9/66
6GK5 201-	9/66
6GK5 202-	9/66
6GK5 204-	4/37, 5/13, 5/27, 5/39, 5/178, 6/12, 6/17, 6/29, 6/34, 6/114, 6/119, 7/17
6GK5 208-	9/265, 9/270
6GK5 308-	4/37, 5/184, 5/187, 6/119
6GK5 612-	5/206, 5/211, 6/124
6GK5 623-	5/206, 5/211, 6/124
6GK5 792-	9/262
6GK5 793-	9/262
6GK5 795-	9/262
6GK5 873-	5/211, 6/124
6GK5 875-	5/211, 6/124

6GK7

6GK7 177-	2/25
6GK7 242-	3/109, 3/116
6GK7 243-	3/112
6GK7 277-	3/114
6GK7 342-	5/168, 5/170
6GK7 343-	5/166, 5/172, 5/175, 5/178, 5/183, 5/187, 5/211, 6/124
6GK7 377-	5/13, 5/27, 5/39, 5/175, 5/178, 5/184, 5/189
6GK7 443-	5/211, 6/109, 6/111, 6/113, 6/118, 6/124

6GT

6GT2 002-	5/213, 9/216, 9/293
6GT2 080-	5/213, 9/216, 9/293
6GT2 091-	5/213, 9/216, 9/293
6GT2 491-	5/213, 9/216
6GT2 691-	9/293
6GT2 891-	5/213, 9/216, 9/293

6NH

6NH7 701-	5/192, 5/195, 5/198, 5/200, 5/203
6NH7 800-	5/192, 5/195, 5/198
6NH7 803-	5/200, 5/203
6NH7 997-	5/192, 5/195, 5/198, 5/200, 5/203
6NH9 741-	5/206
6NH9 860-	3/116, 5/206, 5/211, 6/124
6NH9 870-	3/116, 5/206
6NH9 910-	3/116

6S

6SL3 555-	9/183, 9/310
6SW1 700-	11/49

6X

6XV1 801-	9/323, 9/326
6XV1 822-	9/256, 9/259, 9/262, 9/266, 9/271, 9/288, 9/333
6XV1 830-	3/109, 3/112, 4/8, 5/12, 5/27, 5/39, 5/48, 6/7, 6/11, 6/16, 6/20, 6/29, 6/34, 6/40, 6/92, 7/14, 9/43, 9/47, 9/249, 9/255, 9/256, 9/257, 9/259, 9/262, 9/266, 9/267, 9/271, 9/272, 9/288, 9/333, 9/337
6XV1 831-	4/8
6XV1 840-	4/9, 4/37, 5/13, 5/27, 5/39, 5/175, 5/178, 5/184, 5/189, 5/192, 5/195, 5/198, 5/200, 5/203, 6/12, 6/17, 6/29, 6/34, 6/114, 6/118, 9/46, 9/55, 9/65, 9/188, 9/196, 9/259, 9/266, 9/271
6XV1 860-	9/256, 9/257, 9/288
6XV1 870-	2/25, 3/114, 4/37, 5/184, 5/187, 5/206, 5/211, 6/118, 6/124, 7/17, 9/259, 9/262, 9/263, 9/266, 9/271, 9/272, 9/323, 9/326
6XV1 873-	5/13, 5/27, 5/39, 6/12, 6/17, 6/29, 6/34
6XV1 875-	9/262
6XV1 878-	4/37, 6/118
6XX3 070	6/128
6XX3 071	6/128

7M

7ME4120-	5/152
7MH4 407-	9/125
7MH4 607-	9/125
7MH4 702-	9/125, 9/127
7MH4 710-	9/125, 9/127
7MH4 910-	9/125
7MH4 920-	9/127
7MH4407-	5/143, 5/146, 5/149
7MH4607-	5/142
7MH4683-	5/142
7MH4702-	5/143, 5/145, 5/146, 5/148, 5/149
7MH4710-	5/143, 5/146, 5/149
7MH4900-	5/145, 5/148, 5/149
7MH4950-	5/142
8WA2	9/105, 9/125, 9/127, 9/129, 9/132, 9/143
8WA8	9/129, 9/132, 9/143, 9/221, 9/229, 9/234, 9/236, 9/239, 9/242, 9/244, 9/246

A

A5E...	5/152
--------------	-------

C

C71000-	5/143, 5/146, 5/149, 9/125
---------------	----------------------------

F

FDK...	5/152
--------------	-------

M

MH4900-	5/145
---------------	-------

Z

ZNX.....	9/184, 9/185
----------	--------------

Appendix

Catalog improvement suggestions

Fax form

To

Siemens AG
 I IA CC PRI 1
 Mr. Fregien
 Gleiwitzer Str. 555
 90475 Nürnberg

Fax: +49 (911) 895-154830

E-mail: dirk.fregien@siemens.com

Your address

 Name

 Job

 Company/Department

 Street/No.

 Postal code/City

 Tel. No./Fax

 E-mail address

Your opinion is important to us!

Our catalog should be an important and frequently used document. For this reason we are continuously endeavoring to improve it.

A small request on our part to you:
 Please take time to fill in the following form and fax it to us.
 Thank You!

We invite you to grade our catalog on a point system from 1 (= good) to 6 (= poor):

Do the contents of the catalog live up to your expectations?

Do the technical details meet your expectations?

Is the information easy to find?

How would you assess the graphics and tables?

Can the texts be readily understood?

Did you find any printing errors?

Appendix

Notes

Appendix

Conditions of sale and delivery

1. General Provisions

By using this catalog you can acquire hardware and software products described therein from Siemens AG subject to the following Terms and Conditions of Sale and Delivery (hereinafter referred to as "T&C"). Please note that the scope, the quality and the conditions for supplies and services, including software products, by any Siemens entity having a registered office outside Germany, shall be subject exclusively to the General Terms and Conditions of the respective Siemens entity. The following T&C apply exclusively for orders placed with Siemens Aktiengesellschaft, Germany.

1.1 For customers with a seat or registered office in Germany

For customers with a seat or registered office in Germany, the following applies subordinate to the T&C:

- the "General Terms of Payment"¹⁾ and,
- for software products, the "General License Conditions for Software Products for Automation and Drives for Customers with a Seat or Registered Office in Germany"¹⁾ and,
- for other supplies and services, the "General Conditions for the Supply of Products and Services of the Electrical and Electronics Industry"¹⁾.

1.2 For customers with a seat or registered office outside Germany

For customers with a seat or registered office outside Germany, the following applies subordinate to the T&C:

- the "General Terms of Payment"¹⁾ and,
- for software products, the "General License Conditions for Software Products for Automation and Drives for Customers with a Seat or Registered Office outside of Germany"¹⁾ and
- for other supplies and/or services, the "General Conditions for Supplies of Siemens Industry for Customers with a Seat or Registered Office outside of Germany"¹⁾.

2. Prices

The prices are in € (Euro) ex point of delivery, exclusive of packaging.

The sales tax (value added tax) is not included in the prices. It shall be charged separately at the respective rate according to the applicable statutory legal regulations.

Prices are subject to change without prior notice. We will charge the prices valid at the time of delivery.

To compensate for variations in the price of raw materials (e.g. silver, copper, aluminum, lead, gold, dysprosium and neodym), surcharges are calculated on a daily basis using the so-called metal factor for products containing these raw materials. A surcharge for the respective raw material is calculated as a supplement to the price of a product if the basic official price of the raw material in question is exceeded.

The metal factor of a product indicates the basic official price (for those raw materials concerned) as of which the surcharges on the price of the product are applied, and with what method of calculation.

An exact explanation of the metal factor can be downloaded at:

www.siemens.com/automation/salesmaterial-as/catalog/en/terms_of_trade_en.pdf

To calculate the surcharge (except in the cases of dysprosium and neodym), the official price from the day prior to that on which the order was received or the release order was effected is used.

To calculate the surcharge applicable to dysprosium and neodym ("rare earths"), the corresponding three-month basic average price in the quarter prior to that in which the order was received or the release order was effected is used with a one-month buffer (details on the calculation can be found in the explanation of the metal factor).

3. Additional Terms and Conditions

The dimensions are in mm. In Germany, according to the German law on units in measuring technology, data in inches apply only to devices for export.

Illustrations are not binding.

Insofar as there are no remarks on the individual pages of this catalog - especially with regard to data, dimensions and weights given - these are subject to change without prior notice.

4. Export regulations

We shall not be obligated to fulfill any agreement if such fulfillment is prevented by any impediments arising out of national or international foreign trade or customs requirements or any embargoes and/or other sanctions.

Export of goods listed in this catalog may be subject to licensing requirements. We will indicate in the delivery details whether licenses are required under German, European and US export lists. Goods labeled with "AL" not equal to "N" are subject to European or German export authorization when being exported out of the EU. Goods labeled with "ECCN" not equal to "N" are subject to US re-export authorization.

The export indications can be viewed in advance in the description of the respective goods on the Industry Mall, our online catalog system. Only the export labels "AL" and "ECCN" indicated on order confirmations, delivery notes and invoices are authoritative.

Even without a label, or with label "AL:N" or "ECCN:N", authorization may be required i .a. due to the final disposition and intended use of goods.

If you transfer goods (hardware and/or software and/or technology as well as corresponding documentation, regardless of the mode of provision) delivered by us or works and services (including all kinds of technical support) performed by us to a third party worldwide, you must comply with all applicable national and international (re-)export control regulations.

If required for the purpose of conducting export control checks, you (upon request by us) shall promptly provide us with all information pertaining to the particular end customer, final disposition and intended use of goods delivered by us respectively works and services provided by us, as well as to any export control restrictions existing in this relation.

The products listed in this catalog may be subject to European/German and/or US export regulations. Any export requiring approval is therefore subject to authorization by the relevant authorities.

Errors excepted and subject to change without prior notice.

1) The text of the Terms and Conditions of Siemens AG can be downloaded at www.siemens.com/automation/salesmaterial-as/catalog/en/terms_of_trade_en.pdf

Industry Automation, Drive Technologies and Low-Voltage Power Distribution

Further information can be obtained from our branch offices listed at www.siemens.com/automation/partner

System Solutions Interactive Catalog on DVD	<i>Catalog</i>		
Products for Automation and Drives	CA 01		
Building Control			
GAMMA Building Control	ET G1		
Drive Systems			
<u>Variable-Speed Drives</u>			
SINAMICS G130 Drive Converter Chassis Units	D 11		
SINAMICS G150 Drive Converter Cabinet Units			
SINAMICS GM150, SINAMICS SM150 Medium-Voltage Converters	D 12		
ROBICON Perfect Harmony Medium-Voltage Air-Cooled Drives Germany Edition	D 15.1		
<i>Digital: SINAMICS G180 Converters – Compact Units, Cabinet Systems, Cabinet Units Air-Cooled and Liquid-Cooled</i>	D 18.1		
SINAMICS S120 Chassis Format Units and Cabinet Modules	D 21.3		
SINAMICS S150 Converter Cabinet Units			
SINAMICS DCM Converter Units	D 23.1		
SINAMICS and Motors for Single-Axis Drives	D 31		
<u>Three-Phase Induction Motors SIMOTICS HV, SIMOTICS TN</u>	D 84.1		
• Series H-compact			
• Series H-compact PLUS			
Asynchronous Motors Standardline	D 86.1		
Synchronous Motors with Permanent-Magnet Technology, HT-direct	D 86.2		
DC Motors	DA 12		
SIMOREG DC MASTER 6RA70 Digital Chassis Converters	DA 21.1		
SIMOREG K 6RA22 Analog Chassis Converters	DA 21.2		
<i>Digital: SIMOREG DC MASTER 6RM70 Digital Converter Cabinet Units</i>	DA 22		
SIMOVERT PM Modular Converter Systems	DA 45		
SIEMOSYN Motors	DA 48		
MICROMASTER 420/430/440 Inverters	DA 51.2		
MICROMASTER 411/COMBIMASTER 411	DA 51.3		
SIMOVERT MASTERDRIVES Vector Control	DA 65.10		
SIMOVERT MASTERDRIVES Motion Control	DA 65.11		
Synchronous and asynchronous servomotors for SIMOVERT MASTERDRIVES	DA 65.3		
SIMODRIVE 611 universal and POSMO	DA 65.4		
<i>Note: Additional catalogs on SIMODRIVE or SINAMICS drive systems and SIMOTICS motors with SINUMERIK and SIMOTION can be found under Motion Control</i>			
<u>Low-Voltage Three-Phase-Motors</u>			
SIMOTICS Low-Voltage Motors	D 81.1		
MOTOX Geared Motors	D 87.1		
SIMOGEAR Geared Motors	MD 50.1		
<u>Mechanical Driving Machines</u>			
FLENDER Standard Couplings	MD 10.1		
FLENDER High Performance Couplings	MD 10.2		
FLENDER SIG Standard industrial gear unit	MD 30.1		
FLENDER SIP Standard industrial planetary gear units	MD 31.1		
Process Instrumentation and Analytics			
Field Instruments for Process Automation	FI 01		
<i>Digital: SIPART Controllers and Software</i>	MP 31		
Products for Weighing Technology	WT 10		
<i>Digital: Process Analytical Instruments</i>	PA 01		
<i>Digital: Process Analytics, Components for the System Integration</i>	PA 11		
Low-Voltage Power Distribution and Electrical Installation Technology	<i>Catalog</i>		
SENTRON Protection, Switching, Measuring and Monitoring Devices	LV 10.1		
SIVACON · ALPHA Switchboards and Distribution Systems	LV 10.2		
Standards-Compliant Components for Photovoltaic Plants	LV 11		
3WT Air Circuit Breakers up to 4000 A	LV 35		
3VT Molded Case Circuit Breakers up to 1600 A	LV 36		
<i>Digital: SIVACON System Cubicles, System Lighting and System Air-Conditioning</i>	LV 50		
<i>Digital: ALPHA Distribution Systems</i>	LV 51		
ALPHA FIX Terminal Blocks	LV 52		
SIVACON S4 Power Distribution Boards	LV 56		
SIVACON 8PS Busbar Trunking Systems	LV 70		
Motion Control			
SINUMERIK & SIMODRIVE Automation Systems for Machine Tools	NC 60		
SINUMERIK & SINAMICS Equipment for Machine Tools	NC 61		
SINUMERIK 840D sl Type 1B Equipment for Machine Tools	NC 62		
SINUMERIK 808D, SINAMICS V60 and G120, SIMOTICS 1FL5 and 1LE1	NC 81.1		
SINUMERIK 828D BASIC T/BASIC M, SINAMICS S120 Combi, 1FK7 and 1PH8 motors	NC 82		
SIMOTION, SINAMICS S120 & SIMOTICS Equipment for Production Machines	PM 21		
Drive and Control Components for Cranes	CR 1		
Power Supply and System Cabling			
Power supply SITOP	KT 10.1		
Safety Integrated			
Safety Technology for Factory Automation	SI 10		
SIMATIC HMI/PC-based Automation			
Human Machine Interface Systems/ PC-based Automation	ST 80/ ST PC		
SIMATIC Ident			
Industrial Identification Systems	ID 10		
SIMATIC Industrial Automation Systems			
Products for Totally Integrated Automation	ST 70		
SIMATIC PCS 7 Process Control System	ST PCS 7		
Add-ons for the SIMATIC PCS 7 Process Control System	ST PCS 7.1		
<i>Digital: Migration solutions with the SIMATIC PCS 7 Process Control System</i>	ST PCS 7.2		
SIMATIC NET			
Industrial Communication	IK PI		
SINVERT Photovoltaics			
Inverters and Components for Photovoltaic Installations	RE 10		
SIRIUS Industrial Controls			
SIRIUS Industrial Controls	IC 10		

Information and Download Center

PDF versions of the catalogs are available on the Internet at:
www.siemens.com/industry/infocenterPlease note the section "Downloading catalogs" on page
"Online services" in the appendix of this catalog.*Digital: These catalogs are only available as a PDF
and/or as an e-book.*

Siemens AG
Industry Sector
Industrial Automation Systems
Postfach 48 48
90026 NÜRNBERG
GERMANY

Subject to change without prior notice
Order No. E86060-K4670-A101-B4-7600
MQ.R1.AS.0000.02.3.01 / Dispo 07900
KG 0513 12. KR D 1208 En / IWI TSTJ
Printed in Germany
© Siemens AG 2013

The information provided in this catalog contains descriptions or characteristics of performance which in case of actual use do not always apply as described or which may change as a result of further development of the products. An obligation to provide the respective characteristics shall only exist if expressly agreed in the terms of contract. Availability and technical specifications are subject to change without notice.

All product designations may be trademarks or product names of Siemens AG or supplier companies whose use by third parties for their own purposes could violate the rights of the owners.